

isc Silicon NPN Power Transistors

KSD5018

DESCRIPTION

- High Breakdown Voltage-
: $V_{(BR)CEO} = 275V(\text{Min})$
- Built-in Resistor Between Base and Emitter
- Wide Area of Safe Operation

APPLICATIONS

- Designed for motor drive and general purpose applications

ABSOLUTE MAXIMUM RATINGS($T_a=25^\circ\text{C}$)

SYMBOL	PARAMETER	VALUE	UNIT
V_{CBO}	Collector-Base Voltage	600	V
V_{CEO}	Collector-Emitter Voltage	275	V
V_{EBO}	Emitter-Base Voltage	10	V
I_C	Collector Current-Continuous	4	A
I_{CM}	Collector Current-Peak	6	A
I_B	Base Current-Continuous	0.5	A
P_C	Collector Power Dissipation @ $T_C=25^\circ\text{C}$	40	W
T_J	Junction Temperature	150	$^\circ\text{C}$
T_{stg}	Storage Temperature Range	-55~150	$^\circ\text{C}$

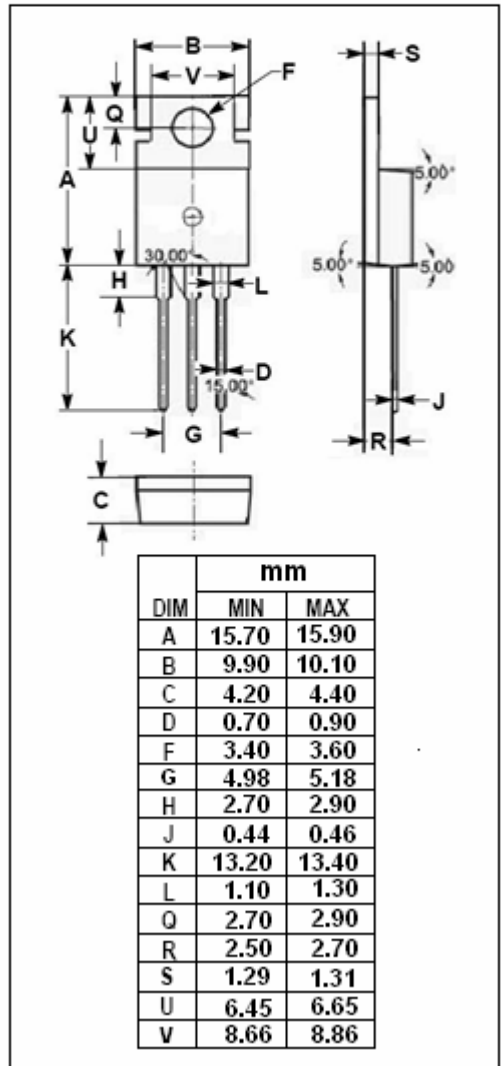
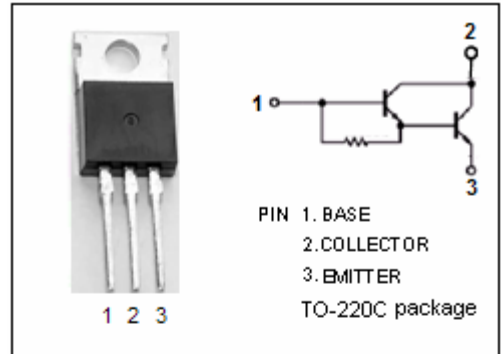

isc Silicon NPN Power Transistors**KSD5018****ELECTRICAL CHARACTERISTICS** $T_C=25^{\circ}\text{C}$ unless otherwise specified

SYMBOL	PARAMETER	CONDITIONS	MIN	TYP.	MAX	UNIT
V_{CER}	Collector-Emitter Voltage	$I_C=1\text{mA}$; $R_{\text{BE}}=330\ \Omega$	600			V
$V_{\text{CEO(SUS)}}$	Collector-Emitter Sustaining Voltage	$I_C=1.5\text{A}$; $I_{\text{B1}}=0.05\text{A}$; Clamped	275			V
$V_{\text{CE(sat)-1}}$	Collector-Emitter Saturation Voltage	$I_C=2\text{A}$; $I_B=5\text{mA}$			1.5	V
$V_{\text{CE(sat)-2}}$	Collector-Emitter Saturation Voltage	$I_C=3\text{A}$; $I_B=20\text{mA}$			1.5	V
$V_{\text{BE(sat)}}$	Base-Emitter Saturation Voltage	$I_C=2\text{A}$; $I_B=5\text{mA}$			2.0	V
I_{CES}	Collector Cutoff Current	$V_{\text{CE}}=500\text{V}$			1	mA
I_{EBO}	Emitter Cutoff Current	$V_{\text{EB}}=10\text{V}$; $I_C=0$			1	mA
$h_{\text{FE-1}}$	DC Current Gain	$I_C=2\text{A}$; $V_{\text{CE}}=2\text{V}$	1000			
$h_{\text{FE-2}}$	DC Current Gain	$I_C=4\text{A}$; $V_{\text{CE}}=2\text{V}$	200			