

## 3.0MHz High Efficiency Low I<sub>Q</sub> Synchronous Boost

### Features

- Wide Input Voltage Range: 2.5V to 5.5V
- Output Voltage 5.0V
- I<sub>OUT</sub> up to 1.0 A at V<sub>OUT</sub> = 5.0 V, V<sub>IN</sub> ≥ 3.0 V
- 3MHz PWM Switching Frequency
- High Efficiency and Low Quiescent Current
  - ▶ Over 95% Efficiency
  - ▶ 1μA Shutdown Current
  - ▶ 35μA Quiescent Current in Pass Through
  - ▶ 55μA Quiescent Current in PFM Operation
- ±2% DC Voltage Accuracy in PWM mode
- Undervoltage Lockout (UVLO)
- Short Circuit Protection
- Hiccup Current Limit
- Over Temperature Protection
- Selectable Pass Through Mode or True Load Disconnect During Shutdown
- Output Capacitor Pre-Charge and Soft-Start
- Pb-free 9-Bump, WLCSP 1.38mm x 1.38mm
- RoHS and Green Compliant
- -40°C to 85°C Operating Temperature Range

### Brief Description

The KTC2110 features a high-efficiency, micropower synchronous boost for Lithium-Ion/Polymer battery applications. It offers true output disconnect to achieve a shutdown quiescent current of less than 1.0μA, extending battery life.

High efficiency over a wide output current range is achieved by selecting PWM/PFM mode automatically depending on the output load conditions.

A Pass Through mode allows to transfer the input power directly to output (not boosting) with over current protection.

The constant on-time design does not require any external compensation components, simplifying the design and providing ultra-fast transient response.

The inrush current-limiting feature minimizes the voltage droop on the battery supply when the device is turned on.

The KTC2110 is packaged in advanced, RoHS and Green compliant, 1.38mm x 1.38mm, 9-balls Wafer-Level Chip-Scale Package (WLCSP).

### Applications

- Smartphones and Tablets
- Mobile Internet Devices
- USB OTG
- Wearables
- Portable Devices

### Typical Application

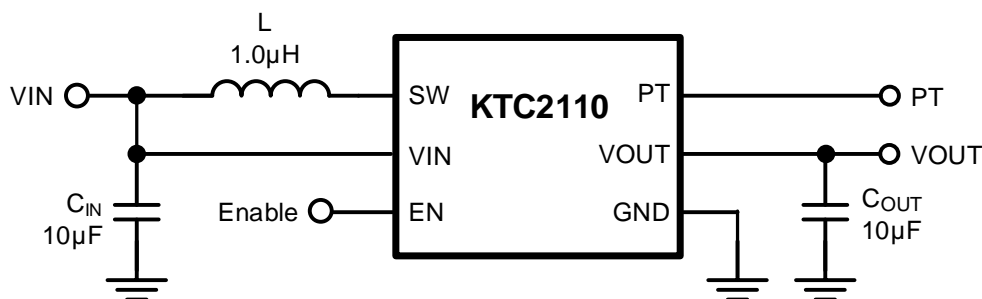

## Pin Descriptions

Pin #	Name	Function
A1, A2	OUT	Boost converter output
A3	IN	Power supply input
B1, B2	SW	Boost switching node, connect to inductor
B3	EN	Active HIGH enable
C1, C2	GND	Ground
C3	PT	Active HIGH enable pass through mode

### WLCSP-9

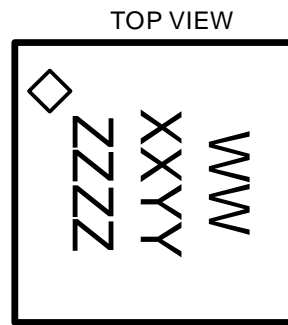
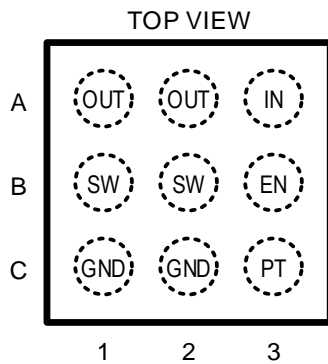

Top View

9-Bump 1.38mm x 1.38mm x 0.620mm  
WLCSP Package

Top Mark

WW = Device ID Code  
XX = Date Code, YY = Assembly Code  
ZZZZ = Serial Number

## Absolute Maximum Ratings<sup>1</sup>

(T<sub>A</sub> = 25°C unless otherwise noted)

Symbol	Description	Value	Units
IN	Voltage on IN pin	-0.3 to 6	V
OUT	OUT to GND	-0.3 to 6	V
SW	SW to GND DC	-0.3 to 7	V
	SW to GND AC Transient: 10 ns, 3 MHz	-1.0 to 8.7	V
EN	EN to GND	-0.3 to 6	V
PT	PT to GND	-0.3 to 6	V
Input Current	Continuous average current into SW	3.0	A
	Peak current into SW	3.5	A
T <sub>J</sub>	Junction Operating Temperature Range	-40 to 150	°C
T <sub>S</sub>	Storage Temperature Range	-65 to 150	°C
T <sub>LEAD</sub>	Maximum Soldering Temperature (at leads, 10 sec)	260	°C

## ESD and Latch-Up Ratings

Symbol	Description	Value	Units
V <sub>ESD_HBM</sub>	Human-body model (HBM), per ANSI/ESDA/JEDEC JS-001-2017	±2000	V
V <sub>ESD_CD</sub>	Charged Device Model (CDM), per ANSI/ESDA/JEDEC JS-002-2018	±1000	V
I <sub>LU</sub>	Latch-Up, per JEDEC STANDARD JESD78E	±200	mA

## Thermal Capabilities<sup>2</sup>

Symbol	Description	Value	Units
Θ <sub>JA</sub>	Thermal Resistance – Junction to Ambient	99.3	°C/W
P <sub>D</sub>	Maximum Power Dissipation at 25°C	1.69	W
ΔP <sub>D</sub> /ΔT	Derating Factor Above T <sub>A</sub> = 25°C	-13.5	mW/°C

## Ordering Information

Part Number	V <sub>OUT</sub>	Marking <sup>3</sup>	Operating Temperature	Package
KTC2110ECAA-TR	5.0V	NOXXYYZZZZ	-40°C to +85°C	WLCSP33-9

1. Stresses above those listed in Absolute Maximum Ratings may cause permanent damage to the device. Functional operation at conditions other than the operating conditions specified is not implied. Only one Absolute Maximum rating should be applied at any one time.

2. Junction to Ambient thermal resistance is highly dependent on PCB layout. Values are based on thermal properties of the device when soldered to an EV board.

3. XX = Date Code, YY = Assembly Code, ZZZZ = Serial Number.

**Electrical Characteristics<sup>4</sup>**

Unless otherwise noted, the *Min* and *Max* specs are applied over the full operation temperature range of -40°C to +85°C,  $V_{IN} = 2.5V$  to  $5.5V$ . Typical values are specified at room temperature (25°C) with  $V_{IN} = 3.6V$ ,  $V_{OUT} = 5V$ ,  $EN = HIGH$ ,  $C_{OUT} = 22\mu F$ ,  $L = 1.0\mu H$  and  $T_A = 25^\circ C$ .

Symbol	Description	Conditions	Min	Typ	Max	Units
<b>Supply Specifications</b>						
$V_{IN}$	Input Voltage Range		2.5		5.5	V
$V_{UVLO}$	UVLO Threshold	$V_{IN}$ Rising	2.3	2.4	2.5	V
		$V_{IN}$ Falling		2.3		V
$V_{OVLO}$	OVLO Threshold	$V_{IN}$ Rising	5.5	5.8	6.1	V
		$V_{IN}$ Falling		5.55		V
$I_Q$	Input Quiescent Current	No Load, $V_{EN} = High$		55	80	$\mu A$
$I_{PT}$	Input PT Quiescent Current	Pass Through, $V_{EN} = Low$ , $V_{PT} = High$		35	70	$\mu A$
$I_{SHDN}$	Input Shutdown Current	$V_{EN} = 0V$ ; $V_{IN} = 5.5V$		1	5	$\mu A$
<b>Enable Control (EN)</b>						
$V_{TH-H}$	EN pin logic high voltage		1.2			V
$V_{TH-L}$	EN pin logic low voltage				0.4	V
$I_{EN}$	Enable Low Leakage Current	$V_{EN} = 0V$		0.01	0.1	$\mu A$
	Enable High Leakage Current	$V_{EN} = 1.8V$ , $R_{pd} = 1M\Omega$ internally		2	3	$\mu A$
<b>Pass Through Control (PT)</b>						
$V_{PTTh-H}$	PT pin logic high voltage	$V_{PT}$ Rising, Pass Through Enabled	1.2			V
$V_{PTTh-L}$	PT pin logic low voltage	$V_{PT}$ Falling, Pass Through Off			0.4	V
$I_{PT}$	PT Low Leakage Current	$V_{PT} = 0V$		0.01	0.1	$\mu A$
	PT High Leakage Current	$V_{PT} = 1.8V$ , $R_{pd} = 1M\Omega$ internally		2	3	$\mu A$
<b>Timing</b>						
$T_S$	Soft-Start	EN H to Regulation, $R_L = Open$ , $V_{OUT} = 5.0V$		330		$\mu s$
$T_{RES}$	Fault Restart Timer			22		ms
<b>Boost</b>						
$\Delta V_{OUT}$	Output Voltage Accuracy	$V_{IN} = 2.5V$ to $4.5V$ , $V_{OUT} = 5.0V$	-2		2	%
$\Delta V_{OUT\_LOAD}$	Output Voltage Load Regulation	$V_{IN} = 3.6V$ , $V_{OUT} = 5.0V$ , $I_{OUT} = 50mA$ to $1000mA$		0.5		%
$I_{VIN}$	$V_{IN}$ to $V_{OUT}$ Leakage Current	$V_{OUT} = 0V$ , $EN = PT = 0V$ , $V_{IN} = 4.2V$ ,			1	$\mu A$
$I_{VOUT}$	$V_{OUT}$ Reverse Leakage Current	$V_{OUT} = 5V$ , $V_{IN} = 2.5V$ , $EN = PT = 0V$			3.5	$\mu A$
$R_{DS(ON)P}$	High-Side P-Ch On-Resistance	$I_{SW} = 1A$ , $V_{IN} = 5.0V$		80		m $\Omega$
$R_{DS(ON)N}$	Low-Side N-Ch On-Resistance	$I_{SW} = -1A$ , $V_{IN} = 5.0V$		80		m $\Omega$
$I_{SW\_IN}$	Leakage Current into SW	$V_{IN} = 5V$ , $V_{SW} = 5V$ , $V_{EN} = 0V$		0.1	2	$\mu A$
$I_{SW\_OUT}$	Leakage Current out of SW	$V_{IN} = 5V$ , $V_{SW} = 0V$ , $V_{EN} = 0V$		0.1	2	$\mu A$
$f_{OSC}$	Frequency	$V_{in} = 3.6V$ , $V_o = 5.0V$ , $I_o = 1A$	2.64	3.0	3.36	MHz
$T_{ON}$	Minimum On-Time			40		ns

4. KTC2110 is guaranteed to meet performance specifications over the -40°C to +85°C operating temperature range by design, characterization and correlation with statistical process controls.

## Electrical Characteristics<sup>5</sup>

Unless otherwise noted, the *Min* and *Max* specs are applied over the full operation temperature range of -40°C to +85°C,  $V_{IN} = 2.5V$  to  $5.5V$ . Typical values are specified at room temperature (25°C) with  $V_{IN} = 3.6V$ ,  $V_{OUT} = 5V$ ,  $EN = HIGH$ ,  $C_{OUT} = 22\mu F$ ,  $L = 1.0\mu H$  and  $T_A = 25^\circ C$ .

Symbol	Description	Conditions	Min	Typ	Max	Units
$T_{OFF}$	Minimum OFF Time			90		ns
$I_{LIM}$	Switch Valley Current Limit			2.3		A
	Soft start Valley Current Limit			1.5		A
$I_{PRE}$	Pre-charge Current Limit (Linear Mode)			1.6		A
<b>IC Thermal Protection</b>						
$T_{J\_TH}$	Thermal Shutdown	$T_J$ Rising		150		°C
	Thermal Hysteresis	$T_J$ Falling		20		°C

5. KTC2110 is guaranteed to meet performance specifications over the -40°C to +85°C operating temperature range by design, characterization and correlation with statistical process controls.

Functional Block Diagram

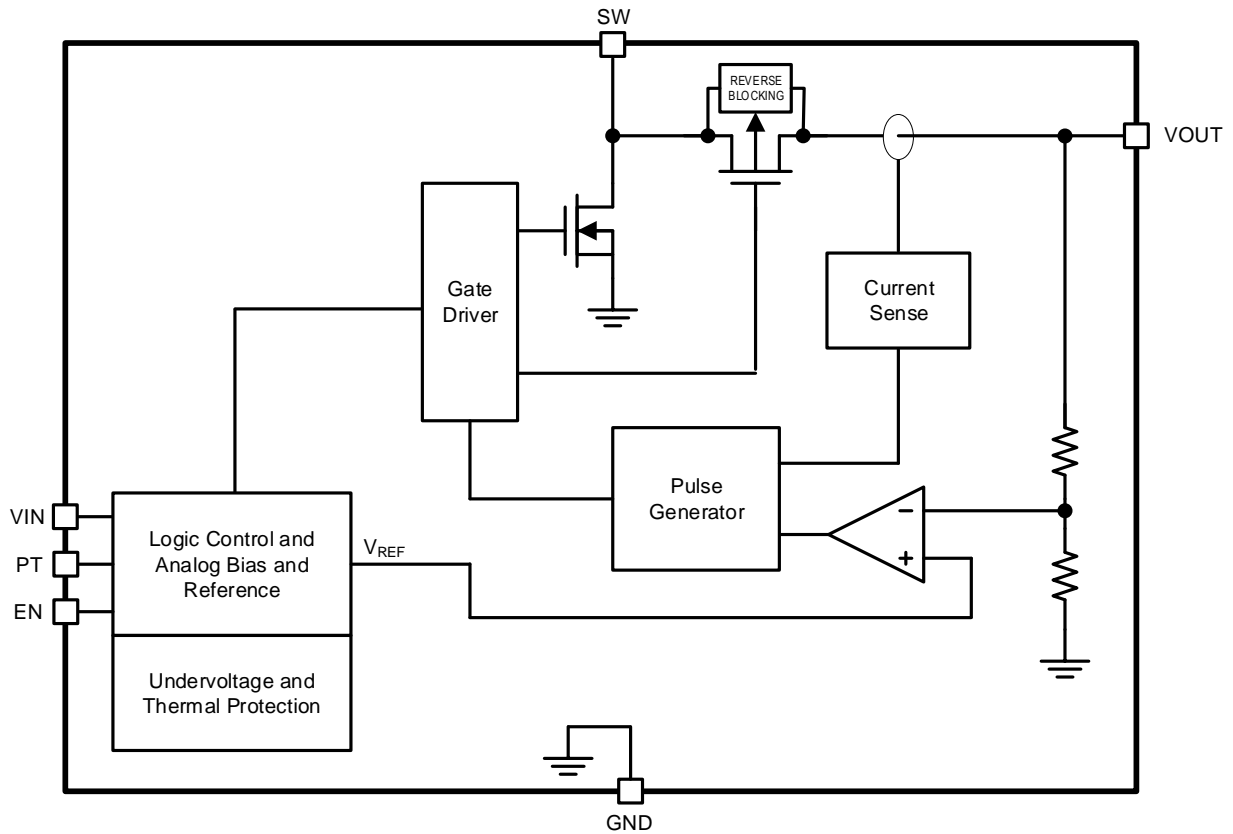

## Typical Characteristics

$V_{IN} = 3.6V$ ,  $V_{OUT} = 5V$ ,  $EN = High$ ,  $PT = Low$ ,  $C_{OUT} = 22\mu F$ ,  $L = 1.0\mu H$  and  $T_A = 25^\circ C$  unless otherwise specified.

### DC Typical Characteristics

Efficiency vs. Output Current

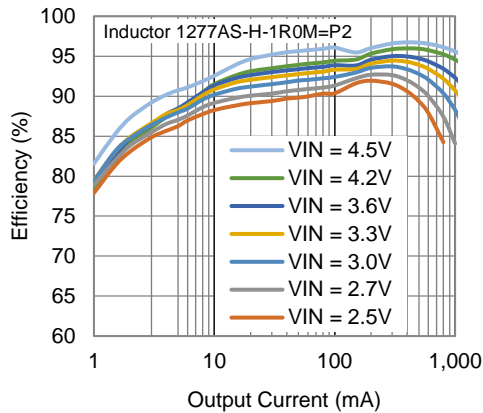

Switching Frequency vs. Output Current

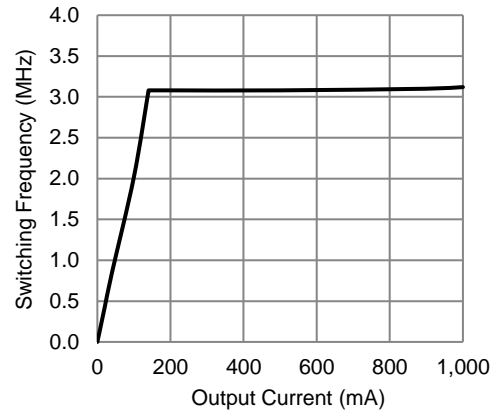

Output Voltage Accuracy vs Output Current

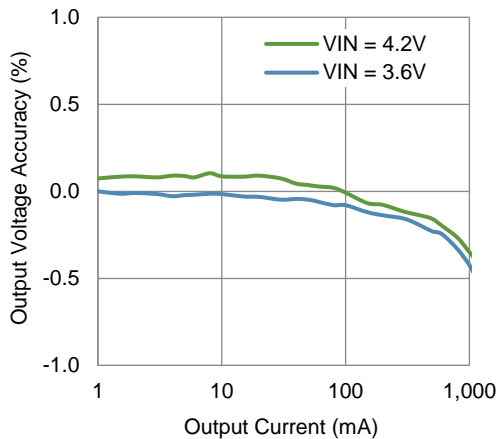

Boost Max Output Current vs  $V_{IN}$

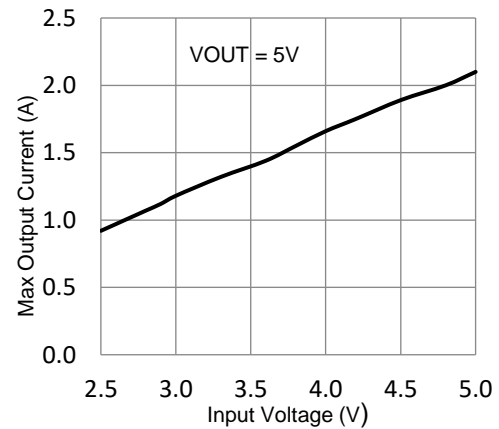

Boost Quiescent Current vs Input Voltage (no load)

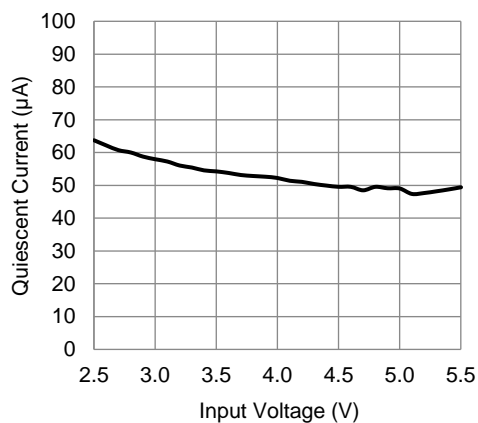

Pass Through Quiescent Current vs  $V_{IN}$  (no load,  $EN = Low$ ,  $PT = High$ )

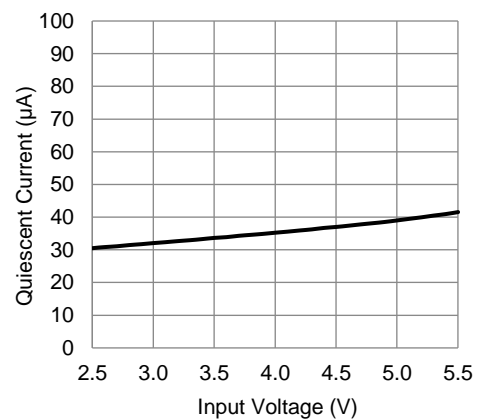

## Typical Characteristics (continued)

$V_{IN} = 3.6V$ ,  $V_{OUT} = 5V$ , EN = High, PT = Low,  $C_{OUT} = 22\mu F$ ,  $L = 1.0\mu H$  and  $T_A = 25^\circ C$  unless otherwise specified.

### DC Typical Characteristics

Output Ripple Voltage vs. Output Current

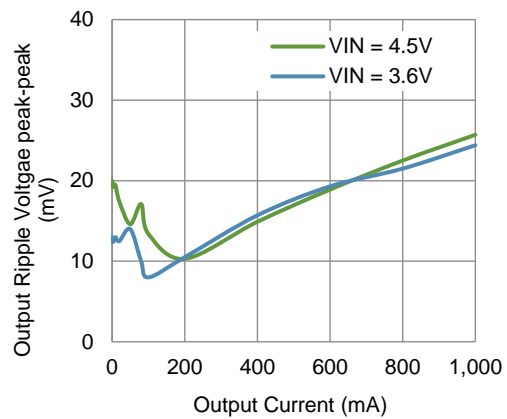



## Typical Characteristics (continued)

$V_{IN} = 3.6V$ ,  $V_{OUT} = 5V$ ,  $EN = High$ ,  $PT = Low$ ,  $C_{OUT} = 22\mu F$ ,  $L = 1.0\mu H$  and  $T_A = 25^\circ C$  unless otherwise specified.

### AC Typical Characteristics

Turn-on/off in Pass Through Mode ( $EN = low$ )  
with 0.2A load ( $20\Omega$ )

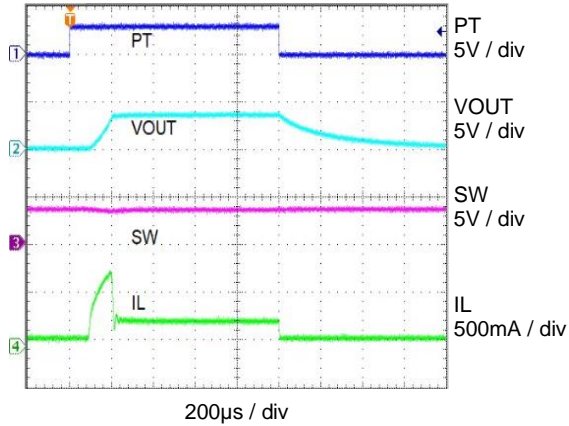

Turn-on in Boost Mode  
with 10mA load ( $500\Omega$ )

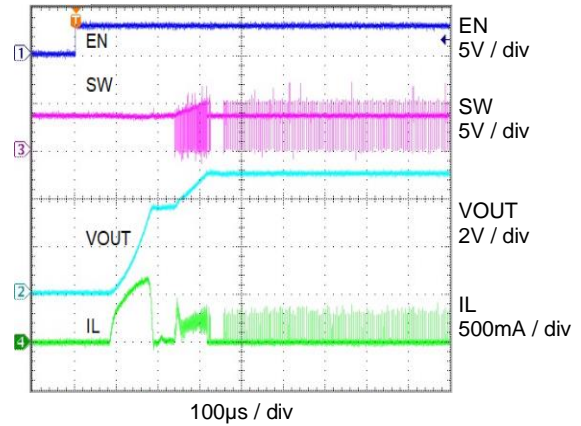

Switching waveform 50mA load (PFM mode)

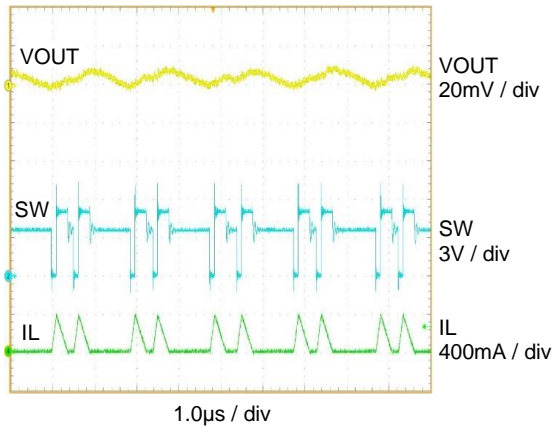

Switching waveform 200mA load (PWM mode)

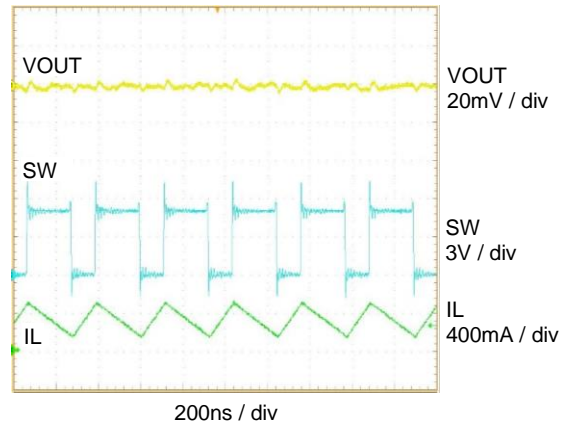

Load Step Response from 50mA to 500mA  
(PFM to PWM)

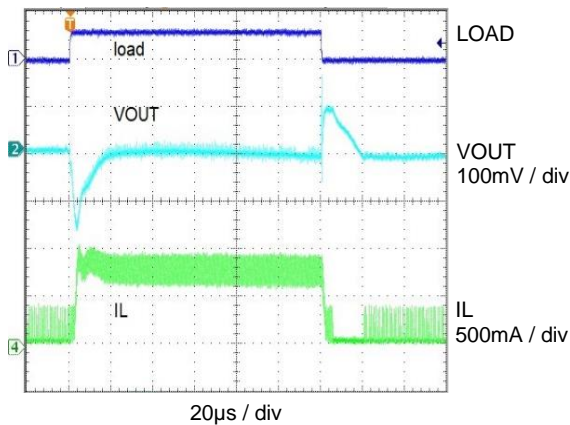

Line Transient  $V_{IN} 3.3V$  to  $3.9V$   
(500mA load)

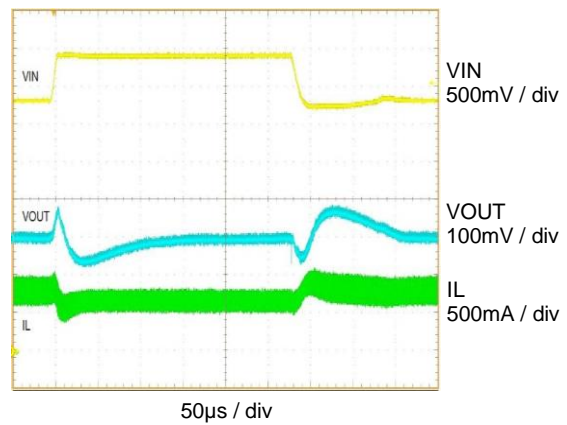

**Typical Characteristics (continued)**

$V_{IN} = 3.6V$ ,  $V_{OUT} = 5V$ , EN = High, PT = Low,  $C_{OUT} = 22\mu F$ ,  $L = 1.0\mu H$  and  $T_A = 25^\circ C$  unless otherwise specified.

**AC Typical Characteristics**

Load step from 0.5A to 1.5A (Current limiting)

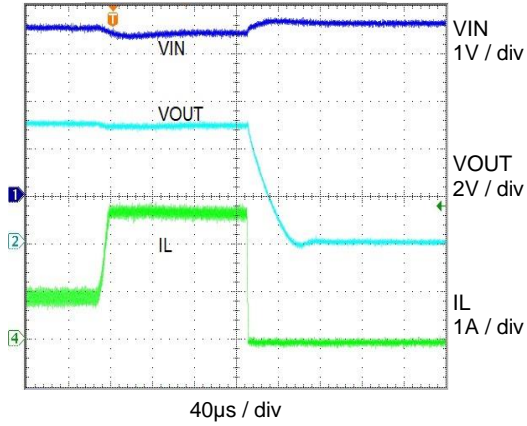

Current limiting with Hiccup (1.2A load)

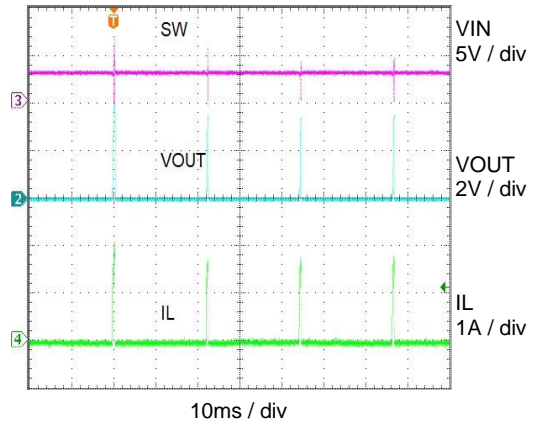

## Functional Description

### Overview

The KTC2110 is 3.0MHz synchronous boost converter with an additional Pass Through mode. In Boost mode, KTC2110 operates automatically either in PFM to achieve the best efficiency under light load, or in PWM for best line and load regulation under heavy load. KTC2110 enters Pass Through mode by pulling the PT pin high during shutdown state. In Pass Through mode,  $V_{OUT}$  is connected to  $V_{IN}$  supply via the inductor and the SW pin through the high-side MOSFET.

For the best load transient performance, KTC2110 uses a constant on-time control. At the beginning of each switching cycle, the low-side switch is turned on for an adaptive on-time to ramp-up the inductor current. At the end of the on-time, the high-side switch is turned-on and the inductor current decreases to a value determined by the compensation voltage. The switching cycle repeats by triggering the on timer again and turning on the low-side switch.

### Enable

When the EN input goes high, KTC2110 starts-up in soft-start phase. When EN goes low while PT pin is low, KTC2110 goes into true shutdown mode with  $V_{OUT}$  disconnected from  $V_{IN}$ . Setting the EN pin low and the PT pin high forces KTC2110 into Pass Through Mode.

### Boost Mode: Startup

The KTC2110 internal soft start circuit limits the inrush current during startup. The start-up first phase is Pre-charge, where the circuit takes about 200 $\mu$ s to ramp up the output voltage while the charging current increases within the 1.6A current limit. If after 200 $\mu$ s, the output voltage  $V_{OUT}$  is higher than 1V, the device keeps charging the output, otherwise a fault is declared. If the output voltage  $V_{OUT}$  reaches  $V_{IN}-0.3V$  within a 1ms charging time limit, the device enters the Soft-start phase, otherwise a fault is declared.

After successfully completing the Pre-charge phase, the next phase is Soft start where the boost regulator starts switching with 1.5A current limit. If the output  $V_{OUT}$  fails to reach regulation during soft start for more than 128 $\mu$ s, a fault is triggered. For larger output capacitor  $C_{OUT}$ , the output voltage ramp up speed is slower to avoid excessive input current. During Soft start phase, if  $V_{OUT} < V_{IN} - 0.3V$  and overcurrent is triggered, a fault will also be declared.

### Boost Mode: Normal Operation

In Boost mode, once the startup is successfully finished, KTC2110 enters normal operation. In Boost mode, KTC2110 can operate in Auto-Bypass once  $V_{IN} > V_{OUT\_NOM}$  (5V default) and no switching is detected for 5 $\mu$ s, the control scheme keeps  $V_{OUT}$  following  $V_{IN}$ . As soon as  $V_{IN}$  falls below  $0.98 \cdot V_{OUT\_NOM}$ , it resumes normal boost operation. KTC2110 can smoothly switch between auto-bypass state and boost state to keep  $V_{OUT}$  within regulation targets. In Auto-Bypass state, if the condition  $V_{OUT} < V_{IN} - 0.3V$  occurs, a fault is declared. In boost state, the switch valley current limit is increased to 2.3A. If the current limit happens for longer than 150 $\mu$ s, a fault is declared.

The KTC2110 features a valley current limit sensing scheme. Current limit control happens during the off-time by sensing the voltage drop across the high-side FET. The output voltage will be reduced when current limit happens, because the power stage operates in a limited current mode. The maximum continuous output current  $I_{OUT\_MAX}$  can be defined by below formula.

$$(1) I_{OUT\_MAX} = (1 - D) \cdot (I_{L\_VALLEY} + \frac{\Delta I_L}{2})$$

When the load current increases causing inductor valley current larger than the current limit threshold, the off-time is extended automatically to allow the inductor current to decrease to the valley current limit threshold before starting the next on-time cycle.

### Pass Through Mode: Startup

For startup under Pass Through mode (EN = low, PT = high), once startup successfully finished, KTC2110 enters Normal Operation. KTC2110 only has Pre-charge Phase. During Pre-charge, it takes 200 $\mu$ s to ramp up

the pre-charge current from 0A to its final value 1.6A. After 200us of 1.6A charging, if  $V_{OUT}$  is higher than 1V, device will keep charging the output otherwise a fault will be declared. After 1ms of 1.6A charging, if  $V_{OUT}$  is within  $V_{IN}-0.3V$ , it will come to Normal Operation, otherwise a fault will be declared.

### Pass Through Mode: Normal Operation

In Pass Through Mode ( $EN = 0$ ,  $PT = 1$ ), once Startup is successfully completed, KTC2110 enters normal operation where the high-side MOSFET is fully turned on. KTC2110 keeps the output voltage following the input voltage with only 35 $\mu$ A (typ) quiescent current. In this mode, if the condition  $V_{OUT} < V_{IN} - 0.3V$  is detected, a fault is declared.

**Table 1. Operating Mode Control**

OPERATING MODE	EN	PT
Shutdown, True Load Disconnect (SD)	0	0
Standby Pass Through Mode, Output Pre-Biased (SPTM)	0	1
Boost Operating Mode (BST)	1	x

### Fault State:

KTC2110 enters Fault state under any of the following conditions:

1.  $V_{OUT}$  fails to achieve the voltage required during Boost Mode/Pass Through Mode Pre-Charge Phase.
2.  $V_{OUT}$  fails to reach regulation for 128 $\mu$ s during Boost Mode Soft start Phase.
3.  $V_{OUT} < V_{IN} - 0.3V$  and overcurrent is triggered during Boost Mode Soft start Phase.
4. Boost current limit exceeded for 150 $\mu$ s during Boost Mode Normal Operation.
5.  $V_{OUT} < V_{IN} - 0.3V$  during Pass Through Mode Normal Operation or Boost Mode Auto-Bypass State and Boost State.
6.  $V_{IN} < \text{Input UVLO}$

Once a fault is triggered, the regulator stops switching and disconnects the path between  $V_{IN}$  and  $V_{OUT}$ . After 22ms hiccup period, it will automatically try to restart.

### Thermal Shutdown

As soon as the junction temperature  $T_j$  is higher than 150 $^{\circ}$ C (typ.), the device enters thermal shutdown mode where the power stage is turned-off. When  $T_j$  falls below 130 $^{\circ}$ C (typ.), the device turns back on.

## Application Information

### Recommended PCB Layout

KTC2110 is a high frequency switching regulator. Therefore the traces must be kept as short as possible between the inductor and the device SW pin. The input bypass capacitor C<sub>IN</sub> should be located as close as possible to the inductor and to the device in order to minimize the ripple voltage and improve the stability. The output capacitor C<sub>OUT</sub> must be located as close as possible to the IC in order to minimize the output ripple and improve the stability. It is recommended to connect both capacitors GND pads directly to the GND plane with a direct path to the device GND pins. Good layout practices should be used to avoid excessive noise spikes on SW pin which could cause voltages above Absolute Maximum Rating.

In order to support heavy load current and maximize the efficiency, it is important to keep traces wide on V<sub>IN</sub>, V<sub>OUT</sub> and on both sides of the inductor.

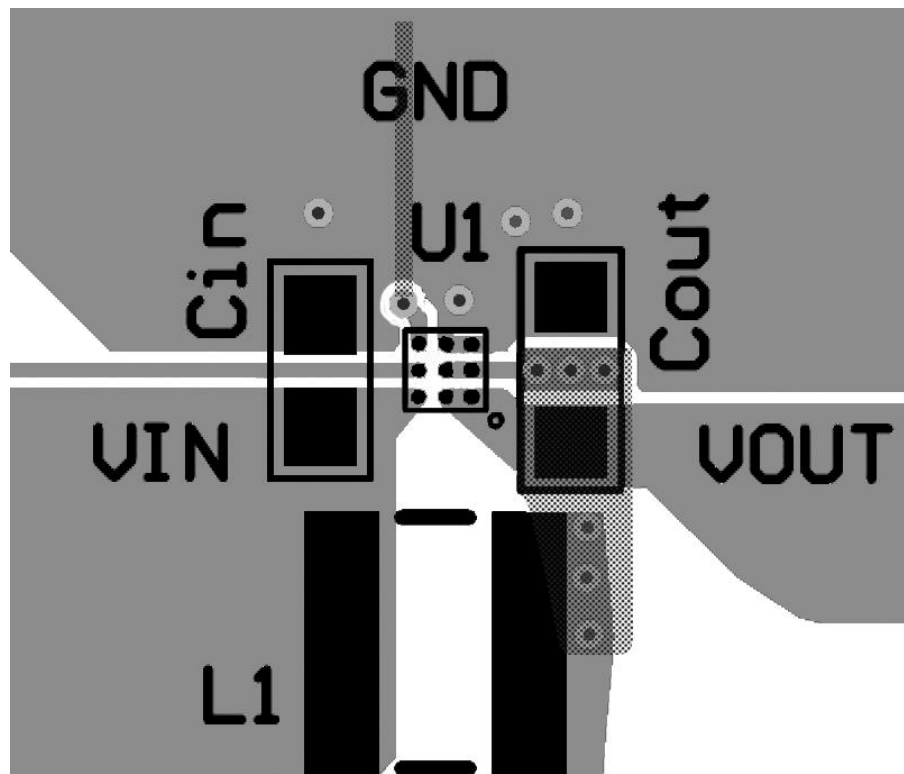
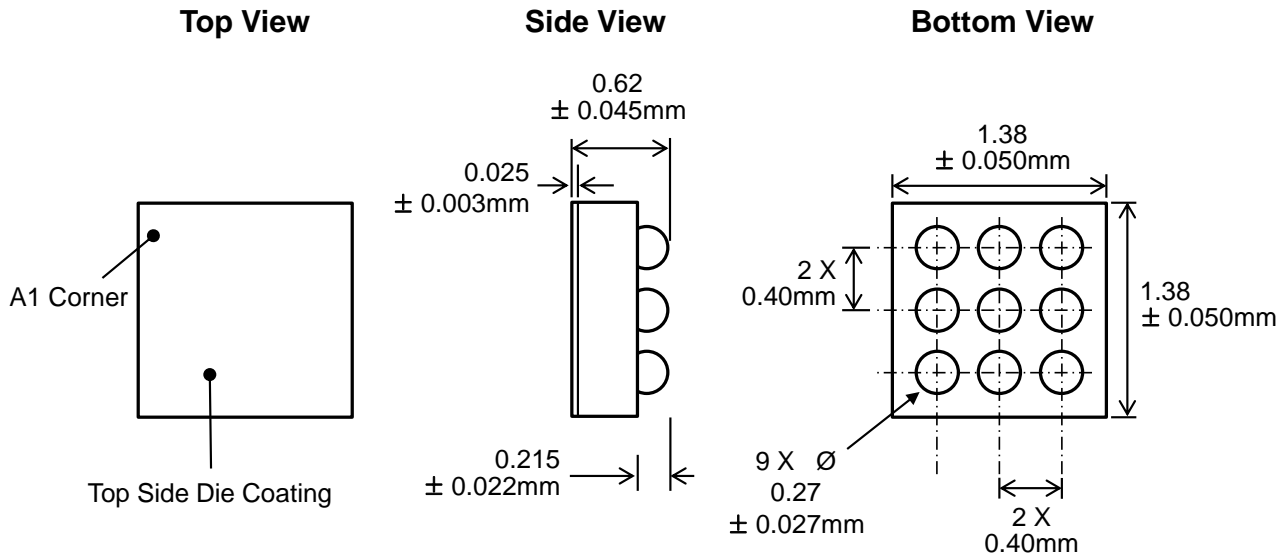

Figure 1. Recommended PCB Layout

**Packaging Information**

WLCSP33-9 (1.38mm x 1.38mm x 0.620mm)



**Recommended Footprint**

**(NSMD Pad Type)**

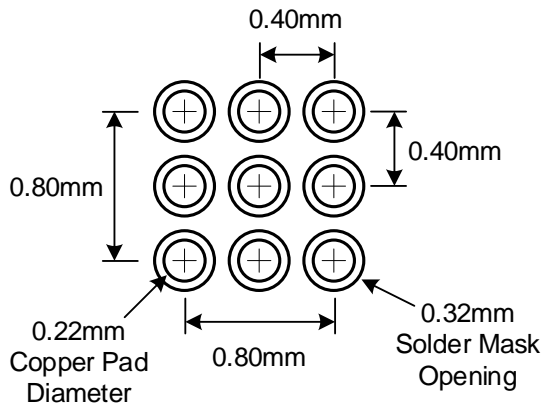

Kinetic Technologies cannot assume responsibility for use of any circuitry other than circuitry entirely embodied in a Kinetic Technologies product. No intellectual property or circuit patent licenses are implied. Kinetic Technologies reserves the right to change the circuitry and specifications without notice at any time