

## Fully integrated device transceiver IC

Data brief

### Features

- Supply voltage from 8 V to 32.5 V
- 2 programmable output stages: high-side, low-side or push-pull ( $< 4 \Omega$  @ 125 °C)
- Up to 230 kHz communication speed
- 2 industrial digital inputs, type 1 compliant and programmable filter
- Short-circuit and overcurrent outputs protection through current limitation and programmable cut-off current
- Overvoltage protection ( $>36$  V)
- 3.3 V/5 V selectable 50 mA linear regulator (with maximum power dissipation = 200 mW)
- On chip high efficiency adjustable 50 mA synchronous step-down switching regulator
- Control, configuration and diagnostic registers
- Diagnostic dual LED sequence generator and driver
- Internal clock generator with programmable frequency divider
- 5 V and 3.3 V compatible I/Os
- Integrated active reverse polarity protection with 200 mV @ 200 mA drop
- Integrated, IEC61000-4-5 surge protection, with source impedance 500  $\Omega$
- Overtemperature protection
- ESD protection
- Conform to IEC 61000-4-4
- Miniaturized: QFN 3.5 x 5 x 1 26 lead package

### Applications

- Industrial sensors power-stage
- 24 V push pull line driver
- Fast I/O PLC interface, IO-Link conform



### Description

The L6362 is a monolithic dual push pull Transceiver fully compliant to PHY2 (3 wires) supporting COM1 (4.8 kbaud), COM2 (38.4 kbaud) and COM3 (230.4 kbaud) modes. C/Q and I/Q output stages are programmable: high-side, low-side or push-pull; also cut-off current and cut-off current delay time are programmable. Cut-off current and cut-off current delay time combined with thermal shutdown and automatic re-start protect the device against overload and short circuit. C/Q and I/Q output stages are able to drive also inductive loads up to 10 mJ. Supply voltage is monitored and low voltage condition is detected. L6362 transfers/receives, through the PHY2, data received/transmitted in the digital block from sensor/actuator to/from the L6360 twin device. To enable full IC control, regarding configuration and monitoring (i.e. fault condition stored in the status register) the communication between the system microcontroller and L6362 is based on a high speed 2 wires interface. The L6362 has nine registers to manage the programmable parameters and the status of the IC. Monitored fault conditions are: Power On (L+ line), Overtemperature, C/Q overload, I/Q overload, linear regulator under-voltage and parity check. The fully integrated high precision oscillator, requiring an external resistor, provides internal clock as well as system clock Internal LED driver blocks, in open drain configuration, provide two programmable sequences to drive two LEDs. The integrated, high efficiency low power Step-down switching converter provides power supply to the IC and external circuits.

Figure 1. Block diagram

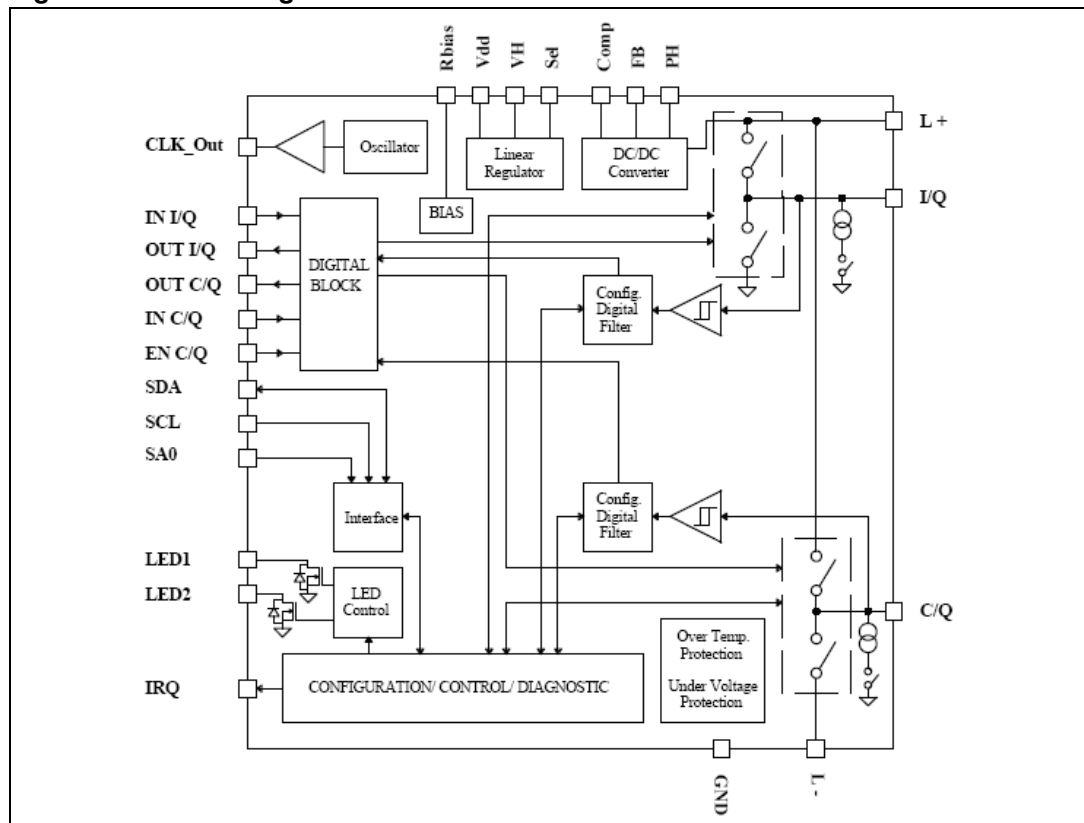

STMicroelectronics complete solution with device and master unit communicating with each other and with microcontrollers.

Figure 2. Application schematic

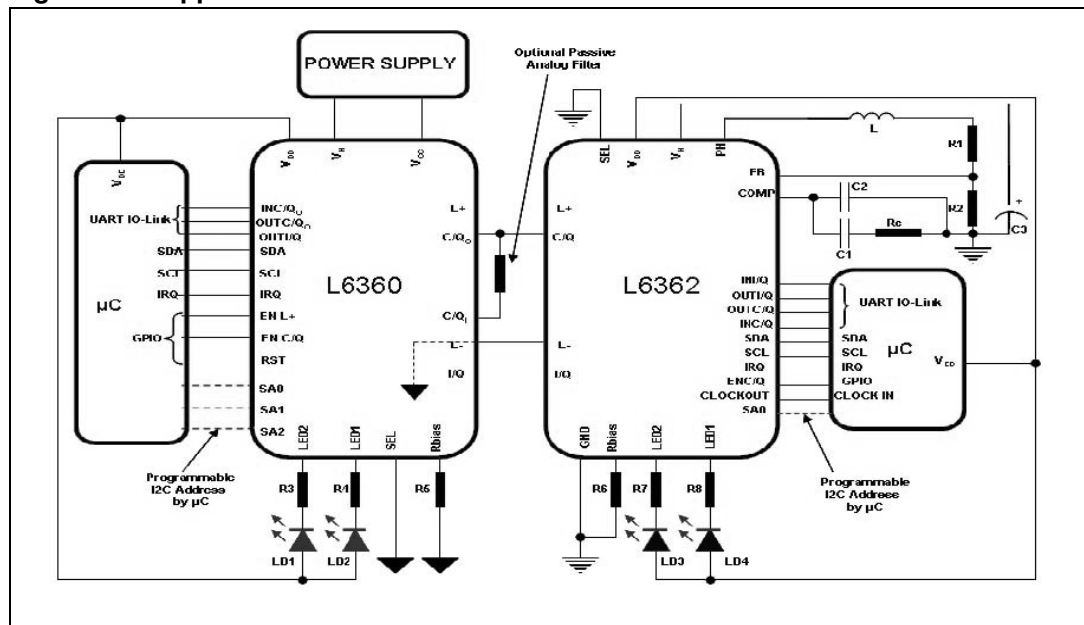

# 1 Revision history

**Table 1. Document revision history**

Date	Revision	Changes
23-Jul-2009	1	Initial release.

**Please Read Carefully:**

Information in this document is provided solely in connection with ST products. STMicroelectronics NV and its subsidiaries ("ST") reserve the right to make changes, corrections, modifications or improvements, to this document, and the products and services described herein at any time, without notice.

All ST products are sold pursuant to ST's terms and conditions of sale.

Purchasers are solely responsible for the choice, selection and use of the ST products and services described herein, and ST assumes no liability whatsoever relating to the choice, selection or use of the ST products and services described herein.

No license, express or implied, by estoppel or otherwise, to any intellectual property rights is granted under this document. If any part of this document refers to any third party products or services it shall not be deemed a license grant by ST for the use of such third party products or services, or any intellectual property contained therein or considered as a warranty covering the use in any manner whatsoever of such third party products or services or any intellectual property contained therein.

**UNLESS OTHERWISE SET FORTH IN ST'S TERMS AND CONDITIONS OF SALE ST DISCLAIMS ANY EXPRESS OR IMPLIED WARRANTY WITH RESPECT TO THE USE AND/OR SALE OF ST PRODUCTS INCLUDING WITHOUT LIMITATION IMPLIED WARRANTIES OF MERCHANTABILITY, FITNESS FOR A PARTICULAR PURPOSE (AND THEIR EQUIVALENTS UNDER THE LAWS OF ANY JURISDICTION), OR INFRINGEMENT OF ANY PATENT, COPYRIGHT OR OTHER INTELLECTUAL PROPERTY RIGHT.**

**UNLESS EXPRESSLY APPROVED IN WRITING BY AN AUTHORIZED ST REPRESENTATIVE, ST PRODUCTS ARE NOT RECOMMENDED, AUTHORIZED OR WARRANTED FOR USE IN MILITARY, AIR CRAFT, SPACE, LIFE SAVING, OR LIFE SUSTAINING APPLICATIONS, NOR IN PRODUCTS OR SYSTEMS WHERE FAILURE OR MALFUNCTION MAY RESULT IN PERSONAL INJURY, DEATH, OR SEVERE PROPERTY OR ENVIRONMENTAL DAMAGE. ST PRODUCTS WHICH ARE NOT SPECIFIED AS "AUTOMOTIVE GRADE" MAY ONLY BE USED IN AUTOMOTIVE APPLICATIONS AT USER'S OWN RISK.**

Resale of ST products with provisions different from the statements and/or technical features set forth in this document shall immediately void any warranty granted by ST for the ST product or service described herein and shall not create or extend in any manner whatsoever, any liability of ST.

ST and the ST logo are trademarks or registered trademarks of ST in various countries.

Information in this document supersedes and replaces all information previously supplied.

The ST logo is a registered trademark of STMicroelectronics. All other names are the property of their respective owners.

© 2009 STMicroelectronics - All rights reserved

STMicroelectronics group of companies

Australia - Belgium - Brazil - Canada - China - Czech Republic - Finland - France - Germany - Hong Kong - India - Israel - Italy - Japan - Malaysia - Malta - Morocco - Philippines - Singapore - Spain - Sweden - Switzerland - United Kingdom - United States of America

[www.st.com](http://www.st.com)