

DOOR ACTUATOR DRIVER

- ONE FULL BRIDGE FOR 6A LOAD ($r_{on} = 150m\Omega$)
- THREE HALF BRIDGES FOR 1.6A LOAD ($r_{on} = 800m\Omega$)
- ONE HIGHSIDE DRIVER FOR 6A LOAD ($r_{on} = 100m\Omega$)
- VERY LOW CURRENT CONSUMPTION IN STANDBY MODE ($I_S < 6\mu A$, typ. $T_j \leq 85^\circ C$)
- SERIAL PERIPHERAL INTERFACE (SPI) TO MICROCONTROLLER
- ALL OUTPUTS SHORT CIRCUIT PROTECTED
- CURRENT MONITOR OUTPUT FOR FULL BRIDGE AND HIGHSIDE DRIVER
- ALL OUTPUTS OVER TEMPERATURE PROTECTED
- OPEN LOAD DIAGNOSTIC FOR ALL OUTPUTS
- OVERLOAD DIAGNOSTIC FOR ALL OUTPUTS

APPLICATIONS

- FOR AUTOMOTIVE APPLICATIONS, E.G.

MULTIPOWER BCD60III TECHNOLOGY

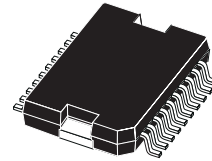

PowerSO20
ORDERING NUMBER: L9949

FULL BRIDGE FOR DOOR LATCH OR MIRROR RETRACT, HALF BRIDGES FOR MIRROR AXIS CONTROL AND HIGH-SIDE DRIVER FOR MIRROR DEFROSTER

DESCRIPTION

The L9949 is a microprocessor controlled power interface for automotive applications. It is realized in multipower BCD60III technology. Up to three DC mo-

BLOCK DIAGRAM

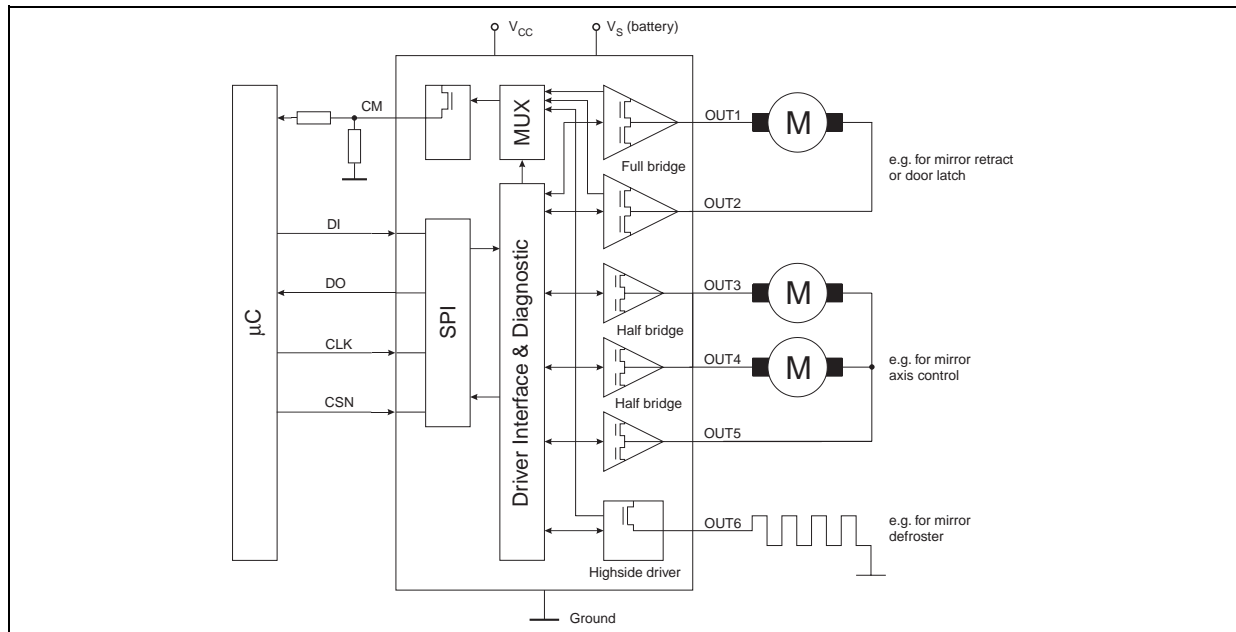

DESCRIPTION (continued)

tors and one grounded resistive load can be driven with its three half bridges, one full bridge and one highside driver power outputs. The integrated standard serial peripheral interface (SPI) controls all operation modes (forward, reverse, brake and high impedance). All diagnostic informations are available via the SPI.

Dual Power Supply: V_S and V_{CC}

The power supply voltage V_S supplies the full bridge, the half bridges and the highside driver. An internal charge-pump are used to drive the highside switches. The logic supply voltage V_{CC} (stabilized 5V) is used for the logic part and the SPI of the device. Due to the independent logic supply voltage the control and status information will not be lost, if there are temporary spikes or glitches on the power supply voltage. In case of power-on (V_{CC} increases from undervoltage to $V_{VCC\ OFF} = 4.2V$) the circuit is initialized by an internally generated power-on-reset (POR). If the voltage V_{CC} decreases under the minimum threshold ($V_{VCC\ ON} = 3.4V$), the outputs are switched to tristate (high impedance) and the status registers are cleared.

Standby-Mode

The standby mode of the L9949 is activated by setting the bits 12 and 13 of the Input Data Register to zero. All latched data will be cleared and the inputs and outputs are switched to high impedance. In the standby mode the current at V_S (V_{CC}) is less than typ. $6\mu A$ ($40\mu A$) for $CSN = high$ (DO in tristate). By switching the V_{CC} voltage a very low quiescent current can be achieved. If one of the bits 12 and 13 are set to high, the device will be switched to active mode.

Inductive Loads

Each half bridge is built by internally connected highside and a lowside power DMOS transistor. Due to the built-in reverse diodes of the output transistors inductive loads can be driven at the outputs OUT1 to OUT5 without external free-wheeling diodes. The highside driver OUT6 is intended to drive resistive loads only hence only a limited energie ($E < 1mJ$) can be dissipated by the internal ESD-diode in freewheeling condition. For inductive loads ($L > 100\mu H$) an external free-wheeling diode connected to GND and OUT6 is needed.

Diagnostic Functions

All diagnostic functions (over/open load, power supply over-/undervoltage, temperature warning and thermal shutdown) are internally filtered and the condition has to be valid for at least $10\mu s$ ($0.5ms$, respectively) before the corresponding status bit in the status registers will be set. The filters are used to improve the noise immunity of the device. The open load and temperature warning function are intended for information purpose and will not change the state of the output drivers. In contrast, the overload and thermal shutdown condition will disable the corresponding driver (overload) or all drivers (thermal shutdown), respectively. The microcontroller has to clear the status bits to reactivate the corresponding drivers. This is to avoid an uncontrolled switching behaviour of the device which may result in a heavy noise on the GND and V_S lines in case of an fault condition (e.g. short to GND or V_S).

Overvoltage and Undervoltage Detection

If the power supply voltage V_S rises above the overvoltage threshold $V_{SOV\ OFF}$ (max. 22V), the outputs OUT1 to OUT6 are switched to high impedance state to protect the load. If the supply voltage recovers to normal operating voltage, the device will return to the programmed state (lockout bit 14 = 0). When the voltage V_S drops below the undervoltage threshold $V_{SUV\ OFF}$ (min. 6V), the output stages are switched to high impedance to avoid the operation of the power devices without sufficient gate driving voltage (increased power dissipation). If the supply voltage V_S and the internal charge-pump recovers to normal operating voltage the system returns to the programmed state (lockout bit 14 = 0). If the lockout bit 14 is set, the automatic turn-on of the drivers is deactivated. The microcontroller needs to clear the status bits to reactivate the drivers.

Temperature Warning and Thermal Shutdown

When the junction temperature rises above T_{jTW} a temperature warning flag is set and is available via the SPI. If the junction temperature increases above the second threshold T_{jSD} , the thermal shutdown bit will be set and the power DMOS transistors of the output stages are switched off to protect the device. In order to reactivate the output stages the junction temperature must decrease below $T_{jSD} - T_{jSDHYS}$ and the thermal shutdown bit has to be cleared by the microcontroller.

Open Load Detection

The open load detection monitors the voltage drop of current sense resistors in each highside and lowside driver of the output stage. The output signal of an open load comparator has to be valid for at least 0.5 ms (t_{dOL}) to set the open load bit (bit 1-11) in the status register 1.

Over Load Detection

In the case of an overcurrent condition an overcurrent flag (bit 1-11) is set in the status register 0 in the same way as open load detection. If the overcurrent signal is valid for at least $t_{ISC} = 10\mu s$, the overcurrent flag is set and the corresponding driver is switched off to reduce the power dissipation and to protect the integrated circuit. The microcontroller has to clear the status bits to reactivate the corresponding driver.

Current monitor

The current monitor output sources a current image at the current monitor output which has a fixed ratio (1/10000) of the instantaneous current of the selected highside driver. The bits 12 and 13 of the Input Data register controls which of the outputs OUT1, OUT2 and OUT6 will be multiplexed to the current monitor output. The current monitor output allows a more precise analyse of the actual state of the load rather than the detection of an open- or overload condition. For example this can be used to detect the motor state (free-running, loaded or blocked) or the temperature of the heating element.

Figure 1. Pin Connection (Top view)

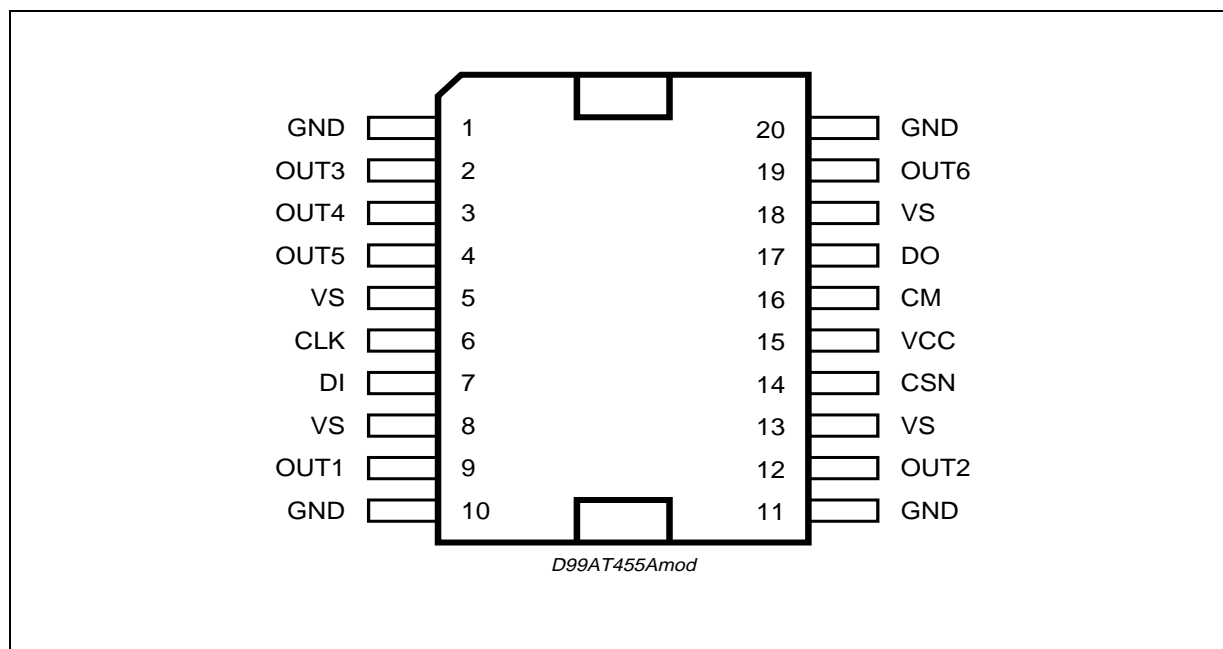

PIN FUNCTION

N°	Pin	Description
1, 10, 11, 20	GND	Ground: Reference potential Important: For the capability of driving the full current at the outputs all pins of GND must be externally connected !
5, 8, 13, 18	V _S	Power supply voltage (battery): For this input a ceramic capacitor as close as possible to GND is recommended. Important: For the capability of driving the full current at the outputs all pins of V _S must be externally connected !
15	V _{CC}	Logic supply voltage: For this input a ceramic capacitors as close as possible to GND are recommended.
14	CSN	Chip Select Not input: This input is low active and requires CMOS logic levels. The serial data transfer between L9949 and micro controller is enabled by pulling the input CSN to low level. If an input voltage of more than 9.6V above V _{CC} is applied to CSN pin the L9949 will be switched into a test mode.
6	CLK	Serial clock input: This input controls the internal shift register of the SPI and requires CMOS logic levels.
7	Data In	Serial data input: The input requires CMOS logic levels and receives serial data from the microcontroller. The data is an 16bit control word and the least significant bit (LSB, bit 0) is transferred first.
17	Data Out	Serial data output: The diagnosis data is available via the SPI and this tristate-output. The output will remain in tristate, if the chip is not selected by the input CSN (CSN = high)
16	CM	Current monitor output: Depending on the multiplexer bits 12 and 13 of the Input Data register this output sources an image of the instant current through the corresponding highside driver with a ratio of 1/10000
9	OUT1	Halfbridge-output 1: The output is built by a highside and a lowside switch, which are internally connected. The output stage of both switches is a power DMOS transistor. Each driver has an internal parasitic reverse diode (bulk-drain-diode, highside driver from OUT1 to V _S , lowside driver from GND to OUT1). This output is overcurrent and open load protected.
12	OUT2	Halfbridge-output 2: → see OUT1 (pin 9)
2	OUT3	Halfbridge-output 3: The output is built by a highside and a lowside switch, which are internally connected. The output stage of both switches is a power DMOS transistor. Each driver has an internal parasitic reverse diode (bulk-drain-diode, highside driver from OUT3 to V _S , lowside driver from GND to OUT3). This output is overcurrent and open load protected.
3	OUT4	Halfbridge-output 4: → see OUT3 (pin 2)
4	OUT5	Halfbridge-output 5: → see OUT3 (pin 2)
19	OUT6	Highside-driver-output 6: The output is built by a highside switch and can be used only for a resistive load, because the internal reverse diode from GND to OUT6 is missing. This highside switch is a power DMOS transistor with an internal parasitic reverse diode from OUT6 to V _S (bulk-drain-diode). The output is overcurrent and open load protected.

ABSOLUTE MAXIMUM RATINGS

Symbol	Parameter	Value	Unit
V _S	DC supply voltage	-0.3...28	V
	single pulse t _{max} < 400 ms	40	V
V _{CC}	stabilized supply voltage, logic supply	-0.3 to 6	V
V _{DI} , V _{DO} , V _{CLK} , V _{CSN}	digital input / output voltage	-0.3 to V _{CC} + 0.3	V
V _{CM}	current monitor output	-0.3 to V _{CC} + 0.3	V
I _{OUT1,OUT2} , I _{OUT6}	output current	±10	A
I _{OUT3,OUT5}	output current	±5	A

Note: All maximum ratings are absolute ratings. Leaving the limitation of anyone of these values may cause an irreversible damage of the integrated circuit!

ESD PROTECTION

Parameter	Value	Unit
All pins	±2 ⁽¹⁾	kV
output pins: OUT1 – OUT6	±4 ⁽²⁾	kV

(1) HBM according to MIL 883C, Methode 3015.7 or EIA/JESD22-A114-A

(2) HBM with all unzapped pins grounded

THERMAL DATA

Symbol	Parameter	Value	Unit
--------	-----------	-------	------

Operating junction temperature:

T _j	Operating Junction Temperature	-40 to 150	°C
----------------	--------------------------------	------------	----

Temperature warning and thermal shutdown:

Symbol	Parameter		Min.	Typ.	Max.	Unit
T _{JTW ON}	Temperature Warning Threshold Junction Temperature	T _j increasing			150	°C
T _{JTW OFF}	Temperature Warning Threshold Junction Temperature	T _j decreasing	120			°C
T _{JTW HYS}	Temperature Warning Hysteresis			10		K
T _{JSD ON}	Thermal Shutdown Threshold Junction Temperature	T _j increasing			180	°C
T _{JSD OFF}	Thermal Shutdown Threshold Junction Temperature	T _j decreasing	150			°C
T _{JSD HYS}	Thermal Shutdown Hysteresis			10		K

Figure 2. Thermal Data of Package

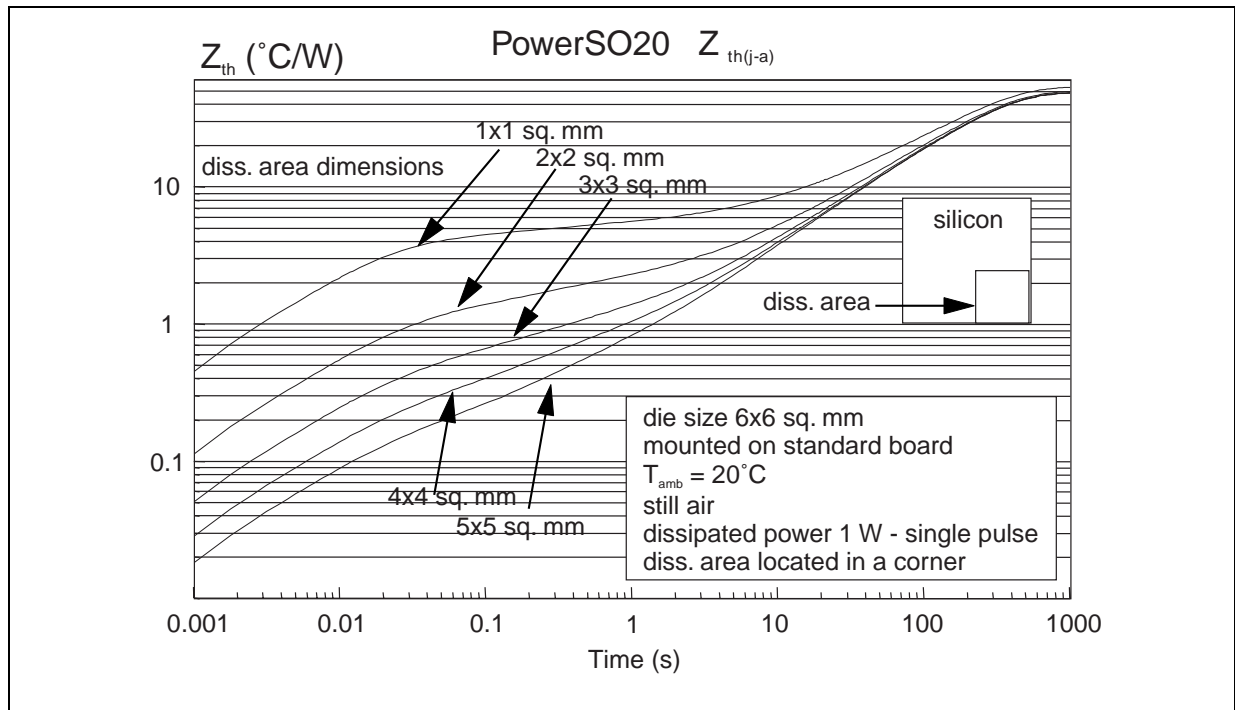

ELECTRICAL CHARACTERISTICS

$V_S = 8$ to 16 V, $V_{CC} = 4.5$ to 5.5 V, $T_j = -40$ to 150 $^{\circ}\text{C}$, unless otherwise specified. The voltages are referred to GND and currents are assumed positive, when the current flows into the pin.

Symbol	Parameter	Test Condition	Min.	Typ.	Max.	Unit
--------	-----------	----------------	------	------	------	------

Supply

V_S	Operating Supply Voltage Range		7		28	V
I_S	DC Supply Current	active mode, $V_S = 16$ V, $V_{CC} = 5.3$ V, OUT1 - OUT6 floating		7	20	mA
	Quiescent Supply Current	standby mode, $V_S = 16$ V, $V_{CC} = 0$ V, $T_j < 85$ $^{\circ}\text{C}^{(1)}$ OUT1 - OUT6 floating		6	12	μA
I_{CC}	DC Supply Current	active mode, $CSN = V_{CC}$, $V_S = 16$ V; $V_{CC} = 5.3$ V		1	2	mA
	Quiescent Supply Current	standby mode, $CSN = V_{CC}$, $V_S = 16$ V, $V_{CC} = 5.3$ V, $T_j < 85$ $^{\circ}\text{C}^{(1)}$ OUT1 - OUT6 floating		40	75	μA
$I_S + I_{CC}$	Sum Supply Quiescent Current	standby mode, $CSN = V_{CC}$, $V_S = 16$ V, $V_{CC} = 5.3$ V, $T_j < 85$ $^{\circ}\text{C}$ OUT1 - OUT6 floating		50	90	μA

ELECTRICAL CHARACTERISTICS (continued)

$V_S = 8$ to 16 V, $V_{CC} = 4.5$ to 5.5 V, $T_j = -40$ to 150 °C, unless otherwise specified. The voltages are referred to GND and currents are assumed positive, when the current flows into the pin.

Symbol	Parameter	Test Condition	Min.	Typ.	Max.	Unit
--------	-----------	----------------	------	------	------	------

(1) Parameter is measured at -40 °C and 25 °C. Value for 85 °C is guaranteed by design

Over- and undervoltage detection

$V_{SUV\ ON}$	V_S UV-Threshold Voltage	V_S increasing			7.6	V
$V_{SUV\ OFF}$	V_S UV-Threshold Voltage	V_S decreasing	6			V
$V_{SUV\ hyst}$	V_S UV-hysteresis	$V_{SUV\ ON} - V_{SUV\ OFF}$		0.6		V
$V_{SOV\ OFF}$	V_S OV-threshold voltage	V_S increasing			22	V
$V_{SOV\ ON}$	V_S OV-threshold voltage	V_S decreasing	18			V
$V_{SOV\ hyst}$	V_S OV-hysteresis	$V_{SOV\ OFF} - V_{SOV\ ON}$		1		V
$V_{VCC\ OFF}$	Power-on-reset Threshold	V_{CC} increasing			4.2	V
$V_{VCC\ ON}$	Power-on-reset Threshold	V_{CC} decreasing	3.4		4	V
$V_{VCC\ hyst}$	Power-on-reset Hysteresis	$V_{VCC\ OFF} - V_{VCC\ ON}$		0.3		V

Current Monitor Output

V_{CM}	Functional Voltage Range	$V_{CC} = 5$ V	0		4	V
$I_{CM,r}$	Current Monitor Output Ratio: $I_{CM} / I_{OUT1,2,6}$	$0\text{ V} \leq V_{CM} \leq 4\text{ V}$		$\frac{1}{10000}$		-
$I_{CM\ acc}$	Current Monitor Accuracy	$0\text{ V} \leq V_{CM} \leq 4\text{ V}$, $I_{CM} = 50\mu\text{A}, 600\mu\text{A}$ (FS=full scale=600 μA)		4% + 1%FS	8% + 2%FS	

Outputs: OUT1 - OUT6

$R_{ON\ OUT1}$	On-resistance to Supply or GND	$V_S = 13.5$ V, $T_j = 25$ °C, $I_{OUT1} = \pm 3.0$ A			150	m Ω
		$V_S = 13.5$ V, $T_j = 125$ °C, $I_{OUT1} = \pm 3.0$ A			225	m Ω
		$V_S = 8.0$ V, $T_j = 25$ °C, $I_{OUT1} = \pm 3.0$ A			180	m Ω
$R_{ON\ OUT2}$	On-resistance to Supply or GND	$V_S = 13.5$ V, $T_j = 25$ °C, $I_{OUT2} = \pm 3.0$ A			150	m Ω
		$V_S = 13.5$ V, $T_j = 125$ °C, $I_{OUT2} = \pm 3.0$ A			225	m Ω
		$V_S = 8.0$ V, $T_j = 25$ °C, $I_{OUT2} = \pm 3.0$ A			180	m Ω

ELECTRICAL CHARACTERISTICS (continued)

$V_S = 8$ to 16 V, $V_{CC} = 4.5$ to 5.5 V, $T_j = -40$ to 150 °C, unless otherwise specified. The voltages are referred to GND and currents are assumed positive, when the current flows into the pin.

Symbol	Parameter	Test Condition	Min.	Typ.	Max.	Unit
R _{ON OUT3}	On-resistance to Supply or GND	$V_S = 13.5$ V, $T_j = 25$ °C, $I_{OUT3} = \pm 0.8$ A			800	mΩ
		$V_S = 13.5$ V, $T_j = 125$ °C, $I_{OUT3} = \pm 0.8$ A			1250	mΩ
		$V_S = 8.0$ V, $T_j = 25$ °C, $I_{OUT3} = \pm 0.8$ A			980	mΩ
R _{ON OUT4}	On-resistance to Supply or GND	$V_S = 13.5$ V, $T_j = 25$ °C, $I_{OUT4} = \pm 0.8$ A			800	mΩ
		$V_S = 13.5$ V, $T_j = 125$ °C, $I_{OUT4} = \pm 0.8$ A			1250	mΩ
		$V_S = 8.0$ V, $T_j = 25$ °C, $I_{OUT4} = \pm 0.8$ A			980	mΩ
R _{ON OUT5}	On-resistance to Supply or GND	$V_S = 13.5$ V, $T_j = 25$ °C, $I_{OUT5} = \pm 0.8$ A			800	mΩ
		$V_S = 13.5$ V, $T_j = 125$ °C, $I_{OUT5} = \pm 0.8$ A			1250	mΩ
		$V_S = 8.0$ V, $T_j = 25$ °C, $I_{OUT5} = \pm 0.8$ A			980	mΩ
R _{ON OUT6}	On-resistance to Supply	$V_S = 13.5$ V, $T_j = 25$ °C, $I_{OUT6} = - 2.5$ A			100	mΩ
		$V_S = 13.5$ V, $T_j = 125$ °C, $I_{OUT6} = - 2.5$ A			150	mΩ
		$V_S = 8.0$ V, $T_j = 25$ °C, $I_{OUT6} = - 2.5$ A			120	mΩ
I _{OUT1}	Output Current Limitation to Supply or GND	sink and source, current ramp	6		10	A
I _{OUT2}	Output Current Limitation to Supply or GND	sink and source, current ramp	6		10	A
I _{OUT3}	Output Current Limitation to Supply or GND	sink and source, current ramp	1.6		2.5	A
I _{OUT4}	Output Current Limitation to Supply or GND	sink and source, current ramp	1.6		2.5	A
I _{OUT5}	output current limitation to Supply or GND	sink and source, current ramp	1.6		2.5	A
I _{OUT6}	Output Current Limitation to GND	source, current ramp	6.3		11	A
I _{OUT6/resl}	Output Current Limitation to GND switching into resistive load	source, switching into resistive load, go-nogo test	5.1		11	A

For details of the on-resistance (R_{on} over temperature) see the figures „Typical r_{on} characteristics“ for the differential output stages (FIGURE 3, FIGURE 4, FIGURE 5)

Figure 3. TYPICAL R_{ON} CHARACTERISTICS OUT1,2Figure 4. TYPICAL R_{ON} CHARACTERISTICS OUT3,4,5

Figure 5. TYPICAL R_{ON} CHARACTERISTICS OUT6**ELECTRICAL CHARACTERISTICS**

$V_S = 8$ to 16 V, $V_{CC} = 4.5$ to 5.5 V, $T_J = -40$ to 150 °C, unless otherwise specified. The voltages are referred to GND and currents are assumed positive, when the current flows into the pin.

Symbol	Parameter	Test Condition	Min.	Typ.	Max.	Unit
OUTPUTS: OUT1 - OUT6						
$t_{d\ ON\ H}$	Output Delay Time, Highside Driver On	$V_S = 13,5$ V corresponding low side driver is not active	20	40	80	μ s
$t_{d\ OFF\ H}$	Output Delay Time, Highside Driver Off	$V_S = 13,5$ V	80	150	300	μ s
$t_{d\ ON\ L}$	Output Delay Time, Lowside Driver On	$V_S = 13,5$ V corresponding highside driver is not active	20	40	80	μ s
$t_{d\ OFF\ L}$	Output Delay Time, Lowside Driver Off	$V_S = 13.5$ V	80	150	300	μ s
$t_{D\ HL}$	Dead Time, Source to Sink	$t_{d\ ON\ L}$ (HS was on) - $t_{d\ OFF\ H}$	5		200	μ s
$t_{D\ LH}$	Dead Time, Sink to Source	$t_{d\ ON\ H}$ (LS was on) - $t_{d\ OFF\ L}$	5		200	μ s
I_{QLH}	Leakage Current Highside Drivers of OUT1-6	$V_{OUT1-6} = 0$ V, standby mode	0	2	5	μ A
		$V_{OUT1-6} = 0$ V, active mode	-40	-15	0	μ A
I_{QLL}	Leakage Current Lowside Drivers of OUT1-5	$V_{OUT1-5} = V_S$, standby mode	0	7	20	μ A
		$V_{OUT1-5} = V_S$, active mode	-40	-15	0	μ A

ELECTRICAL CHARACTERISTICS (continued)

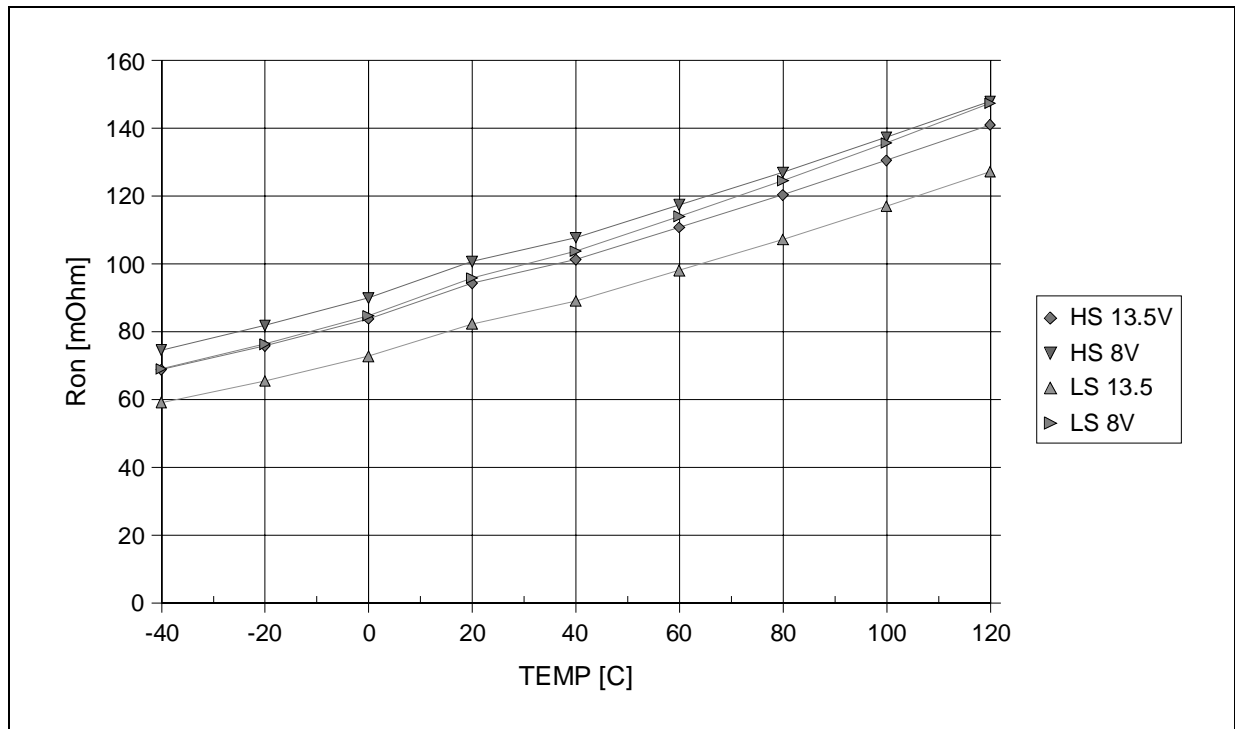
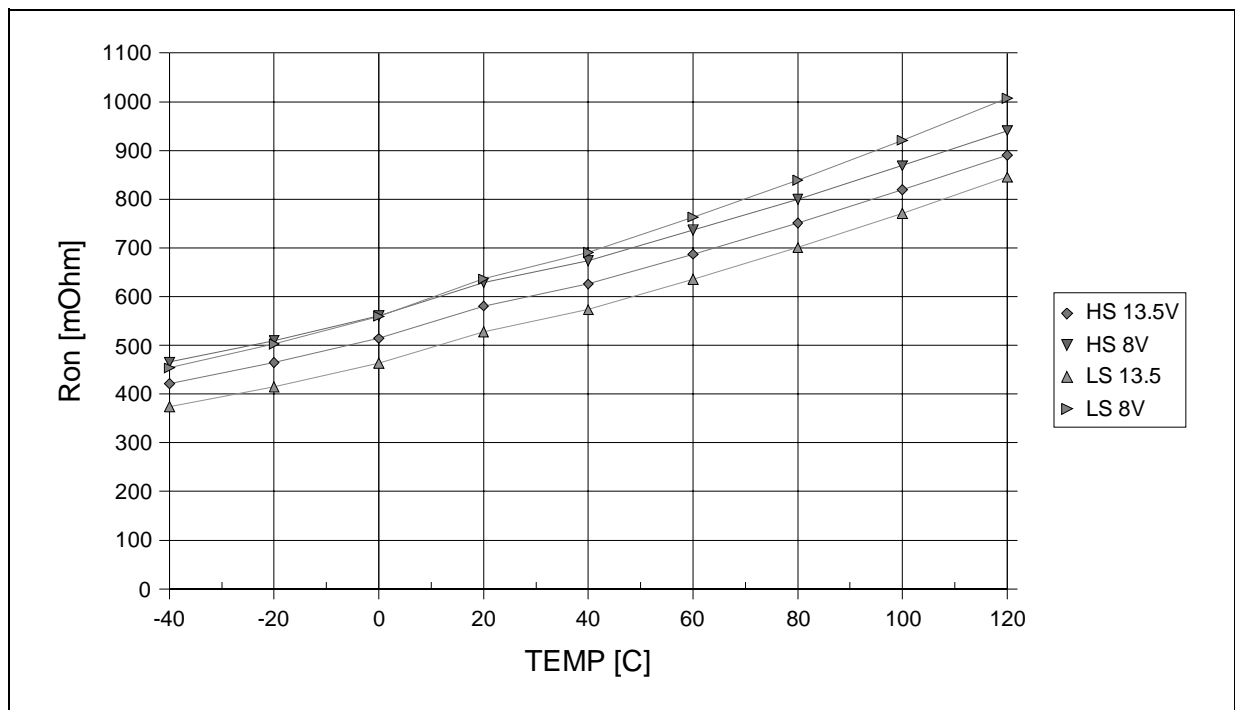
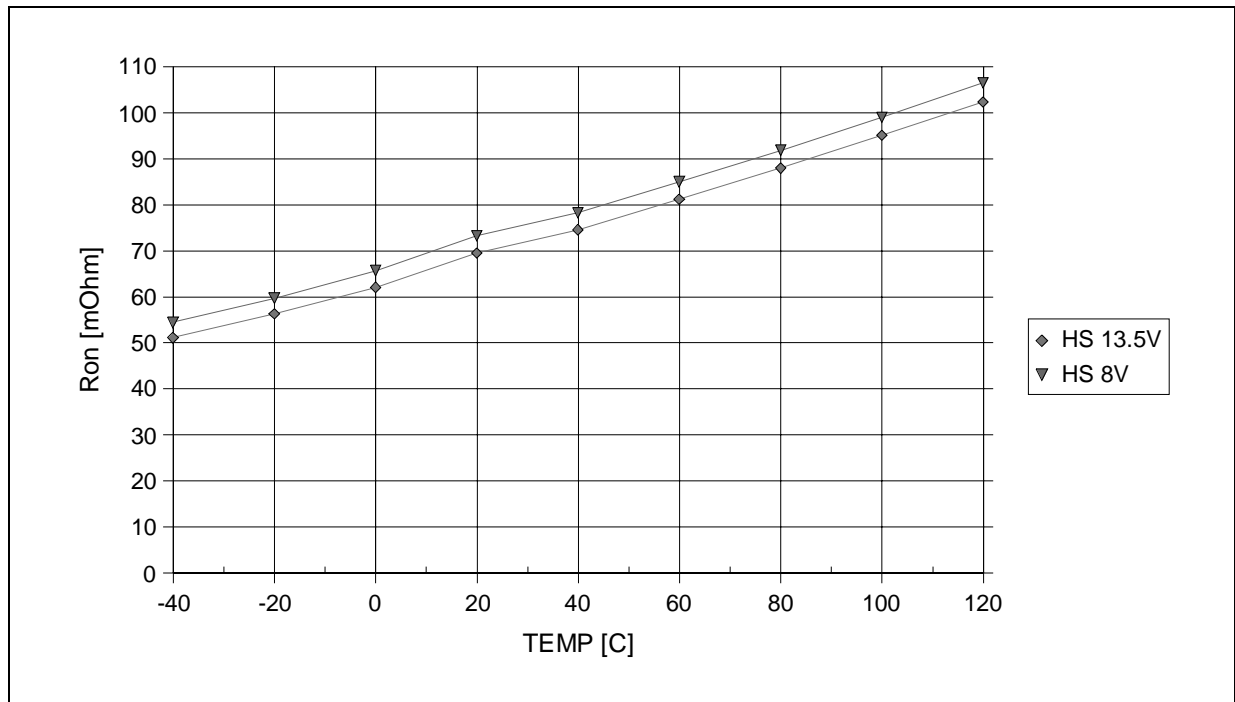
$V_S = 8$ to 16 V, $V_{CC} = 4.5$ to 5.5 V, $T_j = -40$ to 150 °C, unless otherwise specified. The voltages are referred to GND and currents are assumed positive, when the current flows into the pin.

Symbol	Parameter	Test Condition	Min.	Typ.	Max.	Unit
OUTPUTS: OUT1 - OUT6						
I_{OLD12}	Open Load Detection Current of OUT1 and OUT2		80	160	320	mA
I_{OLD345}	Open load detection current of OUT3, OUT4 and OUT5		20	40	60	mA
I_{OLD6}	open load detection current of OUT6		60	160	320	mA
t_{dOL}	minimum duration of open load condition to set the status bit		500		3000	μ s
t_{ISC}	minimum duration of overcurrent condition to switch off the driver		10		100	μ s
dV_{OUT12}/dt	slew rate of OUT1 and OUT2	$V_S = 13.5$ V, for highside driver: $I_{load} = -3$ A, for lowside driver: $I_{load} = 3$ A	0.1	0.2	0.4	V/ μ s
dV_{OUT345}/dt	slew rate of OUT3, OUT4 and OUT5	$V_S = 13.5$ V, for highside driver: $I_{load} = -0.8$ A, for lowside driver: $I_{load} = 0.8$ A	0.09	0.2	0.4	V/ μ s
dV_{OUT6}/dt	slew rate of OUT6	$V_S = 13.5$ V, $I_{load} = -2.5$ A	0.1	0.2	0.4	V/ μ s

Figure 6. Application Circuit Diagram

Figure 7. Functional Block Diagram



FUNCTIONAL DESCRIPTION OF THE SPI

Serial Peripheral Interface (SPI)

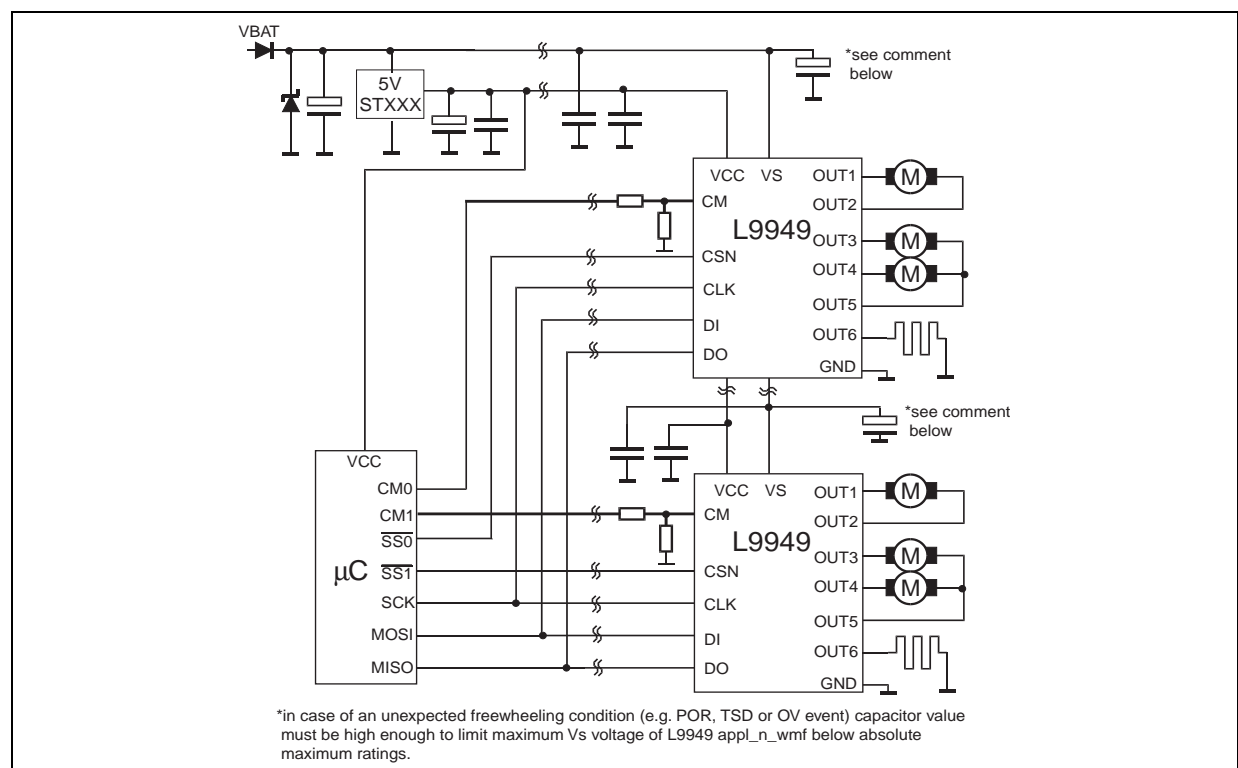
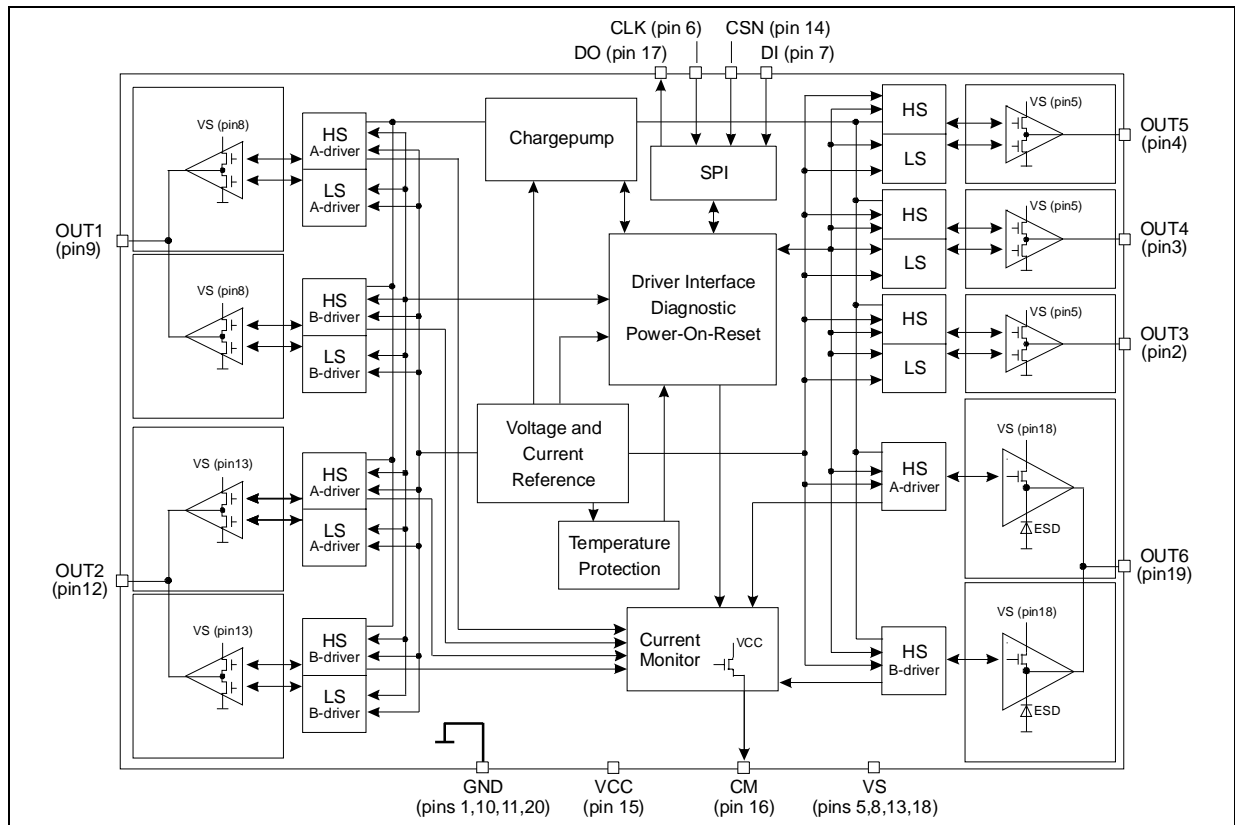
This device uses a standard SPI to communicate with a microcontroller. The SPI can be driven by a microcontroller with its SPI peripheral running in either of the two following modes: CPOL = CPHA = 0 or CPOL = CPHA = 1.

For these two modes, input data is sampled by the low to high transition of the clock CLK, and output data is changed from the high to low transition of CLK.

The difference of these two modes is the standby polarity of the CLK. For CPOL = 0 the CLK remains low and for CPOL = 1 the CLK remains high.

This device is not limited to microcontrollers with a build-in SPI. Only three CMOS-compatible output pins and one input pin will be needed to communicate with the device. A fault condition can be detected by setting CSN to low. If CSN = 0, the DO-pin will reflect the status bit 0 (fault condition) of the device which is a logical-or of all bits in the status registers 0 and 1. The microcontroller can poll the status of the device without the need of a full SPI-communication cycle.

Note: In contrast to the SPI-standard the least significant bit (LSB) will be transferred first (see. FIGURE 8).

Chip Select not (CSN)

The input pin is used to select the serial interface of this device. When CSN is high, the output pin (DO) will be in high impedance state. A low signal will activate the output driver and a serial communication can be started.

Serial Data In (DI)

The input pin is used to transfer data serial into the device. The data applied to the DI will be sampled at the

rising edge of the CLK signal and shifted into an internal 16 bit shift register. At the rising edge of the CSN signal the contents of the shift register will be transferred to Data Input Register (see FIGURE 8).

The SPI uses an internal 16 bit counter which will be reset at the rising edge of the CSN signal. Only the first 16 bits of the data input DI will be relevant. If more than 16 bits are transferred the trailing bits will be ignored.

Serial Data Out (DO)

The output driver is activated by a logical low level at the CSN input and will go from high impedance to a low or high level depending on the status bit 0 (fault condition). The first rising edge of the CLK input after a high to low transition of the CSN pin will transfer the content of the selected status register into the data out shift register. Each subsequent falling edge of the CLK will shift the next bit out.

Serial Clock (CLK)

The CLK input is used to synchronize the input and output serial bit streams. The data input (DI) is sampled at the rising edge of the CLK and the data output (DO) will change with the falling edge of the CLK signal (see FIGURE 8).

Input Data Register

After the rising edge of CSN the contents of the input shift register will be written to the input data register. Depending on bit 0 the contents of the selected status register will be transferred to DO during the current communication cycle. Bit 1-11 controls the behaviour of the corresponding driver. If bit 12 and bit 13 are zero, the device will go into the standby-mode. If at least one of both bits are one these bits will be used to control the current monitor multiplexer. Bit 14 selects the V_S lockout mode. If this bit is set, an over- or undervoltage condition at the power supply V_S will disable all driver stages until the status bit will be cleared by the microcontroller. Bit 15 is used to reset all status bits in both status registers. The bits in the status registers will be cleared after the current communication cycle (rising edge of CSN).

Status Register

This device uses two status registers to store and to monitor the state of the device. Bit 0 is used as a fault bit and is a logical-NOR combination of all other bits in both status registers. The state of this bit can be polled by the microcontroller without the need of a full SPI-communication cycle (see FIGURE 13). If one of the overcurrent bits is set, the corresponding driver will be disabled. The microcontroller has to clear the overcurrent bit to enable the driver. If the thermal shutdown bit is set, all drivers will go into a high impedance state. Again the microcontroller has to clear the bit to enable the drivers. The behaviour of the device in case of an over- or undervoltage condition will depend on the V_S lockout bit (bit 14) in the input data register. If bit 14 is cleared, the device will reactivate the drivers if the power supply V_S returns to normal operating range. In this case no interaction from the microcontroller is needed.

Test Mode

Due to the current limitations of a single bond wire the output stages OUT1, 2 and 6 need two bond wires in parallel. For the full output current driving capability it is necessary to check that both bond wires are connected correctly to the lead frame. Therefore the drivers and DMOS-transistors of the outputs OUT1, 2 and 6 are splitted into two independent stages, one for each bond wire (see FIGURE 6.4). In normal operating mode the splitted outputs are connected in parallel. In the test mode bit 5 and 6 of the input data register select the A-driver, bit 7 and 8 the B-driver. If all four bits (5 - 8) are switched to high level, no driver will be activated. For all combinations beside both high of bit 5 and 6 or bit 7 and 8 the output stages OUT3 and OUT4 are controlled like in normal operating mode. In any case the output stages are protected against shoot through current. Furthermore the inputs CLK and DI are connected by an OR to the output DO for testing the threshold voltages and the hysteresis. The input CLK can be tested by clamping the input DI to low level and vice versa.

SPI Interface – Input Data and Status Register

Input Data Register				Status Register		
BIT	Function			BIT	Function	
					Register 0	Register 1
15	High level reset all bits in selected status register			15	always H	always H
14	V _S under- / overvoltage lockout bit			14	V _S overvoltage	not used – set to L
13	Control bits for standby mode and Current monitor multiplexer			13	V _S undervoltage	chargepump off
12	bit13	bit12	function	12	Temperature shutdown	Temperature warning
	0	0	standby mode	11	OUT6 – HS driver overcurrent	OUT6 – HS driver open load
	0	1	OUT1	10	OUT5 – HS driver overcurrent	OUT5 – HS driver open load
	1	0	OUT2	9	OUT5 – LS driver overcurrent	OUT5 – LS driver open load
	1	1	OUT6	8	OUT4 – HS driver overcurrent	OUT4 – HS driver open load
11	OUT6 – HS driver on/off ⁽¹⁾			7	OUT4 – LS driver overcurrent	OUT4 – LS driver open load
10	OUT5 – HS driver on/off ⁽¹⁾			6	OUT3 – HS driver overcurrent	OUT3 – HS driver open load
9	OUT5 – LS driver on/off ⁽¹⁾			5	OUT3 – LS driver overcurrent	OUT3 – LS driver open load
8	OUT4 – HS driver on/off 5 ⁽¹⁾	test mode bit 8 bit 7		4	OUT2 – HS driver overcurrent	OUT2 – HS driver open load
7	OUT4 – LS driver on/off 5 ⁽¹⁾	1 1 B-driver is active		3	OUT2 – LS driver overcurrent	OUT2 – LS driver open load
6	OUT3 – HS driver on/off 5 ⁽¹⁾	test mode bit 6 bit 5		2	OUT1 – HS driver overcurrent	OUT1 – HS driver open load
5	OUT3 – LS driver on/off 5 ⁽¹⁾	1 1 A-driver is active		1	OUT1 – LS driver overcurrent	OUT1 – LS driver open load
4	OUT2 – HS driver on/off 5 ¹			0	no fault condition ⁽²⁾	
3	OUT2 – LS driver on/off 1			H = on; L = off; HS = highside; LS = lowside		
2	OUT1 – HS driver on/off 1					
1	OUT1 – LS driver on/off 1					
0	Status register select bit L: status register 0; H: status register 1					

(1) If the bits of HS- and LS-driver of the same output stage are high, the internal logic prevents that both drivers of this output stage can be switched on simultaneously in order to avoid a high internal current from V_S to GND.

(2) A logical NOR-combination of all bits 1 to 14 in both status registers. This bit can be polled by the micro-controller without the need of the full SPI communication (see Figure 13). A broken VCC-connection of the L9949 can be detected by the microcontroller, because all 15 bits low or high is not a valid frame.

SPI INTERFACE ELECTRICAL CHARACTERISTICS

$V_S = 8$ to 16 V, $V_{CC} = 4.5$ to 5.5 V, $T_j = -40$ to 150 °C, unless otherwise specified. The voltages are referred to GND and currents are assumed positive, when the current flows into the pin.

Symbol	Parameter	Test Condition	Min.	Typ.	Max.	Unit
Delay time from standby to active mode						
t_{set}	Delay Time	Switching from standby to active mode. Time until output drivers are enabled after CSN going to high.			200	μ s
Inputs: CSN, CLK and DI						
V_{INL}	Input Low Level	$V_{CC} = 5$ V			1.5	V
V_{INH}	Input High Level	$V_{CC} = 5$ V	3.5			V
V_{INHyst}	Input Hysteresis	$V_{CC} = 5$ V	0.5			V
I_{CSNin}	Pull Up Current at input CSN	$V_{CSN} = 3.5$ V	-50	-25	-10	μ A
I_{CLKin}	Pull Down Current at input CLK	$V_{CLK} = 1.5$ V	10	25	50	μ A
I_{DIin}	Pull Down Current at input DI	$V_{DI} = 1.5$ V	10	25	50	μ A
$C_{in}^{(1)}$	Input Capacitance at input CSN or CLK	0 V < V_{CC} < 5.5 V		10	15	pF

DI timing (see Fig. 9)⁽²⁾

t_{CLK}	Clock Period	$V_{CC} = 5$ V	1000			ns
t_{CLKH}	Clock High Time	$V_{CC} = 5$ V	400			ns
t_{CLKL}	Clock Low Time	$V_{CC} = 5$ V	400			ns
$t_{set\ CSN}$	CSN setup time, CSN low before rising edge of CLK	$V_{CC} = 5$ V	400			ns
$t_{set\ CLK}$	CLK setup time, CLK high before rising edge of CSN	$V_{CC} = 5$ V	400			ns
$t_{set\ DI}$	DI setup time	$V_{CC} = 5$ V	200			ns
$t_{hold\ DI}$	DI hold time	$V_{CC} = 5$ V	200			ns
t_{r-in}	Rise Time of Input Signal DI, CLK, CSN	$V_{CC} = 5$ V			100	ns
t_{f-in}	Fall Time of Input Signal DI, CLK, CSN	$V_{CC} = 5$ V			100	ns

DO

V_{DOL}	Output Low Level	$V_{CC} = 5$ V, $I_D = -4$ mA		0.2	0.4	V
V_{DOH}	Output High Level	$V_{CC} = 5$ V, $I_D = -4$ mA	$V_{CC} - 1.3$	$V_{CC} - 1.0$		V
		$V_{CC} = 5$ V, $I_D = -200$ μ A; $T_j = 25$ °C	$V_{CC} - 0.8$			V

SPI INTERFACE ELECTRICAL CHARACTERISTICS (continued)

$V_S = 8$ to 16 V, $V_{CC} = 4.5$ to 5.5 V, $T_j = -40$ to 150 °C, unless otherwise specified. The voltages are referred to GND and currents are assumed positive, when the current flows into the pin.

Symbol	Parameter	Test Condition	Min.	Typ.	Max.	Unit
I_{DOLK}	Tristate Leakage Current	$V_{CSN} = V_{CC}$, $0\text{ V} < V_{DO} < V_{CC}$	-10		10	μA
C_{DO}	Tristate Input Capacitance	$V_{CSN} = V_{CC}$, $0\text{ V} < V_{CC} < 5.5\text{ V}$		10	15	pF

DO timing (see Figg. 10 & 11)

$t_{r DO}$	DO Rise Time	$C_L = 100\text{ pF}$, $I_{load} = -1\text{ mA}$		50	100	ns
$t_{f DO}$	Data Out Fall Time	$C_L = 100\text{ pF}$, $I_{load} = 1\text{ mA}$		50	100	ns
$t_{en DO tri L}$	DO Enable Time from tristate to low level	$C_L = 100\text{ pF}$, $I_{load} = 1\text{ mA}$ pull-up load to V_{CC}		80	250	ns
$t_{en DO L tri}$	DO Disable Time from low level to tristate	$C_L = 100\text{ pF}$, $I_{load} = 4\text{ mA}$ pull-up load to V_{CC}		200	400	ns
$t_{en DO tri H}$	DO Enable Time from tristate to high level	$C_L = 100\text{ pF}$, $I_{load} = -1\text{ mA}$ pull-down load to GND		80	250	ns
$t_{en DO H tri}$	DO Disable Time from high level to tristate	$C_L = 100\text{ pF}$, $I_{load} = -4\text{ mA}$ pull-down load to GND		200	400	ns
$t_{d DO}$	DO Delay Time	$V_{DO} < 0.3 V_{CC}$, $V_{DO} > 0.7 V_{CC}$, $C_L = 100\text{ pF}$		50	250	ns

- (1) Value of input capacity is not measured in production test. Parameter guaranteed by design.
- (2) DI timing parameters tested in production by a passed/failed test:
 $T_j = -40^\circ\text{C}/+25^\circ\text{C}$: SPI communication @2MHz
 $T_j = +125^\circ\text{C}$: SPI communication @1.25MHz

Figure 8. SPI-Interface - Transfer Timing Diagram

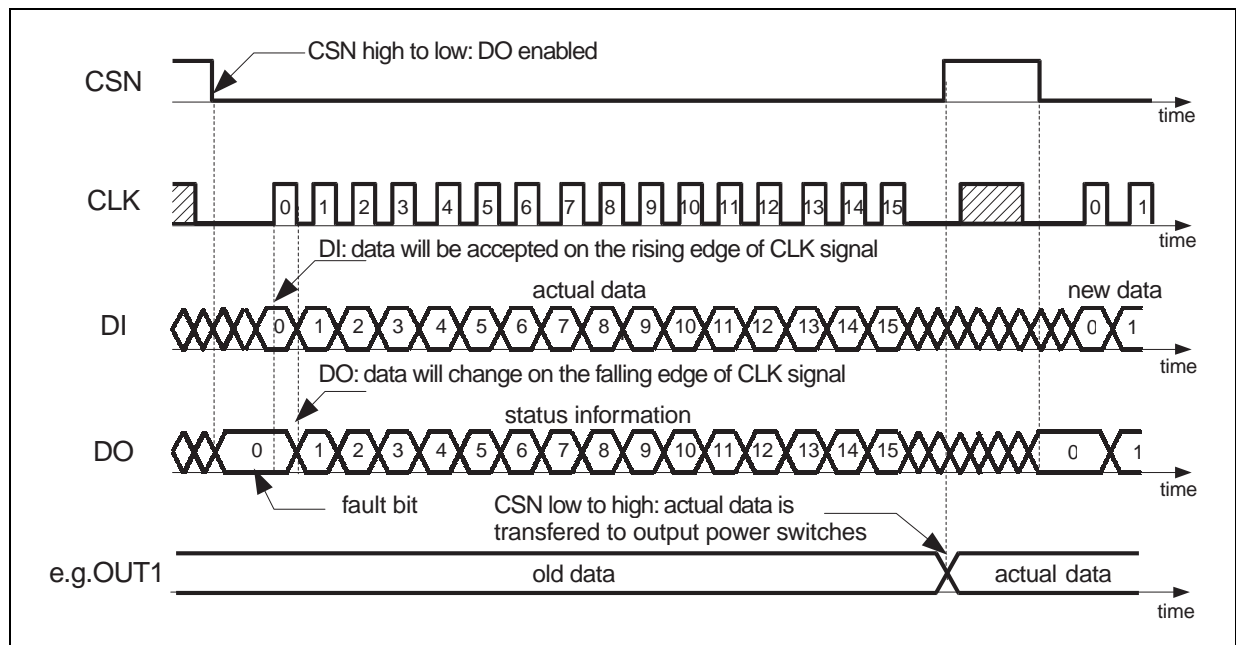

Figure 9. SPI-interface - Input Timing

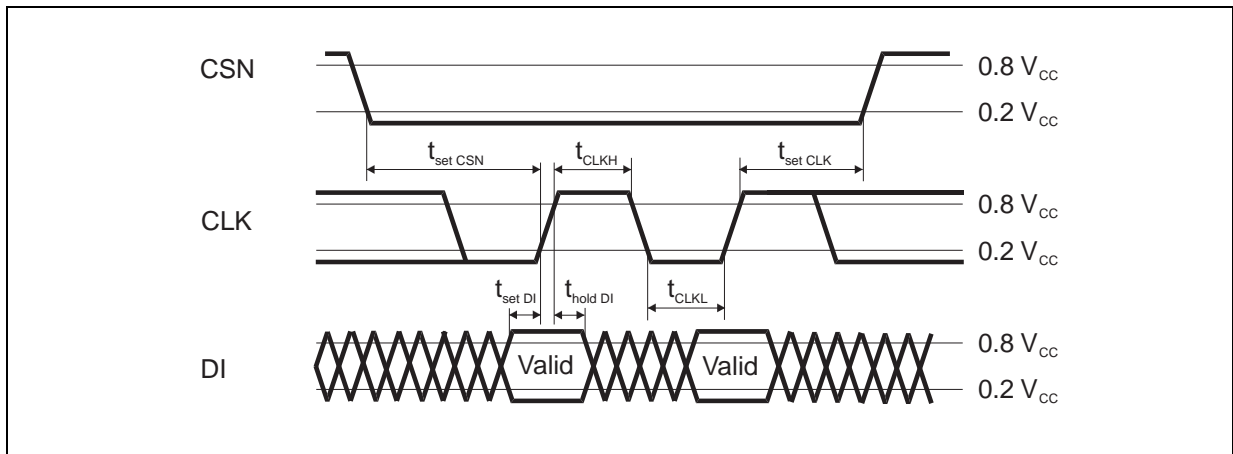

Figure 10. Data Out Valid Data Delay Time and Valid Time

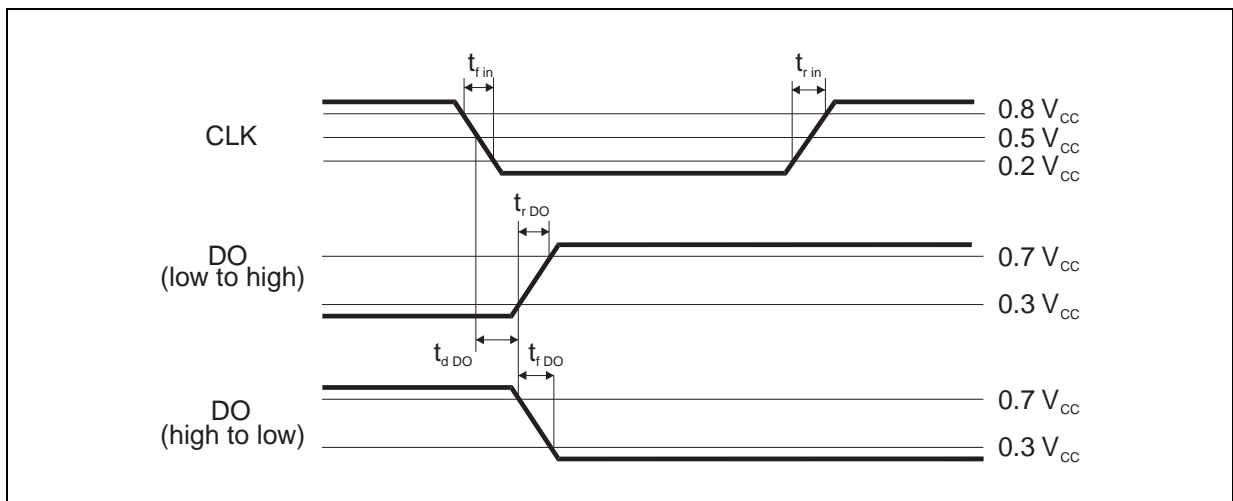

Figure 11. SPI-Interface - Data Out Enable and Disable Time

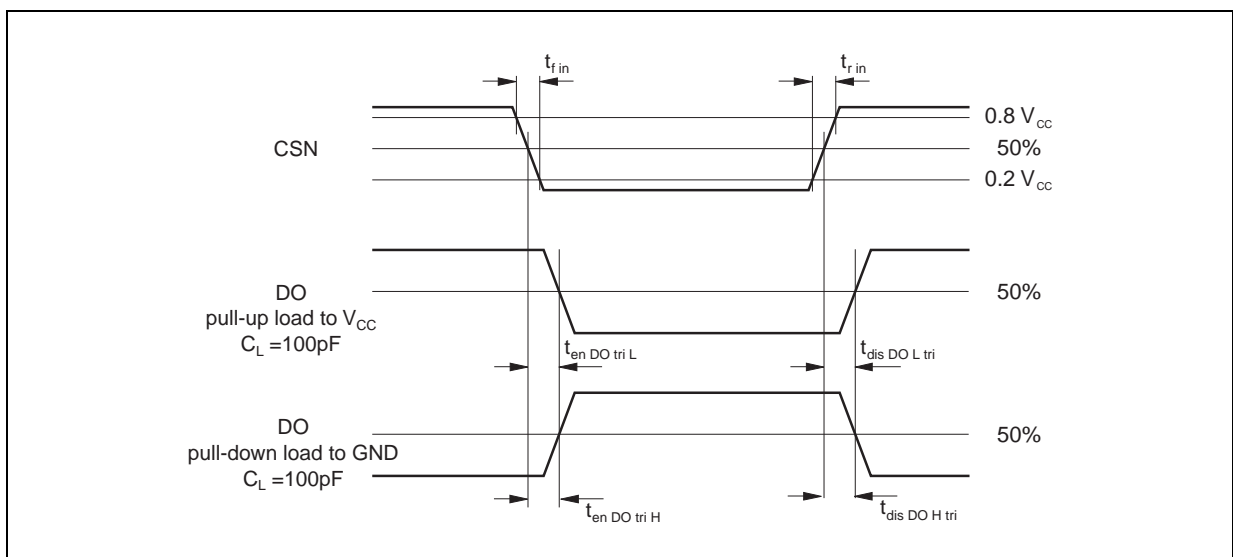

Figure 12. SPI-Interface - Driver Turn On/Off Timing

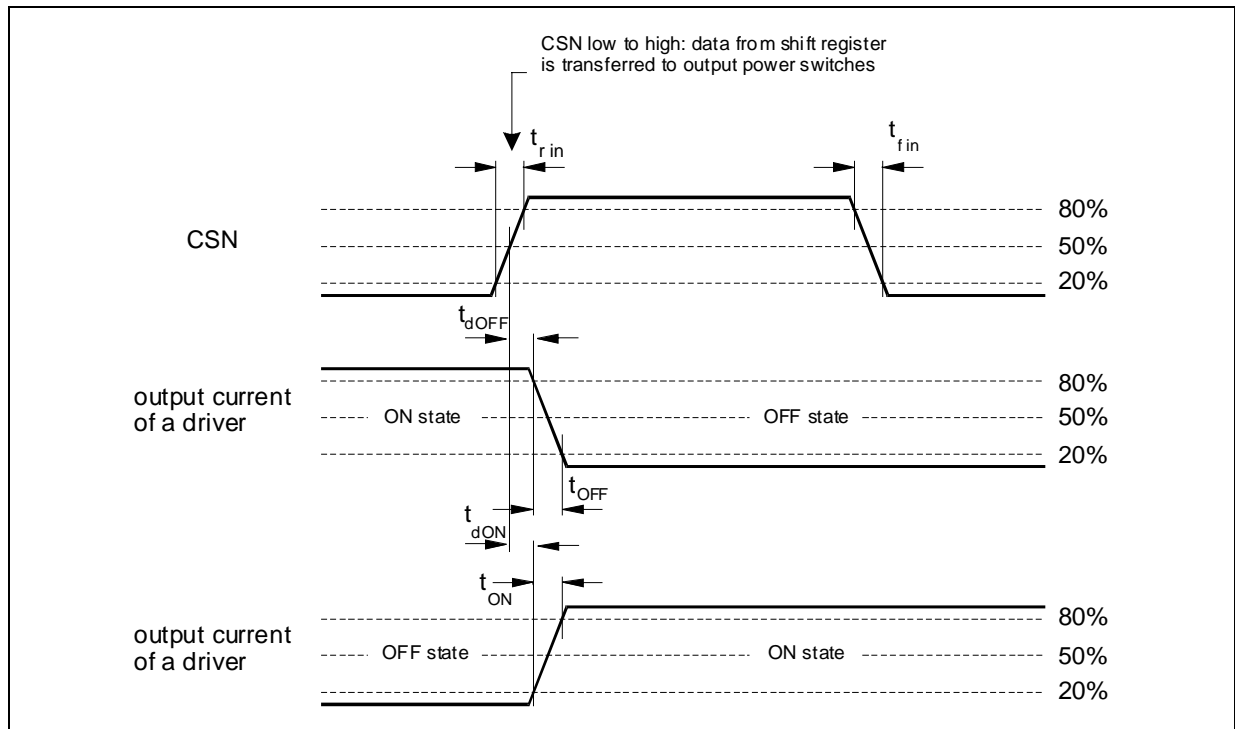
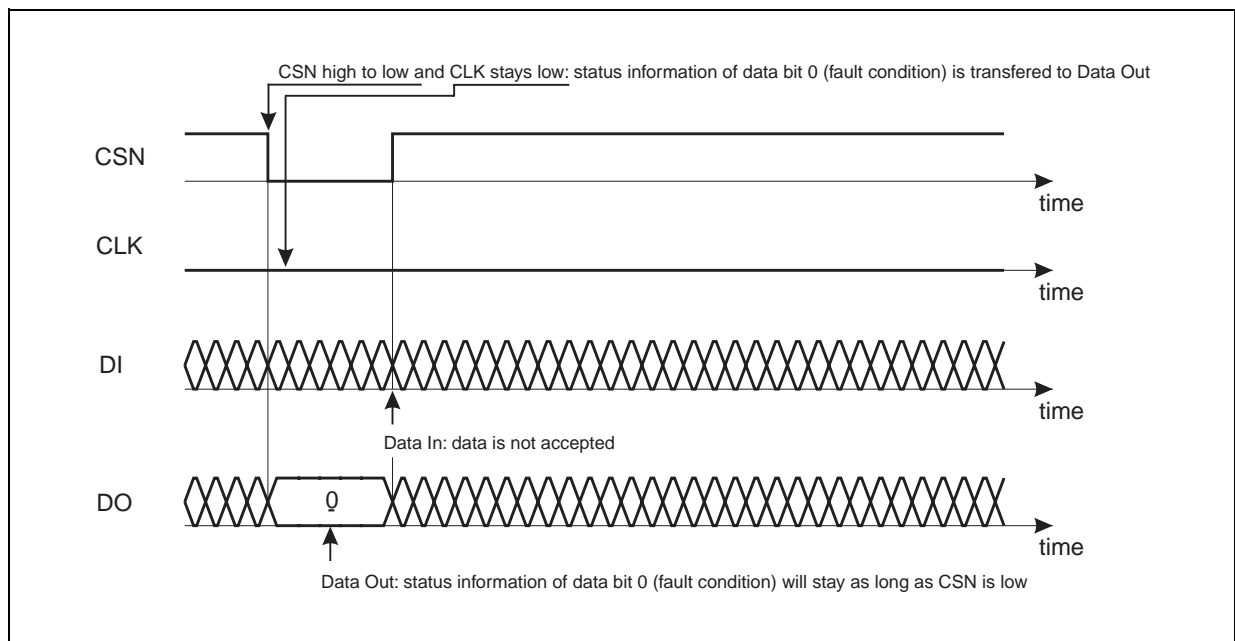

Figure 13. SPI-Interface - Timing of Status Bit 0 (Fault Condition)



DIM.	mm			inch		
	MIN.	TYP.	MAX.	MIN.	TYP.	MAX.
A			3.6			0.142
a1	0.1		0.3	0.004		0.012
a2			3.3			0.130
a3	0		0.1	0.000		0.004
b	0.4		0.53	0.016		0.021
c	0.23		0.32	0.009		0.013
D (1)	15.8		16	0.622		0.630
D1	9.4		9.8	0.370		0.386
E	13.9		14.5	0.547		0.570
e		1.27			0.050	
e3		11.43			0.450	
E1 (1)	10.9		11.1	0.429		0.437
E2			2.9			0.114
E3	5.8		6.2	0.228		0.244
G	0		0.1	0.000		0.004
H	15.5		15.9	0.610		0.626
h			1.1			0.043
L	0.8		1.1	0.031		0.043
N	8° (typ.)					
S	8° (max.)					
T		10			0.394	

(1) "D and E1" do not include mold flash or protusions.
 - Mold flash or protusions shall not exceed 0.15mm (0.006")
 - Critical dimensions: "E", "G" and "a3".

OUTLINE AND MECHANICAL DATA

Weight: 1.9gr

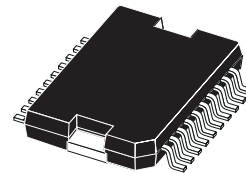

JEDEC MO-166

PowerSO20

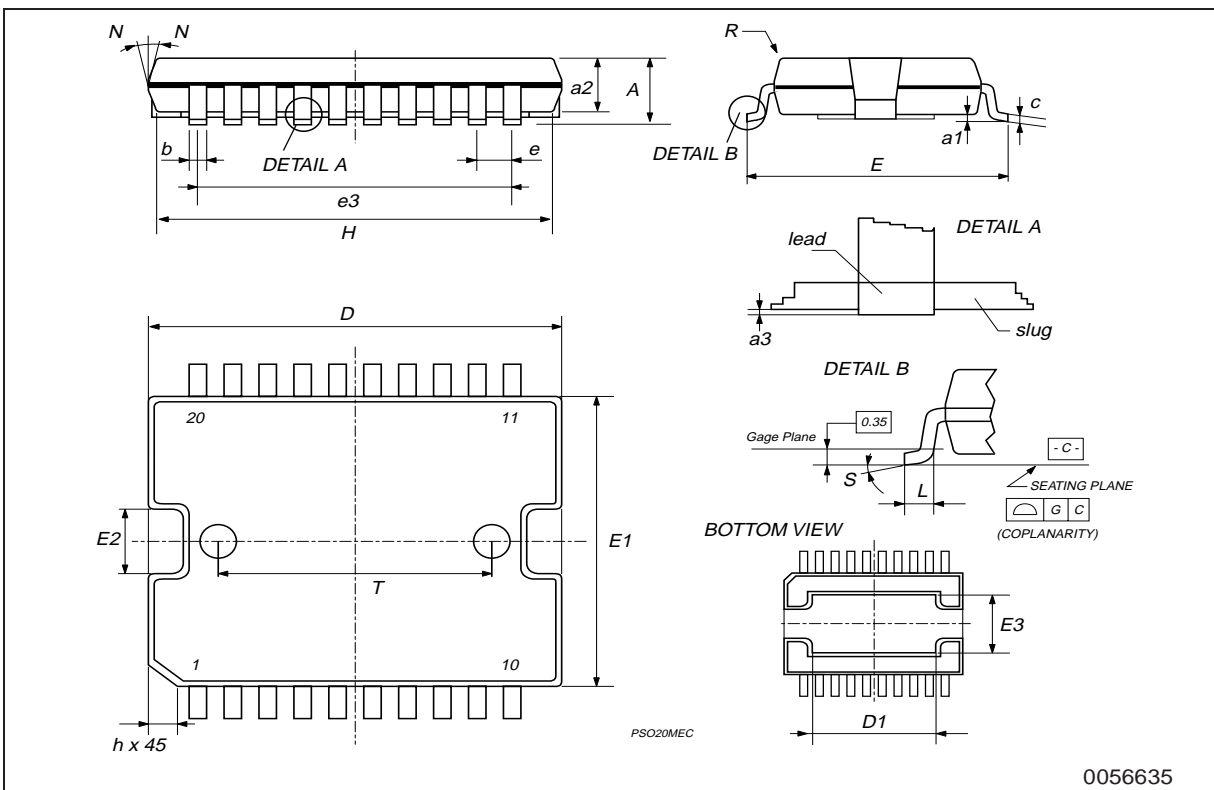

Please Read Carefully:

Information in this document is provided solely in connection with ST products. STMicroelectronics NV and its subsidiaries ("ST") reserve the right to make changes, corrections, modifications or improvements, to this document, and the products and services described herein at any time, without notice.

All ST products are sold pursuant to ST's terms and conditions of sale.

Purchasers are solely responsible for the choice, selection and use of the ST products and services described herein, and ST assumes no liability whatsoever relating to the choice, selection or use of the ST products and services described herein.

No license, express or implied, by estoppel or otherwise, to any intellectual property rights is granted under this document. If any part of this document refers to any third party products or services it shall not be deemed a license grant by ST for the use of such third party products or services, or any intellectual property contained therein or considered as a warranty covering the use in any manner whatsoever of such third party products or services or any intellectual property contained therein.

UNLESS OTHERWISE SET FORTH IN ST'S TERMS AND CONDITIONS OF SALE ST DISCLAIMS ANY EXPRESS OR IMPLIED WARRANTY WITH RESPECT TO THE USE AND/OR SALE OF ST PRODUCTS INCLUDING WITHOUT LIMITATION IMPLIED WARRANTIES OF MERCHANTABILITY, FITNESS FOR A PARTICULAR PURPOSE (AND THEIR EQUIVALENTS UNDER THE LAWS OF ANY JURISDICTION), OR INFRINGEMENT OF ANY PATENT, COPYRIGHT OR OTHER INTELLECTUAL PROPERTY RIGHT.

ST PRODUCTS ARE NOT DESIGNED OR AUTHORIZED FOR USE IN: (A) SAFETY CRITICAL APPLICATIONS SUCH AS LIFE SUPPORTING, ACTIVE IMPLANTED DEVICES OR SYSTEMS WITH PRODUCT FUNCTIONAL SAFETY REQUIREMENTS; (B) AERONAUTIC APPLICATIONS; (C) AUTOMOTIVE APPLICATIONS OR ENVIRONMENTS, AND/OR (D) AEROSPACE APPLICATIONS OR ENVIRONMENTS. WHERE ST PRODUCTS ARE NOT DESIGNED FOR SUCH USE, THE PURCHASER SHALL USE PRODUCTS AT PURCHASER'S SOLE RISK, EVEN IF ST HAS BEEN INFORMED IN WRITING OF SUCH USAGE, UNLESS A PRODUCT IS EXPRESSLY DESIGNATED BY ST AS BEING INTENDED FOR "AUTOMOTIVE, AUTOMOTIVE SAFETY OR MEDICAL" INDUSTRY DOMAINS ACCORDING TO ST PRODUCT DESIGN SPECIFICATIONS. PRODUCTS FORMALLY ESCC, QML OR JAN QUALIFIED ARE DEEMED SUITABLE FOR USE IN AEROSPACE BY THE CORRESPONDING GOVERNMENTAL AGENCY.

Resale of ST products with provisions different from the statements and/or technical features set forth in this document shall immediately void any warranty granted by ST for the ST product or service described herein and shall not create or extend in any manner whatsoever, any liability of ST.

ST and the ST logo are trademarks or registered trademarks of ST in various countries.

Information in this document supersedes and replaces all information previously supplied.

The ST logo is a registered trademark of STMicroelectronics. All other names are the property of their respective owners.

© 2013 STMicroelectronics - All rights reserved

STMicroelectronics group of companies

Australia - Belgium - Brazil - Canada - China - Czech Republic - Finland - France - Germany - Hong Kong - India - Israel - Italy - Japan - Malaysia - Malta - Morocco - Philippines - Singapore - Spain - Sweden - Switzerland - United Kingdom - United States of America

www.st.com