



SANYO Semiconductors

# DATA SHEET

An ON Semiconductor Company

## LA72730 — Monolithic Linear IC For TV Audio/Video Switch

### Overview

The LA72730 is an Audio/Video Switch for TV.

### Functions

- Audio : Possible to Change 4 Channel×2, ALC OUTPUT, 4dB Amplifier MONITOR OUTPUT
- Video : Possible to Change 4 Channel, 6dB Amplifier
- Control : I<sup>2</sup>C (Slave address : 92h)

### Specifications

#### Maximum Ratings at Ta = 25°C

Parameter	Symbol	Conditions	Ratings	Unit
Maximum supply voltage	V <sub>CC</sub> max	Pin 8	7.0	V
Allowable power dissipation	Pd max	Ta ≤ 70°C	300	mW
Operating temperature	Topr		-20 to +70	°C
Storage temperature	Tstg		-55 to +150	°C

#### Recommended Operating Conditions at Ta = 25°C

Parameter	Symbol	Conditions	Ratings	Unit
Recommended operating voltage	V <sub>CC</sub>	Pin 8	5.0	V
Operating voltage range	V <sub>CC</sub> op	Pin 8	4.5 to 5.5	V

■ Any and all SANYO Semiconductor Co.,Ltd. products described or contained herein are, with regard to "standard application", intended for the use as general electronics equipment (home appliances, AV equipment, communication device, office equipment, industrial equipment etc.). The products mentioned herein shall not be intended for use for any "special application" (medical equipment whose purpose is to sustain life, aerospace instrument, nuclear control device, burning appliances, transportation machine, traffic signal system, safety equipment etc.) that shall require extremely high level of reliability and can directly threaten human lives in case of failure or malfunction of the product or may cause harm to human bodies, nor shall they grant any guarantee thereof. If you should intend to use our products for applications outside the standard applications of our customer who is considering such use and/or outside the scope of our intended standard applications, please consult with us prior to the intended use. If there is no consultation or inquiry before the intended use, our customer shall be solely responsible for the use.

■ Specifications of any and all SANYO Semiconductor Co.,Ltd. products described or contained herein stipulate the performance, characteristics, and functions of the described products in the independent state, and are not guarantees of the performance, characteristics, and functions of the described products as mounted in the customer's products or equipment. To verify symptoms and states that cannot be evaluated in an independent device, the customer should always evaluate and test devices mounted in the customer's products or equipment.

**SANYO Semiconductor Co., Ltd.**

[www.semiconductor-sanyo.com/network](http://www.semiconductor-sanyo.com/network)

# LA72730

**Electrical Characteristics** at Ta = 25°C, V<sub>DD</sub> = 5.0V

Parameter	Symbol	Conditions	Ratings			Unit
			min	typ	max	
Current dissipation	I <sub>CC</sub>	V <sub>CC</sub> = 5V, No signal	15.2	18	20.8	mA
<b>Audio block</b>						
Audio input DC voltage	INa	No signal pin 1, 2, 3, 4, 5, 6, 23, 24 DC voltage	2.2	2.4	2.6	V
Audio output DC voltage	Oa	No signal pin 19, 20 DC voltage	2.2	2.4	2.6	V
Audio channel bandwidth	Fa	Input : 1kHz/20kHz, -6dBV : Pin 19, 20 output	-2	0	+2	dB
Audio voltage gain (Audio-out)	Aa1	f = 1kHz, V <sub>IN</sub> = -6dBV, Pin 19, 20 output	-0.3	0.0	+0.3	dB
Audio voltage gain (Monitor-out)	Aa2	f = 1kHz, V <sub>IN</sub> = -6dBV, Pin 12, 16 output	3.5	4.0	4.5	dB
Audio input dynamic range (Audio-out)	Da1	f = 1kHz, THD = ≤1% Pin 19, 20 output	-3.0	-1.0		dBV
Audio input dynamic range (Monitor-out)	Da2	f = 1kHz, THD = ≤1% Pin 13, 16 output	-5.0	-3.0		dBV
Audio channel PSRR	PSa	V <sub>CC</sub> = 5V+1Vp-p, SINE WAVE (50Hz)	35	50		dB
Audio channel input impedance	Ria		80	100	120	kΩ
Audio channel output impedance	Roa		150	200	250	Ω
Audio channel crosstalk	CTa	f = 1kHz	65	80		dB
Audio channel S/N	SNa	Filter = DIN/AUDIO	70	85		dB
Audio channel THD	THDa	f = 1kHz, V <sub>IN</sub> = -6dBV		0.15	0.3	%
ALC Detect level-1	ALC1		-10.5	-9	-7.5	dBV
ALC Detect level-2	ALC2		-15.5	-14	-12.5	dBV
ALC Detect level-3	ALC3		-13.5	-12	-10.5	dBV
ALC Detect level-4	ALC4		-19.5	-18	-16.5	dBV
<b>Video block</b>						
Video input DC voltage	INv		1.44	1.6	1.76	V
Video output DC voltage	Ov		1.26	1.4	1.54	V
Video channel bandwidth	Fv	-3dB frequency	10			MHz
Video signal voltage gain	Av	f = 500kHz, V <sub>IN</sub> = 1Vp-p	5.0	6.0	7.0	dB
Video input dynamic range	Dv	f = 100kHz, THD ≤ 1%	2.0	2.5		Vp-p
Video channel PSRR	PSv	V <sub>CC</sub> = 5V+1Vp-p, SINE WAVE (50Hz)	35	50		dB
Video channel input impedance	Riv		8.0	10	12.0	kΩ
Video channel output impedance	Rov		30	40	50	Ω
Video channel crosstalk	CTv	f = 3.58MHz, V <sub>IN</sub> = 1Vp-p	45	60		dB
Video channel noise	SNv	Bandwidth 10MHz	55	60		dB

## Package Dimensions

unit : mm (typ)

3067B

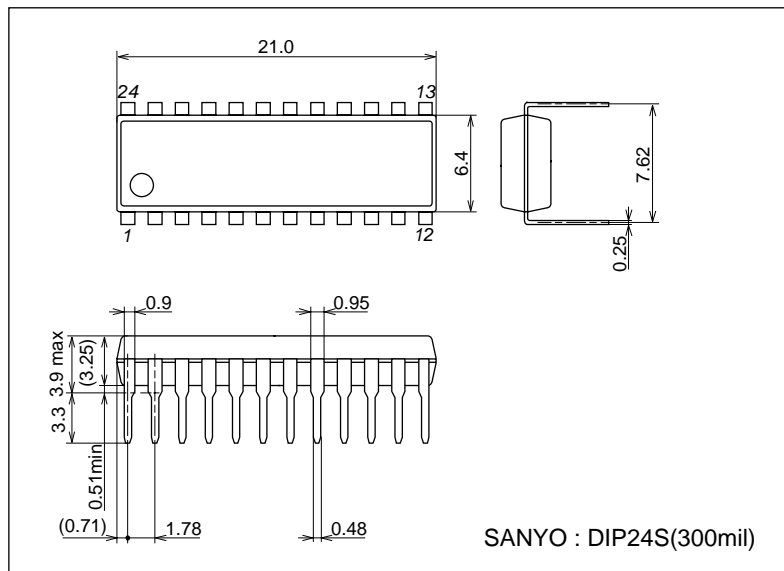

# LA72730

## Block Diagram

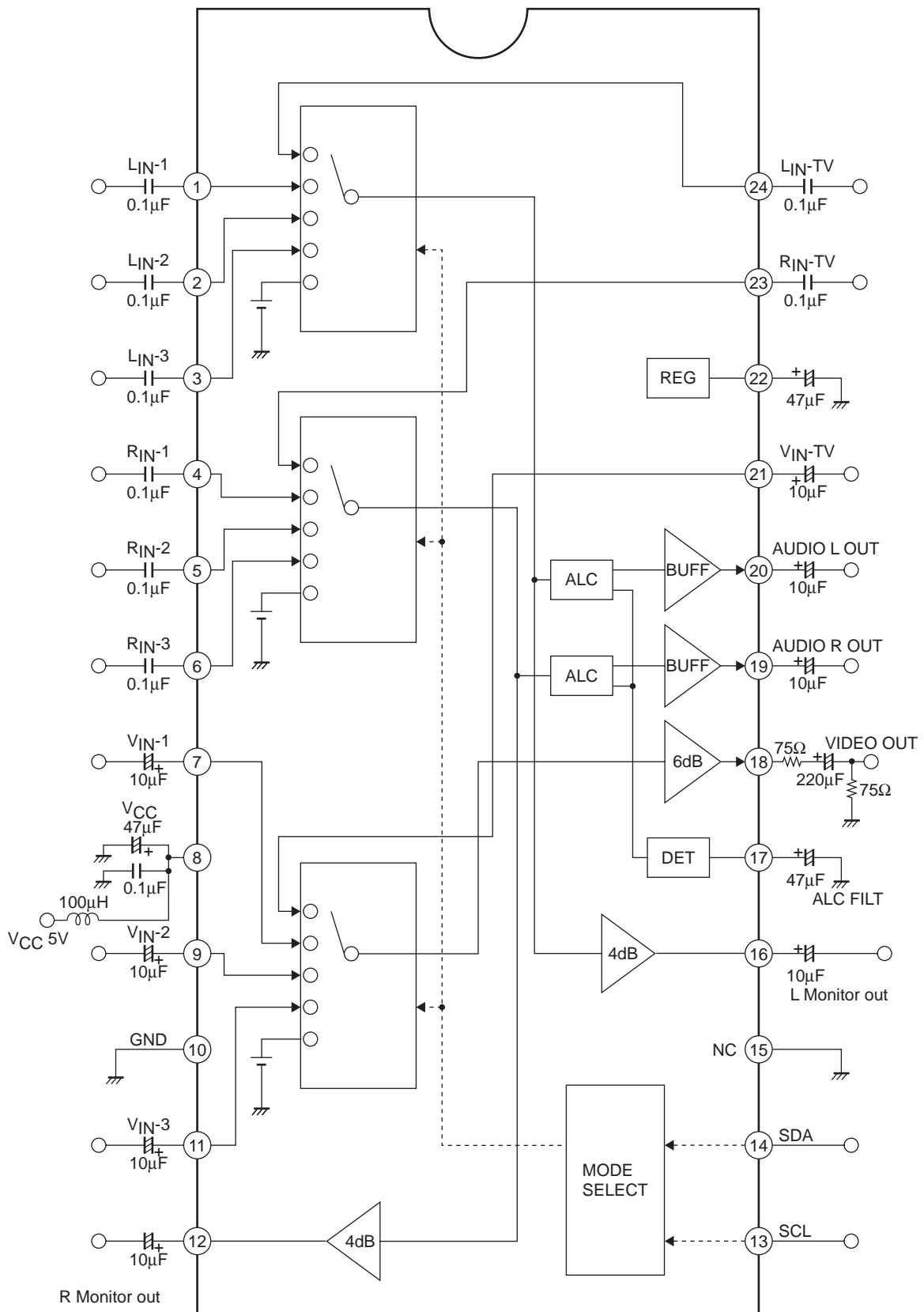

# LA72730

## I<sup>2</sup>C Bit Pattern

D8	D7	D6	D5	D4	D3	D2	D1	Condition
*						0	0	AV IN-TV
						0	1	AV IN-1
						1	0	AV IN-2
						1	1	AV IN-3
*					0			Norma
					1			Mute
			0	0				ALC Level-1 (-9dBV)
			0	1				ALC Level-2 (-14dBV)
*			1	0				ALC Level-3 (-12dBV)
			1	1				ALC Level-4 (-18dBV)
*		0						ALC-ON
		1						ALC-OFF
	0							Prohibit
*	1							Fix
*	0							Fix
	1							Prohibit

“\*” : Shows initial condition.

Slave address : 92h (1001 0010)

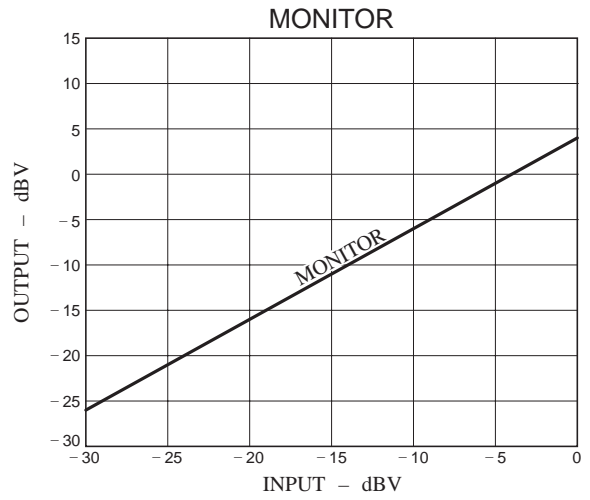
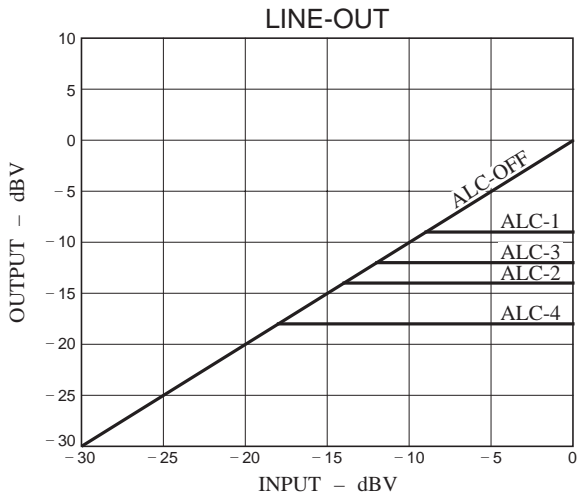

Test Circuit

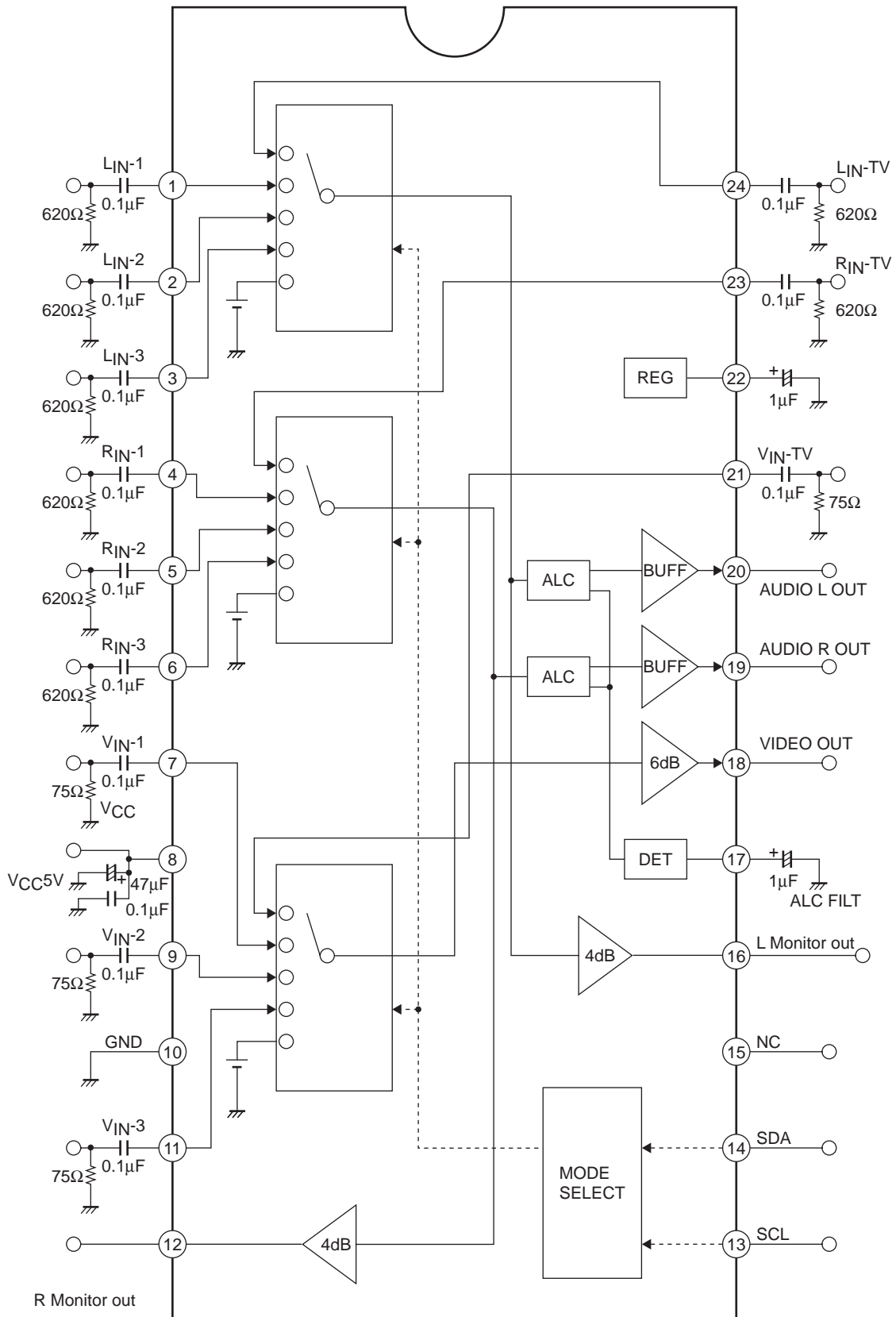

# LA72730

## Pin Functions

Pin No.	Pin Name	Function	DC : voltage	Equivalent Circuit
			AC : level	
1 2 3 4 5 6 23 24	PIA_L1 PIA_L2 PIA_L3 PIA_R1 PIA_R2 PIA_R3 PIA_RTV PIA_LTV	Audio input	DC : 2.4V	
7 9 11 21	PIV_1 PIV_2 PIV_3 PIV_TV	Video input	DC : 1.6V	
8	V <sub>CC</sub>			
10	GND			
12 16	POMONITR POMONITL	Monitor output	DC : 2.4V	
13	PISCL	Serial clock input		
14	PISDA	Serial data input		
17	POALCFIL	ALC detect filter		

Continued on next page

# LA72730

Continued from preceding page.

Pin No.	Pin Name	Function	DC : voltage	Equivalent Circuit
			AC : level	
18	POVIDEO	Video output	DC : 1.4V	
19 20	POALCR POALCL	Audio output	DC : 2.4V	
22	PCREG	Reference voltage	DC : 2.4V	

## I<sup>2</sup>C BUS serial interface specification

### (1) Data Transfer Manual

This IC adopts control method (I<sup>2</sup>C-BUS) with serial data, and controlled by two terminals which called SCL (serial clock) and SDA (serial data). At first, set up <sup>\*1</sup> the condition of starting data transfer, and after that, input 8 bit data to SDA terminal with synchronized SCL terminal clock. The order of transferring is first, MSB (the Most Scale of Bit), and save the order. The 9th bit takes ACK (Acknowledge) period, during SCL terminal takes “H”, this IC pull down the SDA terminal. After transferred the necessary data, two terminals lead to set up and of <sup>\*2</sup> data transfer stop condition, thus the transfer comes to close.

- \*1 Defined by SDA fall down SCL during ‘H’ period.
- \*2 Defined by SDA rise up SCL during ‘H’ period.

### (2) Transfer Data Format

After transfer start condition, transfers slave address (92h : 1001 0010 ) to SDA terminal, control data, then, stop condition (See figure 1).  
 Slave address is made up of 7bits, <sup>\*3</sup> 8th bit shows the direction of transferring data, but this IC does not have READ mode, so that this bit fix to “L”.  
 Data works with all of bit, transfer the stop condition before stop 8bit transfer, and to stop transfer, it will be canceled the transfer dates.

- \*3 It is called R/W bit.

Fig.1 DATA STRUCTURE

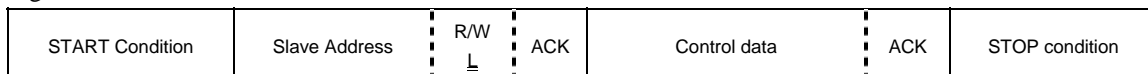

### (3) Initialize

This IC is initialized for circuit protection. Initial condition is shown on bitmap.

Reference

Parameter	Symbol	min	max	unit
LOW level input voltage	$V_{IL}$	-0.5	1.5	V
HIGH level input voltage	$V_{IH}$	2.5	5.5	V
LOW level output current	$I_{OL}$		3.0	mA
SCL clock frequency	$f_{SCL}$	0	100	kHz
Set-up time for a repeated START condition	$t_{SU:STA}$	4.7		$\mu$ s
Hold time START condition. After this period, the first clock pulse is generated	$t_{HD:STA}$	4.0		$\mu$ s
LOW period of the SCL clock	$t_{LOW}$	4.7		$\mu$ s
Rise time of both SDA and SDL signals	$t_R$	0	1.0	$\mu$ s
HIGH period of the SCL clock	$t_{HIGH}$	4.0		$\mu$ s
Fall time of both SDA and SDL signals	$t_F$	0	1.0	$\mu$ s
Data hold time	$t_{HD:DAT}$	0		$\mu$ s
Data set-up time	$t_{SU:DAT}$	250		ns
Set-up time for STOP condition	$t_{SU:STO}$	4.0		$\mu$ s
BUS free time between a STOP and START condition	$t_{BUF}$	4.7		$\mu$ s

Definition of timing

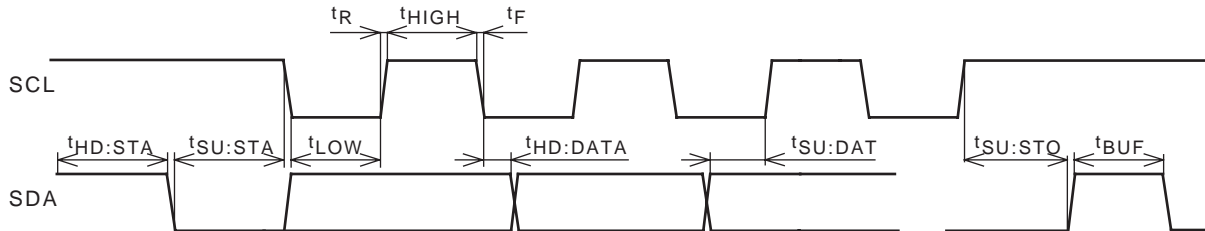

- SANYO Semiconductor Co.,Ltd. assumes no responsibility for equipment failures that result from using products at values that exceed, even momentarily, rated values (such as maximum ratings, operating condition ranges, or other parameters) listed in products specifications of any and all SANYO Semiconductor Co.,Ltd. products described or contained herein.
- SANYO Semiconductor Co.,Ltd. strives to supply high-quality high-reliability products, however, any and all semiconductor products fail or malfunction with some probability. It is possible that these probabilistic failures or malfunction could give rise to accidents or events that could endanger human lives, trouble that could give rise to smoke or fire, or accidents that could cause damage to other property. When designing equipment, adopt safety measures so that these kinds of accidents or events cannot occur. Such measures include but are not limited to protective circuits and error prevention circuits for safe design, redundant design, and structural design.
- In the event that any or all SANYO Semiconductor Co.,Ltd. products described or contained herein are controlled under any of applicable local export control laws and regulations, such products may require the export license from the authorities concerned in accordance with the above law.
- No part of this publication may be reproduced or transmitted in any form or by any means, electronic or mechanical, including photocopying and recording, or any information storage or retrieval system, or otherwise, without the prior written consent of SANYO Semiconductor Co.,Ltd.
- Any and all information described or contained herein are subject to change without notice due to product/technology improvement, etc. When designing equipment, refer to the "Delivery Specification" for the SANYO Semiconductor Co.,Ltd. product that you intend to use.
- Information (including circuit diagrams and circuit parameters) herein is for example only; it is not guaranteed for volume production.
- Upon using the technical information or products described herein, neither warranty nor license shall be granted with regard to intellectual property rights or any other rights of SANYO Semiconductor Co.,Ltd. or any third party. SANYO Semiconductor Co.,Ltd. shall not be liable for any claim or suits with regard to a third party's intellectual property rights which has resulted from the use of the technical information and products mentioned above.

This catalog provides information as of February, 2010. Specifications and information herein are subject to change without notice.