



SANYO Semiconductors DATA SHEET

LB11972V — Monolithic Digital IC 3-Phase Sensorless Motor Driver for Fan Motor Driver for Refrigerator

Overview

The LB11972V is a 3-phase full-wave current linear sensorless motor driver.
It is optimal for refrigerator fan motor drive.

Functions

- Three-phase sensor-less motor driver
- Current linear drive
- Built-in current limiting circuit
- Built-in output stage saturation preventive circuit
- With coil counter-electromotive FG output
- Built-in thermal shutdown circuit
- Built-in beat lock preventive circuit

Specifications

Absolute Maximum Ratings at $T_a = 25^\circ\text{C}$

Parameter	Symbol	Conditions	Ratings	Unit
Supply voltage	V_{CC} max		15.0	V
Output application voltage	V_O max		15.0	V
Input application voltage	V_I max		-0.3 to $V_{CC}+0.3$	V
Output current	I_O max		1.0	A
Internal allowable loss	Pd max1	Independent IC	0.5	W
	Pd max2	Mounted on a specified board.*	1.0	W
Operating temperature	T_{opr}		-30 to +85	$^\circ\text{C}$
Storage temperature	T_{stg}		-55 to +150	$^\circ\text{C}$

* Specified board (114.3×76.1×1.6mm : Glass epoxy)

Operating Range at $T_a = 25^\circ\text{C}$

Parameter	Symbol	Conditions	Ratings	Unit
Supply voltage	V_{CC}		7 to 13.8	V

- Any and all SANYO products described or contained herein do not have specifications that can handle applications that require extremely high levels of reliability, such as life-support systems, aircraft's control systems, or other applications whose failure can be reasonably expected to result in serious physical and/or material damage. Consult with your SANYO representative nearest you before using any SANYO products described or contained herein in such applications.
- SANYO assumes no responsibility for equipment failures that result from using products at values that exceed, even momentarily, rated values (such as maximum ratings, operating condition ranges, or other parameters) listed in products specifications of any and all SANYO products described or contained herein.

LB11972V

Electrical Characteristics at $T_a = 25^\circ\text{C}$, $V_{CC} = 12\text{V}$

Parameter	Symbol	Conditions	Ratings			Unit
			min	typ	max	
Circuit current	I_{CC}			20	30	mA
Output saturation voltage 1	V_{OSAT1}	$I_O = 0.4\text{A}$, Source+Sink		1.4	2.0	V
Output saturation voltage 2	V_{OSAT2}	$I_O = 0.8\text{A}$, Source+Sink, $R_F = 0\Omega$		1.8	2.6	V
MCOM pin common-phase input voltage range	VIC		0		$V_{CC}-2$	V
PCOUT output current 1	IPCOU	Source side		-90		μA
PCOUT output current 2	IPCOD	Sink side		90		μA
VCONIN input current	IVCOIN	VCOIN = 5V		0.1	0.2	μA
VCO minimum frequency	FVCOMIN	VCOIN = open		400		Hz
VCO maximum frequency	FVCOMAX	VCOIN = 5V		18.5		kHz
C1, C2 source current ratio	RSOURCE	1- ($IC1SOURCE/IC2SOURCE$)	-12		+12	%
C1, C2 sink current ratio	RSINK	1- ($IC1SINK/IC2SINK$)	-12		+12	%
C1 source, sink current ratio	RC1	$IC1SOURCE/IC1SINK$		50		%
C2 source, sink current ratio	RC2	$IC2SOURCE/IC2SINK$		50		%
Counter-electromotive FG output ON voltage	V_{OL}	IFGO = 1mA			0.4	V
Thermal shutdown operation temperature	TTSD	Design target value*	150	180	210	$^\circ\text{C}$
Thermal shutdown hysteresis	$\Delta TTSD$	Design target value*		15		$^\circ\text{C}$
Current limiter operation voltage	VRFILIM	$R_L = 1\text{k}\Omega$, $R_F = 100\Omega$	0.38	0.44	0.50	V

Note* : These items are design target values and are not tested.

Package Dimensions

unit : mm

3315

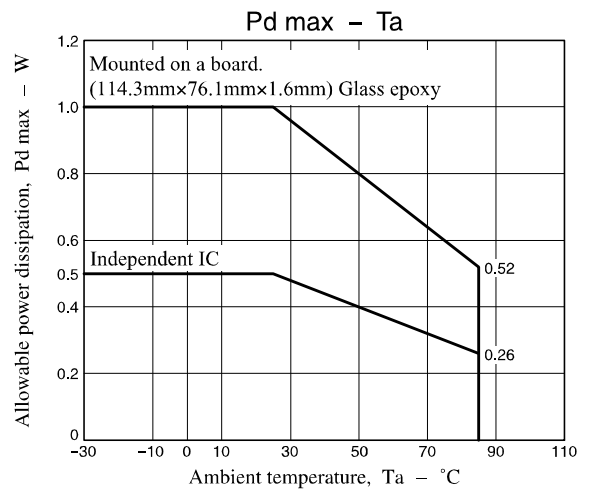
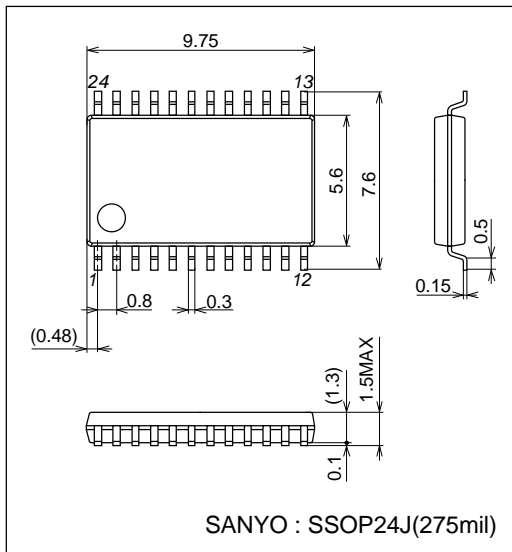

LB11972V

Block Diagram (The external constant may vary depending on the motor.)

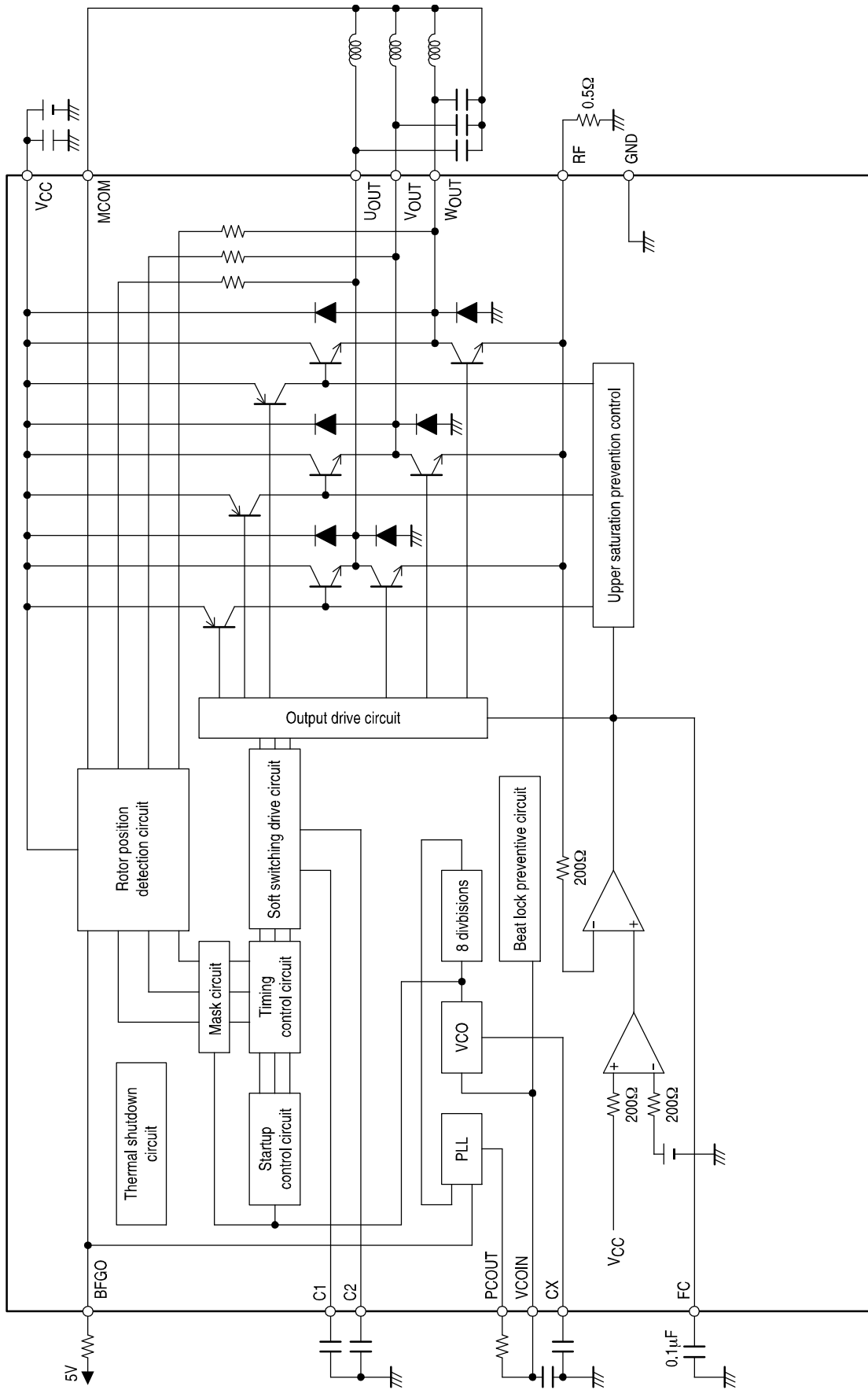

LB11972V

Pin Assignment

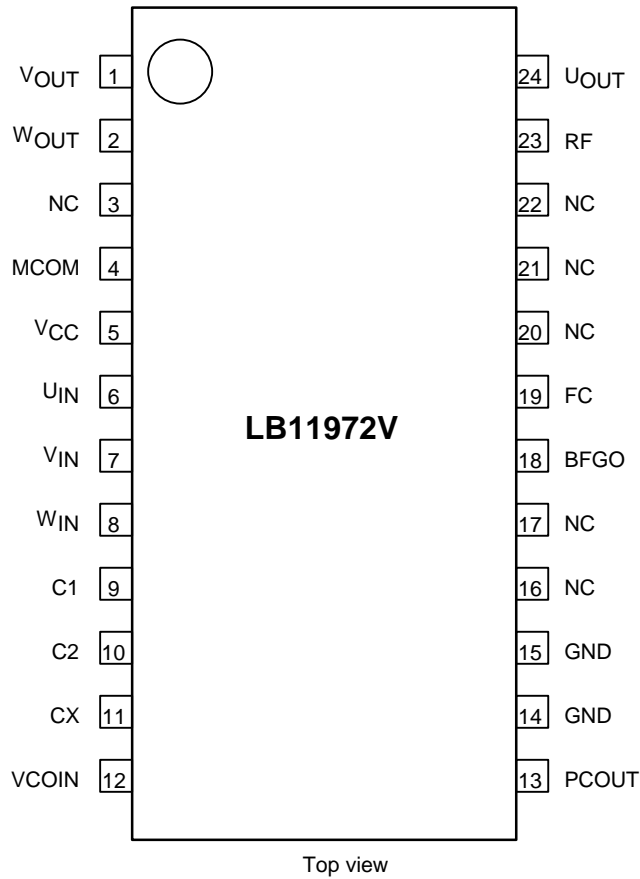

Pin Description

Pin No.	Pin Symbol	Pin Voltage	Equivalent Circuit Diagram	Pin Description
24	UOUT			Drum motor driver output pin
1	VOUT			
2	WOUT			
23	RF			Minimum potential of drum motor driver output transistor. Constant current control is made by detecting this voltage. The current limiter operates by detecting this potential, too.
5	VCC	7 to 13.8V		Power pin

Continued on next page.

LB11972V

Continued from preceding page.

Pin No.	Pin Symbol	Pin Voltage	Equivalent Circuit Diagram	Pin Description
4	MCOM			<p>Motor coil middle input pin. Coil voltage waveform is detected with reference to this voltage.</p> <p>Coil waveform detection comparator input pin Connected to the output of each phase via built-in resistor of 10kΩ.</p>
6	U _{IN}			
7	V _{IN}			
8	W _{IN}			
9	C1			<p>Pin connected to the capacitor to generate triangular wave. This triangular wave is used for soft switching of the coil output waveform.</p>
10	C2			
11	CX			<p>Value of the capacitor connected to this pin and GND in the VCO circuit, determining the operation frequency range and minimum operation frequency.</p>
12	VCOIN			<p>VCO circuit voltage input pin. Enters the PCOUT pin voltage after CR filtering</p>

Continued on next page.

LB11972V

Continued from preceding page.

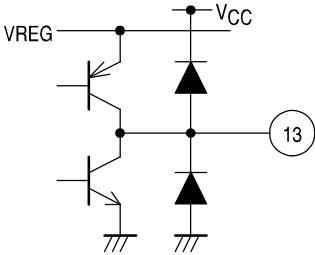
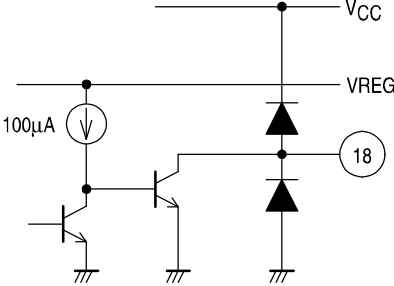
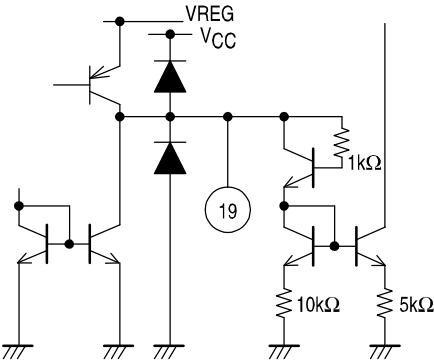
Pin No.	Pin Symbol	Pin Voltage	Equivalent Circuit Diagram	Pin Description
13	PCOUT			VCO circuit PLL output pin
14	GND			All GNDs other than the output transistor
15				
18	BFGO			Motor couter-electromotive voltage detection FG output (single phase only)
19	FC			Frequency characteristics compensation pin Prevents oscillation of the closed loop of current control system by inserting the capacitor between this pin and GND.

LB11972V

Sample Application Circuit (Reference)

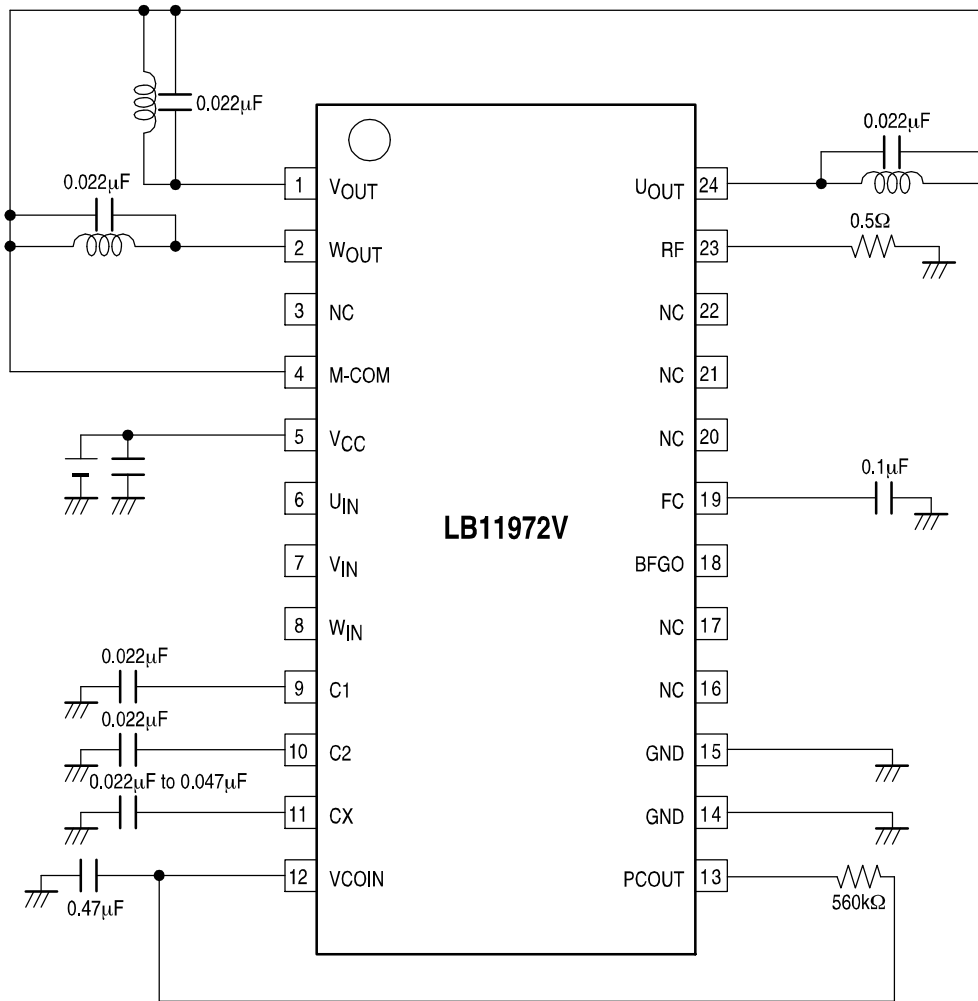

- Note 1) The constant values for capacitors, etc. are given here for reference after review by Sanyo. When reviewing this IC, adjust the value according to the motor used.
- Note 2) If the output is not oscillated with the motor used, the capacitor provided at both ends of output coil are not necessary.
- Note 3) Pins Nos. 6 to 8 (U_{IN} , V_{IN} , W_{IN}) are not to be used by the customer. Be sure to keep these pins independent and open because they are connected inside IC.
- Note 4) NC pins (Nos. 3, 16, 17, 20, 21, and 22) are not connected inside IC and thus can be used as relay pins.

- Specifications of any and all SANYO products described or contained herein stipulate the performance, characteristics, and functions of the described products in the independent state, and are not guarantees of the performance, characteristics, and functions of the described products as mounted in the customer's products or equipment. To verify symptoms and states that cannot be evaluated in an independent device, the customer should always evaluate and test devices mounted in the customer's products or equipment.
- SANYO Electric Co., Ltd. strives to supply high-quality high-reliability products. However, any and all semiconductor products fail with some probability. It is possible that these probabilistic failures could give rise to accidents or events that could endanger human lives, that could give rise to smoke or fire, or that could cause damage to other property. When designing equipment, adopt safety measures so that these kinds of accidents or events cannot occur. Such measures include but are not limited to protective circuits and error prevention circuits for safe design, redundant design, and structural design.
- In the event that any or all SANYO products (including technical data, services) described or contained herein are controlled under any of applicable local export control laws and regulations, such products must not be exported without obtaining the export license from the authorities concerned in accordance with the above law.
- No part of this publication may be reproduced or transmitted in any form or by any means, electronic or mechanical, including photocopying and recording, or any information storage or retrieval system, of otherwise, without the prior written permission of SANYO Electric Co., Ltd.
- Any and all information described or contained herein are subject to change without notice due to product/technology improvement, etc. When designing equipment, refer to the "Delivery Specification" for the SANYO product that you intend to use.
- Information (including circuit diagrams and circuit parameters) herein is for example only; it is not guaranteed for volume production. SANYO believes information herein is accurate and reliable, but no guarantees are made or implied regarding its use or any infringements of intellectual property rights or other rights of third parties.

This catalog provides information as of October, 2005. Specifications and information herein are subject to change without notice.
