



LB1673M

3-Phase Brushless, Sensorless Motor Driver

Applications

Rotational control of brushless motors for use in audio applications such as headphone stereos, micro-cassette recorders, mini-cassette recorders.

Function and Features

- Brushless, sensorless motor drive (3-phase half-wave drive).
- Bidirectional motor drive.
- On-chip speed control function (V servo type).
- On-chip reference voltage.
- On-chip one comparator (PNP input, NPN open collector output).

Package Dimensions

unit:mm

3112-MFP24S

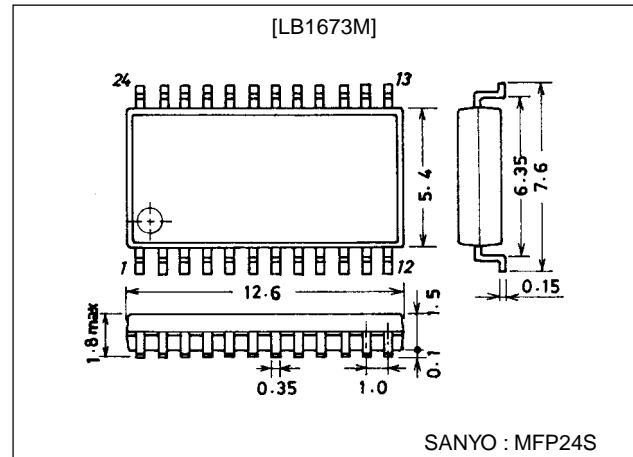

Specifications

Absolute Maximum Ratings at $T_a = 25^\circ\text{C}$

Parameter	Symbol	Conditions	Ratings	Unit
Maximum supply voltage	$V_{CC \text{ max}}$		5	V
Output Transistor Breakdown voltage	$V_{SUS \text{ max}}$		10	V
Output current	I_M		1	A
Allowable power dissipation	$P_d \text{ max}$		0.58	W
Operating temperature	T_{opr}		0 to +80	$^\circ\text{C}$
Storage temperature	T_{stg}		-40 to +125	$^\circ\text{C}$

Allowable Operating Conditions at $T_a = 25^\circ\text{C}$

Parameter	Symbol	Conditions	Ratings	Unit
Supply voltage	V_{CC}		1.0 to 3.5	V

■ Any and all SANYO products described or contained herein do not have specifications that can handle applications that require extremely high levels of reliability, such as life-support systems, aircraft's control systems, or other applications whose failure can be reasonably expected to result in serious physical and/or material damage. Consult with your SANYO representative nearest you before using any SANYO products described or contained herein in such applications.

■ SANYO assumes no responsibility for equipment failures that result from using products at values that exceed, even momentarily, rated values (such as maximum ratings, operating condition ranges, or other parameters) listed in products specifications of any and all SANYO products described or contained herein.

SANYO Electric Co., Ltd. Semiconductor Business Headquarters

TOKYO OFFICE Tokyo Bldg., 1-10, 1 Chome, Ueno, Taito-ku, TOKYO, 110-8534 JAPAN

83198HA (KT)/5280TA No.3473-1/4

LB1673M

Electrical Characteristics at Ta = 25°C

Parameter	Symbol	Conditions	Ratings			Unit
			min	typ	max	
Supply current 1	$I_{CC(L)}$	START pin low		0	10	mA
Supply current 2	$I_{CC(H)}$	START pin high		4.8	10	μ A
Reference voltage	Vref		0.49	0.52	0.55	V
Voltage characteristic of reference voltage	$\frac{\Delta V_{ref}}{V_{ref}/\Delta V_{CC}}$	$V_{CC}=1$ to 3.5V		0.3	1.0	%/V
Load characterisric of reference voltage	$\frac{\Delta V_{ref}}{\Delta I_{ref}}$	$I_{ref}=0$ to -60μ A		-0.03		mV/ μ A
Temperature characteristic of reference voltage	$\frac{\Delta V_{ref}}{V_{ref}}/\Delta T_a$	$T_a=0$ to $+80^\circ$ C		0		%/ $^\circ$ C
Speed signal detection accuracy	Vsp	$V_{IN}=500$ mV	135	145	155	mV
Speed signal correlation error			-5		5	%
Voltage characteristic of speed signal	$\frac{\Delta V_{sp}}{V_{sp}}/\Delta V_{CC}$	$V_{CC}=1$ to 3.5V		0.2	1.0	%/V
Temperature characteristic of speed signal	$\frac{\Delta V_{sp}}{V_{sp}}/\Delta T_a$	$T_a=0$ to $+60^\circ$ C		0		%/ $^\circ$ C
Current detection accuracy	V_{RI}	$V_{IN1}=0.3$ V, $V_{IN2}=1$ V	50	65	80	mV
Current detection ratio	K_I	$V_{IN2}=1$ to 1.3V	0.14	0.17	0.25	
Pin OSC flow-out current	I_{OSC}	Measured as pin OSC is 0.4V	2.6	3.8	5.0	μ A
Starting pulse width	T_{OSC}	$C_S=0.47\mu$ F		60		ms
COM pull-in current	V_{COM} \ominus	Short V_{CC} with COM	20	30	40	μ A
Output saturation voltage	Vsat	$V_{CC}=1$ V, $I_m=0.2$ A		0.09	0.25	V
Logic input high-level voltage	V_H		0.9			V
Logic input low-level voltage	V_L				0.3	V
Comparator offset voltage	V_{OFF}		-10		+10	mV
Comparator output current	I_{OFF}	$V_{CC}=1$ V, $OUT1=V_{CC}$	100			μ A

Equivalent Circuit Block Diagram

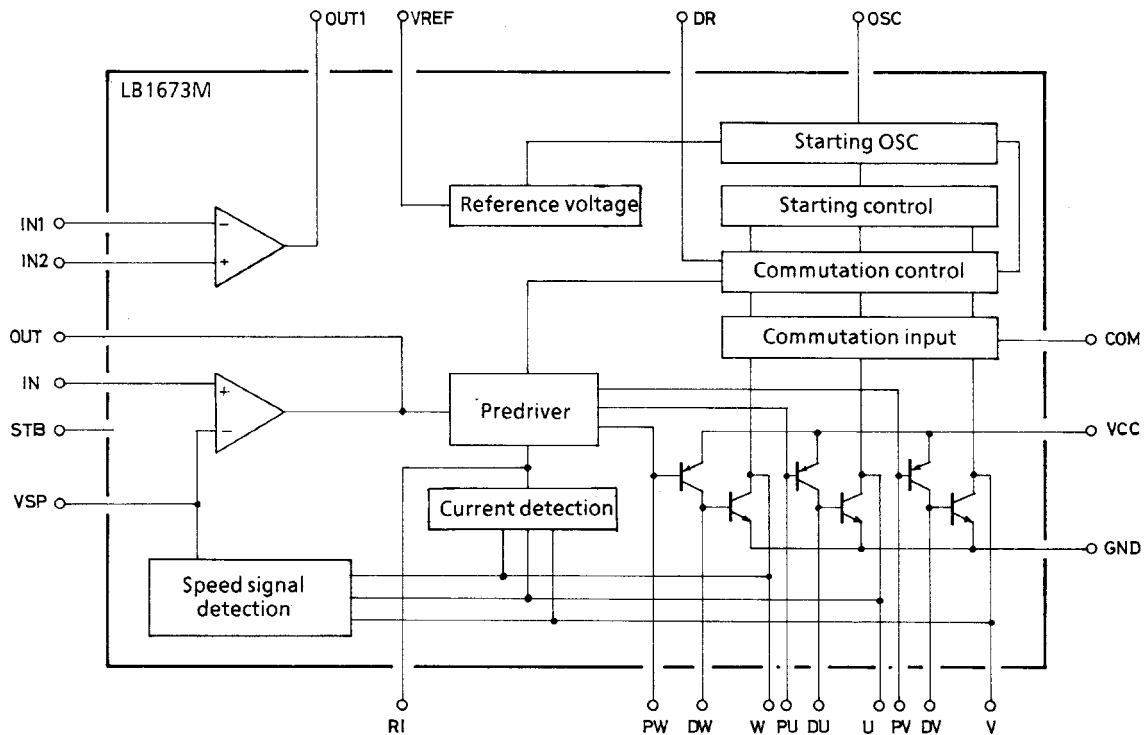

LB1673M

Sample Peripheral Circuit

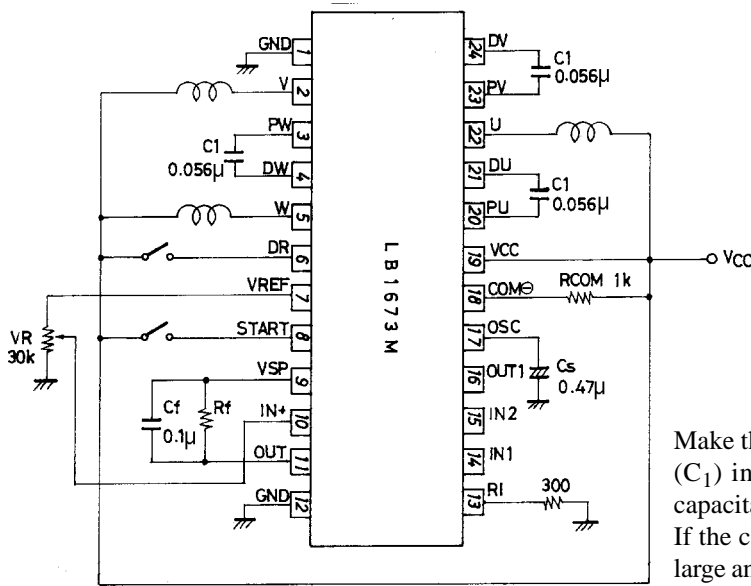

Unit (resistance : Ω, capacitance : F)

Pin Assignment

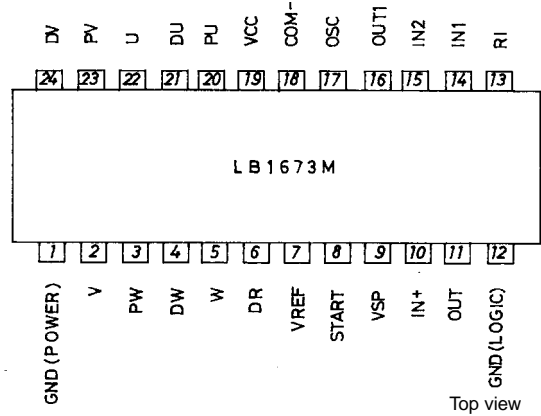

Make the capacitance of the oscillation blocking capacitor (C_1) in the output section as small as possible and the capacitance of C_2 as large as possible.

If the capacitance of the capacitor in the output section is large and the capacitance of C_S is small, the starting voltage may rise at low temperatures. In 3V-use, reverse rotation of a motor would not be well, consider the resistance of R_{com} .

Pin Description

Pin No.	Pin name	Description
1	GND	GND pin for the whole circuit.
2	V	V phase output pin
3	PW	W phase output drive transistor base
4	DW	W phase output transistor base
5	W	W phase output pin
6	DR	Pin for selecting the direction of rotation (H : forward)
7	Vref	Reference voltage (0.5V)
8	START	High active
9	Vsp	Speed signal (induced voltage) detection
10	IN \oplus	Speed signal error amp reference input
11	OUT	Speed signal error amp output. The motor current is fed back.
12	GND	GND pin for logic circuit.
13	RI	Pin for detecting the motor current
14	IN1	\ominus input of internal comparator (PNP base input)
15	IN2	\oplus input of internal comparator (PNP base input)
16	OUT1	Output of internal comparator (NPN open collector)
17	OSC	Pin for setting the starting pulse width
18	COM \ominus	Pin for providing a supplementary function for the current control circuit at the time of start or selection of direction of rotation
19	V _{CC}	Power supply pin
20	PU	U phase output drive transistor base
21	DU	U phase output transistor base
22	U	U phase output pin
23	PV	V phase output drive transistor base
24	DV	V phase output transistor base

- Specifications of any and all SANYO products described or contained herein stipulate the performance, characteristics, and functions of the described products in the independent state, and are not guarantees of the performance, characteristics, and functions of the described products as mounted in the customer's products or equipment. To verify symptoms and states that cannot be evaluated in an independent device, the customer should always evaluate and test devices mounted in the customer's products or equipment.
- SANYO Electric Co., Ltd. strives to supply high-quality high-reliability products. However, any and all semiconductor products fail with some probability. It is possible that these probabilistic failures could give rise to accidents or events that could endanger human lives, that could give rise to smoke or fire, or that could cause damage to other property. When designing equipment, adopt safety measures so that these kinds of accidents or events cannot occur. Such measures include but are not limited to protective circuits and error prevention circuits for safe design, redundant design, and structural design.
- In the event that any and all SANYO products described or contained herein fall under strategic products (including services) controlled under the Foreign Exchange and Foreign Trade Control Law of Japan, such products must not be exported without obtaining export license from the Ministry of International Trade and Industry in accordance with the above law.
- No part of this publication may be reproduced or transmitted in any form or by any means, electronic or mechanical, including photocopying and recording, or any information storage or retrieval system, or otherwise, without the prior written permission of SANYO Electric Co., Ltd.
- Any and all information described or contained herein are subject to change without notice due to product/technology improvement, etc. When designing equipment, refer to the "Delivery Specification" for the SANYO product that you intend to use.
- Information (including circuit diagrams and circuit parameters) herein is for example only ; it is not guaranteed for volume production. SANYO believes information herein is accurate and reliable, but no guarantees are made or implied regarding its use or any infringements of intellectual property rights or other rights of third parties.

This catalog provides information as of August, 1998. Specifications and information herein are subject to change without notice.