



LB1988N

Three-Phase Sensorless Motor Driver + Loading Motor Driver

Overview

The LB1988N is a sensorless motor driver that includes an on-chip loading motor driver as well. It is optimal for VCR drum motor drive.

Functions and Features

- Soft switching drive
- Does not require Hall-effect sensors
- Does not require FG sensors
- PG amplifier
- Thermal shutdown circuit
- Current limiter circuit
- Loading motor driver

Package Dimensions

unit: mm

3196-DIP30SD

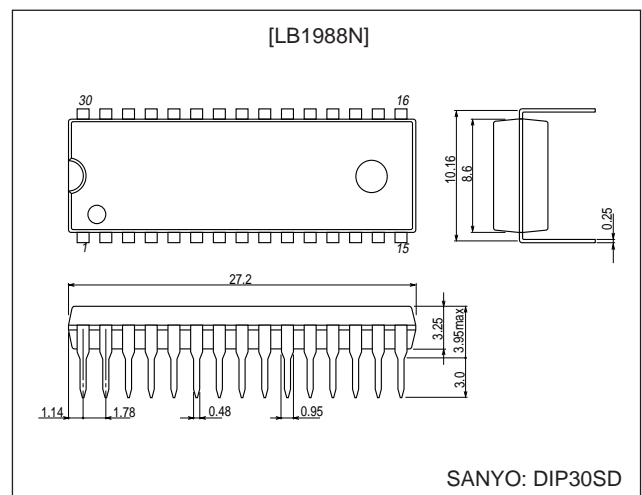

Specifications

Absolute Maximum Ratings at $T_a = 25^\circ\text{C}$

Parameter	Symbol	Conditions	Ratings	Unit
Maximum supply voltage 1	V_{CCmax}		14.5	V
Maximum supply voltage 2	V_{CCLmax}		14.5	V
Maximum supply voltage 3	V_{REGmax}		7.0	V
Maximum applied output voltage	V_{omax}		14.5	V
Maximum applied input voltage	V_{I1max}		-0.3 to $V_{REG} + 0.3$	V
Maximum cylinder current	I_{omax}		1.0	A
Maximum loading current	$I_{omax} (AVE)$		0.4	A
	$I_{omax} (peak)$		1.2	A
Allowable power dissipation	P_{dmax}	When mounted on the specified printed circuit board*	2.8	W
Operating temperature	T_{opr}		-20 to +75	$^\circ\text{C}$
Storage temperature	T_{stg}		-55 to +150	$^\circ\text{C}$

Note: * Specified printed circuit board: 114.3 × 76.1 × 1.6 mm³, glass epoxy

■ Any and all SANYO products described or contained herein do not have specifications that can handle applications that require extremely high levels of reliability, such as life-support systems, aircraft's control systems, or other applications whose failure can be reasonably expected to result in serious physical and/or material damage. Consult with your SANYO representative nearest you before using any SANYO products described or contained herein in such applications.

■ SANYO assumes no responsibility for equipment failures that result from using products at values that exceed, even momentarily, rated values (such as maximum ratings, operating condition ranges, or other parameters) listed in products specifications of any and all SANYO products described or contained herein.

SANYO Electric Co.,Ltd. Semiconductor Company

TOKYO OFFICE Tokyo Bldg., 1-10, 1 Chome, Ueno, Taito-ku, TOKYO, 110-8534 JAPAN

LB1988N

Allowable Operating Ranges at Ta = 25°C

Parameter	Symbol	Conditions	Ratings	Unit
Supply voltage 1	V _{CC}		8 to 13.8	V
Supply voltage 2	V _{CCL}		8 to 13.8	V
Supply voltage 3	V _{REG}		4 to 6	V

Electrical Characteristics at Ta = 25°C, V_{CC} = V_{CCL} = 12 V, V_{REG} = 5 V

Parameter	Symbol	Conditions	Ratings			Unit
			min	typ	max	
Supply voltage 1	I _{CC}	VC = 0 V, XIN = YIN = 0 V		6.5	10	mA
Supply voltage 2	I _{CCL}	VC = 0 V, XIN = YIN = 0 V			1	mA
Supply voltage 3	I _{REG}	VC = 0 V, XIN = YIN = 0 V		6.5	10	mA
Output saturation voltage 1	V _{OSAT1}	I _O = 0.4 A, source + sink		1.4	2.0	V
Output saturation voltage 2	V _{OSAT2}	I _O = 0.8 A, source + sink		1.8	2.6	V
MC pin common-mode input voltage range	V _{IC}		0		V _{CC} - 2	V
VC pin input bias current	I _{VC}	VC = 0 V	-2	-1		μA
Control start voltage	V _{THVC}	V _{RF} = 10 mV	2.4	2.5	2.6	V
Closed loop control gain	GMVC	RF = 0.5 Ω	0.75	0.95	1.15	A/V
PCOUT output current 1	I _{PCOU}	Source side		-90		μA
PCOUT output current 2	I _{PCOD}	Sink side		90		μA
VCOIN input current	I _{VCOIN}	VCOIN = 5 V		0.1	0.2	μA
Minimum VCO frequency	f _{VCOMIN}	CX = 0.022 μF, VCOIN = open		400		Hz
Maximum VCO frequency	f _{VCOMAX}	CX = 0.022 μF, VCOIN = 5 V		18.5		kHz
C1/C2 source current ratio	RSOURCE	IC1SOURCE/IC2SOURCE	-12		+12	%
C1/C2 sink current ratio	RSINK	IC1SINK/IC2SINK	-12		+12	%
C1 source/sink current ratio	RC1	IC1SOURCE/IC1SINK	-35		+15	%
C2 source/sink current ratio	RC2	IC2SOURCE/IC2SINK	-35		+15	%
Thermal shutdown operating temperature	TTSD	*	150	180	210	°C
Thermal shutdown hysteresis	ΔTTSD	*		15		°C

FG and PG Amplifier Block at Ta = 25°C, V_{CC} = V_{CCL} = 12 V, V_{REG} = 5 V

Parameter	Symbol	Conditions	Ratings			Unit
			min	typ	max	
Back EMF FG						
Output on voltage	V _{OL}				0.4	V
Output off voltage	V _{OH}		4.5			V
PG amplifier						
Input offset voltage	V _{IO}		-8		+8	mV
Input bias current	I _{BIN}		-250			nA
Common-mode input voltage range	V _{ICOM}	*	1		3.5	V
Open-loop gain	G _{VPG}	f = 1 kHz		55		dB
Output on voltage	V _{OL}				0.4	V
Output off voltage	V _{OH}		4.5			V
Schmitt amplifier hysteresis	V _{SHIS}		70	93	115	mV

Note: Items marked with an asterisk are design target values and are not tested.

Continued on next page.

LB1988N

Continued from preceding page.

Loading Block at $T_a = 25^\circ\text{C}$, $V_{CC} = V_{CCL} = 12\text{ V}$, $V_{REG} = 5\text{ V}$

Parameter	Symbol	Conditions	Ratings			Unit
			min	typ	max	
Input voltage	1 (HIGH)	V_{IN1}	3.5		5	V
	2 (LOW)	V_{IN2}	0		0.8	V
Input current	I_{IN}	Sink, $V_{IN} = 3.5\text{ V}$		30	50	μA
Input hysteresis	ΔVT			0.7		V
Saturation voltage	VSAT U-1	$V_{ref} = V_S$, between the output and V_S $I_O = 0.2\text{ A}$, CW/CCW mode		1.5	2.1	V
	VSAT L-1	$V_{ref} = V_S$, between the output and V_S $I_O = 0.2\text{ A}$, CW/CCW mode		0.2	0.3	V
	VSAT U-1'	$V_{ref} = V_S$, between the output and V_S $I_O = 0.4\text{ A}$, CW/CCW mode		1.6	2.2	V
	VSAT L-1'	$V_{ref} = V_S$, between the output and V_S $I_O = 0.4\text{ A}$, CW/CCW mode		0.3	0.5	V
Upper side residual voltage	VSATU-1"	$V_{ref} = 8\text{ V}$, between the output and ground $I_O = 0.2\text{ A}$, CW/CCW mode	7.2	8.0	8.8	V
	VSATL-1"	$V_{ref} = 8\text{ V}$, between the output and ground $I_O = 0.4\text{ A}$, CW/CCW mode	7.2	8.0	8.8	V
Output transistor leakage current	up	ILU			50	μA
	down	ILL			50	μA
Diode forward voltage	up	VFU	$I_F = 0.4\text{ A}$	1.3		V
	down	VFL	$I_F = 0.4\text{ A}$	1.0		
Control supply current	I_{ref}		-5	-2		μA

LB1988N

Loading Motor Truth Table

Input		Output		Mode
XIN	YIN	XOUT	YOUT	
L	L	Off	Off	Standby
H	L	H	L	Forward
L	H	L	H	Reverse
H	H	L	L	Brake

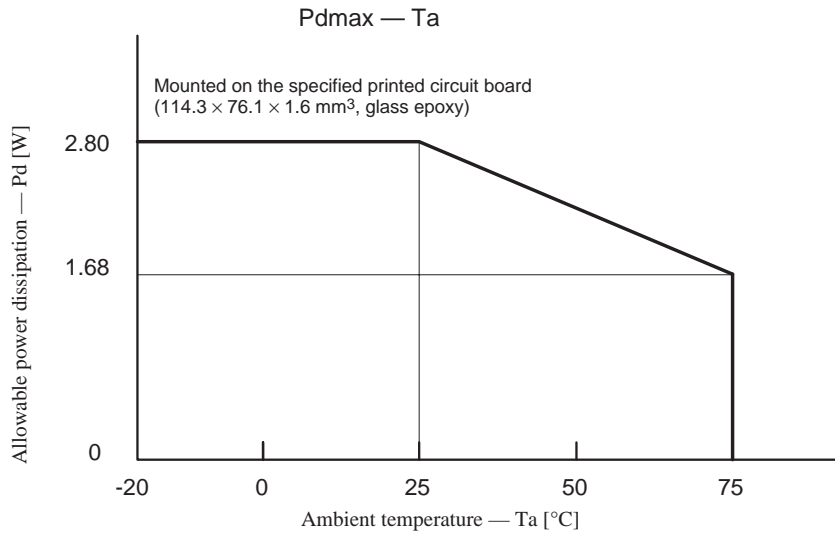

Pin Assignment

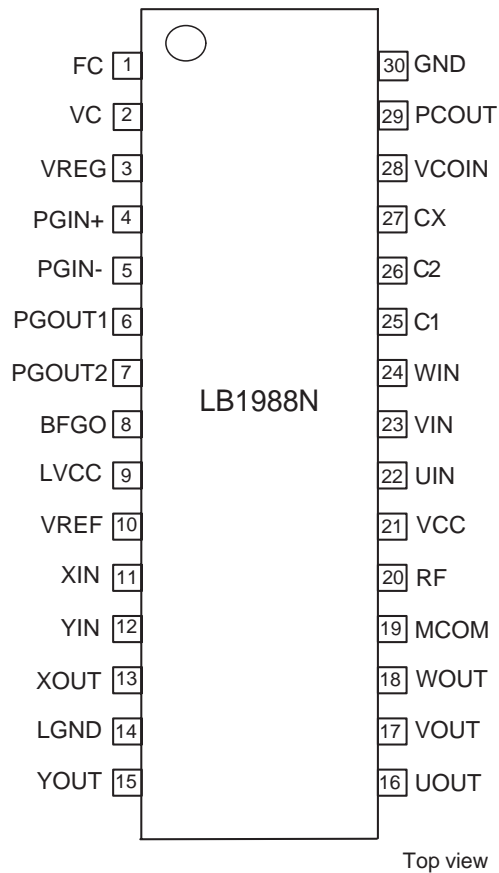

Block Diagram (Note that the values of the external components will vary with the motor actually used.)

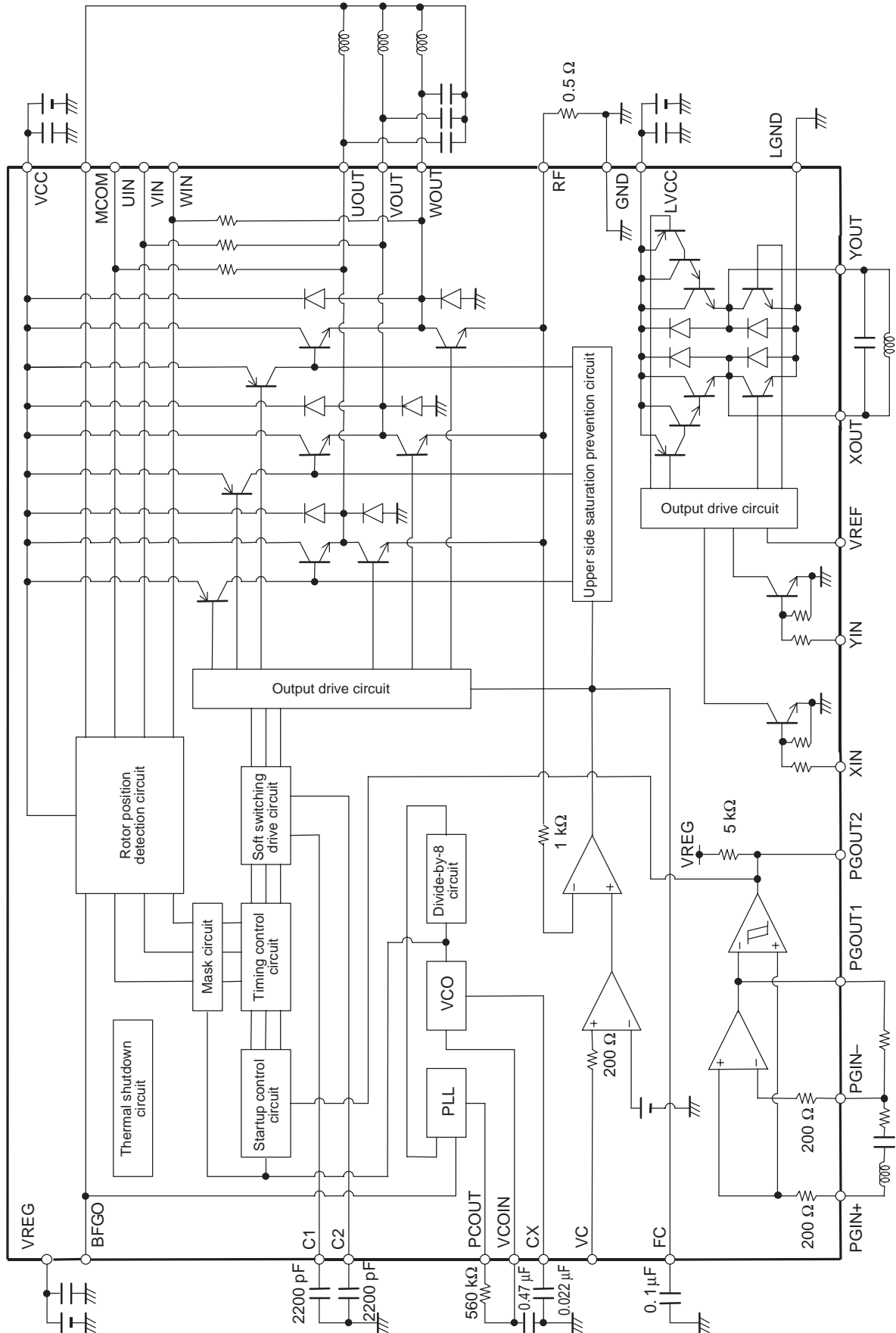

Pin Functions

Pin No.	Symbol	Voltage	Function	Equivalent circuit diagram
1	FC		Frequency characteristics correction. Insert a capacitor between this pin and ground to prevent closed-loop oscillation in the current control system.	
2	VC	0 V to V _{REG}	Speed control. This circuit implements a constant-current control scheme in which current feedback from the RF pin is applied.	
3	VREG	4 V to 6 V	Control system power supply. This power supply must be stabilized to prevent ripple or other noise entering the circuit.	
4	PGIN+		PG amplifier + input. This input is biased at 1/2 V _{REG} internally.	
5	PGIN-		PG amplifier - input.	
6	PGOUT1		PG amplifier linear output.	

Continued on next page.

LB1988N

Continued from preceding page.

Pin No.	Symbol	Voltage	Function	Equivalent circuit diagram
7	PGOUT2		PG Schmitt amplifier output.	
8	BFGO		Motor back EMF detection FG output (3-phase synthesized).	
9	LVCC	8 to 13.8 V	Loading motor driver output transistor power supply.	
10	VREF	0 to V_{CCL}	Loading motor driver output voltage setting.	
11	XIN	0 V to V_{REG}	Loading motor driver logic input.	
12	YIN			
13	XOUT		Loading motor driver output.	
15	YOUT			
14	LGND		Loading motor driver output transistor ground.	

Continued on next page.

LB1988N

Continued from preceding page.

Pin No.	Symbol	Voltage	Function	Equivalent circuit diagram
16	UOUT		Drum motor driver output.	
17	VOOUT			
18	WOOUT			
20	RF		Lowest potential of the drum motor driver output transistor. Constant-current control is implemented by detecting this voltage. The current limiter also functions by detecting this voltage.	
21	VCC	8 to 13.8 V	Internal reference voltage and power supply for the drum motor driver output block and coil waveform detection circuit.	
19	MCOM		Motor coil midpoint input. This voltage is used as the reference voltage in coil voltage waveform detection.	
22	UIN		Coil waveform detection comparator inputs. These are connected to each of the phase outputs through internal 10-kΩ resistors.	
23	VIN			
24	WIN			
25	C1		Triangular waveform generator capacitor connection. The triangular waveform generated using this pin is used to implement soft switching for the coil output waveforms.	
26	C2			
27	CX		The value of the capacitor connected between this pin and ground in the VCO circuit determines the operating frequency range and the minimum operating frequency.	

Continued on next page.

LB1988N

Continued from preceding page.

Pin No.	Symbol	Voltage	Function	Equivalent circuit diagram
28	VCOIN		VCO circuit control voltage input. The PCOUT pin voltage is applied to this pin through an RC filter.	
29	PCOUT		VCO circuit PLL output.	
30	GND		Ground used for all circuits other than the drum and loading motor driver output transistors.	

- Specifications of any and all SANYO products described or contained herein stipulate the performance, characteristics, and functions of the described products in the independent state, and are not guarantees of the performance, characteristics, and functions of the described products as mounted in the customer's products or equipment. To verify symptoms and states that cannot be evaluated in an independent device, the customer should always evaluate and test devices mounted in the customer's products or equipment.
- SANYO Electric Co., Ltd. strives to supply high-quality high-reliability products. However, any and all semiconductor products fail with some probability. It is possible that these probabilistic failures could give rise to accidents or events that could endanger human lives, that could give rise to smoke or fire, or that could cause damage to other property. When designing equipment, adopt safety measures so that these kinds of accidents or events cannot occur. Such measures include but are not limited to protective circuits and error prevention circuits for safe design, redundant design, and structural design.
- In the event that any or all SANYO products (including technical data, services) described or contained herein are controlled under any of applicable local export control laws and regulations, such products must not be exported without obtaining the export license from the authorities concerned in accordance with the above law.
- No part of this publication may be reproduced or transmitted in any form or by any means, electronic or mechanical, including photocopying and recording, or any information storage or retrieval system, or otherwise, without the prior written permission of SANYO Electric Co., Ltd.
- Any and all information described or contained herein are subject to change without notice due to product/technology improvement, etc. When designing equipment, refer to the "Delivery Specification" for the SANYO product that you intend to use.
- Information (including circuit diagrams and circuit parameters) herein is for example only; it is not guaranteed for volume production. SANYO believes information herein is accurate and reliable, but no guarantees are made or implied regarding its use or any infringements of intellectual property rights or other rights of third parties.

This catalog provides information as of July, 1999. Specifications and information herein are subject to change without notice.