

## 3.4cm (1.35-inch) Color LCD Panel

### Description

The LCX007AKA is a 3.4cm diagonal active matrix TFT-LCD panel addressed by polycrystalline silicon super thin film transistors with built-in peripheral driving circuit, and it provides a full-color representation. (The LCX007BKA is designed for direct viewing with polarizer attached on its both sides.)

This panel provides a wide aspect ratio of 16:9, such as those represented in HD. The built-in side-black function also allows an aspect ratio of 4:3 in the NTSC/PAL mode.

This panel has a polysilicon TFT high-speed scanner and built-in function to display images up/down and/or right/left inverse. The built-in 5V interface circuit leads to lower voltage of timing system and control signals.

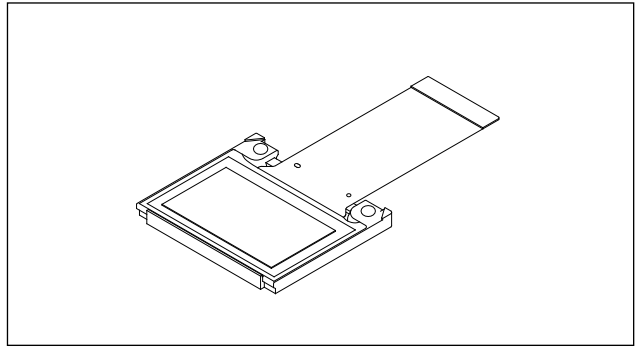

### Features

- The number of active dots: 512,880 (1.35-inch; 3.4cm in diagonal)
- Horizontal resolution: 400 TV lines
- High optical transmittance: 4.0% (typ.)
- High contrast ratio with normally white mode: 190 (typ.)
- Built-in H and V drivers (built-in input level conversion circuit, 5V driving possible)
- NTSC/NTSC-WIDE/HD (band: 20MHz) mode selectable  
(PAL/PAL-WIDE mode also available through conversion of scanned dot numbers by an external IC)
- Up/down and/or right/left inverse display function
- Side-black function
- 16:9 and 4:3 aspect-ratio switching function
- Full-color display

### Element Structure

- Dots
  - 16:9 display:  $1068.5 (H) \times 480 (V) = 512,880$
  - 4:3 display:  $799.5 (H) \times 480 (V) = 383,760$
- Built-in peripheral driver using polycrystalline silicon super thin film transistors.

### Applications

- Liquid crystal projectors
- Super compact liquid crystal monitors
- Viewfinders etc.

Sony reserves the right to change products and specifications without prior notice. This information does not convey any license by any implication or otherwise under any patents or other right. Application circuits shown, if any, are typical examples illustrating the operation of the devices. Sony cannot assume responsibility for any problems arising out of the use of these circuits.

Block Diagram

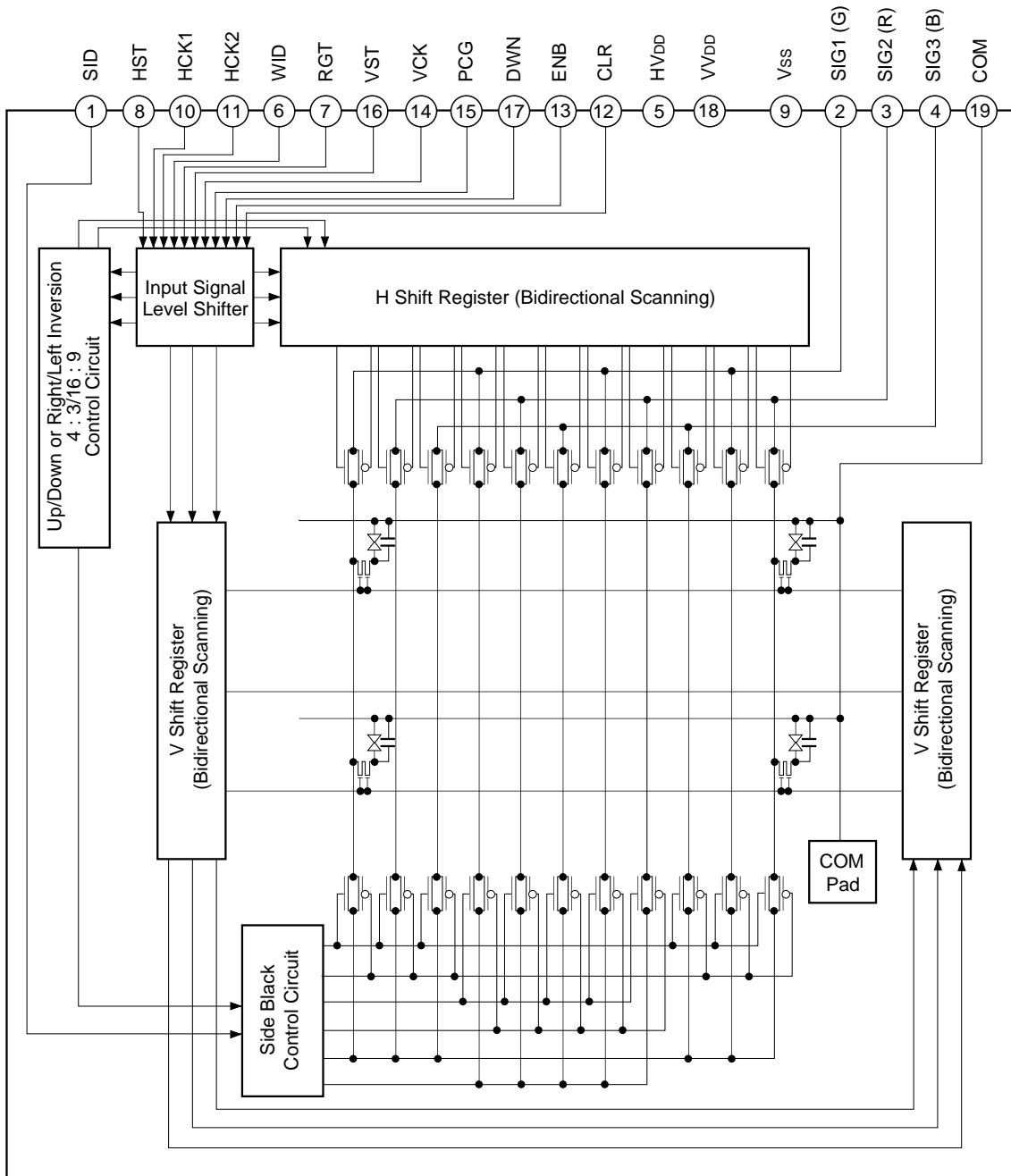

**Absolute Maximum Ratings** ( $V_{SS} = 0V$ )

• H driver supply voltage	HV <sub>DD</sub>	-1.0 to +20	V
• V driver supply voltage	VV <sub>DD</sub>	-1.0 to +20	V
• Common pad voltage	COM	-1.0 to +17	V
• H shift register input pin voltage	HST, HCK1, HCK2 RGT, WID	-1.0 to +17	V
• V shift register input pin voltage	VST, VCK, PCG CLR, ENB, DWN	-1.0 to +17	V
• Video signal input pin voltage	SIG1, SIG2, SIG3, SID	-1.0 to +15	V
• Operating temperature	Topr	-10 to +70	°C
• Storage temperature	Tstg	-30 to +85	°C

**Operating Conditions** ( $V_{SS} = 0V$ )

• Supply voltage			
	HV <sub>DD</sub>	15.7 <sup>+0.3</sup> <sub>-0.4</sub>	V
	VV <sub>DD</sub>	15.7 <sup>+0.3</sup> <sub>-0.4</sub>	V
• Input pulse voltage (V <sub>p-p</sub> of all input pins except video signal and side black signal input pins)			
	V <sub>in</sub>	5.0 ± 0.5	V

**Pin Description**

Pin No.	Symbol	Description	Pin No.	Symbol	Description
1	SID	Side black signal for 4:3 display	11	HCK2	Clock pulse for H shift register drive
2	SIG1 (G)	Video signal (G) to panel	12	CLR	Improvement pulse (1) for uniformity
3	SIG2 (R)	Video signal (R) to panel	13	ENB	Enable pulse for gate selection
4	SIG3 (B)	Video signal (B) to panel	14	VCK	Clock pulse for V shift register drive
5	HV <sub>DD</sub>	Power supply for H driver	15	PCG	Improvement pulse (2) for uniformity
6	WID	Aspect-ratio switching (H: 16:9, L: 4:3)	16	VST	Start pulse for V shift register drive
7	RGT	Drive direction pulse for H shift register (H: normal, L: reverse)	17	DWN	Drive direction pulse for V shift register (H: normal, L: reverse)
8	HST	Start pulse for H shift register drive	18	VV <sub>DD</sub>	Power supply for V driver
9	V <sub>SS</sub>	GND (H, V drivers)	19	COM	Common voltage of panel
10	HCK1	Clock pulse for H shift register drive	20	TEST	Test; Open

**Input Equivalent Circuit**

To prevent static charges, protective diodes are provided for each pin except the power supply. In addition, protective resistors are added to all pins except video signal input. All pins are connected to Vss with a high resistance of 1MΩ (typ.). The equivalent circuit of each input pin is shown below: (The resistor value: typ.)

(1) SIG1, SIG2, SIG3, SID

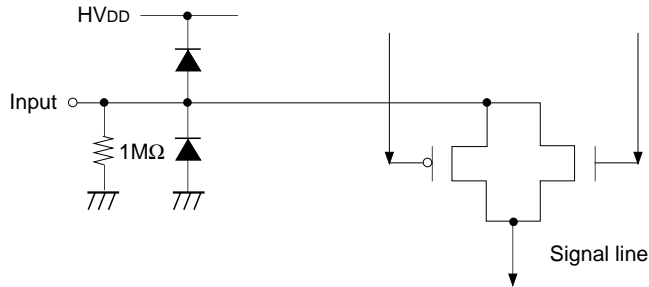

(2) HCK1, HCK2

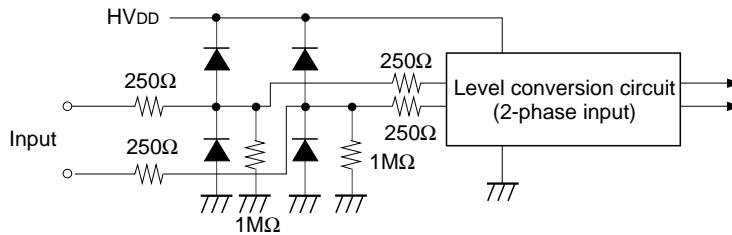

(3) RGT, WID

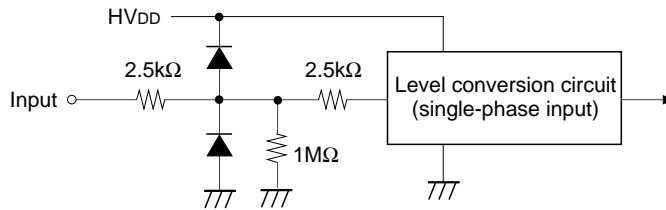

(4) HST

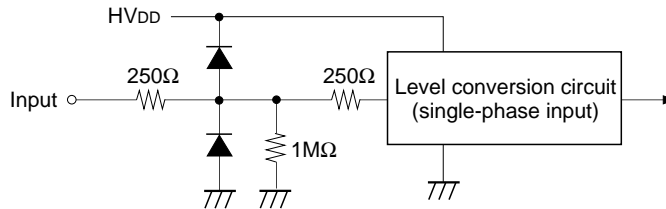

(5) PCG, VCK

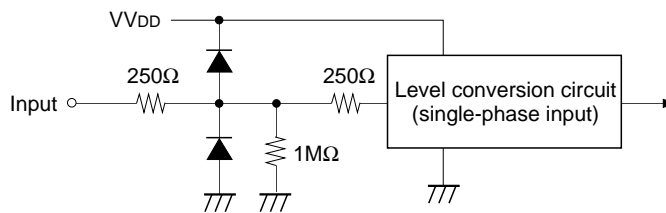

(6) VST, CLR, ENB, DWN

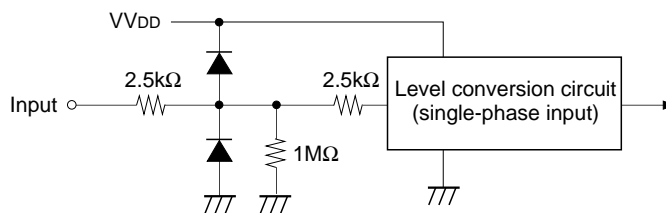

(7) COM

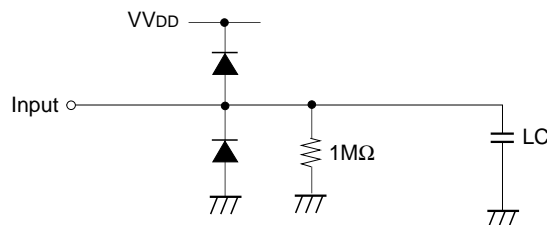

## Input Signals

### 1. Input signal voltage conditions

(V<sub>SS</sub> = 0V)

Item	Symbol	Min.	Typ.	Max.	Unit	
H driver input voltage WID, RGT, HST, HCK1, HCK2	(Low)	VHIL	-0.5	0.0	0.3	V
	(High)	VHIH	4.5	5.0	5.5	V
V driver input voltage CLR, ENB, VCK, PCG, VST, DWN	(Low)	VVIL	-0.5	0.0	0.3	V
	(High)	VVIH	4.5	5.0	5.5	V
Video signal center voltage	VVC	6.5	7.0	7.2	V	
Video signal input range*1	Vsig	VVC - 4.5	—	VVC + 4.5	V	
Common voltage of panel*2	Vcom	VVC - 0.5	VVC - 0.4	VVC - 0.3	V	

\*1 Video input signal shall be symmetrical to VVC.

\*2 Common voltage of the panel shall be adjusted to VVC - 0.4V.

### Level Conversion Circuit

The LCX007BKA has a built-in level conversion circuit in the clock input unit on the panel. The input signal level increases to HV<sub>DD</sub> or VV<sub>DD</sub>. The V<sub>CC</sub> of external ICs are applicable to 5 ± 0.5V.

## 2. Clock timing conditions

(Ta = 25°C) (fHCKn = 7.5MHz, fVCK = 15.7kHz)

	Item	Symbol	Min.	Typ.	Max.	Unit
HST	Hst rise time	trHst	—	—	30	ns
	Hst fall time	tfHst	—	—	30	
	Hst data set-up time	tdHst	20	67	100	
	Hst data hold time	thHst	-40	0	40	
HCK	Hckn* <sup>3</sup> rise time	trHckn	—	—	30	
	Hckn* <sup>3</sup> fall time	tfHckn	—	—	30	
	Hck1 fall to Hck2 rise time	to1Hck	-15	0	15	
	Hck1 rise to Hck2 fall time	to2Hck	-15	0	15	
CLR	Clr rise time	trClr	—	—	100	
	Clr fall time	tfClr	—	—	100	
	Clr pulse width	twClr	3000	3100	3200	
	Vck rise/fall to Clr fall time	tdClr	-50	0	50	
VST	Vst rise time	trVst	—	—	100	μs
	Vst fall time	tfVst	—	—	100	
	Vst data set-up time	tdVst	-25	15	25	
	Vst data hold time	thVst	5	15	25	
VCK	Vck rise time	trVck	—	—	100	ns
	Vck fall time	tfVck	—	—	100	
ENB	Enb rise time	trEnb	—	—	100	
	Enb fall time	tfEnb	—	—	100	
	Vck rise/fall to Enb rise time	tdEnb	350	400	450	
	Enb pulse width	twEnb	3450	3500	3550	
PCG	Pcg rise time	trPcg	—	—	20	
	Pcg fall time	tfPcg	—	—	20	
	Pcg fall to Vck rise/fall time	toVck	650	700	750	
	Pcg pulse width	twPcg	1150	1200	1250	

\*<sup>3</sup> Hckn means Hck1 and Hck2.

<Horizontal Shift Register Driving Waveform>

Item		Symbol	Waveform	Conditions
HST	Hst rise time	trHst		○ Hckn <sup>*3</sup> duty cycle 50% to1Hck = 0ns to2Hck = 0ns
	Hst fall time	tfHst		
	Hst data set-up time	tdHst		
	Hst data hold time	thHst		
HCK	Hckn <sup>*3</sup> rise time	trHckn		○ Hckn <sup>*3</sup> duty cycle 50% to1Hck = 0ns to2Hck = 0ns
	Hckn <sup>*3</sup> fall time	tfHckn		
	Hck1 fall to Hck2 rise time	to1Hck		
	Hck1 rise to Hck2 fall time	to2Hck		
CLR	Clr rise time	trClr		○ Hckn <sup>*3</sup> duty cycle 50% to1Hck = 0ns to2Hck = 0ns
	Clr fall time	tfClr		
	Clr pulse width	twClr		
	Vck rise/fall to Clr fall time	tdClr		

<Vertical Shift Register Driving Waveform>

Item		Symbol	Waveform	Conditions
VST	Vst rise time	trVst		
	Vst fall time	tfVst		
	Vst data set-up time	tdVst		
	Vst data hold time	thVst		
VCK	Vck rise time	trVck		
	Vck fall time	tfVck		
ENB	Enb rise time	trEnb		
	Enb fall time	tfEnb		
	Vck rise/fall to Enb rise time	tdEnb		
	Enb pulse width	twEnb		
PCG	Pcg rise time	trPcg		
	Pcg fall time	tfPcg		
	Pcg fall to Vck rise/fall time	toVck		
	Pcg pulse width	twPcg		

\*4 Definitions: The right-pointing arrow (  $\bullet \rightarrow$  ) means +.  
 The left-pointing arrow (  $\leftarrow \bullet$  ) means -.  
 The black dot at an arrow (  $\bullet$  ) indicates the start of measurement.



**Electrical Characteristics** ( $T_a = 25^\circ\text{C}$ ,  $HV_{DD} = 15.7\text{V}$ ,  $VV_{DD} = 15.7\text{V}$ )**1. Horizontal drivers**

Item	Symbol	Min.	Typ.	Max.	Unit	Condition	
Input pin capacitance	HCKn	CHckn	—	7	10	pF	
	HST	CHst	—	7	10	pF	
Input pin current	HCK1		-500	-120	—	$\mu\text{A}$	HCK1 = GND
	HCK2		-1000	-450	—	$\mu\text{A}$	HCK2 = GND
	HST		-500	-160	—	$\mu\text{A}$	HST = GND
	WID, RGT		-150	-30	—	$\mu\text{A}$	WID, RGT = GND
Video signal input pin capacitance	Csig	—	250	—	pF		
Current consumption	IH	—	7.5	10	mA	HCKn: HCK1, HCK2 (7.5MHz)	

**2. Vertical drivers**

Item	Symbol	Min.	Typ.	Max.	Unit	Condition	
Input pin capacitance	VCK	CVck	—	7	10	pF	
	VST	CVst	—	7	10	pF	
Input pin current	VCK		-1000	-160	—	$\mu\text{A}$	VCK = GND
PCG, VST, EN, CLR, DWN			-150	-30	—	$\mu\text{A}$	PCG, VST, EN, CLR, DWN = GND
Current consumption	IV	—	1.5	4	mA	VCK: (15.7kHz)	

**3. Total power consumption of the panel**

Item	Symbol	Min.	Typ.	Max.	Unit
Total power consumption of the panel (NTSC)	PWR	—	150	250	mW

**4. Pin input resistance**

Item	Symbol	Min.	Typ.	Max.	Unit
Pin-Vss input resistance	Rpin	0.4	1	—	$\text{M}\Omega$

**5. Side signal input pin capacitance**

Item	Symbol	Min.	Typ.	Max.	Unit
Side signal input pin capacitance	CSIDon	8	10	12	nF

Electro-optical Characteristics

(Ta = 25°C, NTSC mode)

Item			Symbol	Measurement method	Min.	Typ.	Max.	Unit
Contrast ratio	25°C		CR <sub>25</sub>	1	60	190	—	—
	60°C		CR <sub>60</sub>		100	190	—	
Optical transmittance			T	2	3.3	4.0	—	%
Chromaticity	R	X	R <sub>x</sub>	3	0.560	0.622	0.670	CIE standards
		Y	R <sub>y</sub>		0.300	0.347	0.390	
	G	X	G <sub>x</sub>		0.275	0.302	0.347	
		Y	G <sub>y</sub>		0.541	0.601	0.650	
	B	X	B <sub>x</sub>		0.120	0.144	0.187	
		Y	B <sub>y</sub>		0.040	0.087	0.122	
V-T characteristics	V <sub>90</sub>	25°C	V <sub>90-25</sub>	4	1.4	1.7	2.0	V
		60°C	V <sub>90-60</sub>		1.2	1.5	1.8	
	V <sub>50</sub>	25°C	V <sub>50-25</sub>		1.8	2.1	2.4	
		60°C	V <sub>50-60</sub>		1.6	1.9	2.2	
	V <sub>10</sub>	25°C	V <sub>10-25</sub>		2.4	2.7	3.0	
		60°C	V <sub>10-60</sub>		2.2	2.5	2.8	
Half tone color reproduction range		R vs. G	V <sub>50RG</sub>	5	—	-0.10	-0.25	V
		B vs. G	V <sub>50BG</sub>		—	0.15	0.50	
Response time	ON time	0°C	ton0	6	—	50	100	ms
		25°C	ton25		—	15	40	
	OFF time	0°C	toff0		—	52	150	
		25°C	toff25		—	16	60	
Flicker		60°C	F	7	—	-50	-30	dB
Image retention time		25°C	YT60	8	—	—	5	s

<Electro-optical Characteristics Measurement>

Basic measurement conditions

- (1) Driving voltage  
 $HV_{DD} = 15.7V, VV_{DD} = 15.7V$   
 $VVC = 7.0V, Vcom = 6.6V$
- (2) Measurement temperature  
 25°C unless otherwise specified.
- (3) Measurement point  
 One point in the center of screen unless otherwise specified.
- (4) Measurement systems  
 Two types of measurement system are used as shown below.
- (5) Video input signal voltage ( $V_{sig}$ )  
 $V_{sig} = 7.0 \pm V_{AC} [V]$  ( $V_{AC}$ : signal amplitude)

• Measurement system I

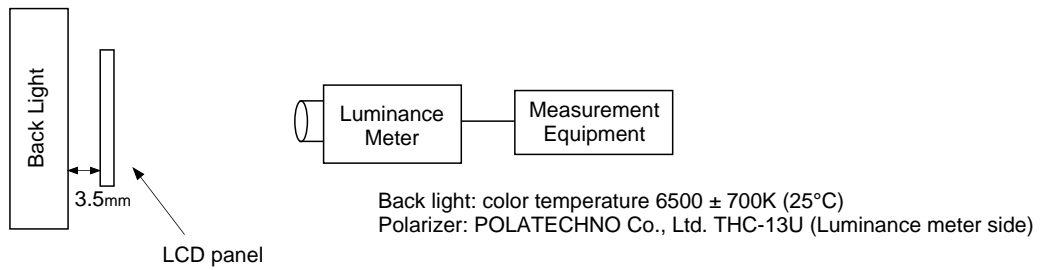

• Measurement system II

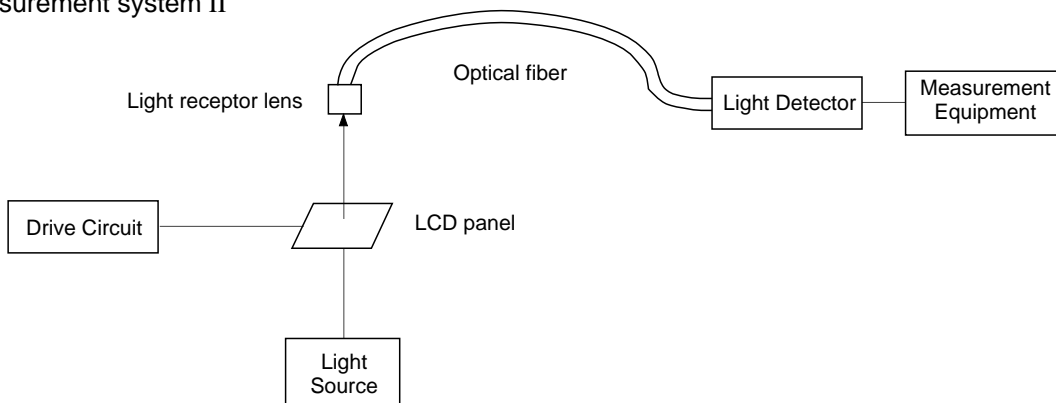

1. Contrast Ratio

Contrast Ratio (CR) is given by the following formula (1).

$$CR = \frac{L (White)}{L (Black)} \dots (1)$$

L (White): Surface luminance of the TFT-LCD panel at the input signal amplitude  $V_{AC} = 0.5V$ .

L (Black): Surface luminance of the panel at  $V_{AC} = 4.5V$ .

Both luminosities are measured by System I.

**2. Optical Transmittance**

Optical Transmittance (T) is given by the following formula (2).

$$T = \frac{L \text{ (White)}}{\text{Luminance of Back Light}} \times 100 \text{ [%] ... (2)}$$

L (White) is the same expression as defined in the 'Contrast Ratio' section.

**3. Chromaticity**

Chromaticity of the panels are measured by System I. Raster modes of each color are defined by the representations at the input signal amplitude conditions shown in the table below. System I uses Chromaticity of x and y on the CIE standards here.

		Signal amplitudes (V <sub>AC</sub> ) supplied to each input		
		R input	G input	B input
Raster	R	0.5	4.5	4.5
	G	4.5	0.5	4.5
	B	4.5	4.5	0.5

(Unit: V)

**4. V-T Characteristics**

V-T characteristics, the relationship between signal amplitude and the transmittance of the panels, are measured by System II. V<sub>90</sub>, V<sub>50</sub> and V<sub>10</sub> correspond to the each voltage which defines 90%, 50% and 10% of transmittance respectively.

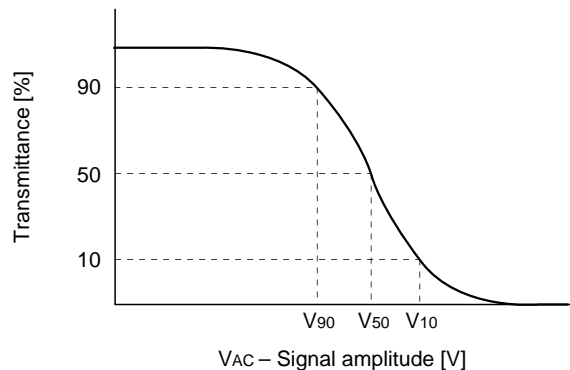

**5. Half Tone Color Reproduction Range**

Half tone color reproduction range of the LCD panels is characterized by the differences between the V-T characteristics of R, G and B. The differences of these V-T characteristics are measured by System II. System II defines signal voltages of each R, G, B raster modes which corresponds to 50% of transmittance, V<sub>50R</sub>, V<sub>50G</sub> and V<sub>50B</sub> respectively. V<sub>50RG</sub> and V<sub>50BG</sub>, the voltage differences between V<sub>50R</sub> and V<sub>50G</sub>, V<sub>50B</sub> and V<sub>50G</sub>, are simply given by the following formula (3) and (4) respectively.

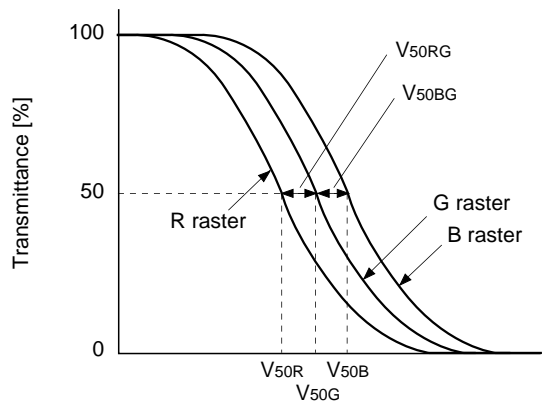

$$V_{50RG} = V_{50R} - V_{50G} \text{ ... (3)}$$

$$V_{50BG} = V_{50B} - V_{50G} \text{ ... (4)}$$

**6. Response Time**

Response time 'ton' and 'toff' are defined by the formula (5) and (6) respectively.

$$t_{on} = t_1 - t_{ON} \dots (5)$$

$$t_{off} = t_2 - t_{OFF} \dots (6)$$

t1: time which gives 10% transmittance of the panel.

t2: time which gives 90% transmittance of the panel.

The relationships between t1, t2, tON and tOFF are shown in the right figure.

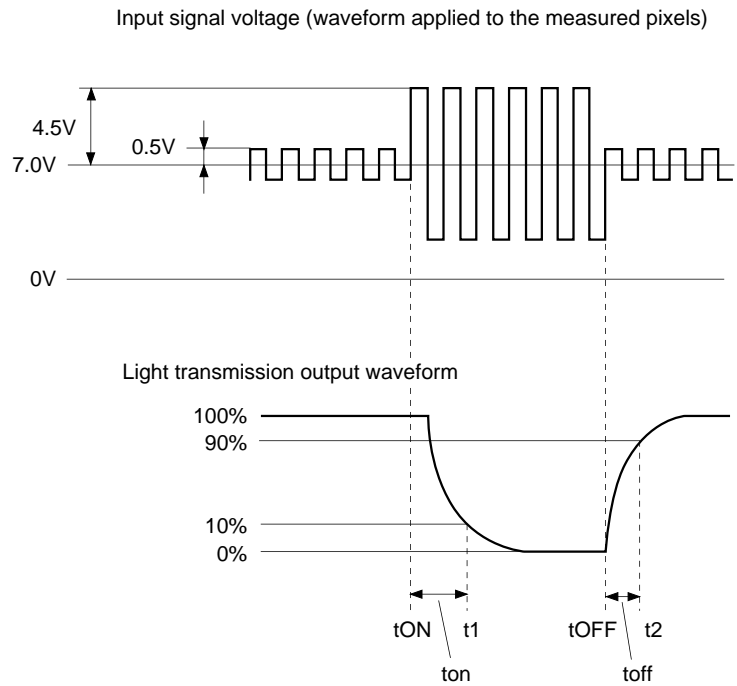

**7. Flicker**

Flicker (F) is given by the formula (7). DC and AC (NTSC: 30Hz, rms, PAL: 25Hz, rms) components of the panel output signal for gray raster\* mode are measured by a DC voltmeter and a spectrum analyzer in System II.

$$F [dB] = 20 \log \left\{ \frac{AC \text{ component}}{DC \text{ component}} \right\} \dots (7)$$

\* Each input signal condition for gray raster mode is given by  $V_{sig} = 7.0 \pm V_{50}$  [V] where:  $V_{50}$  is the signal amplitude which gives 50% of transmittance in V-T characteristics.

**8. Image Retention Time**

Image Retention time is given by following procedures.

Apply the monoscope signal to the LCD panel for 60 minutes and then change this signal to the gray scale of  $V_{sig} = 7.0 \pm V_{AC}$  ( $V_{AC}$ : 3 to 4V). Hold  $V_{AC}$  that maximizes image retention judging by sight. Measure the time till the residual image becomes indistinct.

\* Monoscope signal conditions:  
 $V_{sig} = 7.0 \pm 4.5$  or  $\pm 2.0$  [V]  
 (shown in the right figure)  
 $V_{com} = 6.6V$

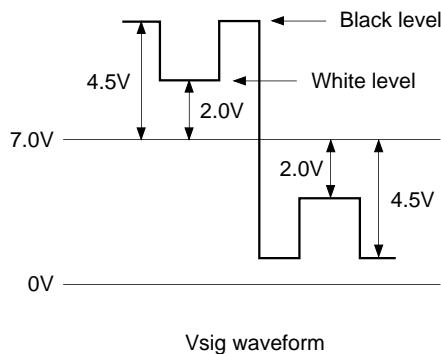

Optical transmittance of LCD panel (Typical value)

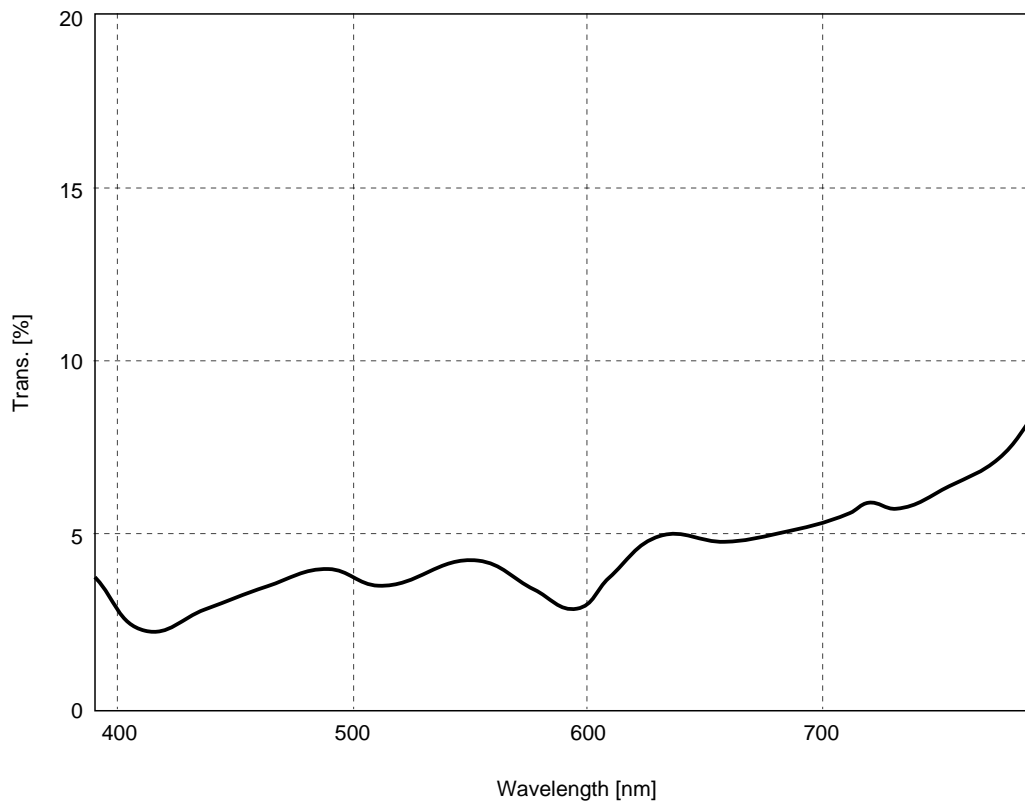

Measurement method: Measurement system II

Viewing angle characteristics (Typical value)

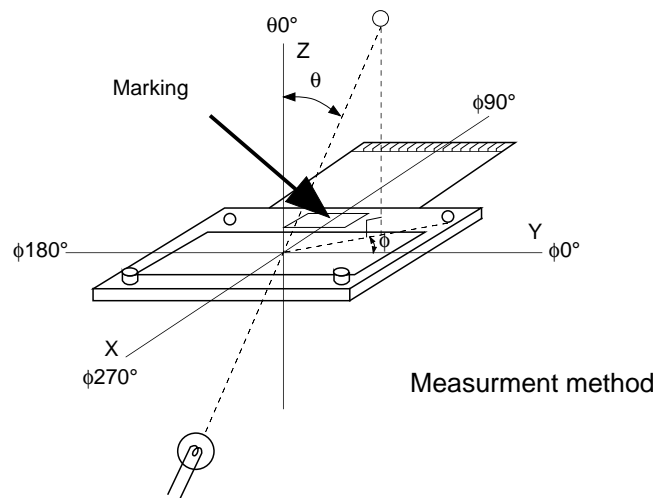
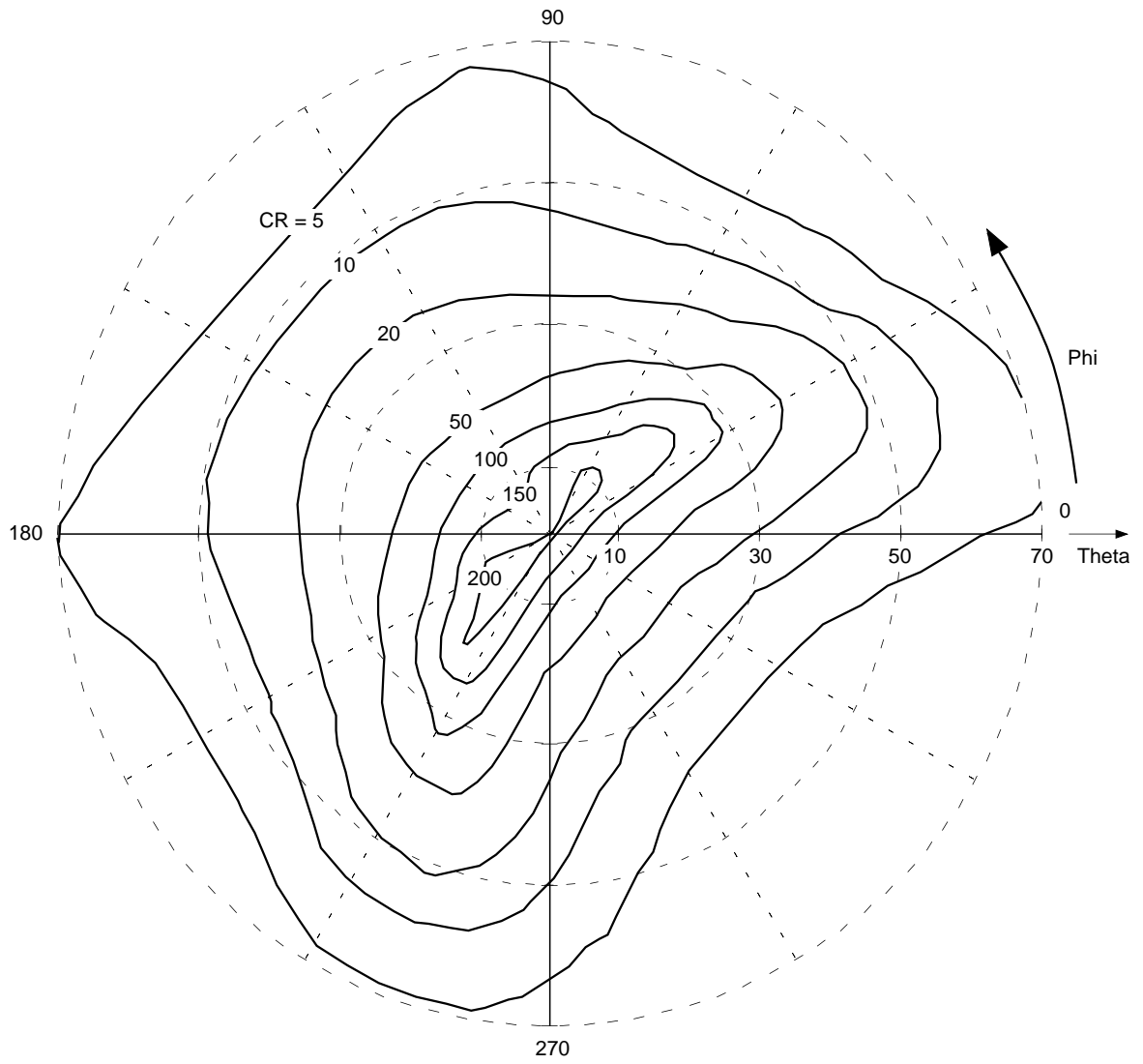

**Description of Operation**

**1. Dot Arrangement (1) (16:9 display)**

The dots are arranged in a delta pattern. The shaded area is used for the dark border around the display.

The R corresponds to SIG2, G to SIG1, and B to SIG3, respectively.

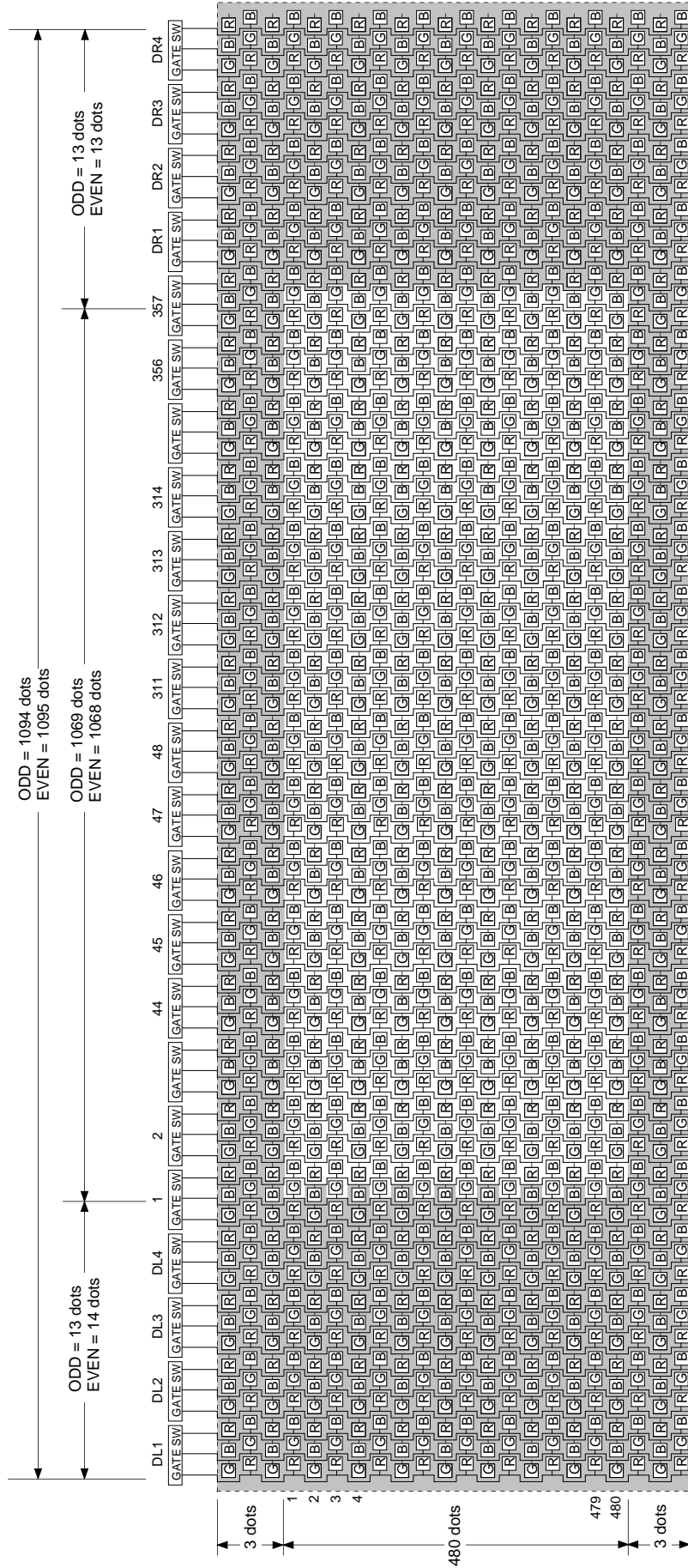



**Dot Arrangement (2) (4:3 display)**

The dots are arranged in a delta pattern. The shaded area is used for the dark border around the display. The R corresponds to SIG2, G to SIG1, and B to SIG3, respectively.

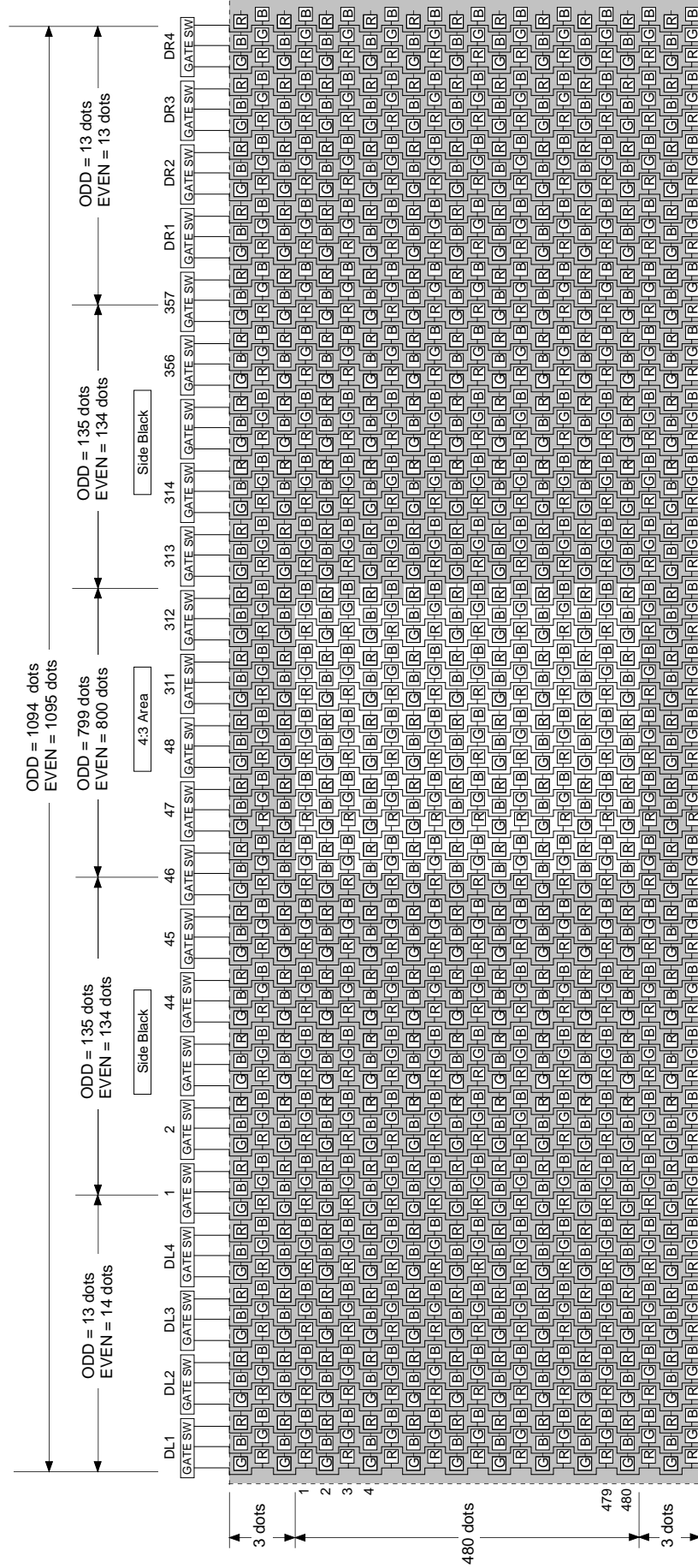

2. LCD Panel Operations

[Description of basic operations]

The basic operations of the LCD panel are shown below based on the wide-display mode.

- A vertical driver, which consists of vertical shift registers, enable-gates and buffers, applies a selected pulse to every 480 gate lines sequentially in every horizontal scanning period.
- A horizontal driver, which consists of horizontal shift registers, gates and CMOS sample-and-hold circuits, applies selected pulses to every 1068.5 signal electrodes sequentially in a single horizontal scanning period.
- Vertical and horizontal shift registers address one pixel, and then turn on Thin Film Transistors (TFTs; two TFTs) to apply a video signal to the dot. The same procedures lead to the entire 480 × 1068.5 dots to display a picture in a single vertical scanning period.
- The LCD pixel dots are arranged in a delta pattern, where the dots connected to the identical signal line are positioned with 1.5-dot offset against those of the adjacent horizontal line. Horizontal Start Pulse (HST) is generated with 1.5-bit offset between the horizontal lines to regulate the above offset. HCK and sample-and-hold (S/H) pulses follow the same 1.5-bit offset scheme.
- The CLR pin is provided to eliminate the shading effect caused by the coupling of selected pulses. While maintaining the CLR at High level, the VVDD potential drops to approximately 9.5V. This pin shall be grounded when not in use.
- The video signal shall be input with polarity-inverted system in every horizontal cycle.
- Timing diagrams of the vertical and the horizontal display cycle are shown below:

(1) Vertical display cycle

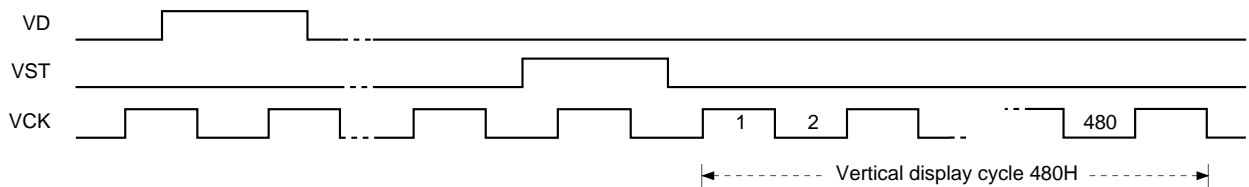

(2) Horizontal display cycle (16:9)

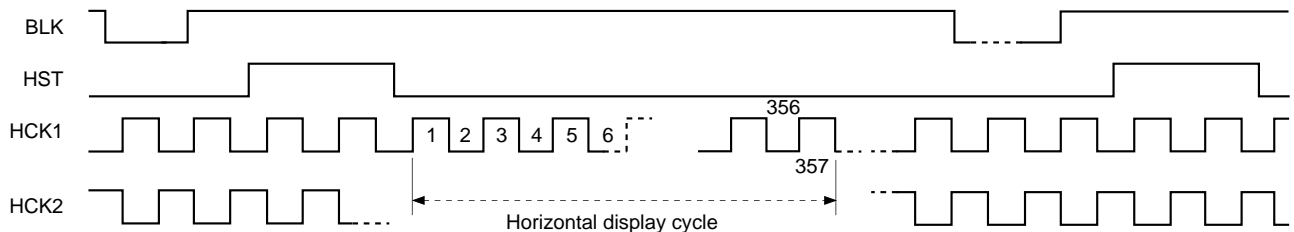

(3) Horizontal display cycle (4:3)

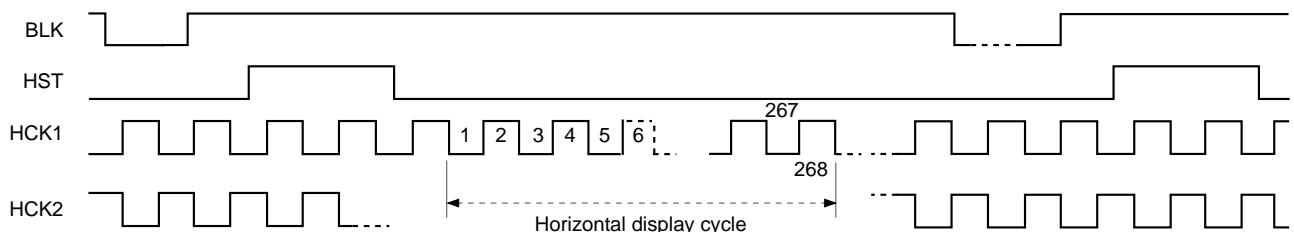

**[Description of operating mode]**

The LCD panel has the following functions to easily apply to various uses, as well as various broadcasting systems.

- Right/left inverse mode
- Up/down inverse mode
- 4:3 display mode with side-black display

These modes are controlled by three signals (RGT, DWN, and WID). The setting mode is shown below:

WID	RGT	Mode
H	H	16:9 right scan
H	L	16:9 left scan
L	H	4:3 right scan
L	L	4:3 left scan

DWN	Mode
H	Down scan
L	Up scan

The direction of the right/left and/or up/down mean when Pin 1 marking is located at right side with the pin block upside.

- The analog signal (SID) to display side-black shall be input by 1H inversion synchronized with the signal.

**3. 3-dot Simultaneous Sampling**

Horizontal driver samples SIG1, SIG2 and SIG3 signal simultaneously, which requires the phase matching between SIG1, SIG2, and SIG3 signals to prevent horizontal resolution from deteriorating. Thus phase matching between each signal is required using an external signal delaying circuit before applying video signal to the LCD panel.

The block diagram of the delaying procedure using sample-and-hold method is as follows.

The LCX007 has the right/left inverse function. The following phase relationship diagram indicates the phase setting for the right scan (RGT = High level). For the left scan (RGT = Low level), the phase setting shall be inverted between SIG2 and SIG3 signals.

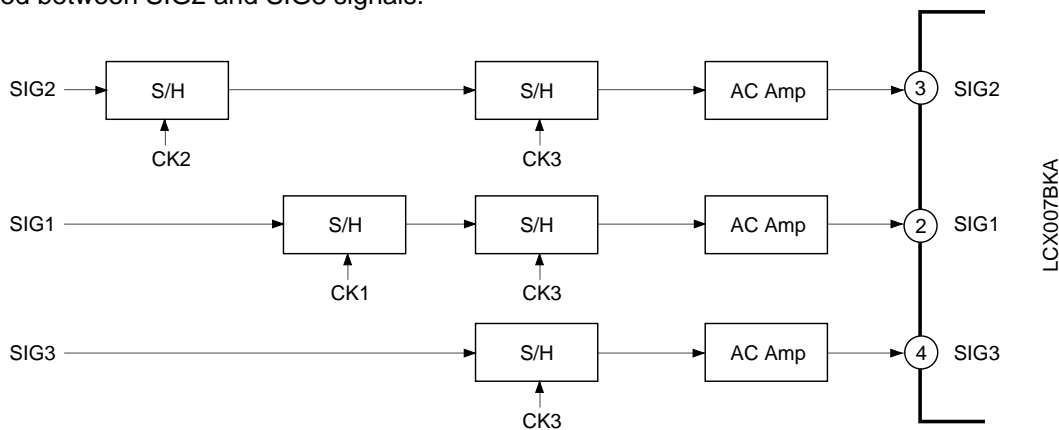

**<Phase relationship of delaying sample-and-hold pulses> (right scan)**

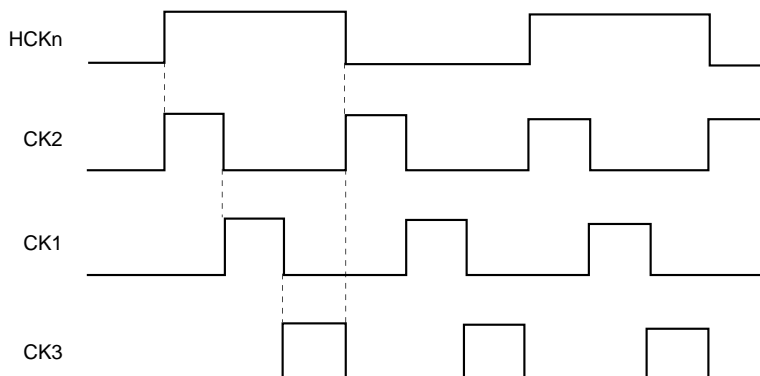

Example of Color Filter Spectrum (Reference)

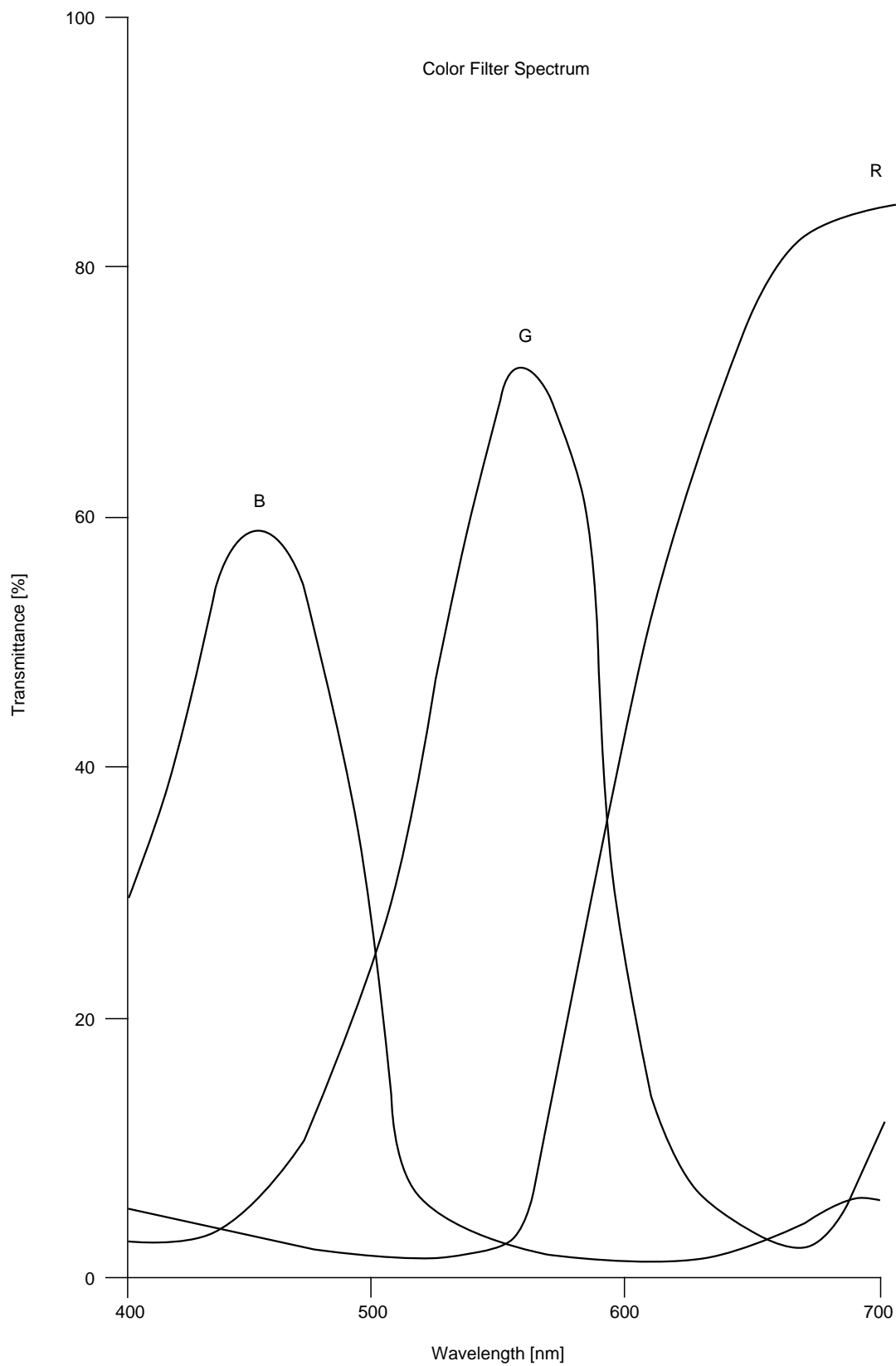

**Display System Block Diagram**

An example of display system is shown below.

\* The SIG1, 2, 3 and H SYNC signals with double-speed processing shall be applied to those pins in the NTSC/PAL modes.

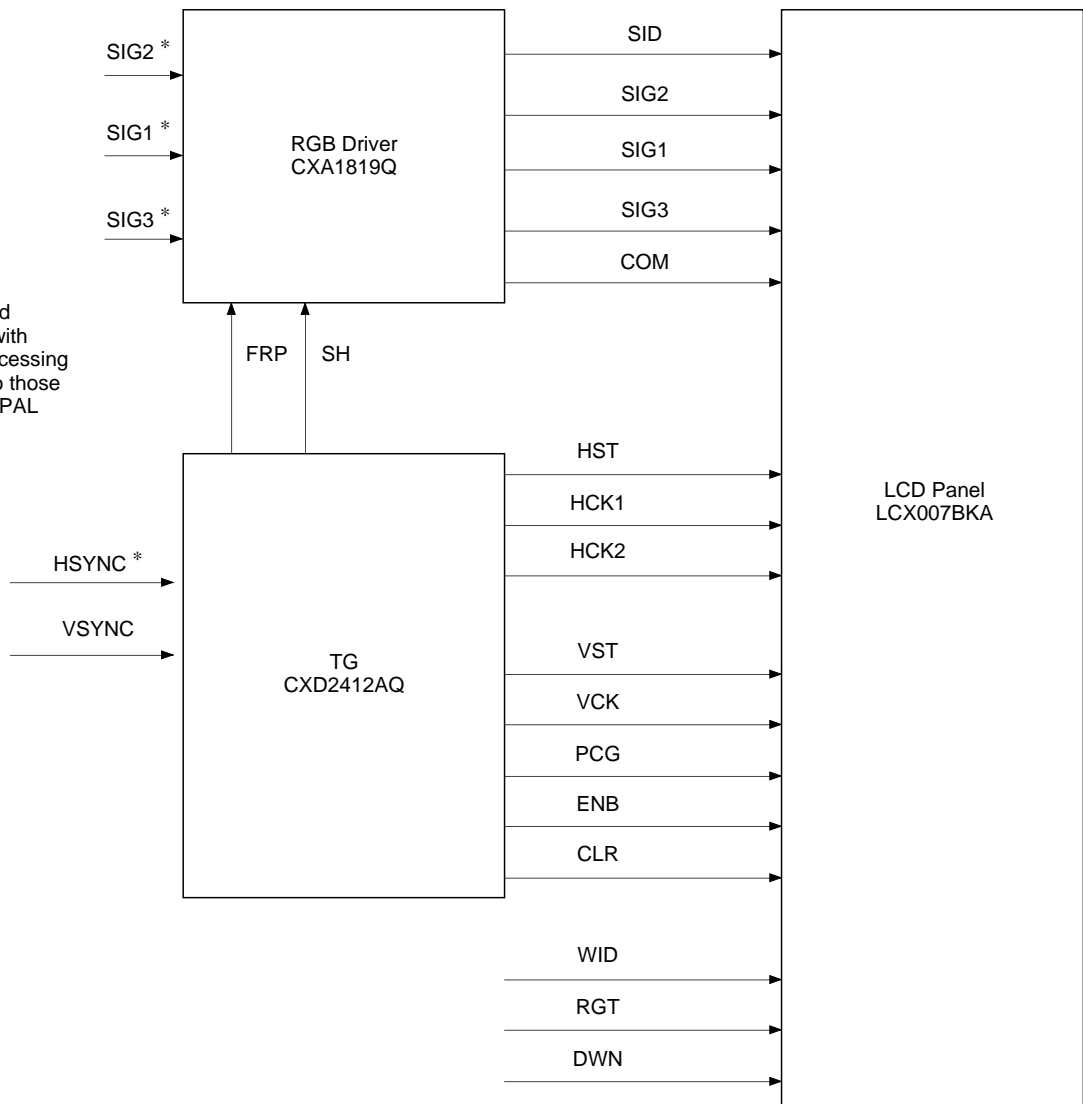

**Reliability test conditions**

Items	Test conditions	Time	Criterion
High temperature operation	Ta = 70°C HV <sub>DD</sub> = 15.7V VV <sub>DD</sub> = 15.7V	250h	Panel appearance and performance after those tests must conform with the standards.
High temperature storage	Ta = 85°C	250h	
High temperature & high humidity storage	Ta = 40°C 95% RH	250h	
Temperature cycle	Ta = -30 to +85°C	10cy	
Vibration	X, Y, Z, 1.5mm 10 to 55Hz (1min. reciprocation)	20min. for each direction	

**Important****(1) Direction of incident light**

Allow incident light to hit upon an opposite side of a mark-indicated surface.

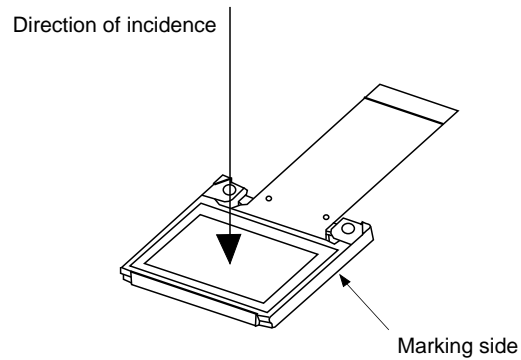
**(2) Polarizer**

This LCD is attached with a polarizer. A suitable heat-dissipation method shall be incorporated to suppress optical degradation of a polarizer.

**(3) Light source**

- Use visible light (wavelength  $\lambda = 400$  to  $780\text{nm}$ ) as a light source. Do not use a light source containing infrared or ultraviolet components.
- Suppress leakage light (reflection light) into a backside of a panel to sufficiently weak level or shut it out completely.

**Notes on Handling**

## (1) Static charge prevention

Be sure to take following protective measures. TFT-LCD panels are easily damaged by static charge.

- a) Use non-chargeable gloves, or simply use bare hands.
- b) Use an earth-band when handling.
- c) Do not touch any electrodes of a panel.
- d) Wear non-chargeable clothes and conductive shoes.
- e) Install conductive mat on the working floor and working table.
- f) Keep panels away from any charged materials.
- g) Use ionized air to discharge the panels.

## (2) Protection from dust and dirt

- a) Handle in clean environment.
- b) When delivered, a surface of a panel (Polarizer) is covered by a protective sheet.  
Peel off the protective sheet carefully not to damage the panel.
- c) Do not touch the surface of a panel. The surface is easily scratched. When cleaning, use a clean-room wiper with isopropyl alcohol. Be careful not to leave stain on the surface.
- d) Use ionized air to blow off dust at a panel.

## (3) Other handling precautions

- a) Do not twist or bend the flexible PC board especially at the connecting region because the board is easily deformed.
- b) Do not drop a panel.
- c) Do not twist or bend a panel or a panel frame.
- d) Keep a panel away from heat source.
- e) Do not dampen a panel with water or other solvents.
- f) Avoid to store or to use a panel in a high temperature or in a high humidity, which may result in panel damages.
- g) Minimum bent radius rating for flexible substrates is 1mm.
- h) Panel screw torque should not exceed 3kg · cm.



Package Outline

Unit: mm

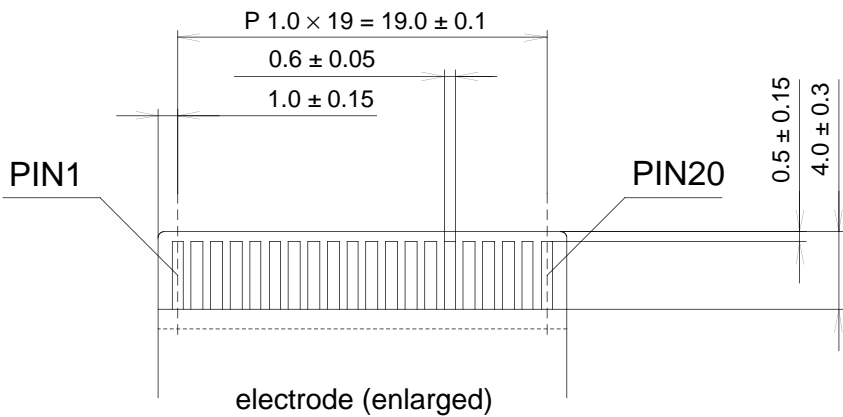
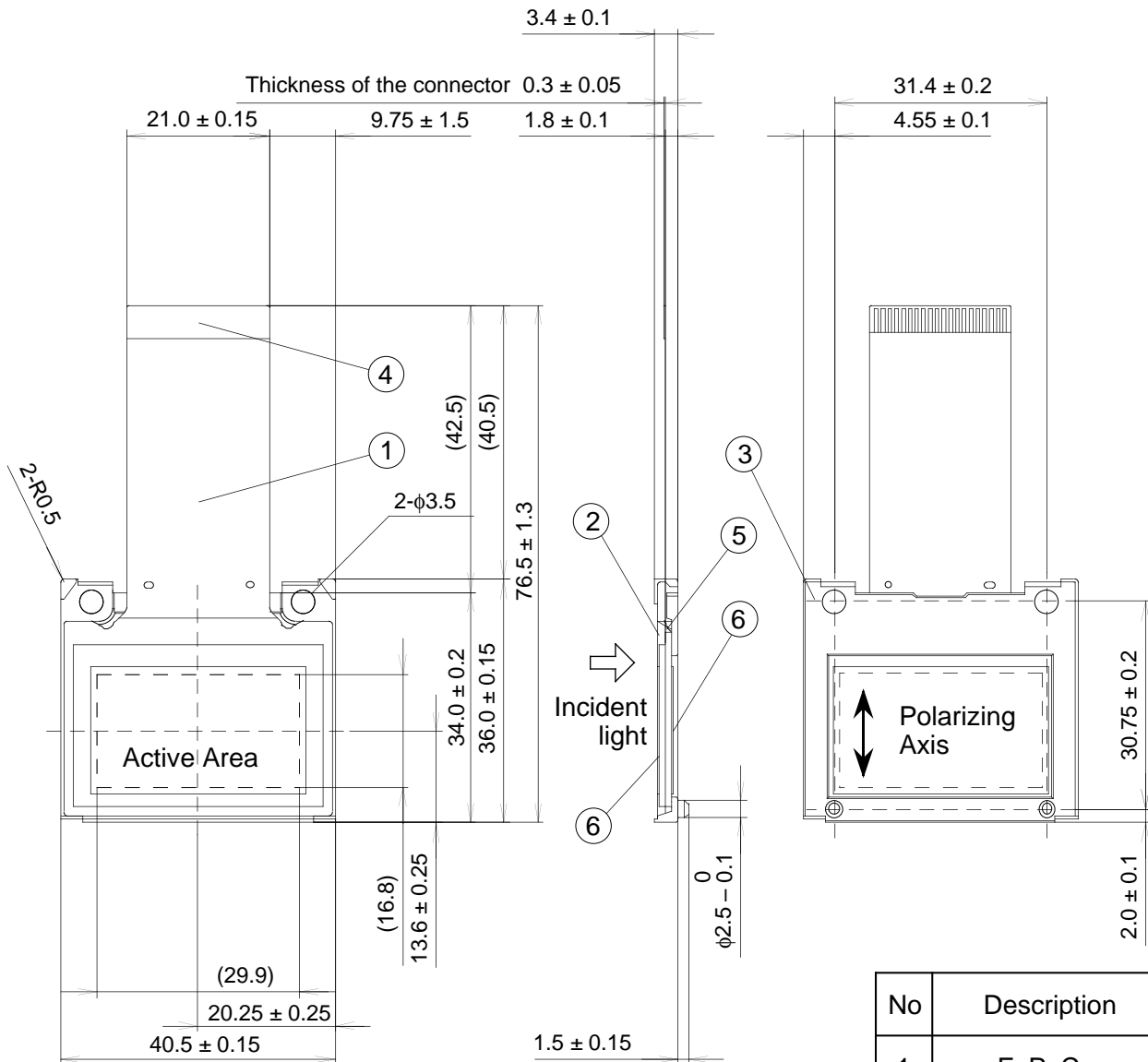

No	Description
1	F P C
2	Molding material
3	Outside frame
4	Reinforcing board
5	Reinforcing material
6	Polarizing film

weight 7g

The rotation angle of the active area relative to H and V is ± 1°.