



## **LatticeECP/EC Family Data Sheet**

---

DS1000 Version 02.7, February 2008

## Features

### ■ Extensive Density and Package Options

- 1.5K to 32.8K LUT4s
- 65 to 496 I/Os
- Density migration supported

### ■ sysDSP™ Block (LatticeECP™ Versions)

- High performance multiply and accumulate
- 4 to 8 blocks
  - 4 to 8 36x36 multipliers or
  - 16 to 32 18x18 multipliers or
  - 32 to 64 9x9 multipliers

### ■ Embedded and Distributed Memory

- 18 Kbits to 498 Kbits sysMEM™ Embedded Block RAM (EBR)
- Up to 131 Kbits distributed RAM
- Flexible memory resources:
  - Distributed and block memory

### ■ Flexible I/O Buffer

- Programmable sysI/O™ buffer supports wide range of interfaces:

- LVCMOS 3.3/2.5/1.8/1.5/1.2
- LVTTTL
- SSTL 3/2 Class I, II, SSTL18 Class I
- HSTL 18 Class I, II, III, HSTL15 Class I, III
- PCI
- LVDS, Bus-LVDS, LVPECL, RSDS

### ■ Dedicated DDR Memory Support

- Implements interface up to DDR400 (200MHz)

### ■ sysCLOCK™ PLLs

- Up to four analog PLLs per device
- Clock multiply, divide and phase shifting

### ■ System Level Support

- IEEE Standard 1149.1 Boundary Scan, plus ispTRACY™ internal logic analyzer capability
- SPI boot flash interface
- 1.2V power supply

### ■ Low Cost FPGA

- Features optimized for mainstream applications
- Low cost TQFP and PQFP packaging

**Table 1-1. LatticeECP/EC Family Selection Guide**

Device	LFEC1	LFEC3	LFEC6/ LFCEP6	LFEC10/ LFCEP10	LFEC15/ LFCEP15	LFEC20/ LFCEP20	LFEC33/ LFCEP33
PFU/PFF Rows	12	16	24	32	40	44	64
PFU/PFF Columns	16	24	32	40	48	56	64
PFUs/PFFs	192	384	768	1280	1920	2464	4096
LUTs (K)	1.5	3.1	6.1	10.2	15.4	19.7	32.8
Distributed RAM (Kbits)	6	12	25	41	61	79	131
EBR SRAM (Kbits)	18	55	92	276	350	424	498
EBR SRAM Blocks	2	6	10	30	38	46	54
sysDSP Blocks <sup>1</sup>	—	—	4	5	6	7	8
18x18 Multipliers <sup>1</sup>	—	—	16	20	24	28	32
V <sub>CC</sub> Voltage (V)	1.2	1.2	1.2	1.2	1.2	1.2	1.2
Number of PLLs	2	2	2	4	4	4	4
<b>Packages and I/O Combinations:</b>							
100-pin TQFP (14 x 14 mm)	67	67					
144-pin TQFP (20 x 20 mm)	97	97	97				
208-pin PQFP (28 x 28 mm)	112	145	147	147			
256-ball fpBGA (17 x 17 mm)		160	195	195	195		
484-ball fpBGA (23 x 23 mm)			224	288	352	360	360
672-ball fpBGA (27 x 27 mm)						400	496

1. LatticeECP devices only.

---

## Introduction

The LatticeECP/EC family of FPGA devices is optimized to deliver mainstream FPGA features at low cost. For maximum performance and value, the LatticeECP™ (EConomy Plus) FPGA concept combines an efficient FPGA fabric with high-speed dedicated functions. Lattice's first family to implement this approach is the LatticeECP-DSP™ (EConomy Plus DSP) family, providing dedicated high-performance DSP blocks on-chip. The LatticeEC™ (EConomy) family supports all the general purpose features of LatticeECP devices without dedicated function blocks to achieve lower cost solutions.

The LatticeECP/EC FPGA fabric, which was designed from the outset with low cost in mind, contains all the critical FPGA elements: LUT-based logic, distributed and embedded memory, PLLs and support for mainstream I/Os. Dedicated DDR memory interface logic is also included to support this memory that is becoming increasingly prevalent in cost-sensitive applications.

The ispLEVER® design tool suite from Lattice allows large complex designs to be efficiently implemented using the LatticeECP/EC FPGA family. Synthesis library support for LatticeECP/EC is available for popular logic synthesis tools. The ispLEVER tool uses the synthesis tool output along with the constraints from its floor planning tools to place and route the design in the LatticeECP/EC device. The ispLEVER tool extracts the timing from the routing and back-annotates it into the design for timing verification.

Lattice provides many pre-designed IP (Intellectual Property) ispLeverCORE™ modules for the LatticeECP/EC family. By using these IPs as standardized blocks, designers are free to concentrate on the unique aspects of their design, increasing their productivity.

## Architecture Overview

The LatticeECP-DSP and LatticeEC architectures contain an array of logic blocks surrounded by Programmable I/O Cells (PIC). Interspersed between the rows of logic blocks are rows of sysMEM Embedded Block RAM (EBR), as shown in Figures 2-1 and 2-2. In addition, LatticeECP-DSP supports an additional row of DSP blocks, as shown in Figure 2-2.

There are two kinds of logic blocks, the Programmable Functional Unit (PFU) and Programmable Functional unit without RAM/ROM (PFF). The PFU contains the building blocks for logic, arithmetic, RAM, ROM and register functions. The PFF block contains building blocks for logic, arithmetic and ROM functions. Both PFU and PFF blocks are optimized for flexibility, allowing complex designs to be implemented quickly and efficiently. Logic Blocks are arranged in a two-dimensional array. Only one type of block is used per row. The PFU blocks are used on the outside rows. The rest of the core consists of rows of PFF blocks interspersed with rows of PFU blocks. For every three rows of PFF blocks there is a row of PFU blocks.

Each PIC block encompasses two PIOs (PIO pairs) with their respective sysI/O interfaces. PIO pairs on the left and right edges of the device can be configured as LVDS transmit/receive pairs. sysMEM EBRs are large dedicated fast memory blocks. They can be configured as RAM or ROM.

The PFU, PFF, PIC and EBR Blocks are arranged in a two-dimensional grid with rows and columns as shown in Figure 2-1. The blocks are connected with many vertical and horizontal routing channel resources. The place and route software tool automatically allocates these routing resources.

At the end of the rows containing the sysMEM Blocks are the sysCLOCK Phase Locked Loop (PLL) Blocks. These PLLs have multiply, divide and phase shifting capability; they are used to manage the phase relationship of the clocks. The LatticeECP/EC architecture provides up to four PLLs per device.

Every device in the family has a JTAG Port with internal Logic Analyzer (ispTRACY) capability. The sysCONFIG™ port which allows for serial or parallel device configuration. The LatticeECP/EC devices use 1.2V as their core voltage.

Figure 2-1. Simplified Block Diagram, LatticeEC Device (Top Level)

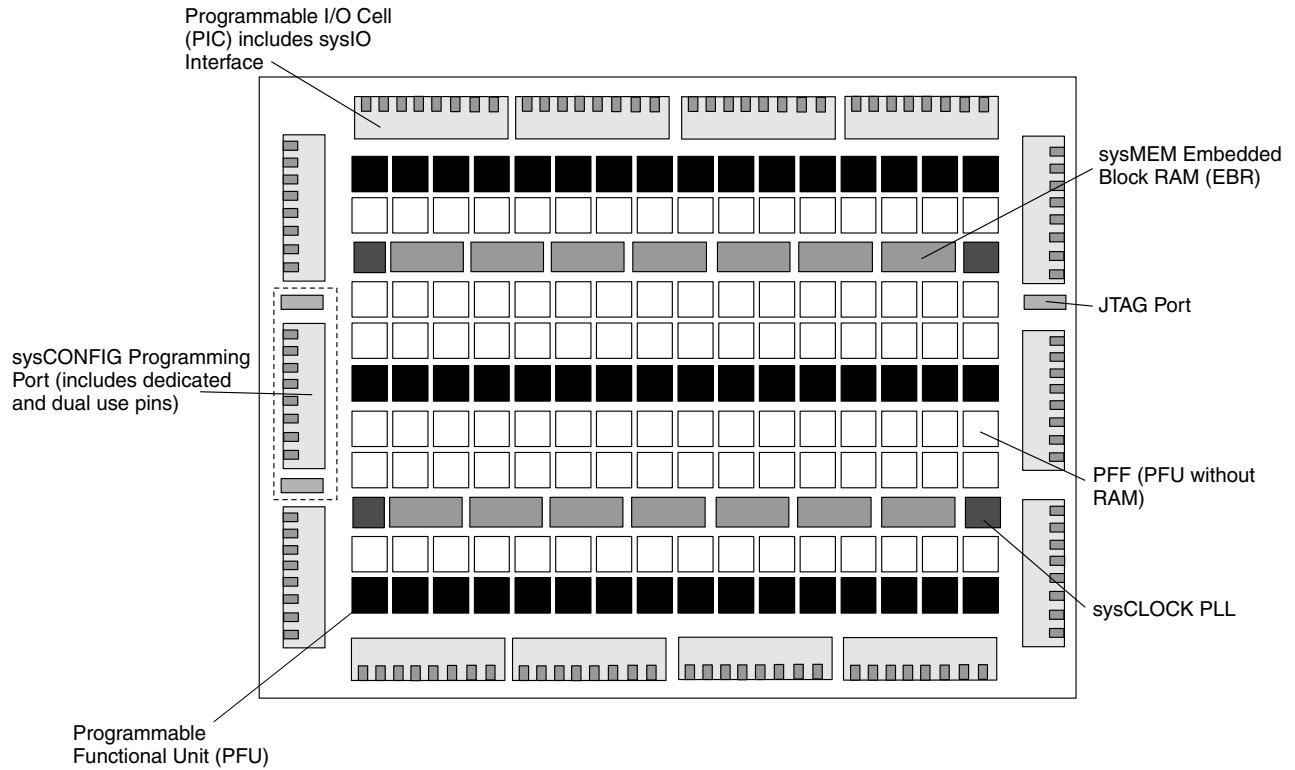
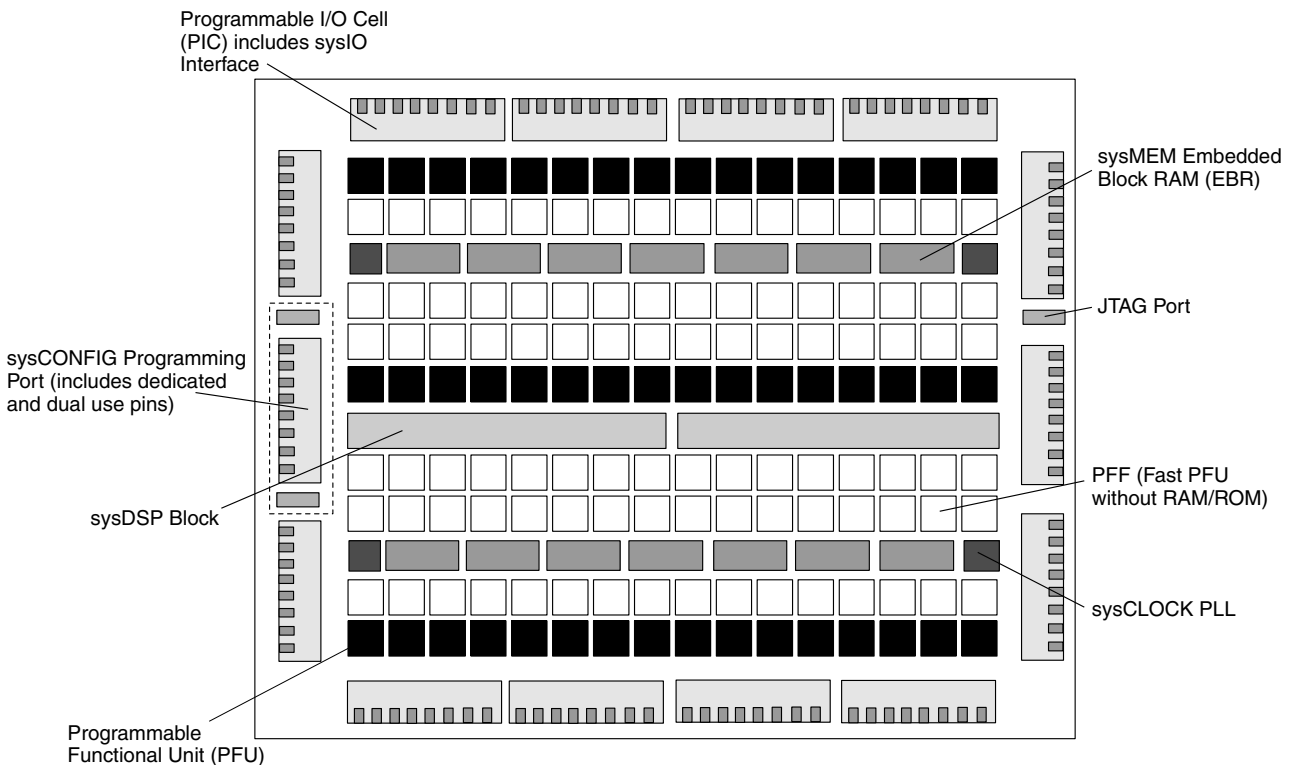

Figure 2-2. Simplified Block Diagram, LatticeECP-DSP Device (Top Level)



## PFU and PFF Blocks

The core of the LatticeECP/EC devices consists of PFU and PFF blocks. The PFUs can be programmed to perform Logic, Arithmetic, Distributed RAM and Distributed ROM functions. PFF blocks can be programmed to perform Logic, Arithmetic and ROM functions. Except where necessary, the remainder of the data sheet will use the term PFU to refer to both PFU and PFF blocks.

Each PFU block consists of four interconnected slices, numbered 0-3 as shown in Figure 2-3. All the interconnections to and from PFU blocks are from routing. There are 53 inputs and 25 outputs associated with each PFU block.

Figure 2-3. PFU Diagram

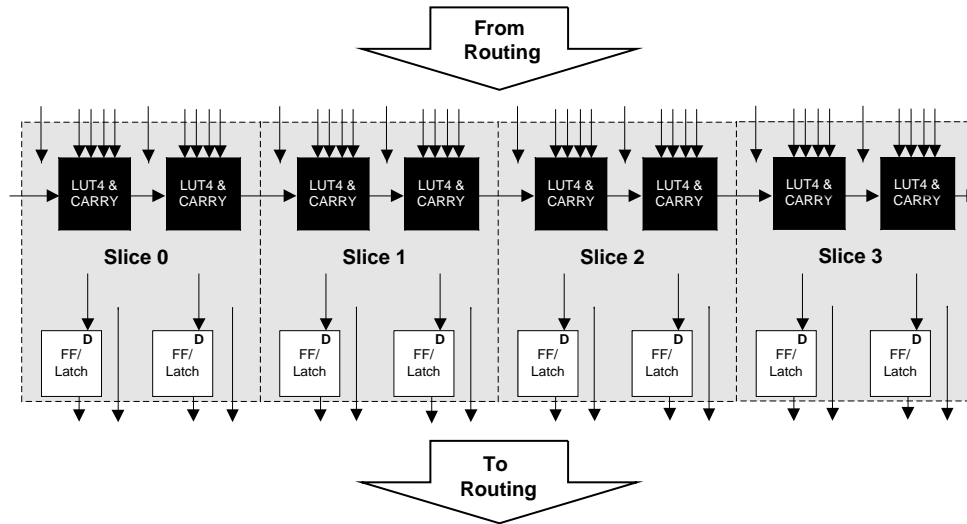

## Slice

Each slice contains two LUT4 lookup tables feeding two registers (programmed to be in FF or Latch mode), and some associated logic that allows the LUTs to be combined to perform functions such as LUT5, LUT6, LUT7 and LUT8. There is control logic to perform set/reset functions (programmable as synchronous/asynchronous), clock select, chip-select and wider RAM/ROM functions. Figure 2-4 shows an overview of the internal logic of the slice. The registers in the slice can be configured for positive/negative and edge/level clocks.

There are 14 input signals: 13 signals from routing and one from the carry-chain (from adjacent slice or PFU). There are 7 outputs: 6 to routing and one to carry-chain (to adjacent PFU). Table 2-1 lists the signals associated with each slice.

Figure 2-4. Slice Diagram

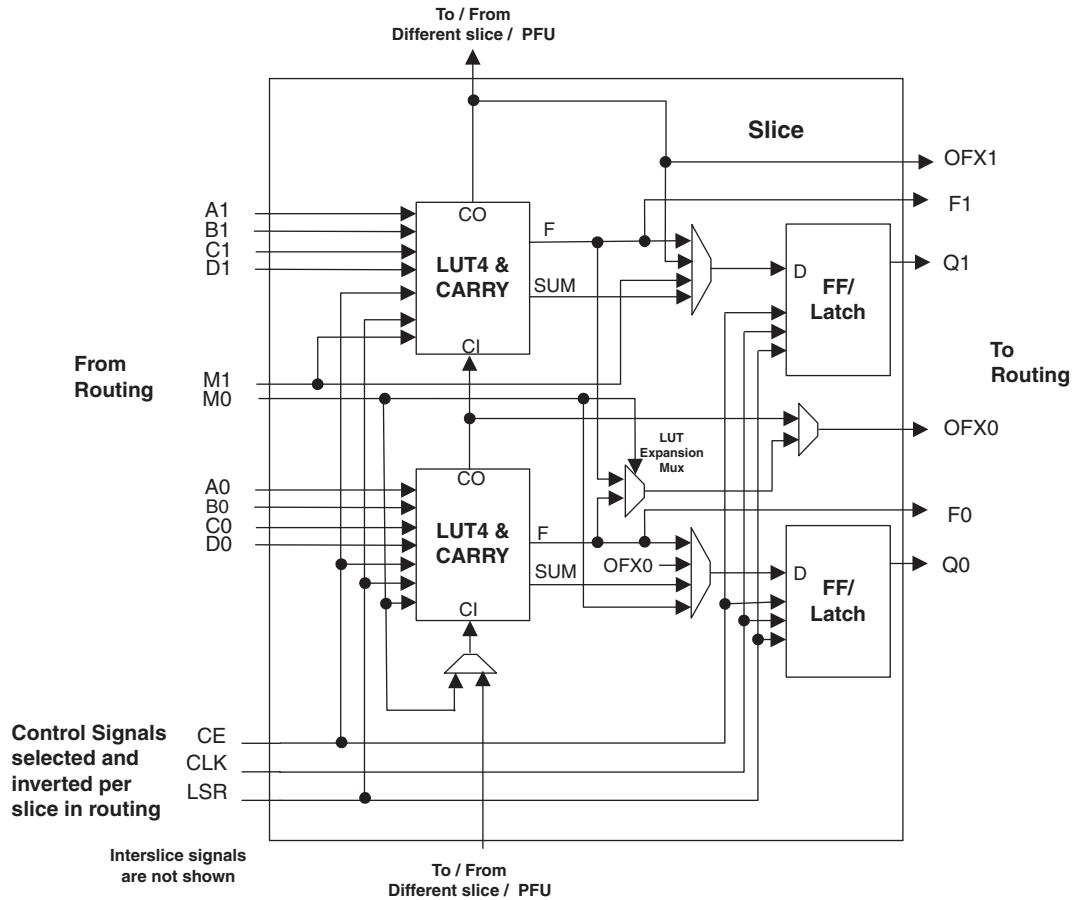

Table 2-1. Slice Signal Descriptions

Function	Type	Signal Names	Description
Input	Data signal	A0, B0, C0, D0	Inputs to LUT4
Input	Data signal	A1, B1, C1, D1	Inputs to LUT4
Input	Multi-purpose	M0	Multipurpose Input
Input	Multi-purpose	M1	Multipurpose Input
Input	Control signal	CE	Clock Enable
Input	Control signal	LSR	Local Set/Reset
Input	Control signal	CLK	System Clock
Input	Inter-PFU signal	FCIN	Fast Carry In <sup>1</sup>
Output	Data signals	F0, F1	LUT4 output register bypass signals
Output	Data signals	Q0, Q1	Register Outputs
Output	Data signals	OFX0	Output of a LUT5 MUX
Output	Data signals	OFX1	Output of a LUT6, LUT7, LUT8 <sup>2</sup> MUX depending on the slice
Output	Inter-PFU signal	FCO	For the right most PFU the fast carry chain output <sup>1</sup>

1. See Figure 2-3 for connection details.

2. Requires two PFUs.

**Modes of Operation**

Each Slice is capable of four modes of operation: Logic, Ripple, RAM and ROM. The Slice in the PFF is capable of all modes except RAM. Table 2-2 lists the modes and the capability of the Slice blocks.

**Table 2-2. Slice Modes**

	Logic	Ripple	RAM	ROM
PFU Slice	LUT 4x2 or LUT 5x1	2-bit Arithmetic Unit	SPR16x2	ROM16x1 x 2
PFF Slice	LUT 4x2 or LUT 5x1	2-bit Arithmetic Unit	N/A	ROM16x1 x 2

**Logic Mode:** In this mode, the LUTs in each Slice are configured as 4-input combinatorial lookup tables. A LUT4 can have 16 possible input combinations. Any logic function with four inputs can be generated by programming this lookup table. Since there are two LUT4s per Slice, a LUT5 can be constructed within one Slice. Larger lookup tables such as LUT6, LUT7 and LUT8 can be constructed by concatenating other Slices.

**Ripple Mode:** Ripple mode allows the efficient implementation of small arithmetic functions. In ripple mode, the following functions can be implemented by each Slice:

- Addition 2-bit
- Subtraction 2-bit
- Add/Subtract 2-bit using dynamic control
- Up counter 2-bit
- Down counter 2-bit
- Ripple mode multiplier building block
- Comparator functions of A and B inputs
  - A greater-than-or-equal-to B
  - A not-equal-to B
  - A less-than-or-equal-to B

Ripple Mode includes an optional configuration that performs arithmetic using fast carry chain methods. In this configuration (also referred to as CCU2 mode) two additional signals, Carry Generate and Carry Propagate, are generated on a per slice basis to allow fast arithmetic functions to be constructed by concatenating Slices.

**RAM Mode:** In this mode, distributed RAM can be constructed using each LUT block as a 16x1-bit memory. Through the combination of LUTs and Slices, a variety of different memories can be constructed.

The Lattice design tools support the creation of a variety of different size memories. Where appropriate, the software will construct these using distributed memory primitives that represent the capabilities of the PFU. Table 2-3 shows the number of Slices required to implement different distributed RAM primitives. Figure 2-5 shows the distributed memory primitive block diagrams. Dual port memories involve the pairing of two Slices, one Slice functions as the read-write port. The other companion Slice supports the read-only port. For more information about using RAM in LatticeECP/EC devices, please see the list of technical documentation at the end of this data sheet.

**Table 2-3. Number of Slices Required For Implementing Distributed RAM**

	SPR16x2	DPR16x2
Number of slices	1	2

Note: SPR = Single Port RAM, DPR = Dual Port RAM



Figure 2-5. Distributed Memory Primitives

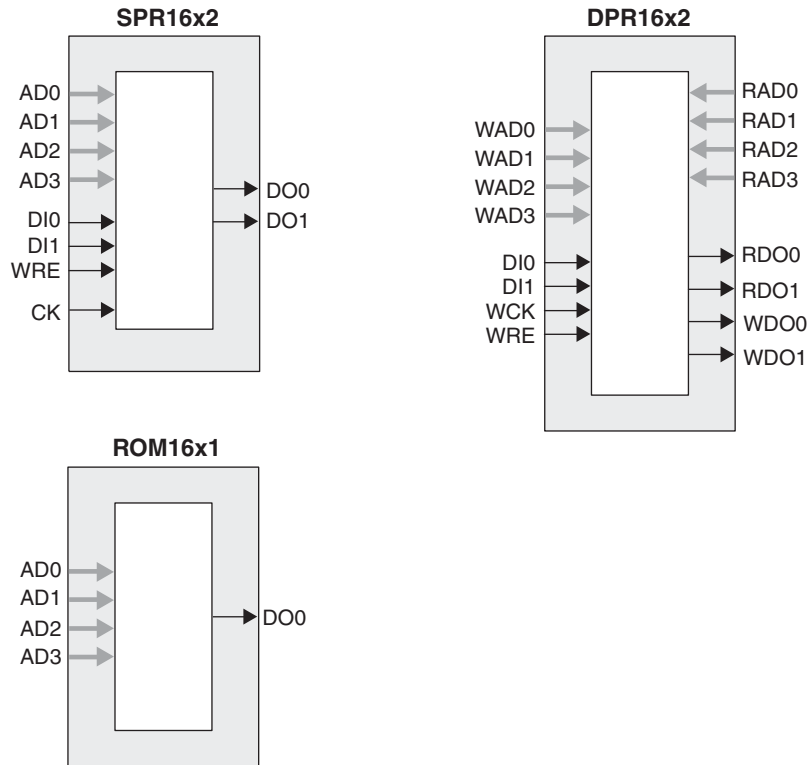

**ROM Mode:** The ROM mode uses the same principal as the RAM modes, but without the Write port. Pre-loading is accomplished through the programming interface during configuration.

**PFU Modes of Operation**

Slices can be combined within a PFU to form larger functions. Table 2-4 tabulates these modes and documents the functionality possible at the PFU level.

Table 2-4. PFU Modes of Operation

Logic	Ripple	RAM <sup>1</sup>	ROM
LUT 4x8 or MUX 2x1 x 8	2-bit Add x 4	SPR16x2 x 4 DPR16x2 x 2	ROM16x1 x 8
LUT 5x4 or MUX 4x1 x 4	2-bit Sub x 4	SPR16x4 x 2 DPR16x4 x 1	ROM16x2 x 4
LUT 6x 2 or MUX 8x1 x 2	2-bit Counter x 4	SPR16x8 x 1	ROM16x4 x 2
LUT 7x1 or MUX 16x1 x 1	2-bit Comp x 4		ROM16x8 x 1

1. These modes are not available in PFF blocks

## Routing

There are many resources provided in the LatticeECP/EC devices to route signals individually or as busses with related control signals. The routing resources consist of switching circuitry, buffers and metal interconnect (routing) segments.

The inter-PFU connections are made with x1 (spans two PFU), x2 (spans three PFU) and x6 (spans seven PFU). The x1 and x2 connections provide fast and efficient connections in horizontal and vertical directions. The x2 and x6 resources are buffered, the routing of both short and long connections between PFUs.

The ispLEVER design tool suite takes the output of the synthesis tool and places and routes the design. Generally, the place and route tool is completely automatic, although an interactive routing editor is available to optimize the design.

## Clock Distribution Network

The clock inputs are selected from external I/O, the sysCLOCK™ PLLs or routing. These clock inputs are fed through the chip via a clock distribution system.

### Primary Clock Sources

LatticeECP/EC devices derive clocks from three primary sources: PLL outputs, dedicated clock inputs and routing. LatticeECP/EC devices have two to four sysCLOCK PLLs, located on the left and right sides of the device. There are four dedicated clock inputs, one on each side of the device. Figure 2-6 shows the 20 primary clock sources.

**Figure 2-6. Primary Clock Sources**

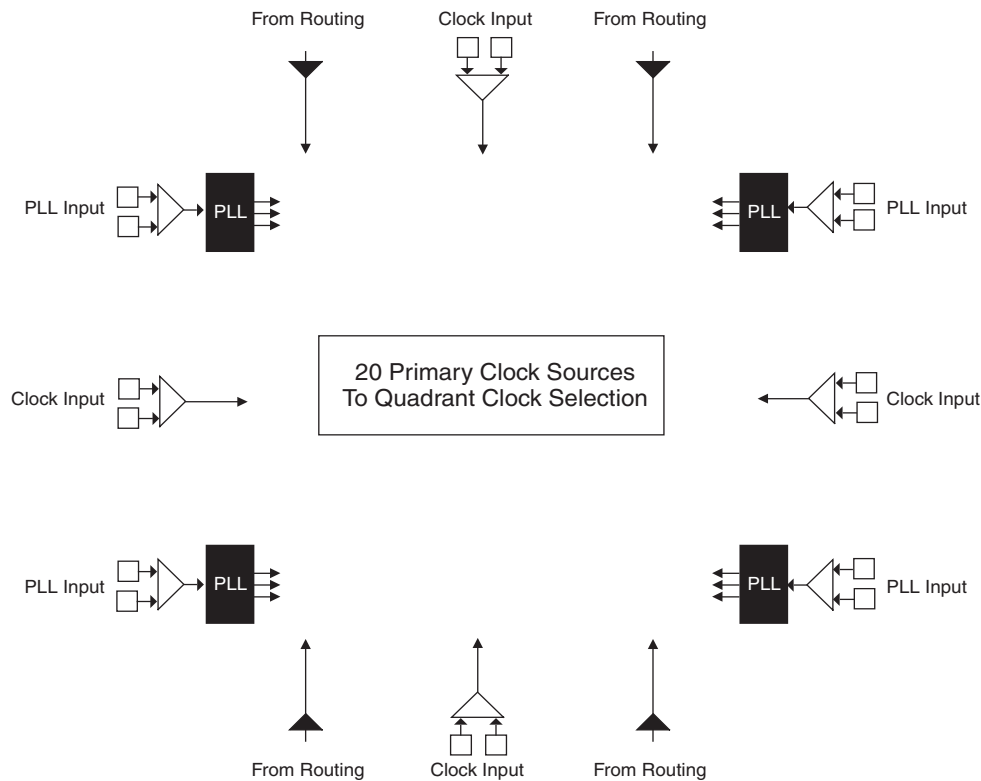

Note: Smaller devices have two PLLs.

### Secondary Clock Sources

LatticeECP/EC devices have four secondary clock resources per quadrant. The secondary clock branches are tapped at every PFU. These secondary clock networks can also be used for controls and high fanout data. These secondary clocks are derived from four clock input pads and 16 routing signals as shown in Figure 2-7.

**Figure 2-7. Secondary Clock Sources**

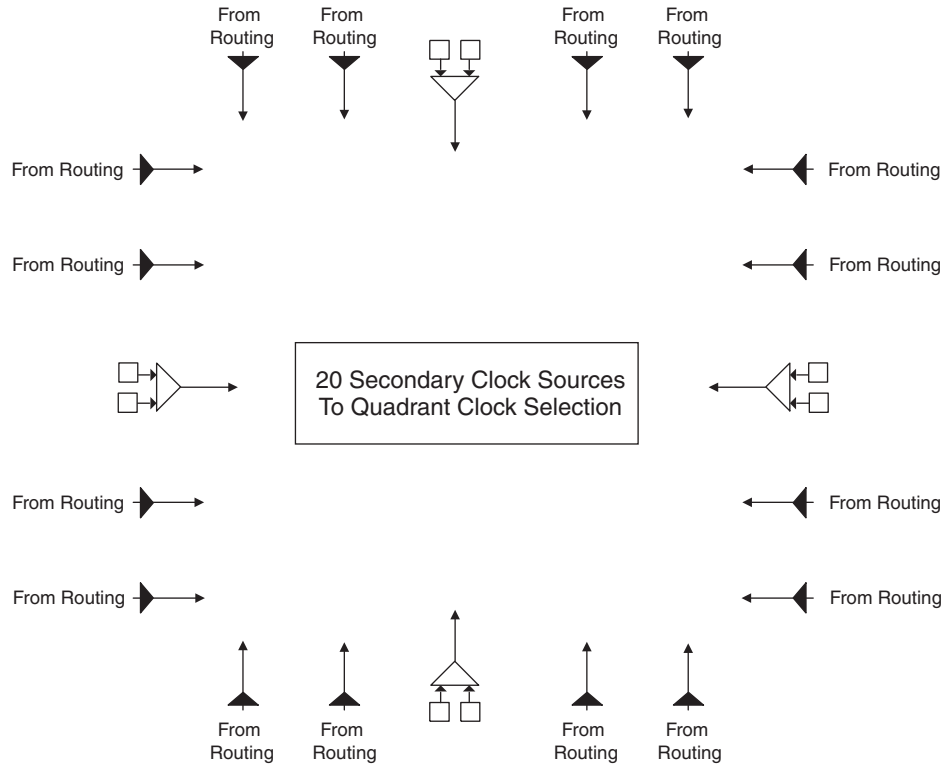

### Clock Routing

The clock routing structure in LatticeECP/EC devices consists of four Primary Clock lines and a Secondary Clock network per quadrant. The primary clocks are generated from MUXs located in each quadrant. Figure 2-8 shows this clock routing. The four secondary clocks are generated from MUXs located in each quadrant as shown in Figure 2-9. Each slice derives its clock from the primary clock lines, secondary clock lines and routing as shown in Figure 2-10.

**Figure 2-8. Per Quadrant Primary Clock Selection**

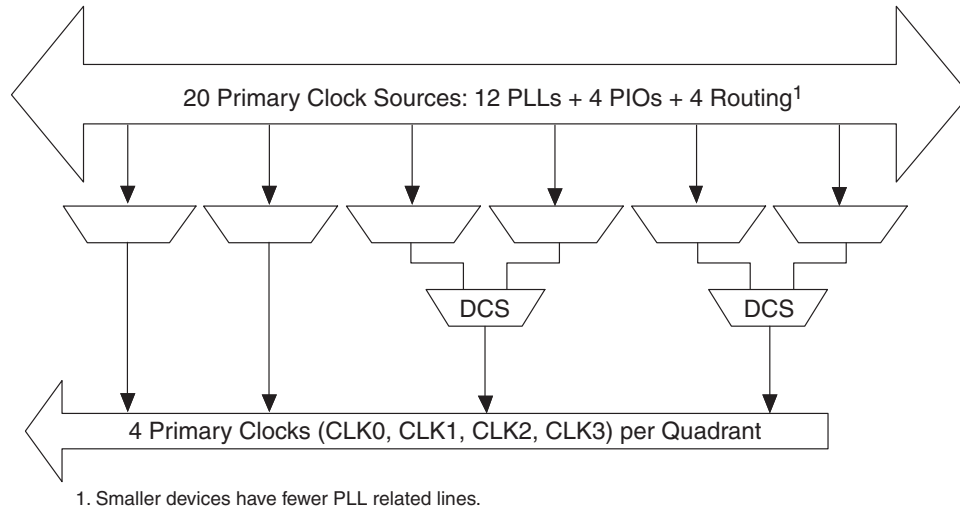

**Figure 2-9. Per Quadrant Secondary Clock Selection**

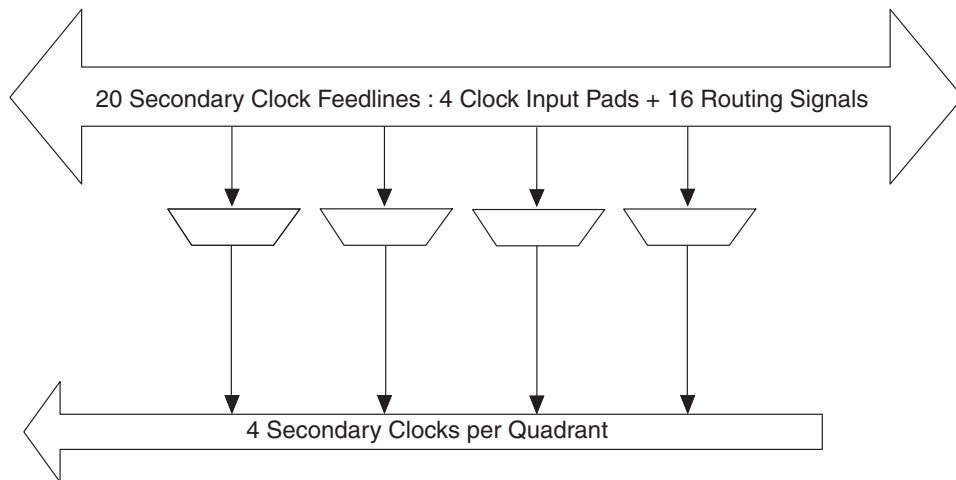

**Figure 2-10. Slice Clock Selection**

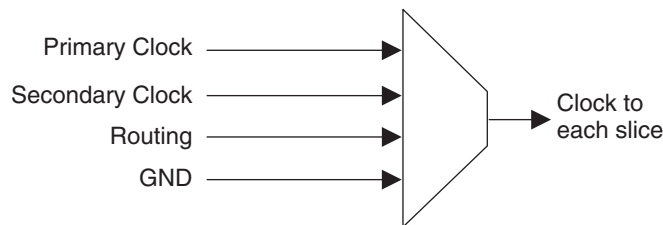

**sysCLOCK Phase Locked Loops (PLLs)**

The PLL clock input, from pin or routing, feeds into an input clock divider. There are three sources of feedback signal to the feedback divider: from CLKOP (PLL Internal), from clock net (CLKOP) or from a user clock (PIN or logic). There is a PLL\_LOCK signal to indicate that VCO has locked on to the input clock signal. Figure 2-11 shows the sysCLOCK PLL diagram.

The setup and hold times of the device can be improved by programming a delay in the feedback or input path of the PLL which will advance or delay the output clock with reference to the input clock. This delay can be either pro-

grammed during configuration or can be adjusted dynamically. In dynamic mode, the PLL may lose lock after adjustment and not relock until the  $t_{LOCK}$  parameter has been satisfied. Additionally, the phase and duty cycle block allows the user to adjust the phase and duty cycle of the CLKOS output.

The sysCLOCK PLLs provide the ability to synthesize clock frequencies. Each PLL has four dividers associated with it: input clock divider, feedback divider, post scalar divider and secondary clock divider. The input clock divider is used to divide the input clock signal, while the feedback divider is used to multiply the input clock signal. The post scalar divider allows the VCO to operate at higher frequencies than the clock output, thereby increasing the frequency range. The secondary divider is used to derive lower frequency outputs.

Figure 2-11. PLL Diagram

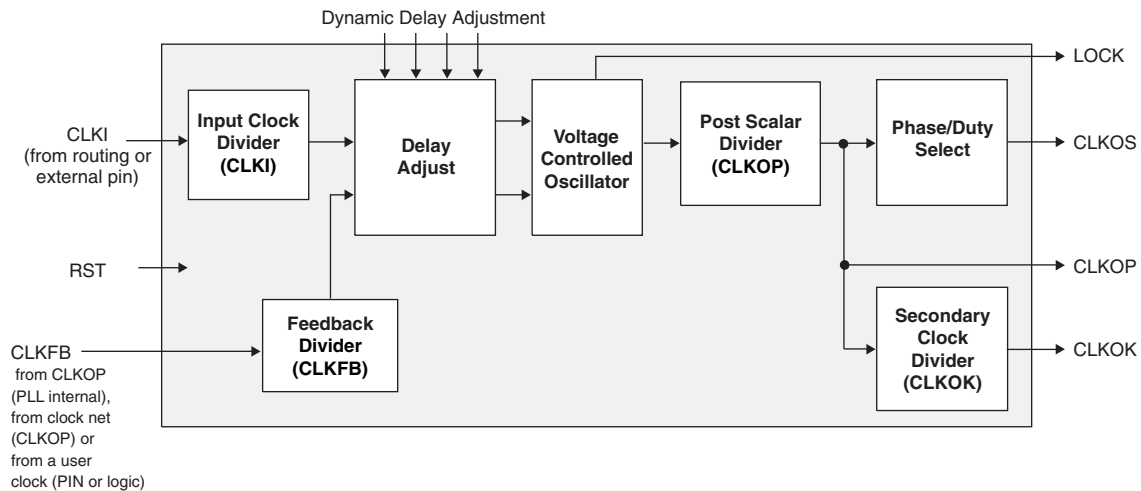
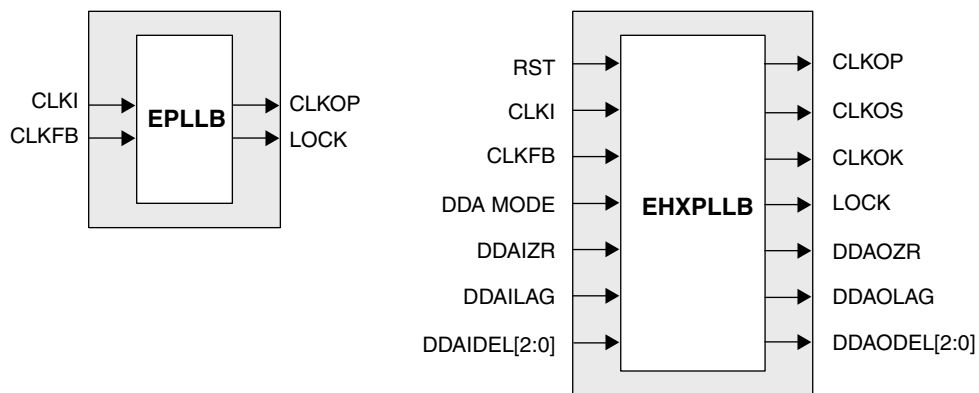

Figure 2-12 shows the available macros for the PLL. Table 2-5 provides signal description of the PLL Block.

Figure 2-12. PLL Primitive



**Table 2-5. PLL Signal Descriptions**

Signal	I/O	Description
CLKI	I	Clock input from external pin or routing
CLKFB	I	PLL feedback input from CLKOP (PLL internal), from clock net (CLKOP) or from a user clock (PIN or logic)
RST	I	"1" to reset PLL
CLKOS	O	PLL output clock to clock tree (phase shifted/duty cycle changed)
CLKOP	O	PLL output clock to clock tree (No phase shift)
CLKOK	O	PLL output to clock tree through secondary clock divider
LOCK	O	"1" indicates PLL LOCK to CLKI
DDAMODE	I	Dynamic Delay Enable. "1": Pin control (dynamic), "0": Fuse Control (static)
DDAIZR	I	Dynamic Delay Zero. "1": delay = 0, "0": delay = on
DDAILAG	I	Dynamic Delay Lag/Lead. "1": Lead, "0": Lag
DDAIDEL[2:0]	I	Dynamic Delay Input
DDAOZR	O	Dynamic Delay Zero Output
DDAOLAG	O	Dynamic Delay Lag/Lead Output
DDAODEL[2:0]	O	Dynamic Delay Output

For more information about the PLL, please see the list of technical documentation at the end of this data sheet.

## Dynamic Clock Select (DCS)

The DCS is a global clock buffer with smart multiplexer functions. It takes two independent input clock sources and outputs a clock signal without any glitches or runt pulses. This is achieved regardless of where the select signal is toggled. There are eight DCS blocks per device, located in pairs at the center of each side. Figure 2-13 illustrates the DCS Block Macro.

**Figure 2-13. DCS Block Primitive**

Figure 2-14 shows timing waveforms of the default DCS operating mode. The DCS block can be programmed to other modes. For more information about the DCS, please see the list of technical documentation at the end of this data sheet.

Figure 2-14. DCS Waveforms

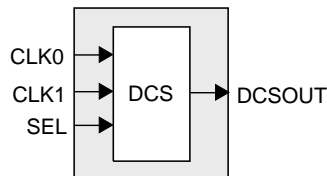
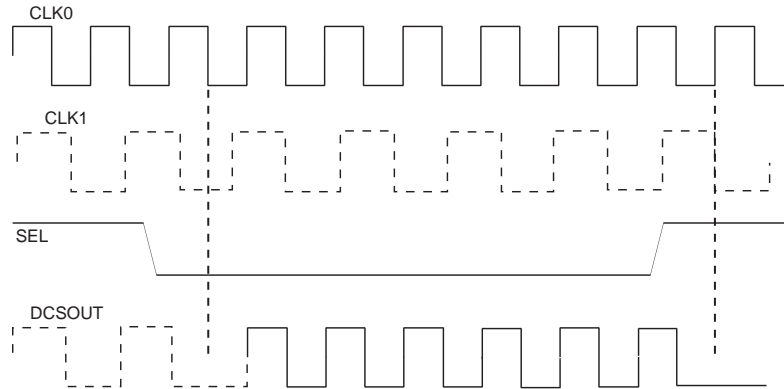

### sysMEM Memory

The LatticeECP/EC devices contain a number of sysMEM Embedded Block RAM (EBR). The EBR consists of a 9-Kbit RAM, with dedicated input and output registers.

### sysMEM Memory Block

The sysMEM block can implement single port, dual port or pseudo dual port memories. Each block can be used in a variety of depths and widths as shown in Table 2-6.

Table 2-6. sysMEM Block Configurations

Memory Mode	Configurations
Single Port	8,192 x 1
	4,096 x 2
	2,048 x 4
	1,024 x 9
	512 x 18
	256 x 36
True Dual Port	8,192 x 1
	4,096 x 2
	2,048 x 4
	1,024 x 9
	512 x 18
Pseudo Dual Port	8,192 x 1
	4,096 x 2
	2,048 x 4
	1,024 x 9
	512 x 18
	256 x 36

### Bus Size Matching

All of the multi-port memory modes support different widths on each of the ports. The RAM bits are mapped LSB word 0 to MSB word 0, LSB word 1 to MSB word 1 and so on. Although the word size and number of words for each port varies, this mapping scheme applies to each port.

### RAM Initialization and ROM Operation

If desired, the contents of the RAM can be pre-loaded during device configuration. By preloading the RAM block during the chip configuration cycle and disabling the write controls, the sysMEM block can also be utilized as a ROM.

## Memory Cascading

Larger and deeper blocks of RAM can be created using EBR sysMEM Blocks. Typically, the Lattice design tools cascade memory transparently, based on specific design inputs.

## Single, Dual and Pseudo-Dual Port Modes

Figure 2-15 shows the four basic memory configurations and their input/output names. In all the sysMEM RAM modes the input data and address for the ports are registered at the input of the memory array. The output data of the memory is optionally registered at the output.

Figure 2-15. sysMEM EBR Primitives

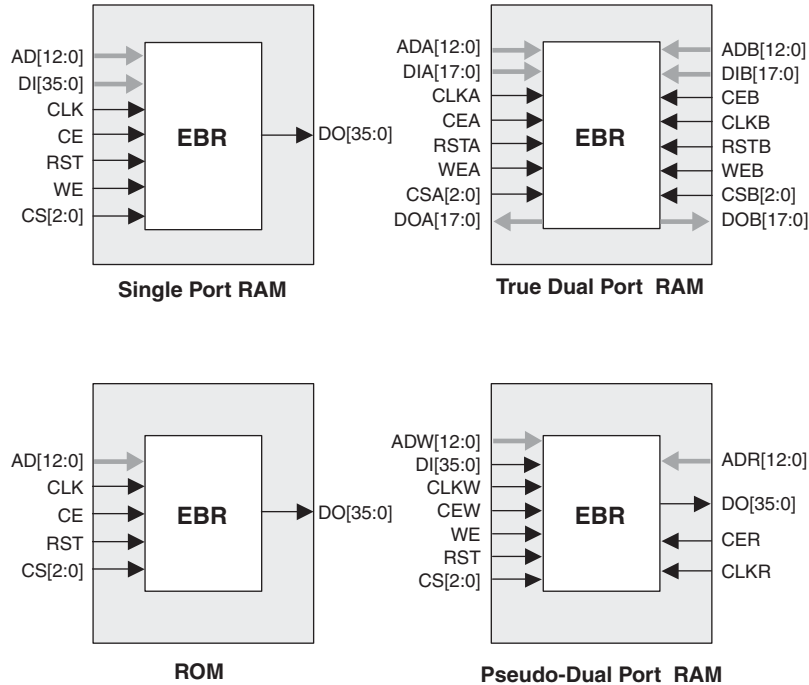

The EBR memory supports three forms of write behavior for single port or dual port operation:

1. **Normal** – data on the output appears only during read cycle. During a write cycle, the data (at the current address) does not appear on the output. This mode is supported for all data widths.
2. **Write Through** – a copy of the input data appears at the output of the same port during a write cycle. This mode is supported for all data widths.
3. **Read-Before-Write** – when new data is being written, the old content of the address appears at the output. This mode is supported for x9, x18 and x36 data widths.

## Memory Core Reset

The memory array in the EBR utilizes latches at the A and B output ports. These latches can be reset asynchronously or synchronously. RSTA and RSTB are local signals, which reset the output latches associated with Port A and Port B, respectively. The Global Reset (GSRN) signal resets both ports. The output data latches and associated resets for both ports are as shown in Figure 2-16.



Figure 2-16. Memory Core Reset

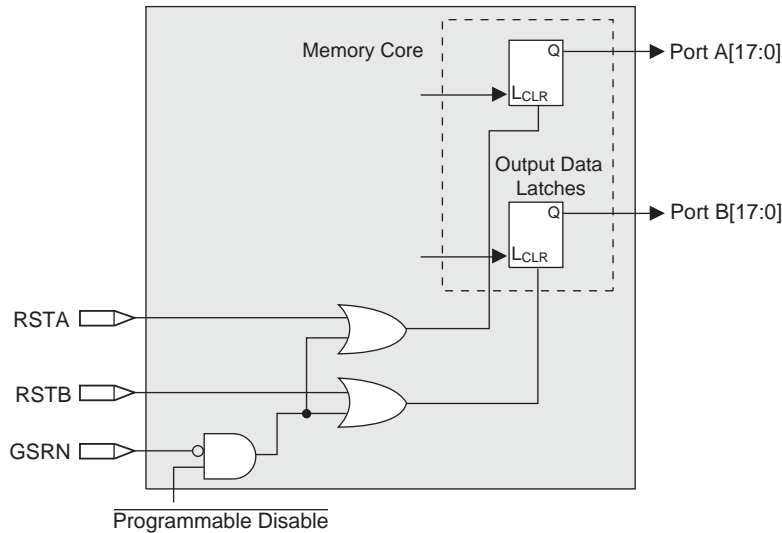

For further information about sysMEM EBR block, please see the the list of technical documentation at the end of this data sheet.

**EBR Asynchronous Reset**

EBR asynchronous reset or GSR (if used) can only be applied if all clock enables are low for a clock cycle before the reset is applied and released a clock cycle after the reset is released, as shown in Figure 2-17. The GSR input to the EBR is always asynchronous.

Figure 2-17. EBR Asynchronous Reset (Including GSR) Timing Diagram

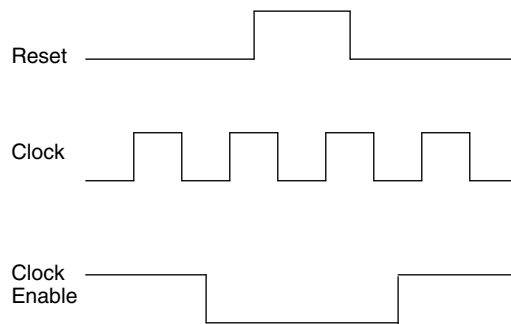

If all clock enables remain enabled, the EBR asynchronous reset or GSR may only be applied and released after the EBR read and write clock inputs are in a steady state condition for a minimum of  $1/f_{MAX}$  (EBR clock). The reset release must adhere to the EBR synchronous reset setup time before the next active read or write clock edge.

If an EBR is pre-loaded during configuration, the GSR input must be disabled or the release of the GSR during device Wake Up must occur before the release of the device I/Os becomes active.

These instructions apply to all EBR RAM and ROM implementations.

Note that there are no reset restrictions if the EBR synchronous reset is used and the EBR GSR input is disabled.

**sysDSP Block**

The LatticeECP-DSP family provides a sysDSP block, making it ideally suited for low cost, high performance Digital Signal Processing (DSP) applications. Typical functions used in these applications are Finite Impulse Response (FIR) filters; Fast Fourier Transforms (FFT) functions, correlators, Reed-Solomon/Turbo/Convolution encoders and

decoders. These complex signal processing functions use similar building blocks such as multiply-adders and multiply-accumulators.

### sysDSP Block Approach Compared to General DSP

Conventional general-purpose DSP chips typically contain one to four (Multiply and Accumulate) MAC units with fixed data-width multipliers; this leads to limited parallelism and limited throughput. Their throughput is increased by higher clock speeds. The LatticeECP, on the other hand, has many DSP blocks that support different data-widths. This allows the designer to use highly parallel implementations of DSP functions. The designer can optimize the DSP performance vs. area by choosing an appropriate level of parallelism. Figure 2-18 compares the serial and the parallel implementations.

**Figure 2-18. Comparison of General DSP and LatticeECP-DSP Approaches**

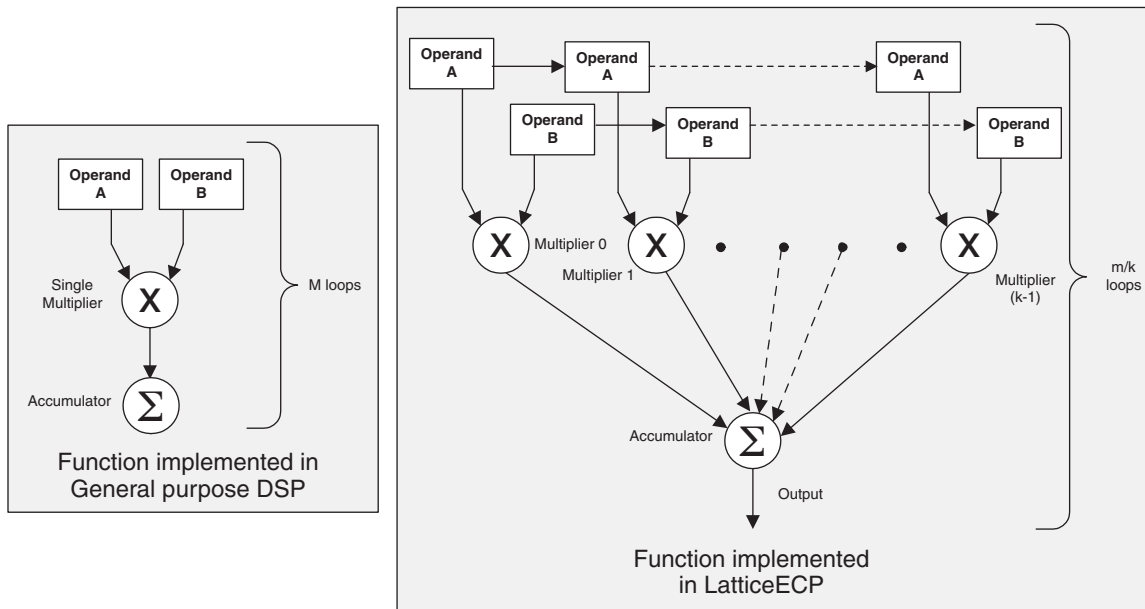

### sysDSP Block Capabilities

The sysDSP block in the LatticeECP-DSP family supports four functional elements in three 9, 18 and 36 data path widths. The user selects a function element for a DSP block and then selects the width and type (signed/unsigned) of its operands. The operands in the LatticeECP-DSP family sysDSP Blocks can be either signed or unsigned but not mixed within a function element. Similarly, the operand widths cannot be mixed within a block.

The resources in each sysDSP block can be configured to support the following four elements:

- MULT (Multiply)
- MAC (Multiply, Accumulate)
- MULTADD (Multiply, Addition/Subtraction)
- MULTADDSUM (Multiply, Addition/Subtraction, Accumulate)

The number of elements available in each block depends on the width selected from the three available options x9, x18, and x36. A number of these elements are concatenated for highly parallel implementations of DSP functions. Table 2-1 shows the capabilities of the block.

**Table 2-7. Maximum Number of Elements in a Block**

Width of Multiply	x9	x18	x36
MULT	8	4	1
MAC	2	2	—
MULTADD	4	2	—
MULTADDSUM	2	1	—

Some options are available in four elements. The input register in all the elements can be directly loaded or can be loaded as shift registers from previous operand registers. In addition by selecting “dynamic operation” in the ‘Signed/Unsigned’ options the operands can be switched between signed and unsigned on every cycle. Similarly by selecting ‘Dynamic operation’ in the ‘Add/Sub’ option the Accumulator can be switched between addition and subtraction on every cycle.

**MULT sysDSP Element**

This multiplier element implements a multiply with no addition or accumulator nodes. The two operands, A and B, are multiplied and the result is available at the output. The user can enable the input/output and pipeline registers. Figure 2-19 shows the MULT sysDSP element.

**Figure 2-19. MULT sysDSP Element**

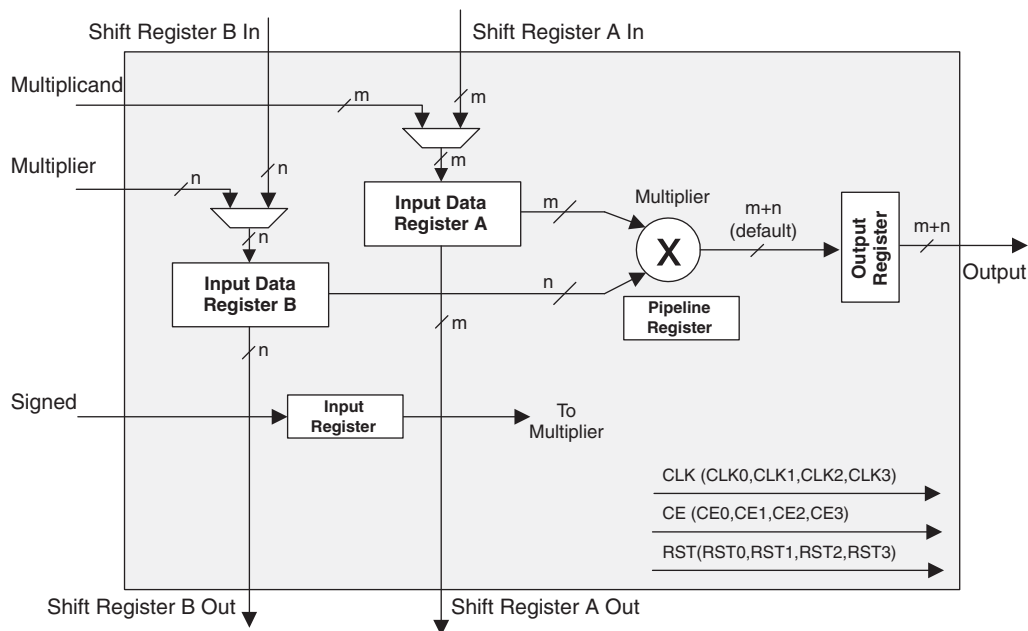

**MAC sysDSP Element**

In this case the two operands, A and B, are multiplied and the result is added with the previous accumulated value. This accumulated value is available at the output. The user can enable the input and pipeline registers but the output register is always enabled. The output register is used to store the accumulated value. A registered overflow signal is also available. The overflow conditions are provided later in this document. Figure 2-20 shows the MAC sysDSP element.

Figure 2-20. MAC sysDSP Element

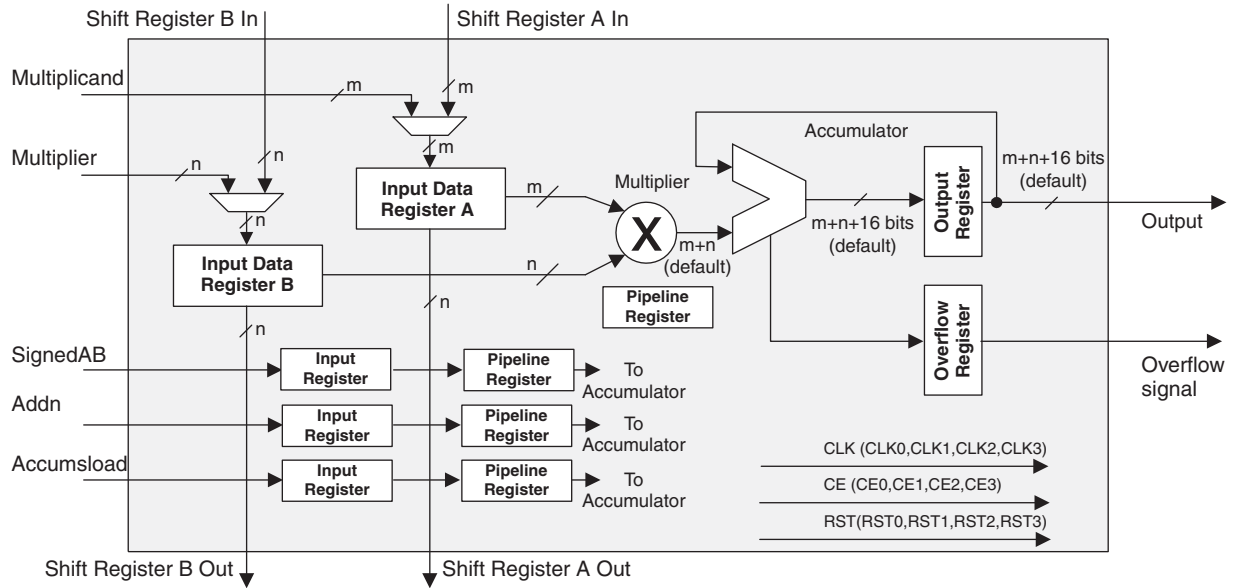

**MULTADD sysDSP Element**

In this case, the operands A0 and B0 are multiplied and the result is added/subtracted with the result of the multiplier operation of operands A1 and B1. The user can enable the input, output and pipeline registers. Figure 2-21 shows the MULTADD sysDSP element.

Figure 2-21. MULTADD

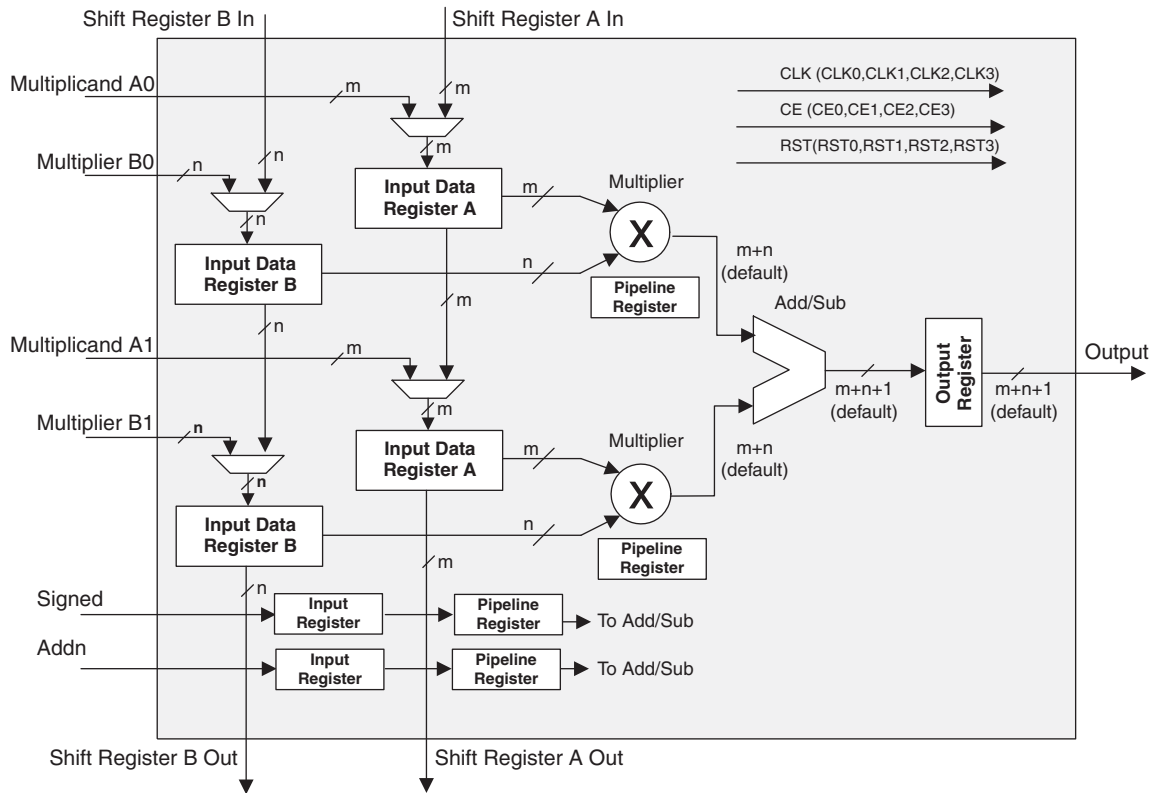

### MULTADDSUM sysDSP Element

In this case, the operands A0 and B0 are multiplied and the result is added/subtracted with the result of the multiplier operation of operands A1 and B1. Additionally the operands A2 and B2 are multiplied and the result is added/subtracted with the result of the multiplier operation of operands A3 and B3. The result of both addition/subtraction are added in a summation block. The user can enable the input, output and pipeline registers. Figure 2-22 shows the MULTADDSUM sysDSP element.

Figure 2-22. MULTADDSUM

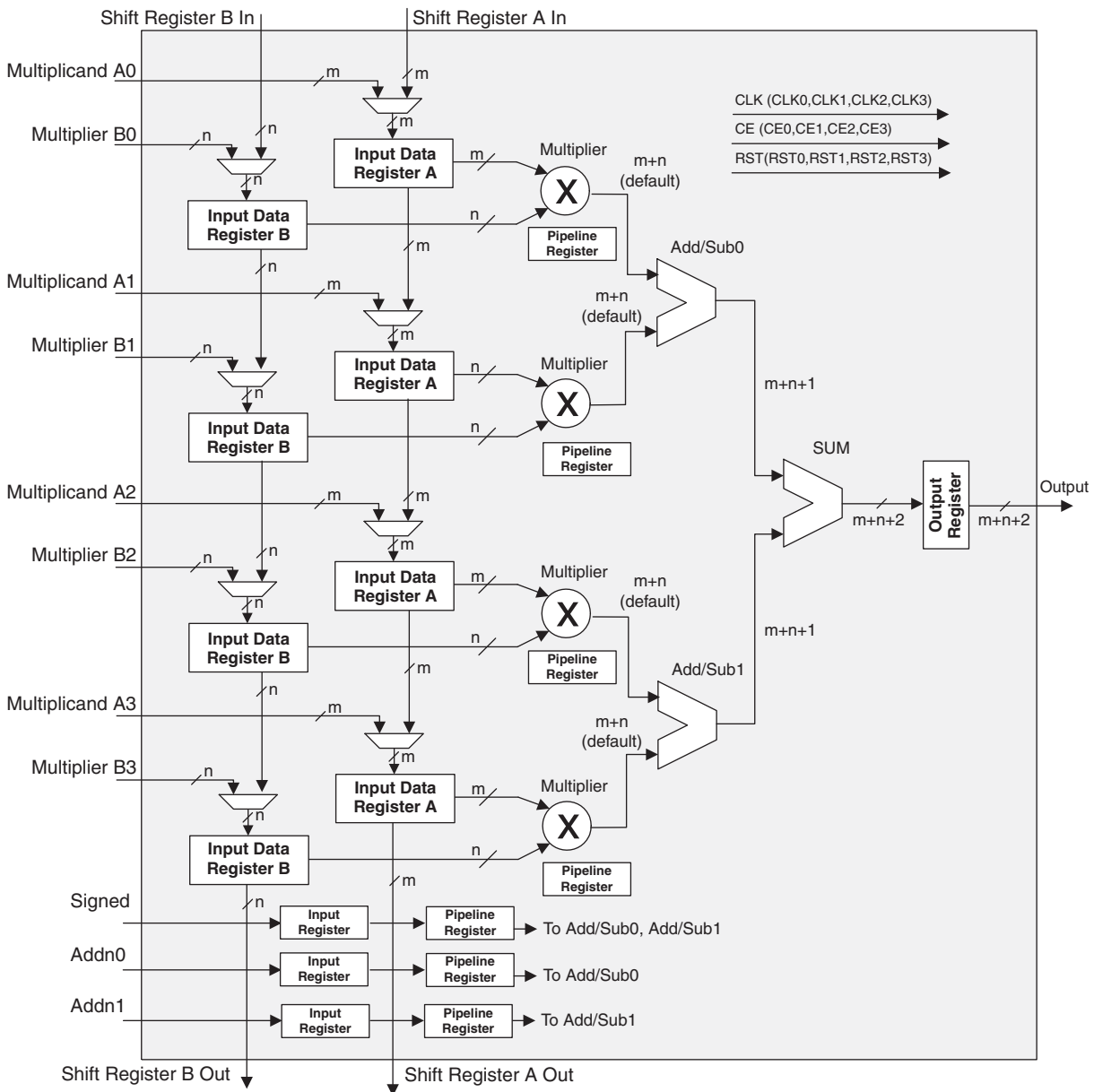

### Clock, Clock Enable and Reset Resources

Global Clock, Clock Enable and Reset signals from routing are available to every DSP block. Four Clock, Reset and Clock Enable signals are selected for the sysDSP block. From four clock sources (CLK0, CLK1, CLK2, CLK3) one clock is selected for each input register, pipeline register and output register. Similarly Clock enable (CE) and Reset (RST) are selected from their four respective sources (CE0, CE1, CE2, CE3 and RST0, RST1, RST2, RST3) at each input register, pipeline register and output register.

### Signed and Unsigned with Different Widths

The DSP block supports different widths of signed and unsigned multipliers besides x9, x18 and x36 widths. For unsigned operands, unused upper data bits should be filled to create a valid x9, x18 or x36 operand. For signed two's complement operands, sign extension of the most significant bit should be performed until x9, x18 or x36 width is reached. Table 2-8 provides an example of this.

**Table 2-8. An Example of Sign Extension**

Number	Unsigned	Unsigned 9-bit	Unsigned 18-bit	Signed	Two's Complement Signed 9-Bits	Two's Complement Signed 18-bits
+5	0101	000000101	0000000000000000101	0101	000000101	0000000000000000101
-6	0110	000000110	0000000000000000110	1010	11111010	111111111111111010

### OVERFLOW Flag from MAC

The sysDSP block provides an overflow output to indicate that the accumulator has overflowed. When two unsigned numbers are added and the result is a smaller number then accumulator roll over is said to occur and overflow signal is indicated. When two positive numbers are added with a negative sum and when two negative numbers are added with a positive sum, then the accumulator “roll-over” is said to have occurred and an overflow signal is indicated. Note when overflow occurs the overflow flag is present for only one cycle. By counting these overflow pulses in FPGA logic, larger accumulators can be constructed. The conditions overflow signals for signed and unsigned operands are listed in Figure 2-23.

**Figure 2-23. Accumulator Overflow/Underflow Conditions**

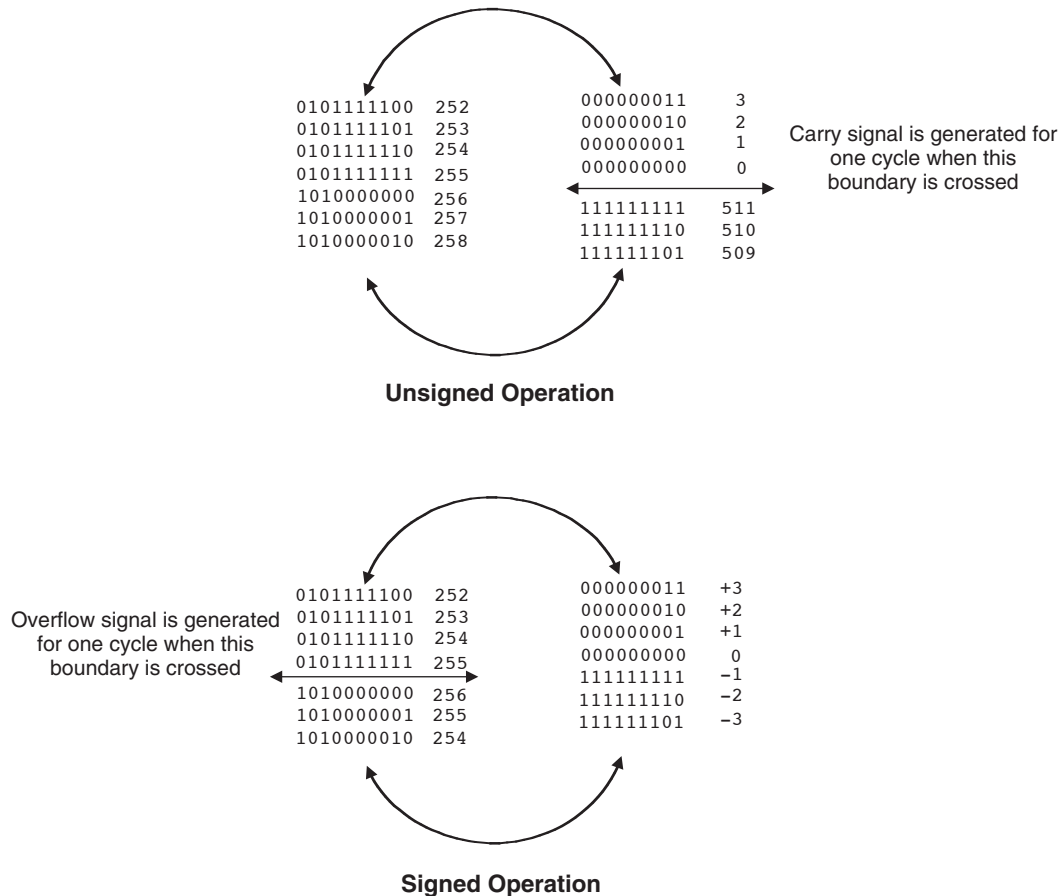

**IPexpress™**

The user can access the sysDSP block via the IPexpress configuration tool, included with the ispLEVER design tool suite. IPexpress has options to configure each DSP module (or group of modules) or through direct HDL instantiation. Additionally Lattice has partnered Mathworks to support instantiation in the Simulink tool, which is a Graphical Simulation Environment. Simulink works with ispLEVER and dramatically shortens the DSP design cycle in Lattice FPGAs.

**Optimized DSP Functions**

Lattice provides a library of optimized DSP IP functions. Some of the IPs planned for LatticeECP DSP are: Bit Correlators, Fast Fourier Transform, Finite Impulse Response (FIR) Filter, Reed-Solomon Encoder/ Decoder, Turbo Encoder/Decoders and Convolutional Encoder/Decoder. Please contact Lattice to obtain the latest list of available DSP IPs.

**Resources Available in the LatticeECP Family**

Table 2-9 shows the maximum number of multipliers for each member of the LatticeECP family. Table 2-10 shows the maximum available EBR RAM Blocks in each of the LatticeECP family. EBR blocks, together with Distributed RAM can be used to store variables locally for the fast DSP operations.

**Table 2-9. Number of DSP Blocks in LatticeECP Family**

Device	DSP Block	9x9 Multiplier	18x18 Multiplier	36x36 Multiplier
LFCEP6	4	32	16	4
LFCEP10	5	40	20	5
LFCEP15	6	48	24	6
LFCEP20	7	56	28	7
LFCEP33	8	64	32	8

**Table 2-10. Embedded SRAM in LatticeECP Family**

Device	EBR SRAM Block	Total EBR SRAM (Kbits)
LFCEP6	10	92
LFCEP10	30	276
LFCEP15	38	350
LFCEP20	46	424
LFCEP33	54	498

**DSP Performance of the LatticeECP Family**

Table 2-11 lists the maximum performance in millions of MAC operations per second (MMAC) for each member of the LatticeECP family.

**Table 2-11. DSP Block Performance of LatticeECP Family**

Device	DSP Block	DSP Performance MMAC
LFCEP6	4	3680
LFCEP10	5	4600
LFCEP15	6	5520
LFCEP20	7	6440
LFCEP33	8	7360

For further information about the sysDSP block, please see the list of technical information at the end of this data sheet.

### Programmable I/O Cells (PIC)

Each PIC contains two PIOs connected to their respective sysI/O Buffers which are then connected to the PADs as shown in Figure 2-24. The PIO Block supplies the output data (DO) and the Tri-state control signal (TO) to sysI/O buffer, and receives input from the buffer.

Figure 2-24. PIC Diagram

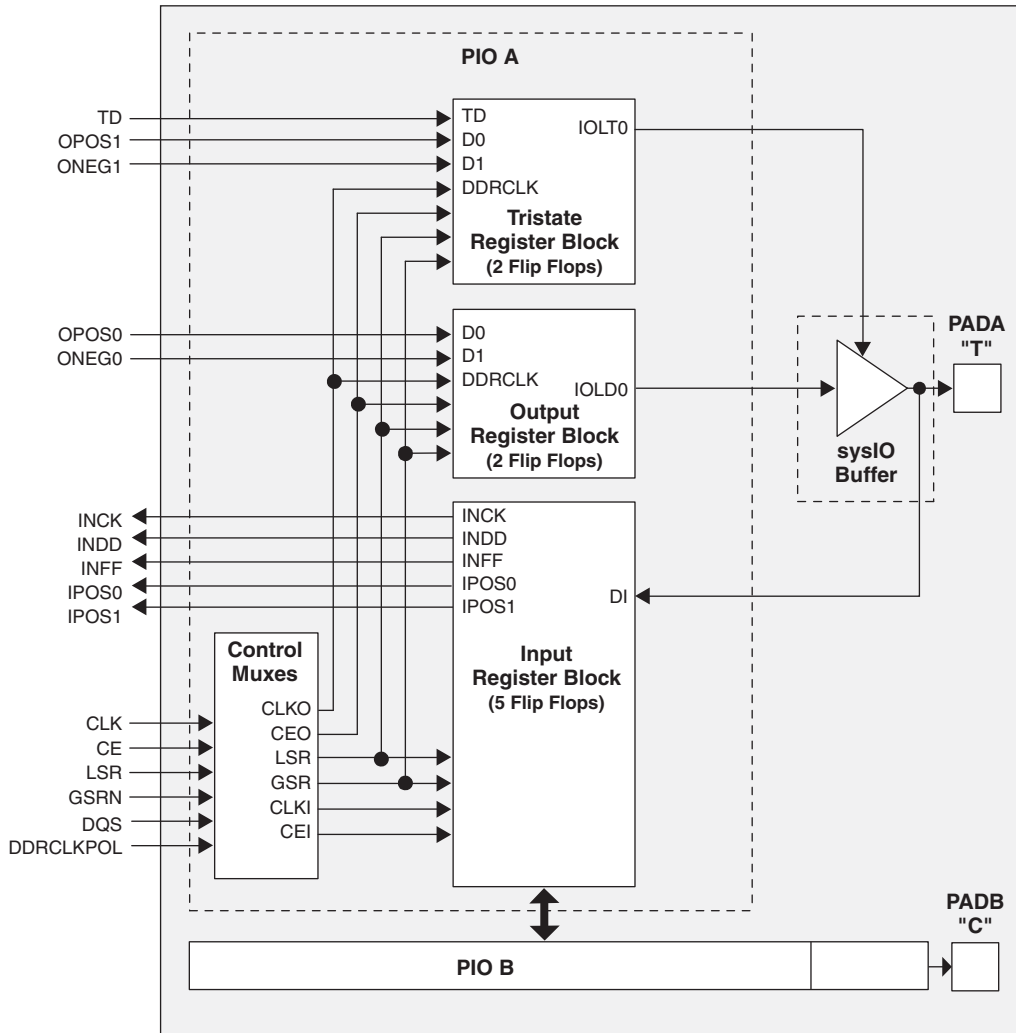

Two adjacent PIOs can be joined to provide a differential I/O pair (labeled as “T” and “C”) as shown in Figure 2-25. The PAD Labels “T” and “C” distinguish the two PIOs. Only the PIO pairs on the left and right edges of the device can be configured as LVDS transmit/receive pairs.

One of every 16 PIOs contains a delay element to facilitate the generation of DQS signals. The DQS signal feeds the DQS bus which spans the set of 16 PIOs. Figure 2-25 shows the assignment of DQS pins in each set of 16 PIOs. The exact DQS pins are shown in a dual function in the Logic Signal Connections table at the end of this data sheet. Additional detail is provided in the Signal Descriptions table at the end of this data sheet. The DQS signal from the bus is used to strobe the DDR data from the memory into input register blocks. This interface is designed for memories that support one DQS strobe per eight bits of data.



Table 2-12. PIO Signal List

Name	Type	Description
CE0, CE1	Control from the core	Clock enables for input and output block FFs.
CLK0, CLK1	Control from the core	System clocks for input and output blocks.
LSR	Control from the core	Local Set/Reset.
GSRN	Control from routing	Global Set/Reset (active low).
INCK	Input to the core	Input to Primary Clock Network or PLL reference inputs.
DQS	Input to PIO	DQS signal from logic (routing) to PIO.
INDD	Input to the core	Unregistered data input to core.
INFF	Input to the core	Registered input on positive edge of the clock (CLK0).
IPOS0, IPOS1	Input to the core	DDR <sub>X</sub> registered inputs to the core.
ONEG0	Control from the core	Output signals from the core for SDR and DDR operation.
OPOS0,	Control from the core	Output signals from the core for DDR operation
OPOS1 ONEG1	Tristate control from the core	Signals to Tristate Register block for DDR operation.
TD	Tristate control from the core	Tristate signal from the core used in SDR operation.
DDRCLKPOL	Control from clock polarity bus	Controls the polarity of the clock (CLK0) that feed the DDR input block.

Figure 2-25. DQS Routing

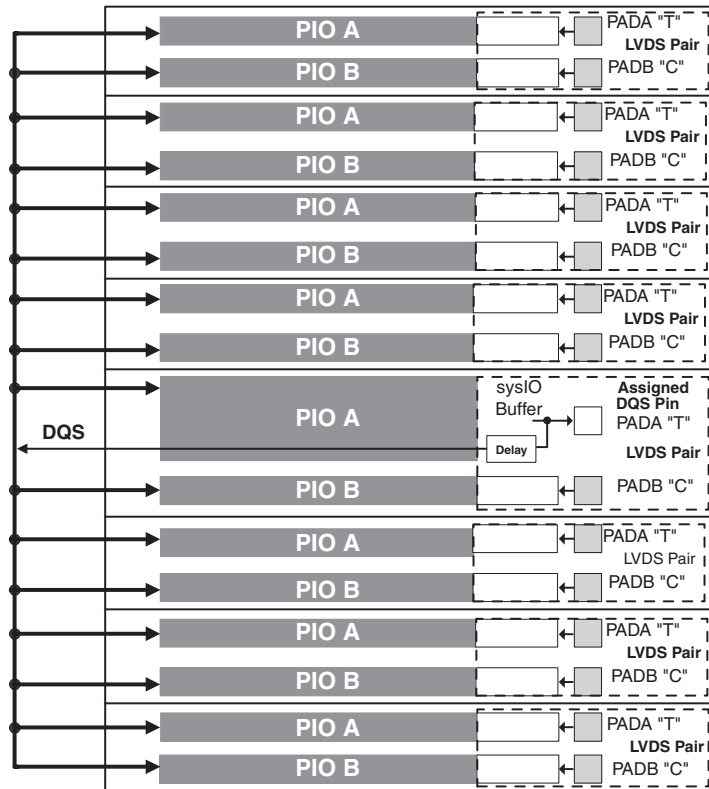

**PIO**

The PIO contains four blocks: an input register block, output register block, tristate register block and a control logic block. These blocks contain registers for both single data rate (SDR) and double data rate (DDR) operation along with the necessary clock and selection logic. Programmable delay lines used to shift incoming clock and data signals are also included in these blocks.

**Input Register Block**

The input register block contains delay elements and registers that can be used to condition signals before they are passed to the device core. Figure 2-26 shows the diagram of the input register block.

Input signals are fed from the sysI/O buffer to the input register block (as signal DI). If desired the input signal can bypass the register and delay elements and be used directly as a combinatorial signal (INDD), a clock (INCK) and in selected blocks the input to the DQS delay block. If one of the bypass options is not chosen, the signal first passes through an optional delay block. This delay, if selected, reduces input-register hold-time requirement when using a global clock.

The input block allows two modes of operation. In the single data rate (SDR) the data is registered, by one of the registers in the single data rate sync register block, with the system clock. In the DDR Mode two registers are used to sample the data on the positive and negative edges of the DQS signal creating two data streams, D0 and D2. These two data streams are synchronized with the system clock before entering the core. Further discussion on this topic is in the DDR Memory section of this data sheet.

Figure 2-27 shows the input register waveforms for DDR operation and Figure 2-28 shows the design tool primitives. The SDR/SYNC registers have reset and clock enable available.

The signal DDRCLKPOL controls the polarity of the clock used in the synchronization registers. It ensures adequate timing when data is transferred from the DQS to system clock domain. For further discussion on this topic, see the DDR Memory section of this data sheet.

**Figure 2-26. Input Register Diagram**

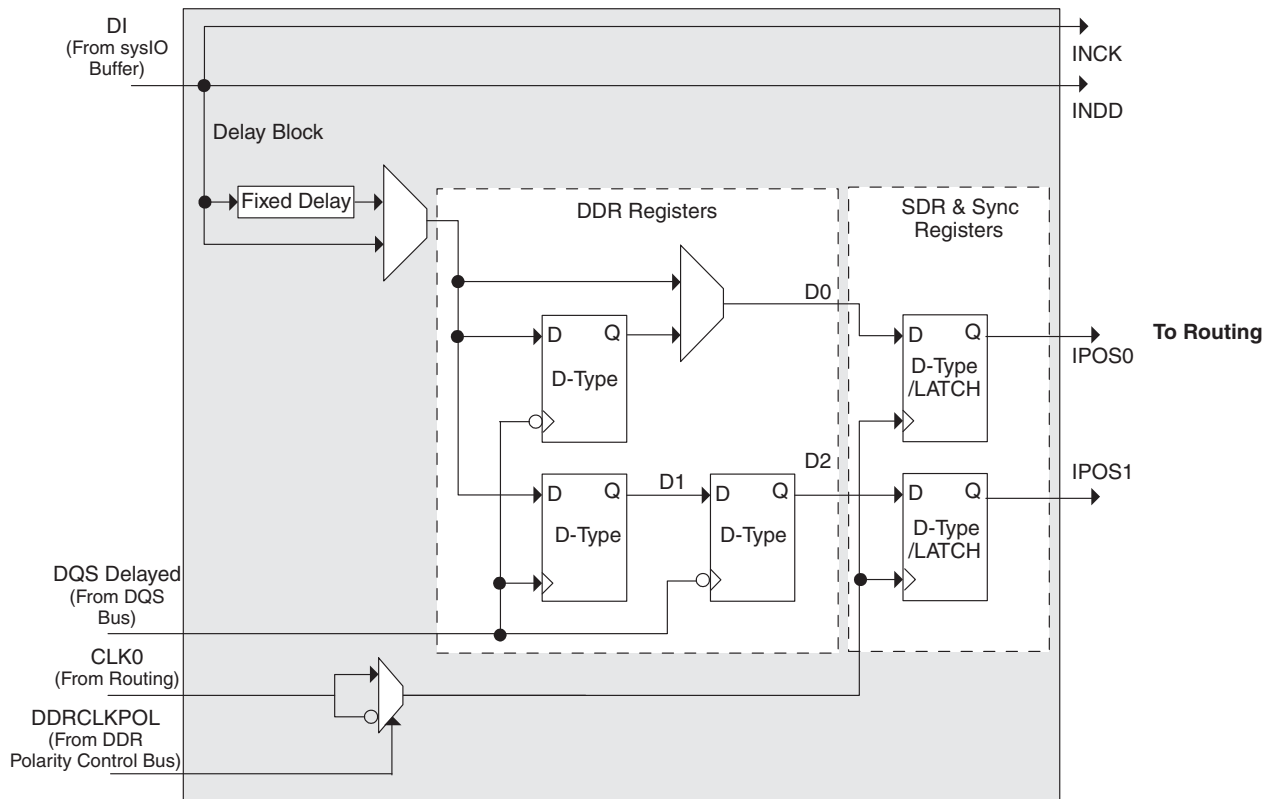

Figure 2-27. Input Register DDR Waveforms

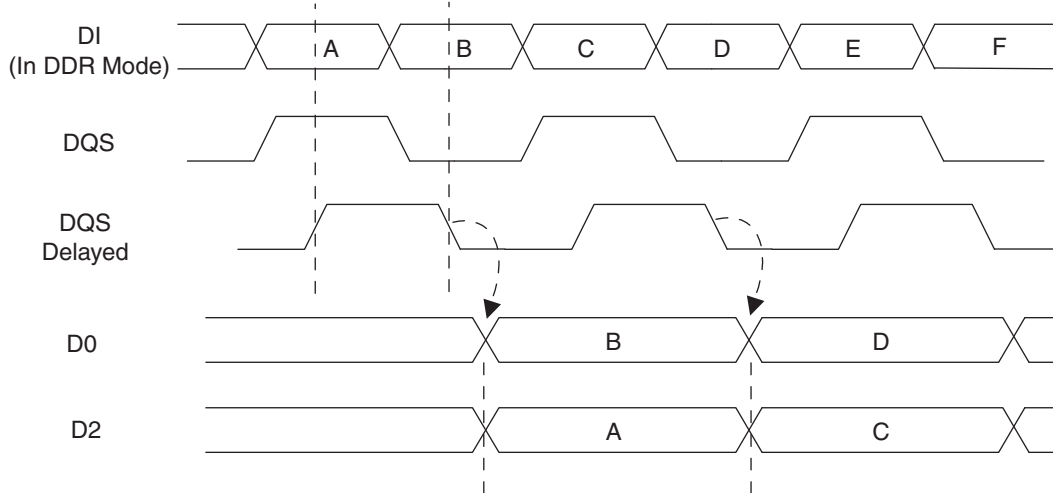
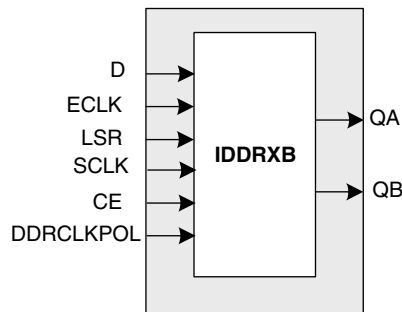

Figure 2-28. INDDRXB Primitive



**Output Register Block**

The output register block provides the ability to register signals from the core of the device before they are passed to the sysI/O buffers. The block contains a register for SDR operation that is combined with an additional latch for DDR operation. Figure 2-29 shows the diagram of the Output Register Block.

In SDR mode, ONEG0 feeds one of the flip-flops that then feeds the output. The flip-flop can be configured a D-type or latch. In DDR mode, ONEG0 is fed into one register on the positive edge of the clock and OPOS0 is latched. A multiplexer running off the same clock selects the correct register for feeding to the output (D0).

Figure 2-30 shows the design tool DDR primitives. The SDR output register has reset and clock enable available. The additional register for DDR operation does not have reset or clock enable available.

Figure 2-29. Output Register Block

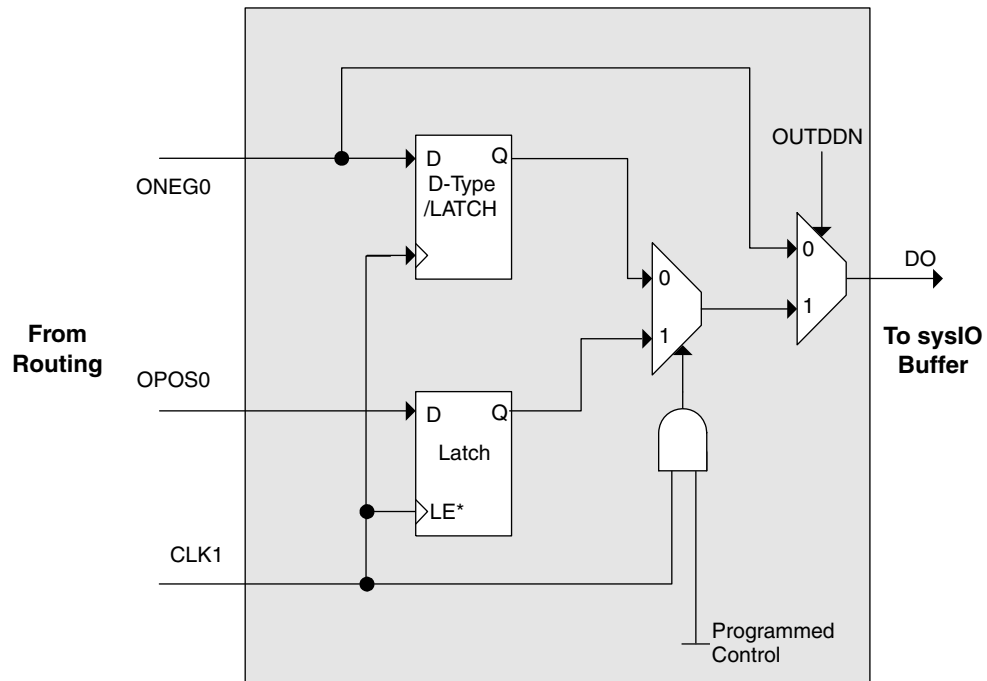

\*Latch is transparent when input is low.

Figure 2-30. ODDRXB Primitive

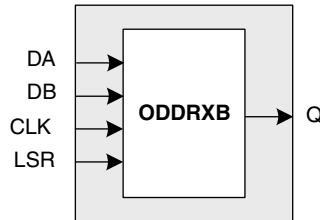

**Tristate Register Block**

The tristate register block provides the ability to register tri-state control signals from the core of the device before they are passed to the sysI/O buffers. The block contains a register for SDR operation and an additional latch for DDR operation. Figure 2-31 shows the diagram of the Tristate Register Block.

In SDR mode, ONEG1 feeds one of the flip-flops that then feeds the output. The flip-flop can be configured a D-type or latch. In DDR mode, ONEG1 is fed into one register on the positive edge of the clock and OPOS1 is latched. A multiplexer running off the same clock selects the correct register for feeding to the output (D0).

Figure 2-31. Tristate Register Block

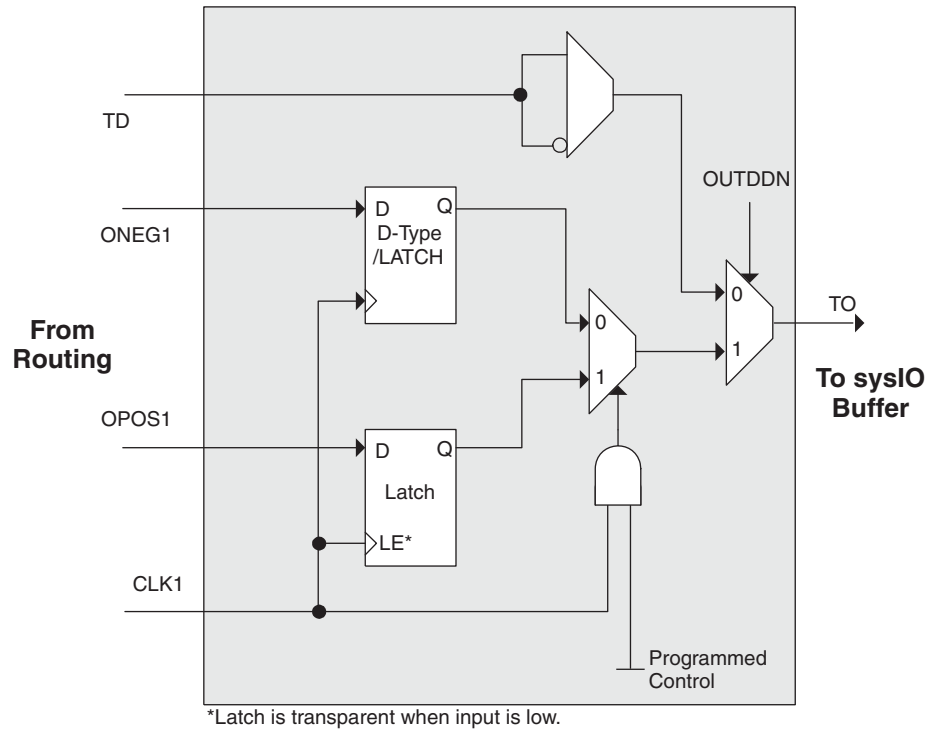

### Control Logic Block

The control logic block allows the selection and modification of control signals for use in the PIO block. A clock is selected from one of the clock signals provided from the general purpose routing and a DQS signal provided from the programmable DQS pin. The clock can optionally be inverted.

The clock enable and local reset signals are selected from the routing and optionally inverted. The global tristate signal is passed through this block.

### DDR Memory Support

Implementing high performance DDR memory interfaces requires dedicated DDR register structures in the input (for read operations) and in the output (for write operations). As indicated in the PIO Logic section, the LatticeEC devices provide this capability. In addition to these registers, the LatticeEC devices contain two elements to simplify the design of input structures for read operations: the DQS delay block and polarity control logic.

### DLL Calibrated DQS Delay Block

Source Synchronous interfaces generally require the input clock to be adjusted in order to correctly capture data at the input register. For most interfaces a PLL is used for this adjustment. However in DDR memories the clock (referred to as DQS) is not free running so this approach cannot be used. The DQS Delay block provides the required clock alignment for DDR memory interfaces.

The DQS signal (selected PIOs only) feeds from the PAD through a DQS delay element to a dedicated DQS routing resource. The DQS signal also feeds polarity control logic, which controls the polarity of the clock to the sync registers in the input register blocks. Figures 2-32 and 2-33 show how the DQS transition signals are routed to the PIOs.

The temperature, voltage and process variations of the DQS delay block are compensated by a set of calibration (6-bit bus) signals from two DLLs on opposite sides of the device. Each DLL compensates DQS Delays in its half of the device as shown in Figure 2-33. The DLL loop is compensated for temperature, voltage and process variations by the system clock and feedback loop.

Figure 2-32. DQS Local Bus.

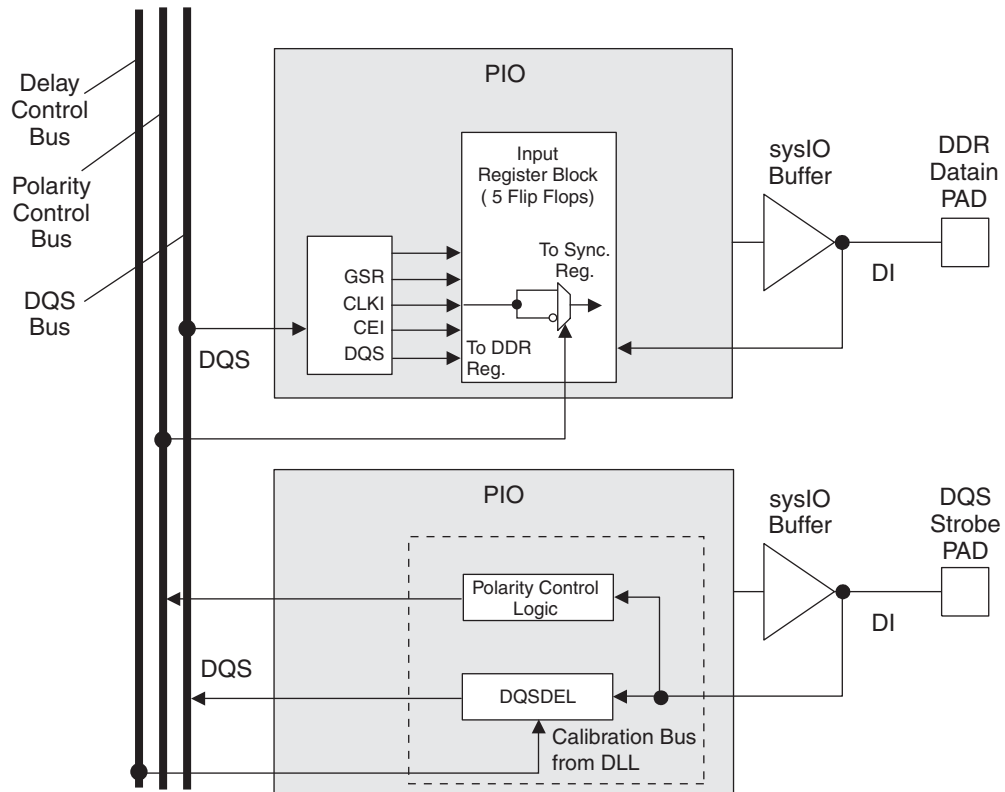
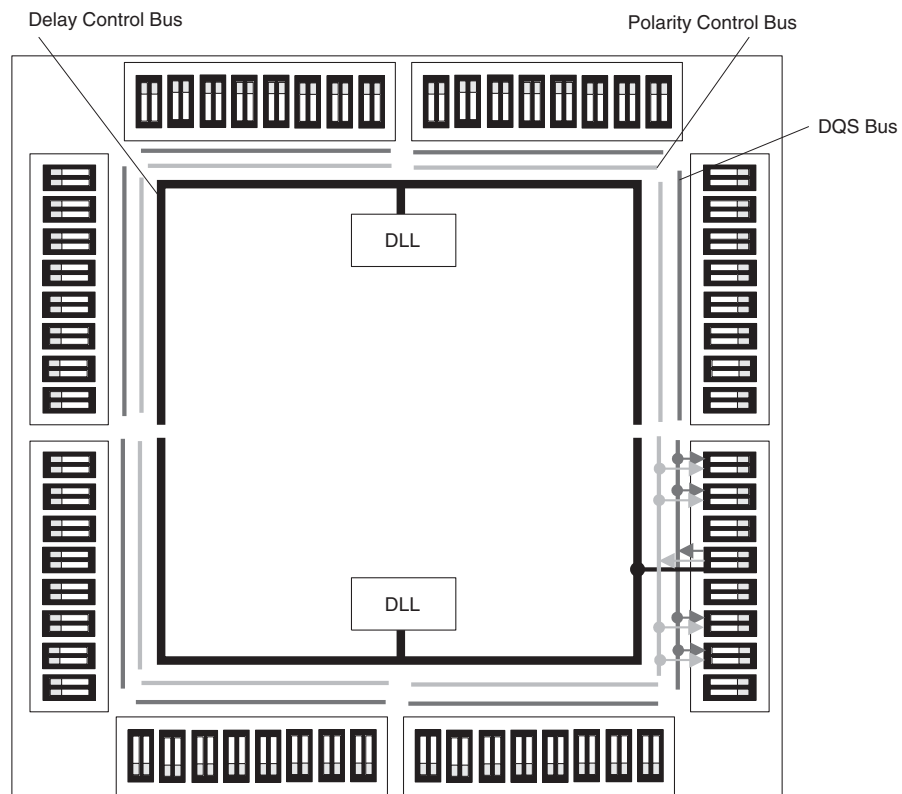

Figure 2-33. DLL Calibration Bus and DQS/DQS Transition Distribution



---

## Polarity Control Logic

In a typical DDR Memory interface design, the phase relation between the incoming delayed DQS strobe and the internal system Clock (during the READ cycle) is unknown.

The LatticeECP/EC family contains dedicated circuits to transfer data between these domains. To prevent setup and hold violations at the domain transfer between DQS (delayed) and the system Clock a clock polarity selector is used. This changes the edge on which the data is registered in the synchronizing registers in the input register block. This requires evaluation at the start of each READ cycle for the correct clock polarity.

Prior to the READ operation in DDR memories DQS is in tristate (pulled by termination). The DDR memory device drives DQS low at the start of the preamble state. A dedicated circuit detects this transition. This signal is used to control the polarity of the clock to the synchronizing registers.

## sysI/O Buffer

Each I/O is associated with a flexible buffer referred to as a sysI/O buffer. These buffers are arranged around the periphery of the device in eight groups referred to as Banks. The sysI/O buffers allow users to implement the wide variety of standards that are found in today's systems including LVCMOS, SSTL, HSTL, LVDS and LVPECL.

## sysI/O Buffer Banks

LatticeECP/EC devices have eight sysI/O buffer banks; each is capable of supporting multiple I/O standards. Each sysI/O bank has its own I/O supply voltage ( $V_{CCIO}$ ), and two voltage references  $V_{REF1}$  and  $V_{REF2}$  resources allowing each bank to be completely independent from each other. Figure 2-34 shows the eight banks and their associated supplies.

In the LatticeECP/EC devices, single-ended output buffers and ratioed input buffers (LVTTL, LVCMOS, PCI and PCI-X) are powered using  $V_{CCIO}$ . LVTTL, LVCMOS33, LVCMOS25 and LVCMOS12 can also be set as fixed threshold input independent of  $V_{CCIO}$ . In addition to the bank  $V_{CCIO}$  supplies, the LatticeECP/EC devices have a  $V_{CC}$  core logic power supply, and a  $V_{CCAUX}$  supply that power all differential and referenced buffers.

Each bank can support up to two separate VREF voltages, VREF1 and VREF2 that set the threshold for the referenced input buffers. In the LatticeECP/EC devices, some dedicated I/O pins in a bank can be configured to be a reference voltage supply pin. Each I/O is individually configurable based on the bank's supply and reference voltages.

Figure 2-34. LatticeECP/EC Banks

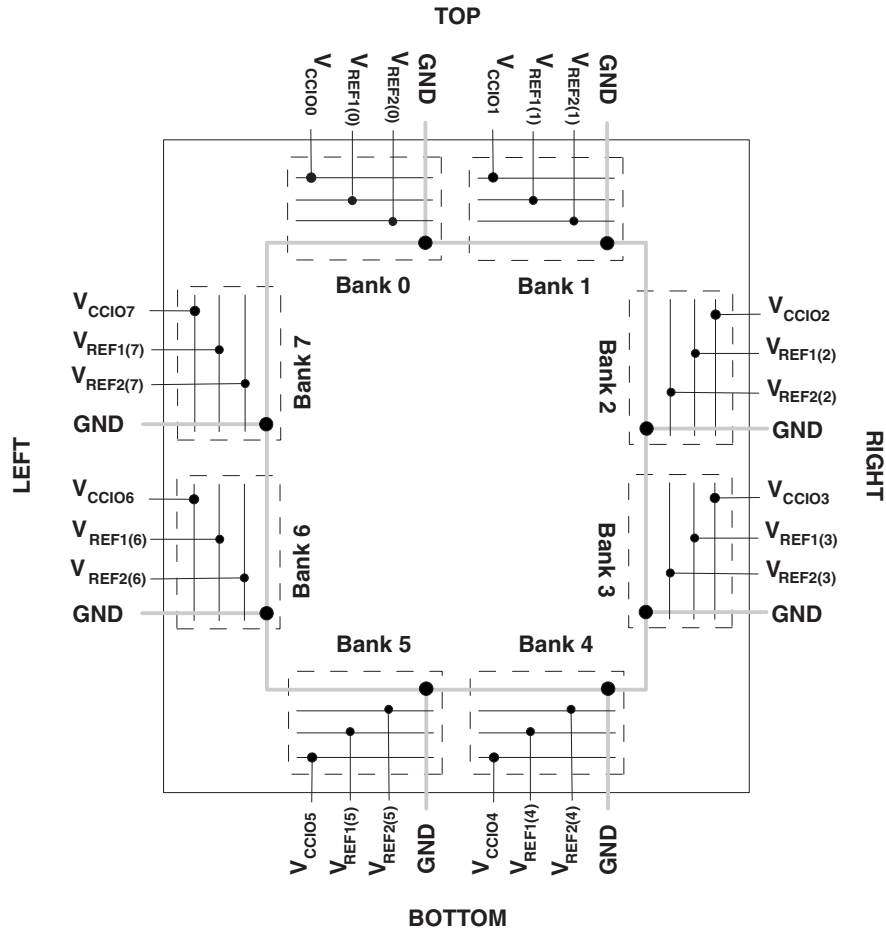

LatticeECP/EC devices contain two types of sysI/O buffer pairs.

1. **Top and Bottom sysI/O Buffer Pairs (Single-Ended Outputs Only)**

The sysI/O buffer pairs in the top and bottom banks of the device consist of two single-ended output drivers and two sets of single-ended input buffers (both ratioed and referenced). The referenced input buffer can also be configured as a differential input.

The two pads in the pair are described as “true” and “comp”, where the true pad is associated with the positive side of the differential input buffer and the comp (complementary) pad is associated with the negative side of the differential input buffer.

Only the I/Os on the top and bottom banks have programmable PCI clamps. These I/O banks also support hot socketing with  $I_{DK}$  less than 1mA. Note that the PCI clamp is enabled after  $V_{CC}$ ,  $V_{CCAUX}$  and  $V_{CCIO}$  are at valid operating levels and the device has been configured.

2. **Left and Right sysI/O Buffer Pairs (Differential and Single-Ended Outputs)**

The sysI/O buffer pairs in the left and right banks of the device consist of two single-ended output drivers, two sets of single-ended input buffers (both ratioed and referenced) and one differential output driver. The referenced input buffer can also be configured as a differential input. In these banks the two pads in the pair are described as “true” and “comp”, where the true pad is associated with the positive side of the differential I/O, and the comp (complementary) pad is associated with the negative side of the differential I/O.

Only the left and right banks have LVDS differential output drivers. See the  $I_{DK}$  specification for I/O leakage current during power-up.



## Typical I/O Behavior During Power-up

The internal power-on-reset (POR) signal is deactivated when  $V_{CC}$  and  $V_{CCAUX}$  have reached satisfactory levels. After the POR signal is deactivated, the FPGA core logic becomes active. It is the user's responsibility to ensure that all other  $V_{CCIO}$  banks are active with valid input logic levels to properly control the output logic states of all the I/O banks that are critical to the application. For more information about controlling the output logic state with valid input logic levels during power-up in LatticeECP/EC devices, see the list of technical documentation at the end of this data sheet.

The  $V_{CC}$  and  $V_{CCAUX}$  supply the power to the FPGA core fabric, whereas the  $V_{CCIO}$  supplies power to the I/O buffers. In order to simplify system design while providing consistent and predictable I/O behavior, it is recommended that the I/O buffers be powered-up prior to the FPGA core fabric.  $V_{CCIO}$  supplies should be powered-up before or together with the  $V_{CC}$  and  $V_{CCAUX}$  supplies.

## Supported Standards

The LatticeECP/EC sysI/O buffer supports both single-ended and differential standards. Single-ended standards can be further subdivided into LVCMOS, LVTTTL and other standards. The buffers support the LVTTTL, LVCMOS 1.2, 1.5, 1.8, 2.5 and 3.3V standards. In the LVCMOS and LVTTTL modes, the buffer has individually configurable options for drive strength, bus maintenance (weak pull-up, weak pull-down, or a bus-keeper latch) and open drain. Other single-ended standards supported include SSTL and HSTL. Differential standards supported include LVDS, BLVDS, LVPECL, RSDS, differential SSTL and differential HSTL. Tables 2-13 and 2-14 show the I/O standards (together with their supply and reference voltages) supported by the LatticeECP/EC devices. For further information about utilizing the sysI/O buffer to support a variety of standards please see the the list of technical information at the end of this data sheet.

**Table 2-13. Supported Input Standards**

Input Standard	$V_{REF}$ (Nom.)	$V_{CCIO}^1$ (Nom.)
<b>Single Ended Interfaces</b>		
LVTTTL	—	—
LVCMOS33 <sup>2</sup>	—	—
LVCMOS25 <sup>2</sup>	—	—
LVCMOS18	—	1.8
LVCMOS15	—	1.5
LVCMOS12 <sup>2</sup>	—	—
PCI	—	3.3
HSTL18 Class I, II	0.9	—
HSTL18 Class III	1.08	—
HSTL15 Class I	0.75	—
HSTL15 Class III	0.9	—
SSTL3 Class I, II	1.5	—
SSTL2 Class I, II	1.25	—
SSTL18 Class I	0.9	—
<b>Differential Interfaces</b>		
Differential SSTL18 Class I	—	—
Differential SSTL2 Class I, II	—	—
Differential SSTL3 Class I, II	—	—
Differential HSTL15 Class I, III	—	—
Differential HSTL18 Class I, II, III	—	—
LVDS, LVPECL, BLVDS, RSDS	—	—

1. When not specified  $V_{CCIO}$  can be set anywhere in the valid operating range.

2. JTAG inputs do not have a fixed threshold option and always follow  $V_{CCJ}$ .

**Table 2-14. Supported Output Standards**

Output Standard	Drive	V <sub>CCIO</sub> (Nom.)
<b>Single-ended Interfaces</b>		
LVTTTL	4mA, 8mA, 12mA, 16mA, 20mA	3.3
LVC MOS33	4mA, 8mA, 12mA 16mA, 20mA	3.3
LVC MOS25	4mA, 8mA, 12mA, 16mA, 20mA	2.5
LVC MOS18	4mA, 8mA, 12mA, 16mA	1.8
LVC MOS15	4mA, 8mA	1.5
LVC MOS12	2mA, 6mA	1.2
LVC MOS33, Open Drain	4mA, 8mA, 12mA 16mA, 20mA	—
LVC MOS25, Open Drain	4mA, 8mA, 12mA 16mA, 20mA	—
LVC MOS18, Open Drain	4mA, 8mA, 12mA 16mA	—
LVC MOS15, Open Drain	4mA, 8mA	—
LVC MOS12, Open Drain	2mA, 6mA	—
PCI33	N/A	3.3
HSTL18 Class I, II, III	N/A	1.8
HSTL15 Class I, III	N/A	1.5
SSTL3 Class I, II	N/A	3.3
SSTL2 Class I, II	N/A	2.5
SSTL18 Class I	N/A	1.8
<b>Differential Interfaces</b>		
Differential SSTL3, Class I, II	N/A	3.3
Differential SSTL2, Class I, II	N/A	2.5
Differential SSTL18, Class I	N/A	1.8
Differential HSTL18, Class I, II, III	N/A	1.8
Differential HSTL15, Class I, III	N/A	1.5
LVDS	N/A	2.5
BLVDS <sup>1</sup>	N/A	2.5
LVPECL <sup>1</sup>	N/A	3.3
RSDS <sup>1</sup>	N/A	2.5

1. Emulated with external resistors.

## Hot Socketing

The LatticeECP/EC devices have been carefully designed to ensure predictable behavior during power-up and power-down. Power supplies can be sequenced in any order. During power up and power-down sequences, the I/Os remain in tristate until the power supply voltage is high enough to ensure reliable operation. In addition, leakage into I/O pins is controlled within specified limits, this allows for easy integration with the rest of the system. These capabilities make the LatticeECP/EC ideal for many multiple power supply and hot-swap applications.

## Configuration and Testing

The following section describes the configuration and testing features of the LatticeECP/EC devices.

### IEEE 1149.1-Compliant Boundary Scan Testability

All LatticeECP/EC devices have boundary scan cells that are accessed through an IEEE 1149.1 compliant test access port (TAP). This allows functional testing of the circuit board, on which the device is mounted, through a serial scan path that can access all critical logic nodes. Internal registers are linked internally, allowing test data to

be shifted in and loaded directly onto test nodes, or test data to be captured and shifted out for verification. The test access port consists of dedicated I/Os: TDI, TDO, TCK and TMS. The test access port has its own supply voltage  $V_{CCJ}$  and can operate with LVCMOS3.3, 2.5, 1.8, 1.5 and 1.2 standards.

For more details on boundary scan test, please see information regarding additional technical documentation at the end of this data sheet.

## Device Configuration

All LatticeECP/EC devices contain two possible ports that can be used for device configuration. The test access port (TAP), which supports bit-wide configuration, and the sysCONFIG port that supports both byte-wide and serial configuration.

The TAP supports both the IEEE Std. 1149.1 Boundary Scan specification and the IEEE Std. 1532 In-System Configuration specification. The sysCONFIG port is a 20-pin interface with six of the I/Os used as dedicated pins and the rest being dual-use pins (please refer to TN1053 for more information about using the dual-use pins as general purpose I/O). There are four configuration options for LatticeECP/EC devices:

1. Industry standard SPI memories.
2. Industry standard byte wide flash and ispMACH 4000 for control/addressing.
3. Configuration from system microprocessor via the configuration bus or TAP.
4. Industry standard FPGA board memory.

On power-up, the FPGA SRAM is ready to be configured with the sysCONFIG port active. The IEEE 1149.1 serial mode can be activated any time after power-up by sending the appropriate command through the TAP port. Once a configuration port is selected, that port is locked and another configuration port cannot be activated until the next power-up sequence.

For more information about device configuration, please see the list of technical documentation at the end of this data sheet.

## Internal Logic Analyzer Capability (ispTRACY)

All LatticeECP/EC devices support an internal logic analyzer diagnostic feature. The diagnostic features provide capabilities similar to an external logic analyzer, such as programmable event and trigger condition and deep trace memory. This feature is enabled by Lattice's ispTRACY. The ispTRACY utility is added into the user design at compile time.

For more information about ispTRACY, please see information regarding additional technical documentation at the end of this data sheet.

## External Resistor

LatticeECP/EC devices require a single external, 10K ohm +/- 1% value between the XRES pin and ground. Device configuration will not be completed if this resistor is missing. There is no boundary scan register on the external resistor pad.

## Oscillator

Every LatticeECP/EC device has an internal CMOS oscillator which is used to derive a master clock for configuration. The oscillator and the master clock run continuously. The default value of the master clock is 2.5MHz. Table 2-15 lists all the available Master Clock frequencies. When a different Master Clock is selected during the design process, the following sequence takes place:

1. User selects a different Master Clock frequency.
2. During configuration the device starts with the default (2.5MHz) Master Clock frequency.
3. The clock configuration settings are contained in the early configuration bit stream.
4. The Master Clock frequency changes to the selected frequency once the clock configuration bits are received.

For further information about the use of this oscillator for configuration, please see the list of technical documentation at the end of this data sheet.

**Table 2-15. Selectable Master Clock (CCLK) Frequencies During Configuration**

CCLK (MHz)	CCLK (MHz)	CCLK (MHz)
2.5*	13	45
4.3	15	51
5.4	20	55
6.9	26	60
8.1	30	130
9.2	34	—
10.0	41	—

## Density Shifting

The LatticeECP/EC family has been designed to ensure that different density devices in the same package have the same pin-out. Furthermore, the architecture ensures a high success rate when performing design migration from lower density parts to higher density parts. In many cases, it is also possible to shift a lower utilization design targeted for a high-density device to a lower density device. However, the exact details of the final resource utilization will impact the likely success in each case.

### Absolute Maximum Ratings<sup>1, 2, 3</sup>

Supply Voltage $V_{CC}$ . . . . .	-0.5 to 1.32V
Supply Voltage $V_{CCAUX}$ . . . . .	-0.5 to 3.75V
Supply Voltage $V_{CCJ}$ . . . . .	-0.5 to 3.75V
Output Supply Voltage $V_{CCIO}$ . . . . .	-0.5 to 3.75V
Dedicated Input Voltage Applied <sup>4</sup> . . . . .	-0.5 to 4.25V
I/O Tristate Voltage Applied <sup>4</sup> . . . . .	-0.5 to 3.75V
Storage Temperature (Ambient) . . . . .	-65 to 150°C
Junction Temp. (Tj). . . . .	+125°C

1. Stress above those listed under the “Absolute Maximum Ratings” may cause permanent damage to the device. Functional operation of the device at these or any other conditions above those indicated in the operational sections of this specification is not implied.
2. Compliance with the Lattice *Thermal Management* document is required.
3. All voltages referenced to GND.
4. Overshoot and undershoot of -2V to ( $V_{IHMAX} + 2$ ) volts is permitted for a duration of <20ns.

### Recommended Operating Conditions

Symbol	Parameter	Min.	Max.	Units
$V_{CC}$	Core Supply Voltage	1.14	1.26	V
$V_{CCAUX}^3$	Auxiliary Supply Voltage	3.135	3.465	V
$V_{CCPLL}$	PLL Supply Voltage for ECP/EC33	1.14	1.26	V
$V_{CCIO}^{1, 2}$	I/O Driver Supply Voltage	1.140	3.465	V
$V_{CCJ}^1$	Supply Voltage for IEEE 1149.1 Test Access Port	1.140	3.465	V
$t_{JCOM}$	Junction Commercial Operation	0	85	°C
$t_{JIND}$	Junction Industrial Operation	-40	100	°C

1. If  $V_{CCIO}$  or  $V_{CCJ}$  is set to 1.2V, they must be connected to the same power supply as  $V_{CC}$ . If  $V_{CCIO}$  or  $V_{CCJ}$  is set to 3.3V, they must be connected to the same power supply as  $V_{CCAUX}$ .
2. See recommended voltages by I/O standard in subsequent table.
3.  $V_{CCAUX}$  ramp rate must not exceed 3mV/ $\mu$ s for commercial and 0.6 mV/ $\mu$ s for industrial device operations during power up when transitioning between 0.8V and 1.8V.

### Hot Socketing Specifications<sup>1, 2, 3, 4</sup>

Symbol	Parameter	Condition	Min.	Typ.	Max.	Units
<b>Top and Bottom General Purpose sysI/Os (Banks 0, 1, 4 and 5), JTAG and Dedicated sysCONFIG Pins</b>						
$I_{DK\_TB}$	Input or I/O Leakage Current	$0 \leq V_{IN} \leq V_{IH} (MAX.)$	—	—	+/-1000	$\mu$ A
<b>Left and Right General Purpose sysI/Os (Banks 2, 3, 6 and 7)</b>						
$I_{DK\_LR}$	Input or I/O Leakage Current	$V_{IN} \leq V_{CCIO}$	—	—	+/-1000	$\mu$ A
		$V_{IN} > V_{CCIO}$	—	35	—	mA

1. Insensitive to sequence of  $V_{CC}$ ,  $V_{CCAUX}$  and  $V_{CCIO}$ . However, assumes monotonic rise/fall rates for  $V_{CC}$ ,  $V_{CCAUX}$  and  $V_{CCIO}$ .
2.  $0 \leq V_{CC} \leq V_{CC} (MAX)$ ,  $0 \leq V_{CCIO} \leq V_{CCIO} (MAX)$  or  $0 \leq V_{CCAUX} \leq V_{CCAUX} (MAX)$ .
3.  $I_{DK}$  is additive to  $I_{PU}$ ,  $I_{PW}$  or  $I_{BH}$ .
4. LVCMOS and LVTTTL only.

## DC Electrical Characteristics

## Over Recommended Operating Conditions

Symbol	Parameter	Condition	Min.	Typ.	Max.	Units
$I_{IL}, I_{IH}^1$	Input or I/O Leakage	$0 \leq V_{IN} \leq (V_{CCIO} - 0.2V)$	—	—	10	$\mu A$
$I_{IH}^{1,3}$	Input or I/O High Leakage	$(V_{CCIO} - 0.2V) \leq V_{IH} \leq 3.6V$	—	—	40	$\mu A$
$I_{PU}$	I/O Active Pull-up Current	$0 \leq V_{IN} \leq 0.7 V_{CCIO}$	-30	—	-150	$\mu A$
$I_{PD}$	I/O Active Pull-down Current	$V_{IL} (MAX) \leq V_{IN} \leq V_{IH} (MAX)$	30	—	150	$\mu A$
$I_{BHLS}$	Bus Hold Low sustaining current	$V_{IN} = V_{IL} (MAX)$	30	—	—	$\mu A$
$I_{BHHS}$	Bus Hold High sustaining current	$V_{IN} = 0.7V_{CCIO}$	-30	—	—	$\mu A$
$I_{BHLO}$	Bus Hold Low Overdrive current	$0 \leq V_{IN} \leq V_{IH} (MAX)$	—	—	150	$\mu A$
$I_{BHLH}$	Bus Hold High Overdrive current	$0 \leq V_{IN} \leq V_{IH} (MAX)$	—	—	-150	$\mu A$
$V_{BHT}$	Bus Hold trip Points	$0 \leq V_{IN} \leq V_{IH} (MAX)$	$V_{IL} (MAX)$	—	$V_{IH} (MIN)$	V
C1	I/O Capacitance <sup>2</sup>	$V_{CCIO} = 3.3V, 2.5V, 1.8V, 1.5V, 1.2V,$ $V_{CC} = 1.2V, V_{IO} = 0 \text{ to } V_{IH} (MAX)$	—	8	—	pf
C2	Dedicated Input Capacitance <sup>2</sup>	$V_{CCIO} = 3.3V, 2.5V, 1.8V, 1.5V, 1.2V,$ $V_{CC} = 1.2V, V_{IO} = 0 \text{ to } V_{IH} (MAX)$	—	6	—	pf

1. Input or I/O leakage current is measured with the pin configured as an input or as an I/O with the output driver tri-stated. It is not measured with the output driver active. Bus maintenance circuits are disabled.
2.  $T_A$  25°C,  $f = 1.0MHz$
3. For top and bottom general purpose I/O pins, when  $V_{IH}$  is higher than  $V_{CCIO}$ , a transient current typically of 30ns in duration or less with a peak current of 6mA can occur on the high-to-low transition. For left and right I/O banks,  $V_{IH}$  must be less than or equal to  $V_{CCIO}$ .

**Supply Current (Standby)<sup>1, 2, 3, 4</sup>****Over Recommended Operating Conditions**

Symbol	Parameter	Device	Typ. <sup>5</sup>	Units
I <sub>CC</sub>	Core Power Supply Current	LFEC1	6	mA
		LFEC3	10	mA
		LFEC6/LFEC6	15	mA
		LFEC10/LFEC10	25	mA
		LFEC15/LFEC15	35	mA
		LFEC20/LFEC20	60	mA
		LFEC33/LFEC33	85	mA
I <sub>CCAUX</sub>	Auxiliary Power Supply Current		15	mA
I <sub>CCPLL</sub>	PLL Power Supply Current		5	mA
I <sub>CCIO</sub>	Bank Power Supply Current <sup>6</sup>		2	mA
I <sub>CCJ</sub>	V <sub>CCJ</sub> Power Supply Current		5	mA

1. For further information about supply current, please see the list of technical documentation at the end of this data sheet.
2. Assumes all outputs are tristated, all inputs are configured as LVCMOS and held at the V<sub>CCIO</sub> or GND.
3. Frequency 0MHz.
4. Pattern represents a "blank" configuration data file.
5. T<sub>J</sub>=25°C, power supplies at nominal voltage.
6. Per bank.

**Initialization Supply Current<sup>1, 2, 3, 4, 5, 6</sup>**

**Over Recommended Operating Conditions**

Symbol	Parameter	Devices	Typ. <sup>6</sup>	Units
I <sub>CC</sub>	Core Power Supply Current	LFEC1	25	mA
		LFEC3	40	mA
		LFEC6/LFEC6	50	mA
		LFEC10/LFEC10	60	mA
		LFEC15/LFEC15	70	mA
		LFEC20/LFEC20	150	mA
		LFEC33/LFEC33	220	mA
I <sub>CCAUX</sub>	Auxiliary Power Supply Current	LFEC1	30	mA
		LFEC3	30	mA
		LFEC6/LFEC6	30	mA
		LFEC10/LFEC10	35	mA
		LFEC15/LFEC15	35	mA
		LFEC20/LFEC20	40	mA
		LFEC33/LFEC33	40	mA
I <sub>CCPLL</sub>	PLL Power Supply Current		12	mA
I <sub>CCIO</sub>	Bank Power Supply Current <sup>7</sup>	LFEC1	4	mA
		LFEC3	5	mA
		LFEC6/LFEC6	6	mA
		LFEC10/LFEC10	6	mA
		LFEC15/LFEC15	7	mA
		LFEC20/LFEC20	8	mA
		LFEC33/LFEC33	8	mA
I <sub>CCJ</sub>	V <sub>CCJ</sub> Power Supply Current		20	mA

1. Until DONE signal is active.
2. For further information about supply current, please see the list of technical documentation at the end of this data sheet.
3. Assumes all outputs are tristated, all inputs are configured as LVCMOS and held at the V<sub>CCIO</sub> or GND.
4. Frequency 0MHz.
5. Pattern represents typical design with 65% logic, 55% EBR, 10% routing utilization.
6. T<sub>J</sub>=25°C, power supplies at nominal voltage.
7. Per bank.



**sysI/O Recommended Operating Conditions**

Standard	V <sub>CCIO</sub>			V <sub>REF</sub> (V)		
	Min.	Typ.	Max.	Min.	Typ.	Max.
LVC MOS 3.3	3.135	3.3	3.465	—	—	—
LVC MOS 2.5	2.375	2.5	2.625	—	—	—
LVC MOS 1.8	1.71	1.8	1.89	—	—	—
LVC MOS 1.5	1.425	1.5	1.575	—	—	—
LVC MOS 1.2	1.14	1.2	1.26	—	—	—
LV TTL	3.135	3.3	3.465	—	—	—
PCI	3.135	3.3	3.465	—	—	—
SSTL18 Class I	1.71	1.8	1.89	0.833	0.90	0.969
SSTL2 Class I, II	2.375	2.5	2.625	1.15	1.25	1.35
SSTL3 Class I, II	3.135	3.3	3.465	1.3	1.5	1.7
HSTL15 Class I	1.425	1.5	1.575	0.68	0.75	0.9
HSTL15 Class III	1.425	1.5	1.575	—	0.9	—
HSTL 18 Class I, II	1.71	1.8	1.89	—	0.9	—
HSTL 18 Class III	1.71	1.8	1.89	—	1.08	—
LVDS	2.375	2.5	2.625	—	—	—
LVPECL <sup>1</sup>	3.135	3.3	3.465	—	—	—
BLVDS <sup>1</sup>	2.375	2.5	2.625	—	—	—
RSDS <sup>1</sup>	2.375	2.5	2.625	—	—	—

1. Outputs are implemented with the addition of external resistors. V<sub>CCIO</sub> applies to outputs only.

## sysI/O Single-Ended DC Electrical Characteristics

Input/Output Standard	$V_{IL}$		$V_{IH}$		$V_{OL}$ Max. (V)	$V_{OH}$ Min. (V)	$I_{OL}^1$ (mA)	$I_{OH}^1$ (mA)
	Min. (V)	Max. (V)	Min. (V)	Max. (V)				
LVCMOS 3.3	-0.3	0.8	2.0	3.6	0.4	$V_{CCIO} - 0.4$	20, 16, 12, 8, 4	-20, -16, -12, -8, -4
					0.2	$V_{CCIO} - 0.2$	0.1	-0.1
LVTTTL	-0.3	0.8	2.0	3.6	0.4	$V_{CCIO} - 0.4$	20, 16, 12, 8, 4	-20, -16, -12, -8, -4
					0.2	$V_{CCIO} - 0.2$	0.1	-0.1
LVCMOS 2.5	-0.3	0.7	1.7	3.6	0.4	$V_{CCIO} - 0.4$	20, 16, 12, 8, 4	-20, -16, -12, -8, -4
					0.2	$V_{CCIO} - 0.2$	0.1	-0.1
LVCMOS 1.8	-0.3	$0.35V_{CCIO}$	$0.65V_{CCIO}$	3.6	0.4	$V_{CCIO} - 0.4$	16, 12, 8, 4	-16, -12, -8, -4
					0.2	$V_{CCIO} - 0.2$	0.1	-0.1
LVCMOS 1.5	-0.3	$0.35V_{CCIO}$	$0.65V_{CCIO}$	3.6	0.4	$V_{CCIO} - 0.4$	8, 4	-8, -4
					0.2	$V_{CCIO} - 0.2$	0.1	-0.1
LVCMOS 1.2	-0.3	$0.35V_{CC}$	$0.65V_{CC}$	3.6	0.4	$V_{CCIO} - 0.4$	6, 2	-6, -2
					0.2	$V_{CCIO} - 0.2$	0.1	-0.1
PCI	-0.3	$0.3V_{CCIO}$	$0.5V_{CCIO}$	3.6	$0.1V_{CCIO}$	$0.9V_{CCIO}$	1.5	-0.5
SSTL3 class I	-0.3	$V_{REF} - 0.2$	$V_{REF} + 0.2$	3.6	0.7	$V_{CCIO} - 1.1$	8	-8
SSTL3 class II	-0.3	$V_{REF} - 0.2$	$V_{REF} + 0.2$	3.6	0.5	$V_{CCIO} - 0.9$	16	-16
SSTL2 class I	-0.3	$V_{REF} - 0.18$	$V_{REF} + 0.18$	3.6	0.54	$V_{CCIO} - 0.62$	7.6	-7.6
SSTL2 class II	-0.3	$V_{REF} - 0.18$	$V_{REF} + 0.18$	3.6	0.35	$V_{CCIO} - 0.43$	15.2	-15.2
SSTL18 class I	-0.3	$V_{REF} - 0.125$	$V_{REF} + 0.125$	3.6	0.4	$V_{CCIO} - 0.4$	6.7	-6.7
HSTL15 class I	-0.3	$V_{REF} - 0.1$	$V_{REF} + 0.1$	3.6	0.4	$V_{CCIO} - 0.4$	8	-8
HSTL15 class III	-0.3	$V_{REF} - 0.1$	$V_{REF} + 0.1$	3.6	0.4	$V_{CCIO} - 0.4$	24	-8
HSTL18 class I	-0.3	$V_{REF} - 0.1$	$V_{REF} + 0.1$	3.6	0.4	$V_{CCIO} - 0.4$	9.6	-9.6
HSTL18 class II	-0.3	$V_{REF} - 0.1$	$V_{REF} + 0.1$	3.6	0.4	$V_{CCIO} - 0.4$	16	-16
HSTL18 class III	-0.3	$V_{REF} - 0.1$	$V_{REF} + 0.1$	3.6	0.4	$V_{CCIO} - 0.4$	24	-8

1. The average DC current drawn by I/Os between GND connections, or between the last GND in an I/O bank and the end of an I/O bank, as shown in the logic signal connections table shall not exceed  $n * 8\text{mA}$ . Where n is the number of I/Os between bank GND connections or between the last GND in a bank and the end of a bank.

**sys/O Differential Electrical Characteristics****LVDS****Over Recommended Operating Conditions**

Parameter Symbol	Parameter Description	Test Conditions	Min.	Typ.	Max.	Units
$V_{INP}, V_{INM}$	Input voltage		0	—	2.4	V
$V_{THD}$	Differential input threshold		+/-100	—	—	mV
$V_{CM}$	Input common mode voltage	$100\text{mV} \leq V_{THD}$	$V_{THD}/2$	1.2	1.8	V
		$200\text{mV} \leq V_{THD}$	$V_{THD}/2$	1.2	1.9	V
		$350\text{mV} \leq V_{THD}$	$V_{THD}/2$	1.2	2.0	V
$I_{IN}$	Input current	Power on or power off	—	—	+/-10	$\mu\text{A}$
$V_{OH}$	Output high voltage for $V_{OP}$ or $V_{OM}$	$R_T = 100 \text{ Ohm}$	—	1.38	1.60	V
$V_{OL}$	Output low voltage for $V_{OP}$ or $V_{OM}$	$R_T = 100 \text{ Ohm}$	0.9V	1.03	—	V
$V_{OD}$	Output voltage differential	$(V_{OP} - V_{OM}), R_T = 100 \text{ Ohm}$	250	350	450	mV
$\Delta V_{OD}$	Change in $V_{OD}$ between high and low		—	—	50	mV
$V_{OS}$	Output voltage offset	$(V_{OP} + V_{OM})/2, R_T = 100 \text{ Ohm}$	1.125	1.25	1.375	V
$\Delta V_{OS}$	Change in $V_{OS}$ between H and L		—	—	50	mV
$I_{OSD}$	Output short circuit current	$V_{OD} = 0\text{V}$ Driver outputs shorted	—	—	6	mA

**Differential HSTL and SSTL**

Differential HSTL and SSTL outputs are implemented as a pair of complementary single-ended outputs. All allowable single-ended output classes (class I and class II) are supported in this mode.

**LVDS25E**

The top and bottom side of LatticeECP/EC devices support LVDS outputs via emulated complementary LVCMOS outputs in conjunction with a parallel resistor across the driver outputs. The scheme shown in

Figure 3-1 is one possible solution for point-to-point signals.

**Figure 3-1. LVDS25E Output Termination Example**

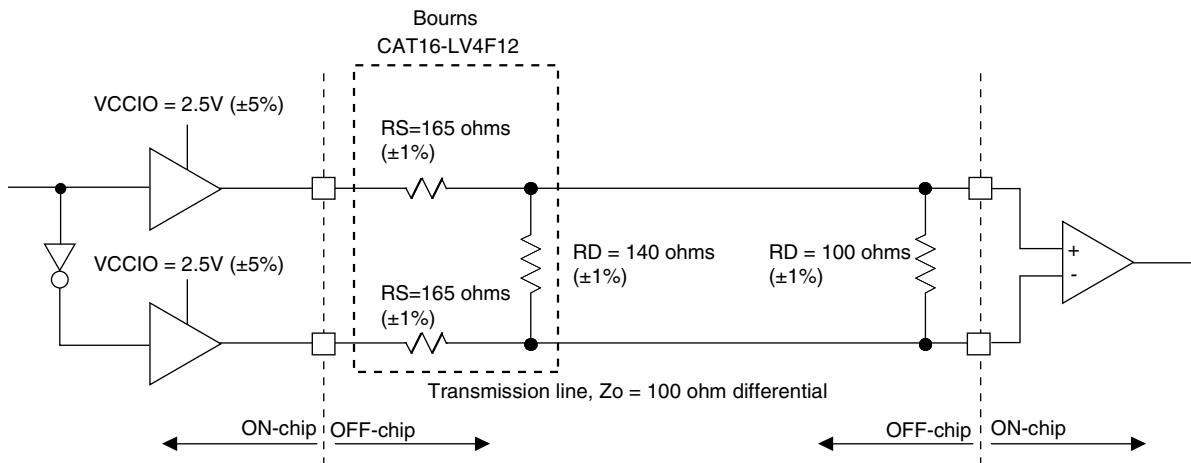

**Table 3-1. LVDS25E DC Conditions**

Parameter	Description	Typical	Units
V <sub>OH</sub>	Output high voltage	1.42	V
V <sub>OL</sub>	Output low voltage	1.08	V
V <sub>OD</sub>	Output differential voltage	0.35	V
V <sub>CM</sub>	Output common mode voltage	1.25	V
Z <sub>BACK</sub>	Back impedance	100	Ω

**BLVDS**

The LatticeECP/EC devices support BLVDS standard. This standard is emulated using complementary LVCMOS outputs in conjunction with a parallel external resistor across the driver outputs. BLVDS is intended for use when multi-drop and bi-directional multi-point differential signaling is required. The scheme shown in Figure 3-2 is one possible solution for bi-directional multi-point differential signals.

**Figure 3-2. BLVDS Multi-point Output Example**

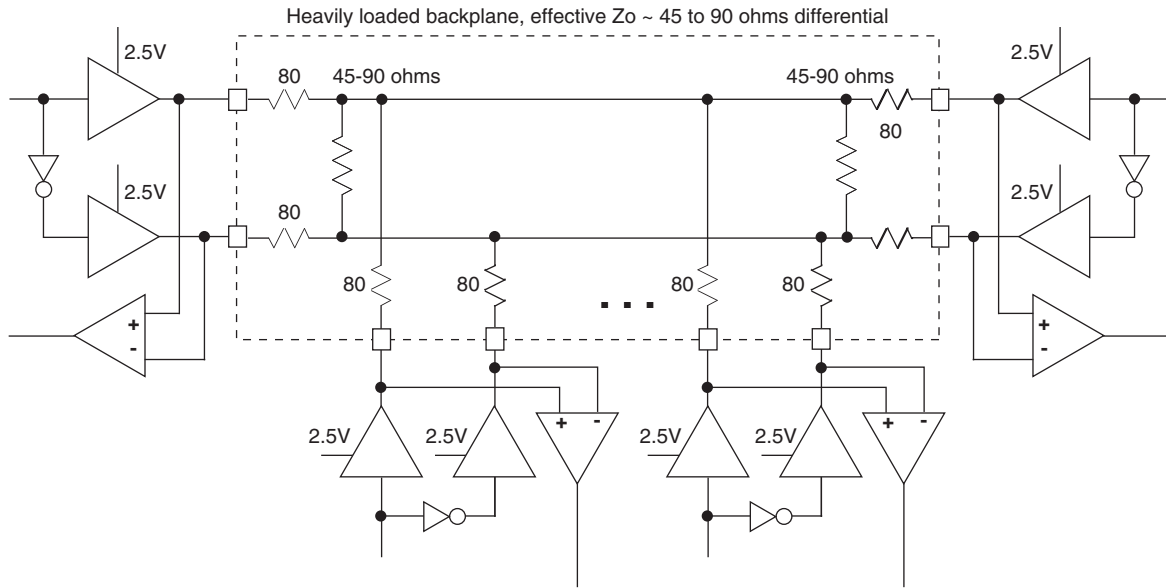

**Table 3-2. BLVDS DC Conditions<sup>1</sup>**

**Over Recommended Operating Conditions**

Parameter	Description	Typical		Units
		Zo = 45	Zo = 90	
Z <sub>OUT</sub>	Output impedance	100	100	ohm
R <sub>TLEFT</sub>	Left end termination	45	90	ohm
R <sub>TRIGHT</sub>	Right end termination	45	90	ohm
V <sub>OH</sub>	Output high voltage	1.375	1.48	V
V <sub>OL</sub>	Output low voltage	1.125	1.02	V
V <sub>OD</sub>	Output differential voltage	0.25	0.46	V
V <sub>CM</sub>	Output common mode voltage	1.25	1.25	V
I <sub>DC</sub>	DC output current	11.2	10.2	mA

1. For input buffer, see LVDS table.

**LVPECL**

The LatticeECP/EC devices support differential LVPECL standard. This standard is emulated using complementary LVCMOS outputs in conjunction with a parallel resistor across the driver outputs. The LVPECL input standard is supported by the LVDS differential input buffer. The scheme shown in Figure 3-3 is one possible solution for point-to-point signals.

**Figure 3-3. Differential LVPECL**

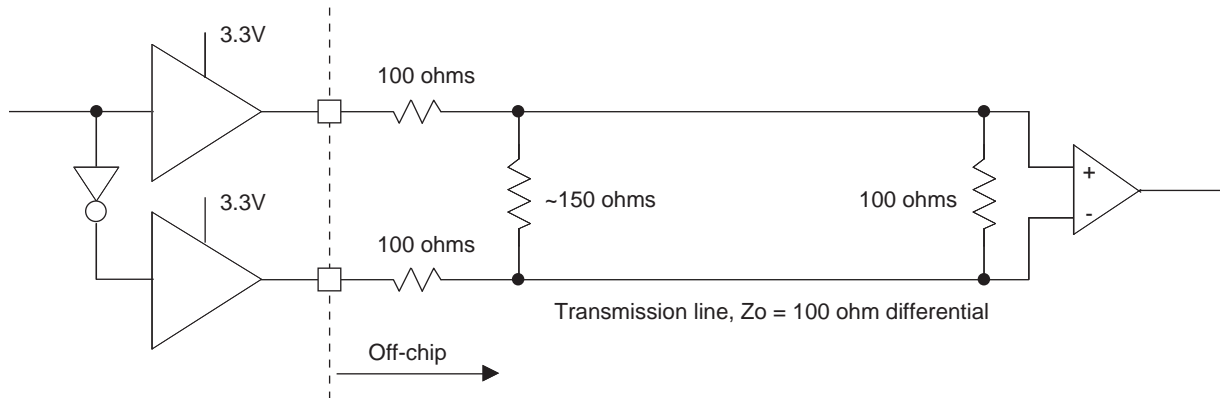

**Table 3-3. LVPECL DC Conditions<sup>1</sup>**

**Over Recommended Operating Conditions**

Parameter	Description	Typical	Units
Z <sub>OUT</sub>	Output impedance	100	ohm
R <sub>P</sub>	Driver parallel resistor	150	ohm
R <sub>T</sub>	Receiver termination	100	ohm
V <sub>OH</sub>	Output high voltage	2.03	V
V <sub>OL</sub>	Output low voltage	1.27	V
V <sub>OD</sub>	Output differential voltage	0.76	V
V <sub>CM</sub>	Output common mode voltage	1.65	V
Z <sub>BACK</sub>	Back impedance	85.7	ohm
I <sub>DC</sub>	DC output current	12.7	mA

1. For input buffer, see LVDS table.

For further information about LVPECL, BLVDS and other differential interfaces please see the list of technical information at the end of this data sheet.

**RSDS**

The LatticeECP/EC devices support differential RSDS standard. This standard is emulated using complementary LVCMOS outputs in conjunction with a parallel resistor across the driver outputs. The RSDS input standard is supported by the LVDS differential input buffer. The scheme shown in Figure 3-4 is one possible solution for RSDS standard implementation. Use LVDS25E mode with suggested resistors for RSDS operation. Resistor values in Figure 3-4 are industry standard values for 1% resistors.

**Figure 3-4. RSDS (Reduced Swing Differential Standard)**

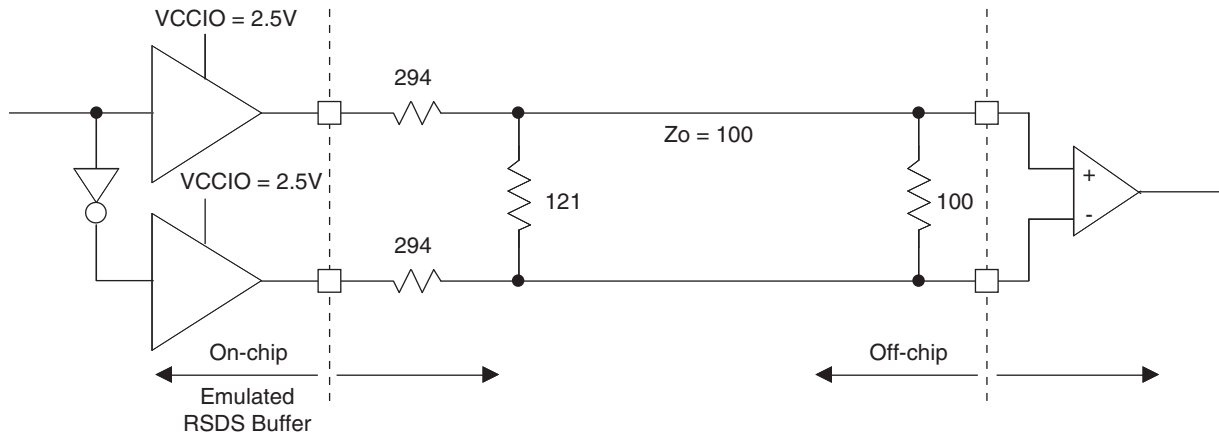

**Table 3-4. RSDS DC Conditions**

Parameter	Description	Typical	Units
Z <sub>OUT</sub>	Output impedance	20	ohm
R <sub>S</sub>	Driver series resistor	294	ohm
R <sub>P</sub>	Driver parallel resistor	121	ohm
R <sub>T</sub>	Receiver termination	100	ohm
V <sub>OH</sub>	Output high voltage	1.35	V
V <sub>OL</sub>	Output low voltage	1.15	V
V <sub>OD</sub>	Output differential voltage	0.20	V
V <sub>CM</sub>	Output common mode voltage	1.25	V
Z <sub>BACK</sub>	Back impedance	101.5	ohm
I <sub>DC</sub>	DC output current	3.66	mA

**Typical Building Block Function Performance****Pin-to-Pin Performance (LVCMOS25 12mA Drive)**

Function	-5 Timing	Units
<b>Basic Functions</b>		
16-bit decoder	5.5	ns
32-bit decoder	6.9	ns
64-bit decoder	7.1	ns
4:1 MUX	4.3	ns
8:1 MUX	4.7	ns
16:1 MUX	5.0	ns
32:1 MUX	5.5	ns

**Register-to-Register Performance<sup>1</sup>**

Function	-5 Timing	Units
<b>Basic Functions</b>		
16 bit decoder	410	MHz
32 bit decoder	283	MHz
64 bit decoder	272	MHz
4:1 MUX	613	MHz
8:1 MUX	565	MHz
16:1 MUX	526	MHz
32:1 MUX	442	MHz
8-bit adder	363	MHz
16-bit adder	353	MHz
64-bit adder	196	MHz
16-bit counter	414	MHz
32-bit counter	317	MHz
64-bit counter	216	MHz
64-bit accumulator	178	MHz
<b>Embedded Memory Functions</b>		
256x36 Single Port RAM	280	MHz
512x18 True-Dual Port RAM	280	MHz
<b>Distributed Memory Functions</b>		
16x2 Single Port RAM	460	MHz
64x2 Single Port RAM	375	MHz
128x4 Single Port RAM	294	MHz
32x2 Pseudo-Dual Port RAM	392	MHz
64x4 Pseudo-Dual Port RAM	332	MHz
<b>DSP Function<sup>2</sup></b>		
9x9 Pipelined Multiply/Accumulate	242	MHz
18x18 Pipelined Multiply/Accumulate	238	MHz
36x36 Pipelined Multiply	235	MHz

1. These timing numbers were generated using the ispLEVER design tool. Exact performance may vary with design and tool version. The tool uses internal parameters that have been characterized but are not tested on every device.

2. Applies to LatticeECP devices only.

Timing v.G 0.30



## Derating Timing Tables

Logic Timing provided in the following sections of the data sheet and the ispLEVER design tools are worst-case numbers in the operating range. Actual delays at nominal temperature and voltage for best-case process, can be much better than the values given in the tables. To calculate logic timing numbers at a particular temperature and voltage multiply the noted numbers with the derating factors provided below.

The junction temperature for the FPGA depends on the power dissipation by the device, the package thermal characteristics ( $\Theta_{JA}$ ), and the ambient temperature, as calculated with the following equation:

$$T_{JMAX} = T_{AMAX} + (\text{Power} * \Theta_{JA})$$

The user must determine this temperature and then use it to determine the derating factor based on the following derating tables:  $T_J$  °C.

**Table 3-5. Delay Derating Table for Internal Blocks**

$T_J$ °C Commercial	$T_J$ °C Industrial	Power Supply Voltage		
		1.14V	1.2V	1.26V
—	-40	0.82	0.77	0.71
—	-25	0.82	0.76	0.71
0	20	0.89	0.83	0.78
25	45	0.93	0.87	0.81
85	105	1.00	0.94	0.89

## LatticeECP/EC External Switching Characteristics

Over Recommended Operating Conditions

Parameter	Description	Device	-5		-4		-3		Units
			Min.	Max.	Min.	Max.	Min.	Max.	
<b>General I/O Pin Parameters (Using Primary Clock without PLL)<sup>1</sup></b>									
$t_{CO}^7$	Clock to Output - PIO Output Register	LFEC1	—	5.09	—	6.11	—	7.13	ns
		LFEC3	—	5.71	—	6.85	—	7.99	ns
		LFEC6	—	5.60	—	6.72	—	7.84	ns
		LFEC10	—	5.47	—	6.57	—	7.66	ns
		LFEC15	—	5.67	—	6.81	—	7.94	ns
		LFEC20	—	5.89	—	7.07	—	8.25	ns
		LFEC33	—	6.19	—	7.42	—	8.66	ns
$t_{SU}^7$	Clock to Data Setup - PIO Input Register	LFEC1	-0.08	—	-0.10	—	-0.12	—	ns
		LFEC3	-0.70	—	-0.84	—	-0.98	—	ns
		LFEC6	-0.63	—	-0.76	—	-0.89	—	ns
		LFEC10	-0.43	—	-0.52	—	-0.61	—	ns
		LFEC15	-0.70	—	-0.84	—	-0.98	—	ns
		LFEC20	-0.88	—	-1.06	—	-1.24	—	ns
		LFEC33	-1.12	—	-1.34	—	-1.56	—	ns
$t_H^7$	Clock to Data Hold - PIO Input Register	LFEC1	2.19	—	2.62	—	3.06	—	ns
		LFEC3	2.80	—	3.36	—	3.92	—	ns
		LFEC6	2.69	—	3.23	—	3.77	—	ns
		LFEC10	2.56	—	3.08	—	3.59	—	ns
		LFEC15	2.76	—	3.32	—	3.87	—	ns
		LFEC20	2.99	—	3.58	—	4.18	—	ns
		LFEC33	3.28	—	3.93	—	4.59	—	ns
$t_{SU\_DEL}^7$	Clock to Data Setup - PIO Input Register with Data Input Delay	LFEC1	3.36	—	4.03	—	4.70	—	ns
		LFEC3	2.74	—	3.29	—	3.84	—	ns
		LFEC6	2.81	—	3.37	—	3.93	—	ns
		LFEC10	3.01	—	3.61	—	4.21	—	ns
		LFEC15	2.74	—	3.29	—	3.83	—	ns
		LFEC20	2.56	—	3.07	—	3.58	—	ns
		LFEC33	2.32	—	2.79	—	3.25	—	ns
$t_{H\_DEL}^7$	Clock to Data Hold - PIO Input Register with Input Data Delay	LFEC1	-1.31	—	-1.57	—	-1.83	—	ns
		LFEC3	-0.70	—	-0.83	—	-0.97	—	ns
		LFEC6	-0.80	—	-0.96	—	-1.12	—	ns
		LFEC10	-0.93	—	-1.12	—	-1.30	—	ns
		LFEC15	-0.73	—	-0.88	—	-1.02	—	ns
		LFEC20	-0.51	—	-0.61	—	-0.71	—	ns
		LFEC33	-0.22	—	-0.26	—	-0.30	—	ns
$f_{MAX\_IO}^2$	Clock Frequency of I/O and PFU Register	All	—	420	—	378	—	340	Mhz
<b>DDR I/O Pin Parameters<sup>3,4,5</sup></b>									
$t_{DVADQ}$	Data Valid After DQS (DDR Read)	All	—	0.19	—	0.19	—	0.19	UI
$t_{DVEDQ}$	Data Hold After DQS (DDR Read)	All	0.67	—	0.67	—	0.67	—	UI

## LatticeECP/EC External Switching Characteristics (Continued)

Over Recommended Operating Conditions

Parameter	Description	Device	-5		-4		-3		Units
			Min.	Max.	Min.	Max.	Min.	Max.	
$t_{DQVBS}$	Data Valid Before DQS	All	0.20	—	0.20	—	0.20	—	UI
$t_{DQVAS}$	Data Valid After DQS	All	0.20	—	0.20	—	0.20	—	UI
$f_{MAX\_DDR}$	DDR Clock Frequency	All	95	200	95	166	95	133	MHz
<b>Primary and Secondary Clock<sup>6</sup></b>									
$f_{MAX\_PRI}^2$	Frequency for Primary Clock Tree	All	—	420	—	378	—	340	MHz
$t_{W\_PRI}$	Clock Pulse Width for Primary Clock	All	1.19	—	1.19	—	1.19	—	ns
$t_{SKEW\_PRI}$	Primary Clock Skew within an I/O Bank	All	—	250	—	300	—	350	ps

1. General timing numbers based on LVCMOS2.5V, 12 mA. Loading of 0 pF.
  2. Using LVDS I/O standard.
  3. DDR timing numbers based on SSTL I/O.
  4. DDR specifications are characterized but not tested.
  5. UI is average bit period.
  6. Based on a single primary clock.
  7. These timing numbers were generated using ispLEVER design tool. Exact performance may vary with design and tool version. The tool uses internal parameters that have been characterized but are not tested on every device.
- Timing v.G 0.30

Figure 3-5. DDR Timings

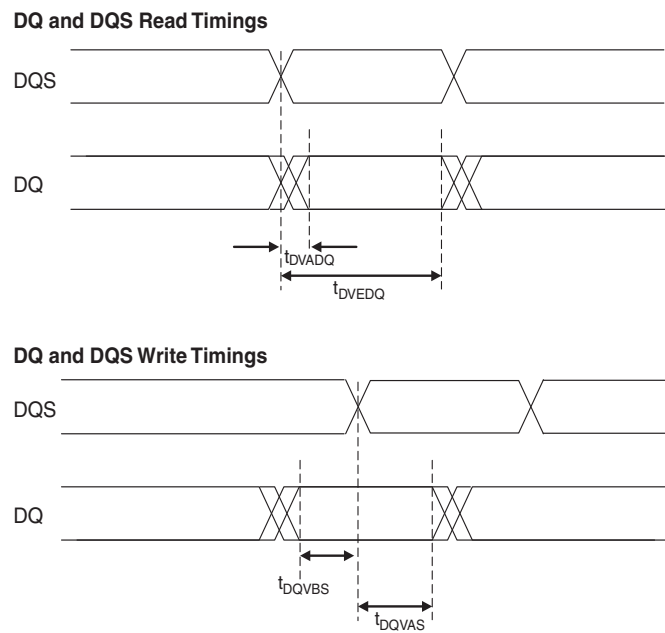

## LatticeECP/EC Internal Switching Characteristics

Over Recommended Operating Conditions

Parameter	Description	-5		-4		-3		Units
		Min.	Max.	Min.	Max.	Min.	Max.	
<b>PFU/PFF Logic Mode Timing</b>								
t <sub>LUT4_PFU</sub>	LUT4 Delay (A to D Inputs to F Output)	—	0.25	—	0.31	—	0.36	ns
t <sub>LUT6_PFU</sub>	LUT6 Delay (A to D Inputs to OFX Output)	—	0.40	—	0.48	—	0.56	ns
t <sub>LSR_PFU</sub>	Set/Reset to Output of PFU	—	0.81	—	0.98	—	1.14	ns
t <sub>SUM_PFU</sub>	Clock to Mux (M0,M1) Input Setup Time	0.12	—	0.14	—	0.16	—	ns
t <sub>HM_PFU</sub>	Clock to Mux (M0,M1) Input Hold Time	-0.05	—	-0.06	—	-0.06	—	ns
t <sub>SUD_PFU</sub>	Clock to D Input Setup Time	0.12	—	0.14	—	0.16	—	ns
t <sub>HD_PFU</sub>	Clock to D Input Hold time	-0.03	—	-0.03	—	-0.04	—	ns
t <sub>CK2Q_PFU</sub>	Clock to Q Delay, D-type Register Configuration	—	0.36	—	0.44	—	0.51	ns
t <sub>LE2Q_PFU</sub>	Clock to Q Delay Latch Configuration	—	0.48	—	0.58	—	0.68	ns
t <sub>LD2Q_PFU</sub>	D to Q Throughput Delay when Latch is Enabled	—	0.50	—	0.60	—	0.69	ns
<b>PFU Dual Port Memory Mode Timing</b>								
t <sub>CORAM_PFU</sub>	Clock to Output	—	0.36	—	0.44	—	0.51	ns
t <sub>SUDATA_PFU</sub>	Data Setup Time	-0.20	—	-0.24	—	-0.28	—	ns
t <sub>HDATA_PFU</sub>	Data Hold Time	0.26	—	0.31	—	0.36	—	ns
t <sub>SUADDR_PFU</sub>	Address Setup Time	-0.51	—	-0.62	—	-0.72	—	ns
t <sub>HADDR_PFU</sub>	Address Hold Time	0.64	—	0.77	—	0.90	—	ns
t <sub>SUWREN_PFU</sub>	Write/Read Enable Setup Time	-0.24	—	-0.29	—	-0.34	—	ns
t <sub>HWREN_PFU</sub>	Write/Read Enable Hold Time	0.30	—	0.36	—	0.42	—	ns
<b>PIC Timing</b>								
<b>PIO Input/Output Buffer Timing</b>								
t <sub>IN_PIO</sub>	Input Buffer Delay	—	0.56	—	0.67	—	0.78	ns
t <sub>OUT_PIO</sub>	Output Buffer Delay	—	1.92	—	2.31	—	2.69	ns
<b>IOLOGIC Input/Output Timing</b>								
t <sub>SUI_PIO</sub>	Input Register Setup Time (Data Before Clock)	0.90	—	1.08	—	1.26	—	ns
t <sub>HI_PIO</sub>	Input Register Hold Time (Data after Clock)	0.62	—	0.74	—	0.87	—	ns
t <sub>COO_PIO</sub>	Output Register Clock to Output Delay	—	0.33	—	0.40	—	0.46	ns
t <sub>SUCE_PIO</sub>	Input Register Clock Enable Setup Time	-0.10	—	-0.12	—	-0.14	—	ns
t <sub>HCE_PIO</sub>	Input Register Clock Enable Hold Time	0.12	—	0.14	—	0.17	—	ns
t <sub>SULSR_PIO</sub>	Set/Reset Setup Time	0.18	—	0.21	—	0.25	—	ns
t <sub>HLSR_PIO</sub>	Set/Reset Hold Time	-0.15	—	-0.18	—	-0.21	—	ns
<b>EBR Timing</b>								
t <sub>CO_EBR</sub>	Clock to Output from Address or Data	—	3.64	—	4.37	—	5.10	ns
t <sub>COO_EBR</sub>	Clock to Output from EBR output Register	—	0.74	—	0.88	—	1.03	ns
t <sub>SUDATA_EBR</sub>	Setup Data to EBR Memory	-0.29	—	-0.35	—	-0.41	—	ns
t <sub>HDATA_EBR</sub>	Hold Data to EBR Memory	0.37	—	0.44	—	0.52	—	ns
t <sub>SUADDR_EBR</sub>	Setup Address to EBR Memory	-0.29	—	-0.35	—	-0.41	—	ns
t <sub>HADDR_EBR</sub>	Hold Address to EBR Memory	0.37	—	0.45	—	0.52	—	ns
t <sub>SUWREN_EBR</sub>	Setup Write/Read Enable to EBR Memory	-0.18	—	-0.22	—	-0.26	—	ns
t <sub>HWREN_EBR</sub>	Hold Write/Read Enable to EBR Memory	0.23	—	0.28	—	0.33	—	ns

**LatticeECP/EC Internal Switching Characteristics (Continued)**

Over Recommended Operating Conditions

Parameter	Description	-5		-4		-3		Units
		Min.	Max.	Min.	Max.	Min.	Max.	
t <sub>SUCE_EBR</sub>	Clock Enable Setup Time to EBR Output Register	0.18	—	0.21	—	0.25	—	ns
t <sub>HCE_EBR</sub>	Clock Enable Hold Time to EBR Output Register	-0.14	—	-0.17	—	-0.20	—	ns
t <sub>RSTO_EBR</sub>	Reset To Output Delay Time from EBR Output Register	—	1.47	—	1.76	—	2.05	ns
<b>PLL Parameters</b>								
t <sub>RSTREC</sub>	Reset Recovery to Rising Clock	1.00	—	1.00	—	1.00	—	ns
t <sub>RSTSU</sub>	Reset Signal Setup Time	1.00	—	1.00	—	1.00	—	ns
<b>DSP Block Timing<sup>2,3</sup></b>								
t <sub>SUI_DSP</sub>	Input Register Setup Time	-0.38	—	-0.30	—	-0.23	—	ns
t <sub>HI_DSP</sub>	Input Register Hold Time	0.71	—	0.86	—	1.00	—	ns
t <sub>SUP_DSP</sub>	Pipeline Register Setup Time	3.31	—	3.98	—	4.64	—	ns
t <sub>HP_DSP</sub>	Pipeline Register Hold Time	0.71	—	0.86	—	1.00	—	ns
t <sub>SUO_DSP<sup>4</sup></sub>	Output Register Setup Time	5.54	—	6.64	—	7.75	—	ns
t <sub>HO_DSP<sup>4</sup></sub>	Output Register Hold Time	0.71	—	0.86	—	1.00	—	ns
t <sub>COI_DSP<sup>4</sup></sub>	Input Register Clock to Output Time	—	7.50	—	9.00	—	10.50	ns
t <sub>COP_DSP<sup>4</sup></sub>	Pipeline Register Clock to Output Time	—	4.66	—	5.60	—	6.53	ns
t <sub>COO_DSP</sub>	Output Register Clock to Output Time	—	1.47	—	1.77	—	2.06	ns
t <sub>SUADSUB</sub>	AdSub Input Register Setup Time	-0.38	—	-0.30	—	-0.23	—	ns
t <sub>HADSUB</sub>	AdSub Input Register Hold Time	0.71	—	0.86	—	1.00	—	ns

1. Internal parameters are characterized but not tested on every device.

2. These parameters apply to LatticeECP devices only.

3. DSP Block is configured in Multiply Add/Sub 18 x 18 Mode.

4. These parameters include the Adder Subtractor block in the path.

Timing v.G 0.30

## Timing Diagrams

### PFU Timing Diagrams

Figure 3-6. Slice Single/Dual Port Write Cycle Timing

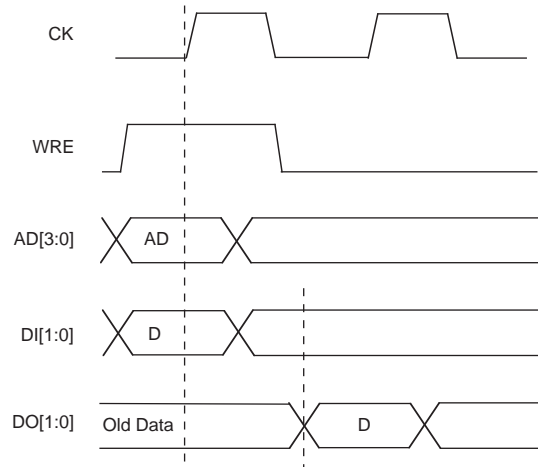
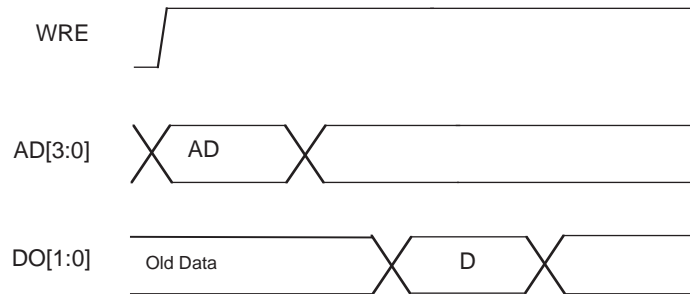
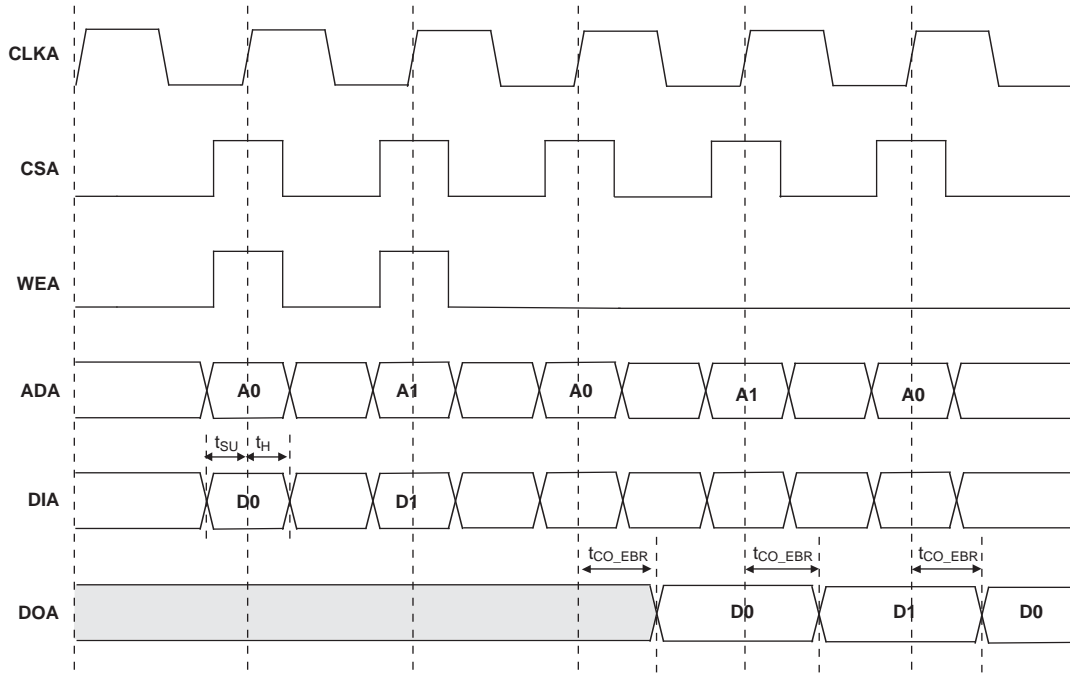

Figure 3-7. Slice Single /Dual Port Read Cycle Timing



**EBR Memory Timing Diagrams**

**Figure 3-8. Read/Write Mode (Normal)**



Note: Input data and address are registered at the positive edge of the clock and output data appears after the positive edge of the clock.

**Figure 3-9. Read/Write Mode with Input and Output Registers**

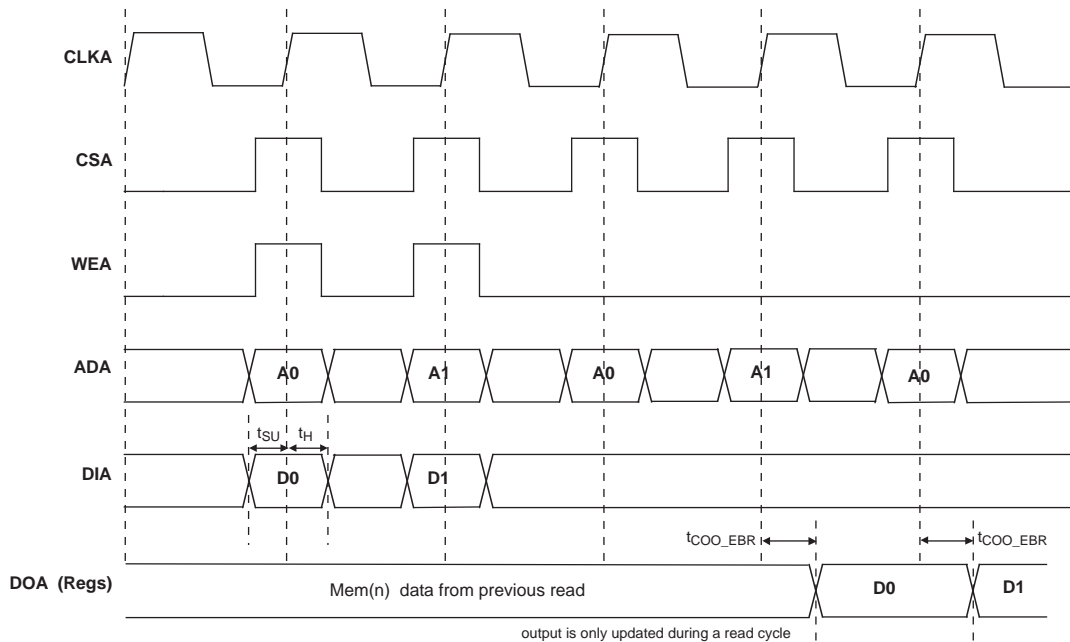
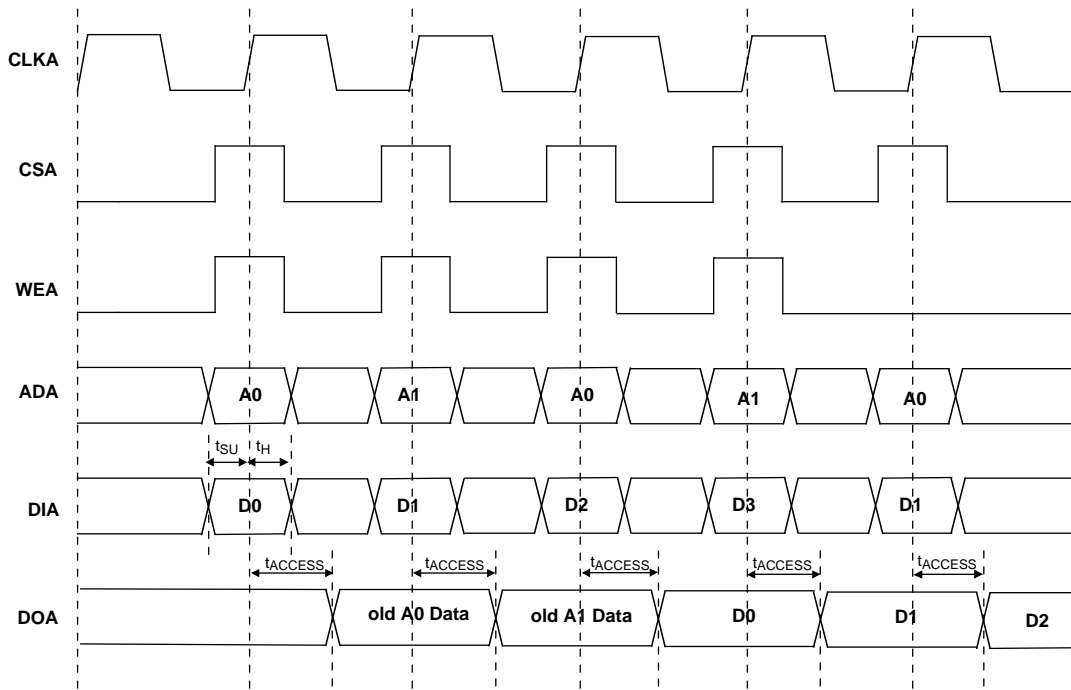
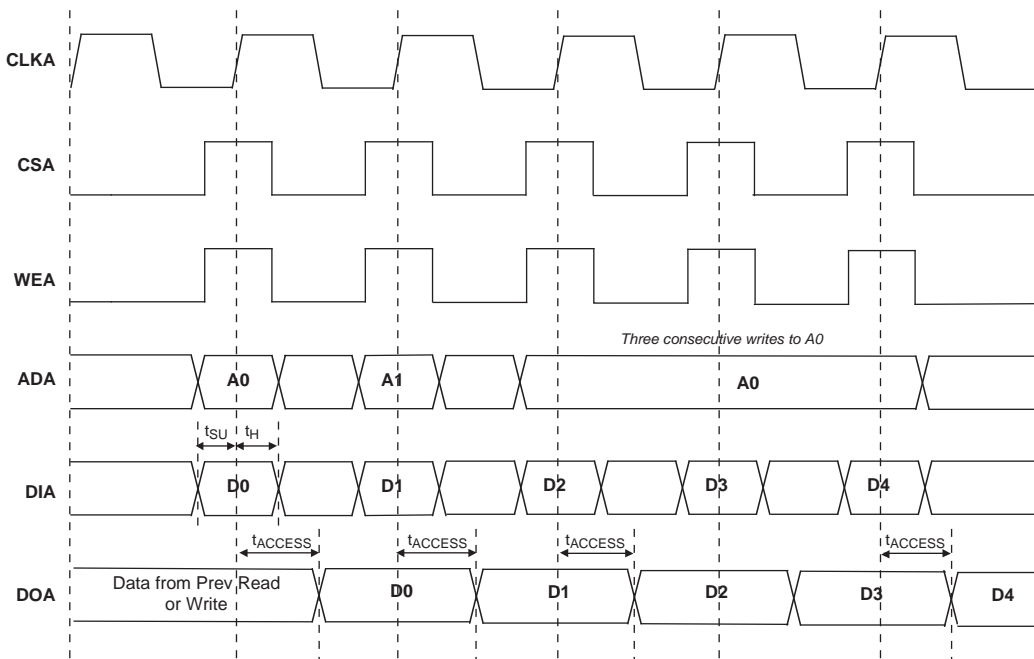

Figure 3-10. Read Before Write (SP Read/Write on Port A, Input Registers Only)



Note: Input data and address are registered at the positive edge of the clock and output data appears after the positive edge of the clock.

Figure 3-11. Write Through (SP Read/Write On Port A, Input Registers Only)



Note: Input data and address are registered at the positive edge of the clock and output data appears after the positive edge of the clock.



**LatticeECP/EC Family Timing Adders<sup>1, 2, 3</sup>****Over Recommended Operating Conditions**

Buffer Type	Description	-5	-4	-3	Units
<b>Input Adjusters</b>					
LVDS25	LVDS	0.41	0.50	0.58	ns
BLVDS25	BLVDS	0.41	0.50	0.58	ns
LVPECL33	LVPECL	0.50	0.60	0.70	ns
HSTL18_I	HSTL_18 class I	0.41	0.49	0.57	ns
HSTL18_II	HSTL_18 class II	0.41	0.49	0.57	ns
HSTL18_III	HSTL_18 class III	0.41	0.49	0.57	ns
HSTL18D_I	Differential HSTL 18 class I	0.37	0.44	0.52	ns
HSTL18D_II	Differential HSTL 18 class II	0.37	0.44	0.52	ns
HSTL18D_III	Differential HSTL 18 class III	0.37	0.44	0.52	ns
HSTL15_I	HSTL_15 class I	0.40	0.48	0.56	ns
HSTL15_III	HSTL_15 class III	0.40	0.48	0.56	ns
HSTL15D_I	Differential HSTL 15 class I	0.37	0.44	0.51	ns
HSTL15D_III	Differential HSTL 15 class III	0.37	0.44	0.51	ns
SSTL33_I	SSTL_3 class I	0.46	0.55	0.64	ns
SSTL33_II	SSTL_3 class II	0.46	0.55	0.64	ns
SSTL33D_I	Differential SSTL_3 class I	0.39	0.47	0.55	ns
SSTL33D_II	Differential SSTL_3 class II	0.39	0.47	0.55	ns
SSTL25_I	SSTL_2 class I	0.43	0.51	0.60	ns
SSTL25_II	SSTL_2 class II	0.43	0.51	0.60	ns
SSTL25D_I	Differential SSTL_2 class I	0.38	0.45	0.53	ns
SSTL25D_II	Differential SSTL_2 class II	0.38	0.45	0.53	ns
SSTL18_I	SSTL_18 class I	0.40	0.48	0.56	ns
SSTL18D_I	Differential SSTL_18 class I	0.37	0.44	0.51	ns
LVTTTL33	LVTTTL	0.07	0.09	0.10	ns
LVC MOS33	LVC MOS 3.3	0.07	0.09	0.10	ns
LVC MOS25	LVC MOS 2.5	0.00	0.00	0.00	ns
LVC MOS18	LVC MOS 1.8	0.07	0.09	0.10	ns
LVC MOS15	LVC MOS 1.5	0.24	0.29	0.33	ns
LVC MOS12	LVC MOS 1.2	1.27	1.52	1.77	ns
PCI33	PCI	0.07	0.09	0.10	ns
<b>Output Adjusters</b>					
LVDS25E	LVDS 2.5 E	0.12	0.14	0.17	ns
LVDS25	LVDS 2.5	-0.44	-0.53	-0.62	ns
BLVDS25	BLVDS 2.5	0.33	0.40	0.46	ns
LVPECL33	LVPECL 3.3	0.20	0.24	0.28	ns
HSTL18_I	HSTL_18 class I	-0.10	-0.12	-0.14	ns
HSTL18_II	HSTL_18 class II	0.06	0.07	0.08	ns
HSTL18_III	HSTL_18 class III	0.15	0.19	0.22	ns
HSTL18D_I	Differential HSTL 18 class I	-0.10	-0.12	-0.14	ns
HSTL18D_II	Differential HSTL 18 class II	0.06	0.07	0.08	ns
HSTL18D_III	Differential HSTL 18 class III	0.15	0.19	0.22	ns
HSTL15_I	HSTL_15 class I	0.08	0.10	0.11	ns

**LatticeECP/EC Family Timing Adders<sup>1, 2, 3</sup> (Continued)**

Over Recommended Operating Conditions

Buffer Type	Description	-5	-4	-3	Units
HSTL15_II	HSTL_15 class II	0.10	0.12	0.14	ns
HSTL15_III	HSTL_15 class III	0.10	0.12	0.14	ns
HSTL15D_I	Differential HSTL 15 class I	0.08	0.10	0.11	ns
HSTL15D_III	Differential HSTL 15 class III	0.10	0.12	0.14	ns
SSTL33_I	SSTL_3 class I	-0.05	-0.06	-0.07	ns
SSTL33_II	SSTL_3 class II	0.40	0.48	0.56	ns
SSTL33D_I	Differential SSTL_3 class I	-0.05	-0.06	-0.07	ns
SSTL33D_II	Differential SSTL_3 class II	0.40	0.48	0.56	ns
SSTL25_I	SSTL_2 class I	0.05	0.07	0.08	ns
SSTL25_II	SSTL_2 class II	0.25	0.30	0.35	ns
SSTL25D_I	Differential SSTL_2 class I	0.05	0.07	0.08	ns
SSTL25D_II	Differential SSTL_2 class II	0.25	0.30	0.35	ns
SSTL18_I	SSTL_1.8 class I	0.01	0.01	0.01	ns
SSTL18D_I	Differential SSTL_1.8 class I	0.01	0.01	0.01	ns
LVTTTL33_4mA	LVTTTL 4mA drive	0.09	0.11	0.13	ns
LVTTTL33_8mA	LVTTTL 8mA drive	0.07	0.08	0.09	ns
LVTTTL33_12mA	LVTTTL 12mA drive	-0.03	-0.04	-0.05	ns
LVTTTL33_16mA	LVTTTL 16mA drive	0.36	0.43	0.51	ns
LVTTTL33_20mA	LVTTTL 20mA drive	0.28	0.33	0.39	ns
LVC MOS33_4mA	LVC MOS 3.3 4mA drive	0.09	0.11	0.13	ns
LVC MOS33_8mA	LVC MOS 3.3 8mA drive	0.07	0.08	0.09	ns
LVC MOS33_12mA	LVC MOS 3.3 12mA drive	-0.03	-0.04	-0.05	ns
LVC MOS33_16mA	LVC MOS 3.3 16mA drive	0.36	0.43	0.51	ns
LVC MOS33_20mA	LVC MOS 3.3 20mA drive	0.28	0.33	0.39	ns
LVC MOS25_4mA	LVC MOS 2.5 4mA drive	0.18	0.21	0.25	ns
LVC MOS25_8mA	LVC MOS 2.5 8mA drive	0.10	0.12	0.14	ns
LVC MOS25_12mA	LVC MOS 2.5 12mA drive	0.00	0.00	0.00	ns
LVC MOS25_16mA	LVC MOS 2.5 16mA drive	0.22	0.26	0.31	ns
LVC MOS25_20mA	LVC MOS 2.5 20mA drive	0.14	0.16	0.19	ns
LVC MOS18_4mA	LVC MOS 1.8 4mA drive	0.15	0.18	0.21	ns
LVC MOS18_8mA	LVC MOS 1.8 8mA drive	0.06	0.08	0.09	ns
LVC MOS18_12mA	LVC MOS 1.8 12mA drive	0.01	0.01	0.01	ns
LVC MOS18_16mA	LVC MOS 1.8 16mA drive	0.16	0.19	0.22	ns
LVC MOS15_4mA	LVC MOS 1.5 4mA drive	0.26	0.31	0.36	ns
LVC MOS15_8mA	LVC MOS 1.5 8mA drive	0.04	0.04	0.05	ns
LVC MOS12_2mA	LVC MOS 1.2 2mA drive	0.36	0.43	0.50	ns
LVC MOS12_6mA	LVC MOS 1.2 6mA drive	0.08	0.10	0.11	ns
LVC MOS12_4mA	LVC MOS 1.2 4mA drive	0.36	0.43	0.50	ns
PCI33	PCI33	1.05	1.26	1.46	ns

1. Timing adders are characterized but not tested on every device.

2. LVC MOS timing measured with the load specified in Switching Test Conditions table of this document.

3. All other standards according to the appropriate specification.

Timing v.G 0.30

**sysCLOCK PLL Timing****Over Recommended Operating Conditions**

Parameter	Description	Conditions	Min.	Typ.	Max.	Units
$f_{IN}$	Input Clock Frequency (CLKI, CLKFB)		25	—	420	MHz
$f_{OUT}$	Output Clock Frequency (CLKOP, CLKOS)		25	—	420	MHz
$f_{OUT2}$	K-Divider Output Frequency (CLKOK)		0.195	—	210	MHz
$f_{VCO}$	PLL VCO Frequency		420	—	840	MHz
$f_{PFD}$	Phase Detector Input Frequency		25	—	—	MHz
<b>AC Characteristics</b>						
$t_{DT}$	Output Clock Duty Cycle	Default Duty Cycle Elected <sup>3</sup>	45	50	55	%
$t_{PH}^4$	Output Phase Accuracy		—	—	0.05	UI
$t_{OPJIT}^1$	Output Clock Period Jitter	$f_{OUT} \geq 100\text{MHz}$	—	—	+/- 125	ps
		$f_{OUT} < 100\text{MHz}$	—	—	0.02	UIPP
$t_{SK}$	Input Clock to Output Clock Skew	Divider ratio = integer	—	—	+/- 200	ps
$t_W$	Output Clock Pulse Width	At 90% or 10% <sup>3</sup>	1	—	—	ns
$t_{LOCK}^2$	PLL Lock-in Time		—	—	150	$\mu\text{s}$
$t_{PA}$	Programmable Delay Unit		100	250	450	ps
$t_{IPJIT}$	Input Clock Period Jitter		—	—	+/- 200	ps
$t_{FBKDLY}$	External Feedback Delay		—	—	10	ns
$t_{HI}$	Input Clock High Time	90% to 90%	0.5	—	—	ns
$t_{LO}$	Input Clock Low Time	10% to 10%	0.5	—	—	ns
$t_{RST}$	RST Pulse Width		10	—	—	ns

1. Jitter sample is taken over 10,000 samples of the primary PLL output with clean reference clock.

2. Output clock is valid after  $t_{LOCK}$  for PLL reset and dynamic delay adjustment.

3. Using LVDS output buffers.

4. Relative to CLKOP.

Timing v.G 0.30

**LatticeECP/EC sysCONFIG Port Timing Specifications**

Over Recommended Operating Conditions

Parameter	Description	Min.	Typ.	Max.	Units
<b>sysCONFIG Byte Data Flow</b>					
t <sub>SUCBDI</sub>	Byte D[0:7] Setup Time to CCLK	7		—	ns
t <sub>HCBDI</sub>	Byte D[0:7] Hold Time to CCLK	1		—	ns
t <sub>CODO</sub>	Clock to Dout in Flowthrough Mode	—		12	ns
t <sub>SUCS</sub>	CS[0:1] Setup Time to CCLK	7		—	ns
t <sub>HCS</sub>	CS[0:1] Hold Time to CCLK	1		—	ns
t <sub>SUWD</sub>	Write Signal Setup Time to CCLK	7		—	ns
t <sub>HWD</sub>	Write Signal Hold Time to CCLK	1		—	ns
t <sub>DCB</sub>	CCLK to BUSY Delay Time	—		12	ns
t <sub>CORD</sub>	Clock to Out for Read Data	—		12	ns
<b>sysCONFIG Byte Slave Clocking</b>					
t <sub>BSCH</sub>	Byte Slave Clock Minimum High Pulse	6		—	ns
t <sub>BSCL</sub>	Byte Slave Clock Minimum Low Pulse	9		—	ns
t <sub>BSCYC</sub>	Byte Slave Clock Cycle Time	15		—	ns
t <sub>SUSCDI</sub>	Din Setup time to CCLK Slave Mode	7		—	ns
t <sub>HSCDI</sub>	Din Hold Time to CCLK Slave Mode	1		—	ns
t <sub>CODO</sub>	Clock to Dout in Flowthrough Mode	—		12	ns
<b>sysCONFIG Serial (Bit) Data Flow</b>					
t <sub>SUMCDI</sub>	Din Setup time to CCLK Master Mode	7		—	ns
t <sub>HMCDI</sub>	Din Hold Time to CCLK Master Mode	1		—	ns
<b>sysCONFIG Serial Slave Clocking</b>					
t <sub>SSCH</sub>	Serial Slave Clock Minimum High Pulse	6		—	ns
t <sub>SSCL</sub>	Serial Slave Clock Minimum Low Pulse	6		—	ns
<b>sysCONFIG POR, Initialization and Wake Up</b>					
t <sub>ICFG</sub>	Minimum Vcc to INIT High	—		50	ms
t <sub>VMC</sub>	Time from t <sub>ICFG</sub> to Valid Master Clock	—		2	us
t <sub>PRGMRJ</sub>	Program Pin Pulse Rejection	—		8	ns
t <sub>PRGM</sub>	PROGRAMN Low Time to Start Configuration	25		—	ns
t <sub>DINIT</sub>	INIT Low Time	—		1	ms
t <sub>DPPINIT</sub>	Delay Time from PROGRAMN Low to INIT Low	—		37	ns
t <sub>DINITD</sub>	Delay Time from PROGRAMN Low to DONE Low	—		37	ns
t <sub>IODISS</sub>	User I/O Disable from PROGRAMN Low	—		35	ns
t <sub>IOENSS</sub>	User I/O Enabled Time from CCLK Edge During Wake Up Sequence	—		25	ns
t <sub>MWC</sub>	Additional Wake Master Clock Signals after Done Pin High	120		—	cycles
t <sub>SUCFG</sub>	CFG to INITN Setup Time	100		—	ns
t <sub>HCFG</sub>	CFG to INITN Hold Time	100		—	ns
<b>sysCONFIG SPI Port</b>					
t <sub>CFGX</sub>	Init High to CCLK Low	—		80	ns
t <sub>CSSPI</sub>	Init High to CSSPIN Low	—		2	us
t <sub>CSCCLK</sub>	CCLK Low Before CSSPIN Low	0		-	ns
t <sub>SOCDO</sub>	CCLK Low to Output Valid	—		15	ns

**LatticeECP/EC sysCONFIG Port Timing Specifications (Continued)**

Over Recommended Operating Conditions

Parameter	Description	Min.	Typ.	Max.	Units
$t_{SOE}$	CSSPIN Active Setup Time	300		—	ns
$t_{CSPID}$	CSSPIN Low to First Clock Edge Setup Time	300+3cyc		600+6cyc	ns
$f_{MAXSPI}$	Max Frequency for SPI	—		25	MHz
$t_{SUSPI}$	SOSPI Data Setup Time Before CCLK	7		—	ns
$t_{HSPI}$	SOSPI Data Hold Time After CCLK	1		—	ns

Timing v.G 0.30

**Master Clock**

Clock Mode	Min.	Typ.	Max.	Units
2.5MHz	1.75	2.5	3.25	MHz
5 MHz	3.78	5.4	7.02	MHz
10 MHz	7	10	13	MHz
15 MHz	10.5	15	19.5	MHz
20 MHz	14	20	26	MHz
25 MHz	18.2	26	33.8	MHz
30 MHz	21	30	39	MHz
35 MHz	23.8	34	44.2	MHz
40 MHz	28.7	41	53.3	MHz
45 MHz	31.5	45	58.5	MHz
50 MHz	35.7	51	66.3	MHz
55 MHz	38.5	55	71.5	MHz
60 MHz	42	60	78	MHz
Duty Cycle	40	—	60	%

Timing v.G 0.30

Figure 3-12. sysCONFIG Parallel Port Read Cycle

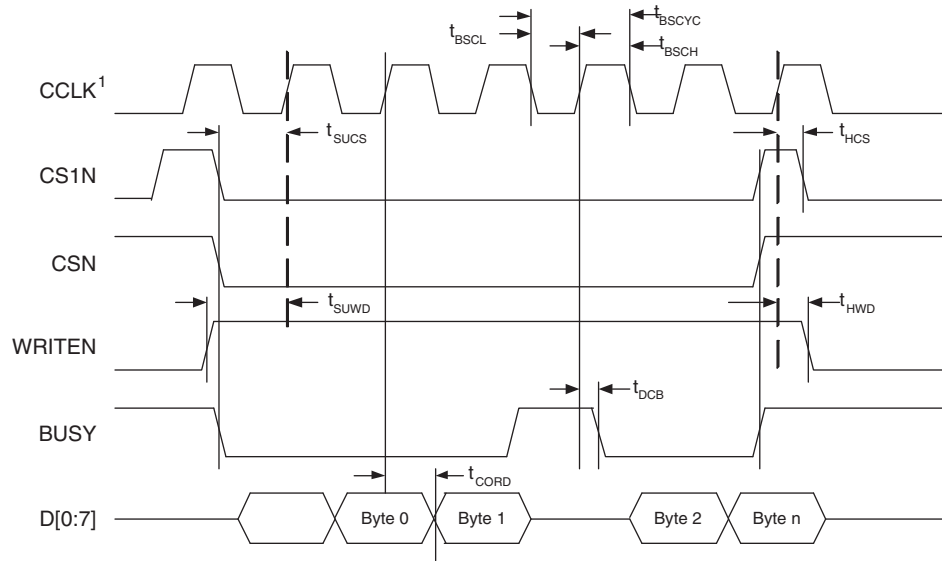

1. In Master Parallel Mode the FPGA provides CCLK. In Slave Parallel Mode the external device provides CCLK.

Figure 3-13. sysCONFIG Parallel Port Write Cycle

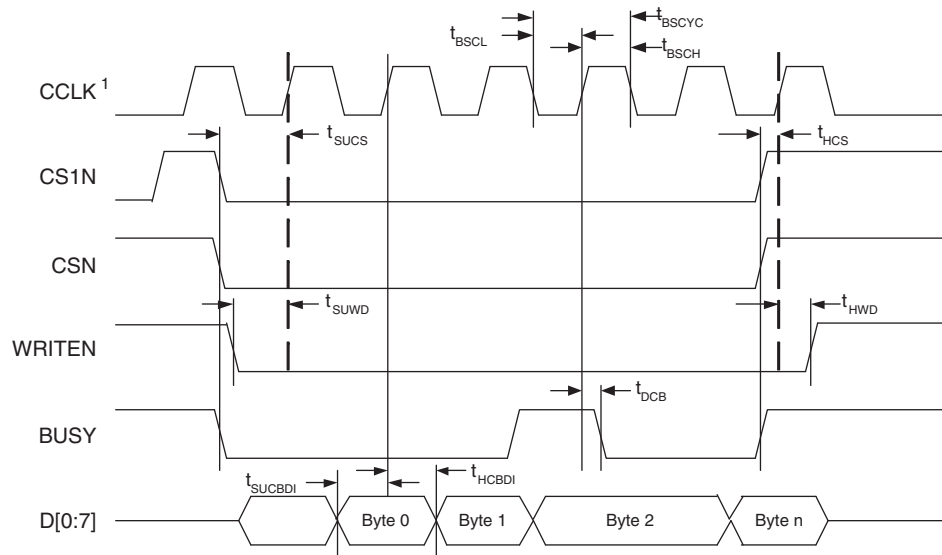

1. In Master Parallel Mode the FPGA provides CCLK. In Slave Parallel Mode the external device provides CCLK.

Figure 3-14. sysCONFIG Master Serial Port Timing

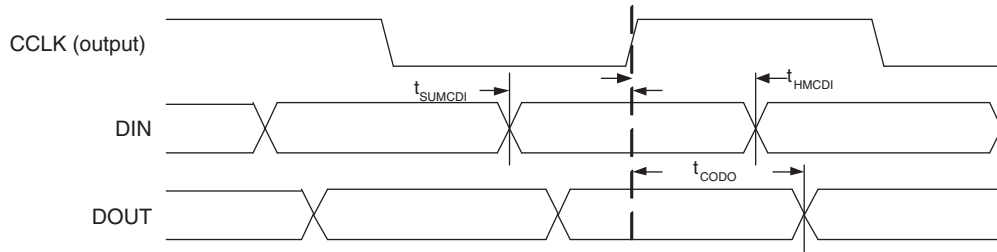

Figure 3-15. sysCONFIG Slave Serial Port Timing

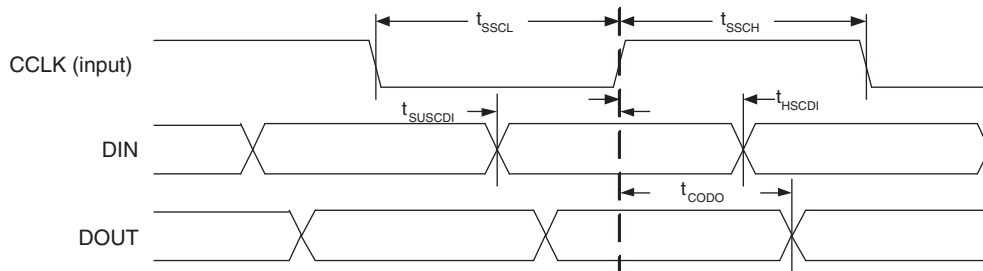
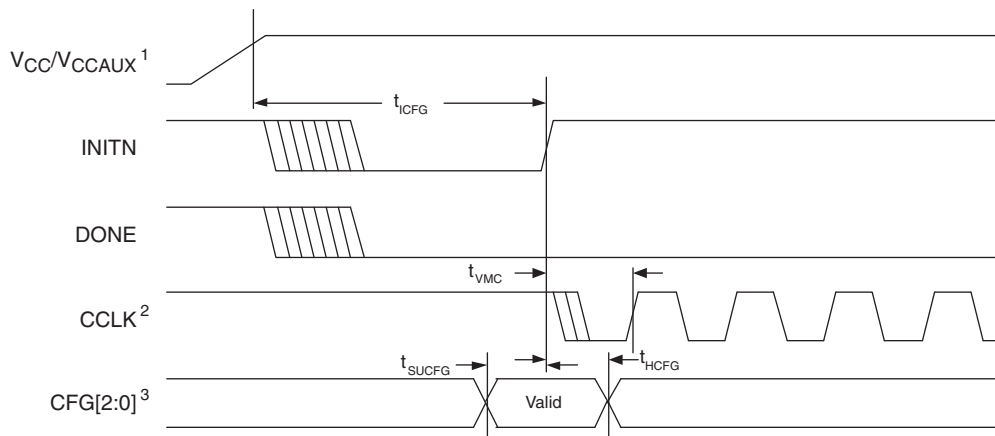
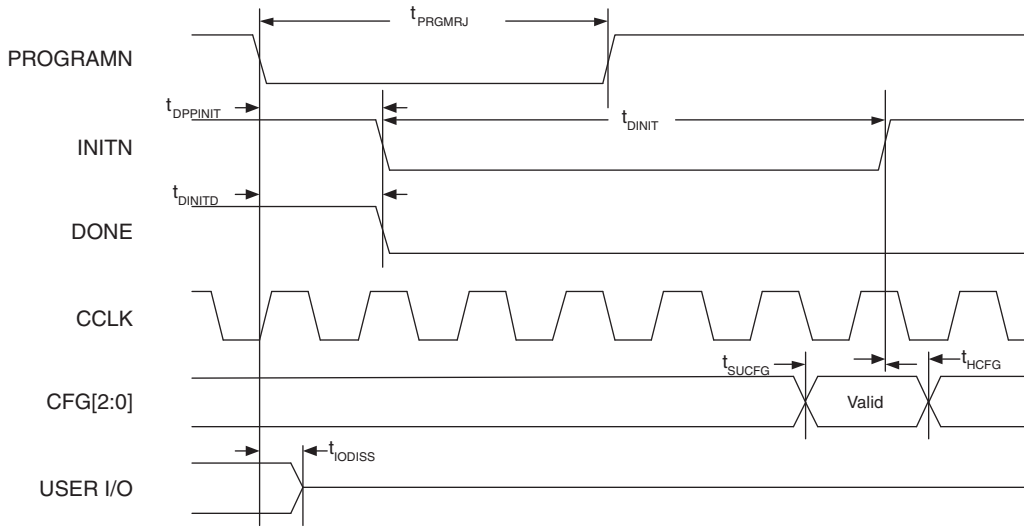

Figure 3-16. Power-On-Reset (POR) Timing



1. Time taken from VCC or VCCAUX, whichever is the last to reach its VMIN.
2. Device is in a Master Mode.
3. The CFG pins are normally static (hard wired).

Figure 3-17. Configuration from PROGRAMN Timing



1. The CFG pins are normally static (hard wired)

Figure 3-18. Wake-Up Timing

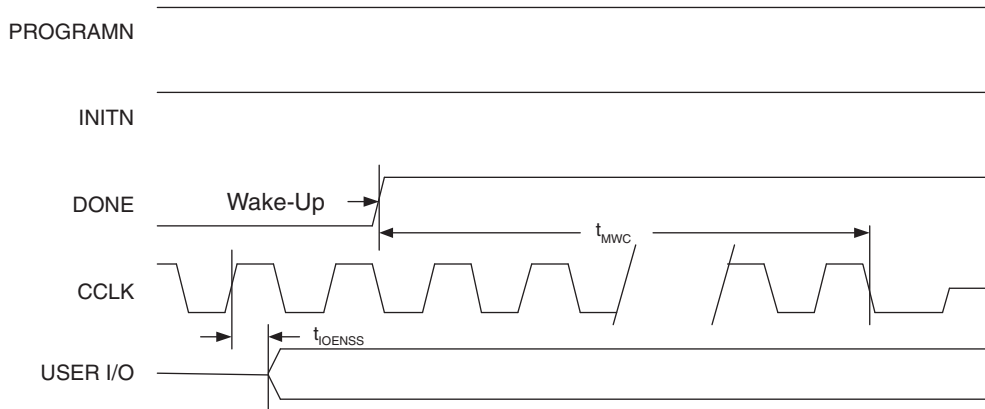
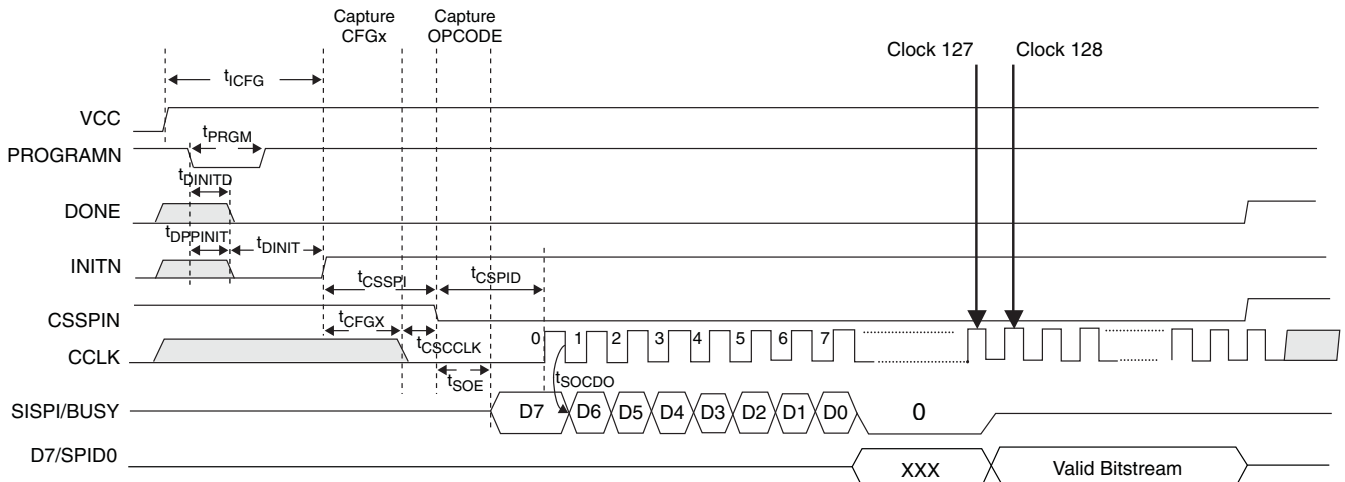

Figure 3-19. sysCONFIG SPI Port Sequence





## JTAG Port Timing Specifications

Over Recommended Operating Conditions

Symbol	Parameter	Min	Max	Units
$f_{MAX}$	TCK clock frequency	—	25	MHz
$t_{BTCP}$	TCK [BSCAN] clock pulse width	40	—	ns
$t_{BTCPH}$	TCK [BSCAN] clock pulse width high	20	—	ns
$t_{BTCPL}$	TCK [BSCAN] clock pulse width low	20	—	ns
$t_{BTS}$	TCK [BSCAN] setup time	8	—	ns
$t_{BTH}$	TCK [BSCAN] hold time	10	—	ns
$t_{BTRF}$	TCK [BSCAN] rise/fall time	50	—	mV/ns
$t_{BTCO}$	TAP controller falling edge of clock to valid output	—	10	ns
$t_{BTCODIS}$	TAP controller falling edge of clock to valid disable	—	10	ns
$t_{BTCOEN}$	TAP controller falling edge of clock to valid enable	—	10	ns
$t_{BTCRS}$	BSCAN test capture register setup time	8	—	ns
$t_{BTCRH}$	BSCAN test capture register hold time	25	—	ns
$t_{BUTCO}$	BSCAN test update register, falling edge of clock to valid output	—	25	ns
$t_{BTUODIS}$	BSCAN test update register, falling edge of clock to valid disable	—	25	ns
$t_{BTUPOEN}$	BSCAN test update register, falling edge of clock to valid enable	—	25	ns

Timing v.G 0.30

Figure 3-20. JTAG Port Timing Waveforms

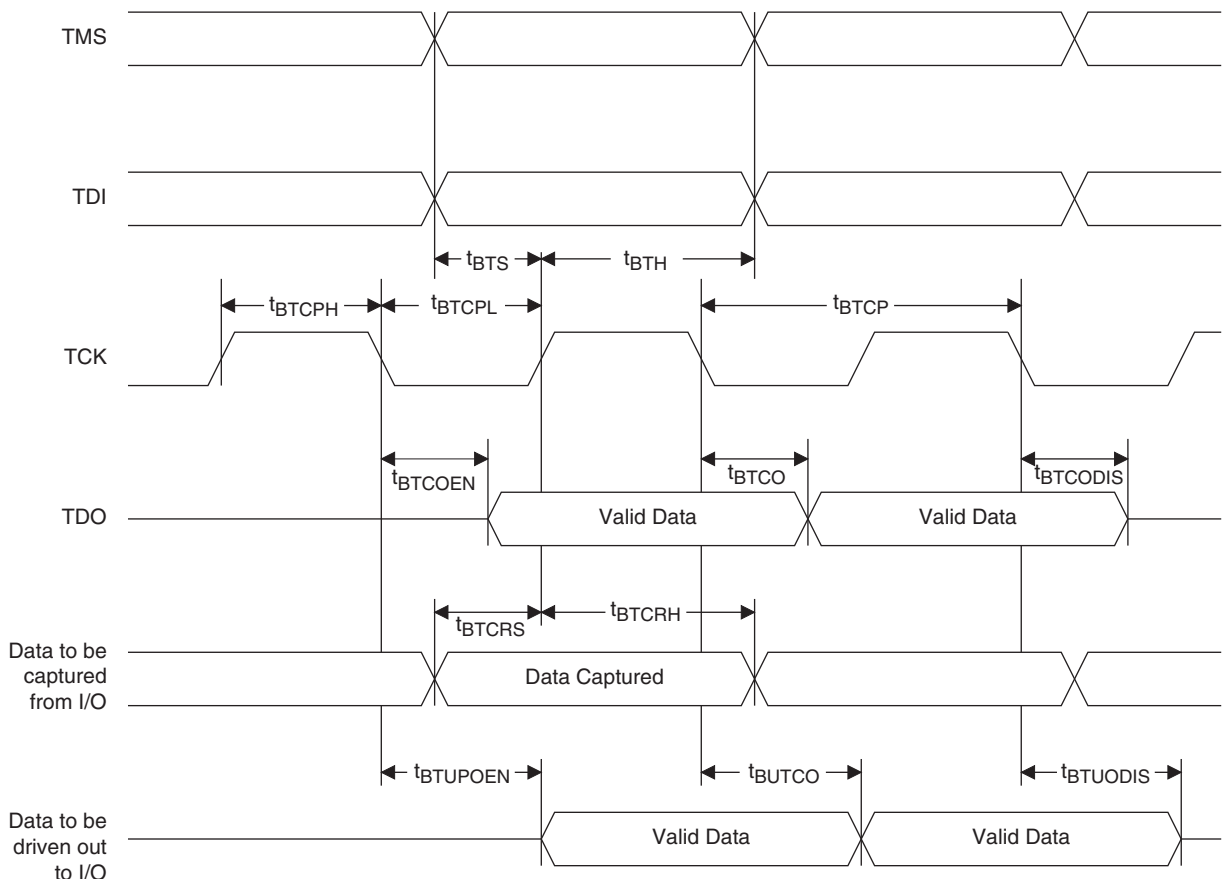

### Switching Test Conditions

Figure 3-21 shows the output test load that is used for AC testing. The specific values for resistance, capacitance, voltage, and other test conditions are shown in Table 3-6.

**Figure 3-21. Output Test Load, LVTTTL and LVCMOS Standards**

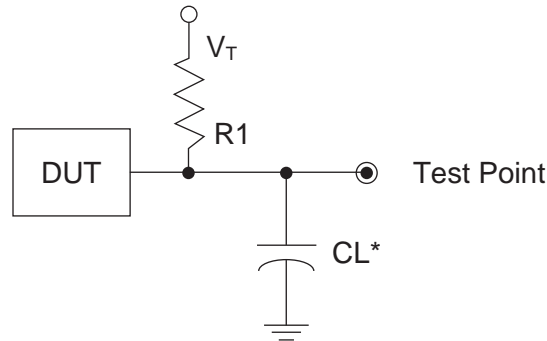

\*CL Includes Test Fixture and Probe Capacitance

**Table 3-6. Test Fixture Required Components, Non-Terminated Interfaces**

Test Condition	R <sub>1</sub>	C <sub>L</sub>	Timing Ref.	V <sub>T</sub>
LVTTTL and other LVCMOS settings (L -> H, H -> L)	∞	0pF	LVCMOS 3.3 = 1.5V	—
			LVCMOS 2.5 = V <sub>CCIO</sub> /2	—
			LVCMOS 1.8 = V <sub>CCIO</sub> /2	—
			LVCMOS 1.5 = V <sub>CCIO</sub> /2	—
			LVCMOS 1.2 = V <sub>CCIO</sub> /2	—
LVCMOS 2.5 I/O (Z -> H)	188Ω	0pF	V <sub>CCIO</sub> /2	V <sub>OL</sub>
LVCMOS 2.5 I/O (Z -> L)			V <sub>CCIO</sub> /2	V <sub>OH</sub>
LVCMOS 2.5 I/O (H -> Z)			V <sub>OH</sub> - 0.15	V <sub>OL</sub>
LVCMOS 2.5 I/O (L -> Z)			V <sub>OL</sub> + 0.15	V <sub>OH</sub>

Note: Output test conditions for all other interfaces are determined by the respective standards.

### Signal Descriptions

Signal Name	I/O	Description
<b>General Purpose</b>		
P[Edge] [Row/Column Number*]_[A/B]	I/O	<p>[Edge] indicates the edge of the device on which the pad is located. Valid edge designations are L (Left), B (Bottom), R (Right), T (Top).</p> <p>[Row/Column Number] indicates the PFU row or the column of the device on which the PIC exists. When Edge is T (Top) or (Bottom), only need to specify Row Number. When Edge is L (Left) or R (Right), only need to specify Column Number.</p> <p>[A/B] indicates the PIO within the PIC to which the pad is connected.</p> <p>Some of these user-programmable pins are shared with special function pins. These pin when not used as special purpose pins can be programmed as I/Os for user logic.</p> <p>During configuration the user-programmable I/Os are tri-stated with an internal pull-up resistor enabled. If any pin is not used (or not bonded to a package pin), it is also tri-stated with an internal pull-up resistor enabled after configuration.</p>
GSRN	I	Global RESET signal (active low). Any I/O pin can be GSRN.
NC	—	No connect.
GND	—	Ground. Dedicated pins.
V <sub>CC</sub>	—	Power supply pins for core logic. Dedicated pins.
V <sub>CCAUX</sub>	—	Auxiliary power supply pin. It powers all the differential and referenced input buffers. Dedicated pins.
V <sub>CCIOx</sub>	—	Power supply pins for I/O bank x. Dedicated pins.
V <sub>REF1_x</sub> , V <sub>REF2_x</sub>	—	Reference supply pins for I/O bank x. Pre-determined pins in each bank are assigned as V <sub>REF</sub> inputs. When not used, they may be used as I/O pins.
XRES	—	10K ohm +/-1% resistor must be connected between this pad and ground.
V <sub>CCPLL</sub>	—	Power supply pin for PLL. Applicable to ECP/EC33 device.
<b>PLL and Clock Functions</b> (Used as user programmable I/O pins when not in use for PLL or clock pins)		
[LOC][num]_PLL[T, C]_IN_A	I	Reference clock (PLL) input pads: ULM, LLM, URM, LRM, num = row from center, T = true and C = complement, index A,B,C...at each side.
[LOC][num]_PLL[T, C]_FB_A	I	Optional feedback (PLL) input pads: ULM, LLM, URM, LRM, num = row from center, T = true and C = complement, index A,B,C...at each side.
PCLK[T, C]_[n:0]_[3:0]	I	Primary Clock pads, T = true and C = complement, n per side, indexed by bank and 0,1,2,3 within bank.
[LOC]DQS[num]	I	DQS input pads: T (Top), R (Right), B (Bottom), L (Left), DQS, num = ball function number. Any pad can be configured to be output.
<b>Test and Programming</b> (Dedicated pins)		
TMS	I	Test Mode Select input, used to control the 1149.1 state machine. Pull-up is enabled during configuration.
TCK	I	Test Clock input pin, used to clock the 1149.1 state machine. No pull-up enabled.

**Signal Descriptions (Cont.)**

Signal Name	I/O	Description
TDI	I	Test Data in pin. Used to load data into device using 1149.1 state machine. After power-up, this TAP port can be activated for configuration by sending appropriate command. (Note: once a configuration port is selected it is locked. Another configuration port cannot be selected until the power-up sequence). Pull-up is enabled during configuration.
TDO	O	Output pin. Test Data out pin used to shift data out of device using 1149.1.
V <sub>CCJ</sub>	—	V <sub>CCJ</sub> - The power supply pin for JTAG Test Access Port.
<b>Configuration Pads</b> (used during sysCONFIG)		
CFG[2:0]	I	Mode pins used to specify configuration modes values latched on rising edge of INITN. During configuration, a pull-up is enabled. These are dedicated pins.
INITN	I/O	Open Drain pin. Indicates the FPGA is ready to be configured. During configuration, a pull-up is enabled. It is a dedicated pin.
PROGRAMN	I	Initiates configuration sequence when asserted low. This pin always has an active pull-up. This is a dedicated pin.
DONE	I/O	Open Drain pin. Indicates that the configuration sequence is complete, and the startup sequence is in progress. This is a dedicated pin.
CCLK	I/O	Configuration Clock for configuring an FPGA in sysCONFIG mode.
BUSY/SISPI	I/O	Read control command in SPI3 or SPIX mode.
CSN	I	sysCONFIG chip select (Active low). During configuration, a pull-up is enabled.
CS1N	I	sysCONFIG chip select (Active low). During configuration, a pull-up is enabled.
WRITEN	I	Write Data on Parallel port (Active low).
D[7:0]/SPID[0:7]	I/O	sysCONFIG Port Data I/O.
DOUT/CSON	O	Output for serial configuration data (rising edge of CCLK) when using sysCONFIG port.
DI/CSSPIN	I/O	Input for serial configuration data (clocked with CCLK) when using sysCONFIG port. During configuration, a pull-up is enabled. Output when used in SPI/SPIX modes.

**PICs and DDR Data (DQ) Pins Associated with the DDR Strobe (DQS) Pin**

PICs Associated with DQS Strobe	PIO Within PIC	DDR Strobe (DQS) and Data (DQ) Pins
P[Edge] [n-4]	A	DQ
	B	DQ
P[Edge] [n-3]	A	DQ
	B	DQ
P[Edge] [n-2]	A	DQ
	B	DQ
P[Edge] [n-1]	A	DQ
	B	DQ
P[Edge] [n]	A	[Edge]DQSn
	B	DQ
P[Edge] [n+1]	A	DQ
	B	DQ
P[Edge] [n+2]	A	DQ
	B	DQ
P[Edge] [n+3]	A	DQ
	B	DQ

Notes:

1. "n" is a Row/Column PIC number
2. The DDR interface is designed for memories that support one DQS strobe per eight bits of data. In some packages, all the potential DDR data (DQ) pins may not be available.
3. PIC numbering definitions are provided in the "Signal Names" column of the Signal Descriptions table.

Pin Information Summary

Pin Type		LFEC1			LFEC3				LFECP6/EC6				LFECP/EC10		
		100-TQFP	144-TQFP	208-PQFP	100-TQFP	144-TQFP	208-PQFP	256-fpBGA	144-TQFP	208-PQFP	256-fpBGA	484-fpBGA	208-PQFP	256-fpBGA	484-fpBGA
Single Ended User I/O		67	97	112	67	97	145	160	97	147	195	224	147	195	288
Differential Pair User I/O		29	46	56	29	46	72	80	46	72	97	112	72	97	144
Configu-ration	Dedicated	13	13	13	13	13	13	13	13	13	13	13	13	13	13
	Muxed	48	48	48	48	48	48	48	48	48	48	48	56	56	56
TAP		5	5	5	5	5	5	5	5	5	5	5	5	5	5
Dedicated (total without supplies)		80	110	160	80	110	160	208	110	160	208	373	160	208	373
V <sub>CC</sub>		2	3	3	2	3	3	10	4	4	10	20	6	10	20
V <sub>CCAUX</sub>		2	2	2	4	4	4	4	2	4	2	12	4	2	12
V <sub>CCPLL</sub>		0	0	0	0	0	0	0	0	0	0	0	0	0	0
V <sub>CCIO</sub>	Bank0	1	2	2	1	2	3	2	2	3	2	4	3	2	4
	Bank1	1	2	2	1	2	2	2	2	2	2	4	2	2	4
	Bank2	1	1	1	2	2	2	2	1	2	2	4	2	2	4
	Bank3	1	2	2	1	2	2	2	2	2	2	4	2	2	4
	Bank4	1	2	2	1	2	2	2	2	2	2	4	2	2	4
	Bank5	1	2	2	1	2	2	2	2	3	2	4	3	2	4
	Bank6	1	2	2	1	2	2	2	2	2	2	4	2	2	4
	Bank7	1	1	1	2	2	2	2	1	2	2	4	2	2	4
GND, GND0-GND7		8	13	13	8	13	16	20	14	18	20	44	20	20	44
NC		0	2	51	0	2	9	35	0	4	0	139	0	0	75
Single Ended/Differen-tial I/O Pair per Bank	Bank 0	11/5	14/7	16/8	11/5	14/7	26/13	32/16	14/7	26/13	32/16	32/16	26/13	32/16	48/24
	Bank 1	11/5	13/6	16/8	11/5	13/6	16/8	16/8	13/6	17/8	18/9	32/16	17/8	18/9	32/16
	Bank 2	3/1	8/4	8/4	3/1	8/4	14/7	16/8	8/4	14/7	16/8	16/8	14/7	16/8	32/16
	Bank 3	8/4	13/6	16/8	8/4	13/6	16/8	16/8	13/6	16/8	32/16	32/16	16/8	32/16	32/16
	Bank 4	12/4	14/6	16/8	12/4	14/6	16/8	16/8	14/6	17/8	17/8	32/16	17/8	17/8	32/16
	Bank 5	9/4	13/6	16/8	9/4	13/6	26/13	32/16	13/6	26/13	32/16	32/16	26/13	32/16	48/24
	Bank 6	5/2	14/7	16/8	5/2	14/7	16/8	16/8	14/7	16/8	32/16	32/16	16/8	32/16	32/16
	Bank 7	8/4	8/4	8/4	8/4	8/4	15/7	16/8	8/4	15/7	16/8	16/8	15/7	16/8	32/16
V <sub>CCJ</sub>		1	1	1	1	1	1	1	1	1	1	1	1	1	1

Note: During configuration the user-programmable I/Os are tri-stated with an internal pull-up resistor enabled. If any pin is not used (or not bonded to a package pin), it is also tri-stated with an internal pull-up resistor enabled after configuration.

## Pin Information Summary (Cont.)

Pin Type		LFEC/EC15		LFEC/EC20		LFEC/EC33	
		256-fpBGA	484-fpBGA	484-fpBGA	672-fpBGA	484-fpBGA	672-fpBGA
Single Ended User I/O		195	352	360	400	360	496
Differential Pair User I/O		97	176	180	200	180	248
Configuration	Dedicated	13	13	13	13	13	13
	Muxed	56	56	56	56	56	56
TAP		5	5	5	5	5	5
Dedicated (total without supplies)		208	373	373	509	373	509
V <sub>CC</sub>		10	20	20	32	16	28
V <sub>CCAUX</sub>		2	12	12	20	12	20
V <sub>CCPLL</sub>		0	0	0	0	4	4
V <sub>CCIO</sub>	Bank0	2	4	4	6	4	6
	Bank1	2	4	4	6	4	6
	Bank2	2	4	4	6	4	6
	Bank3	2	4	4	6	4	6
	Bank4	2	4	4	6	4	6
	Bank5	2	4	4	6	4	6
	Bank6	2	4	4	6	4	6
	Bank7	2	4	4	6	4	6
GND, GND0-GND7		20	44	44	63	44	63
NC		0	11	3	96	3	0
Single Ended/ Differential I/O Pair per Bank	Bank0	32/16	48/24	48/24	64/32	48/24	64/32
	Bank1	18/9	48/24	48/24	48/24	48/24	64/32
	Bank2	16/8	40/20	40/20	40/20	40/20	56/28
	Bank3	32/16	40/20	44/22	48/24	44/22	64/32
	Bank4	17/8	48/24	48/24	48/24	48/24	64/32
	Bank5	32/16	48/24	48/24	64/32	48/24	64/32
	Bank6	32/16	40/20	44/22	48/24	44/22	64/32
	Bank7	16/8	40/20	40/20	40/20	40/20	56/28
V <sub>CCJ</sub>		1	1	1	1	1	1

Note: During configuration the user-programmable I/Os are tri-stated with an internal pull-up resistor enabled. If any pin is not used (or not bonded to a package pin), it is also tri-stated with an internal pull-up resistor enabled after configuration.

## Power Supply and NC Connections

Signals	100 TQFP	144 TQFP	208 PQFP	256 fpBGA
VCC	12, 64	<b>EC1, EC3:</b> 13, 92, 99 <b>ECP/EC6:</b> 11, 13, 92, 99	<b>EC1, EC3:</b> 26, 128, 135 <b>ECP/EC6:</b> 24, 26, 128, 135 <b>ECP/EC10:</b> 5, 24, 26, 128, 135, 152	E12, E5, E8, M12, M5, M9, F6, F11, L11, L6
VCCIO0	100	136, 143	<b>EC1:</b> 187, 208 <b>EC3, ECP/EC6, ECP/EC10:</b> 187, 197, 208	F7, F8
VCCIO1	86	110, 125	157, 176	F9, F10
VCCIO2	73	108	<b>EC1:</b> 155 <b>EC3, ECP/EC6, ECP/EC10:</b> 145, 155	G11, H11
VCCIO3	56	73, 84	106, 120	J11, K11
VCCIO4	38	55, 71	85, 104	L9, L10
VCCIO5	26	38, 44	<b>EC1:</b> 53, 74 <b>EC2, ECP/EC6, ECP/EC10:</b> 53, 64, 74	L7, L8
VCCIO6	24	24, 36	37, 51	J6, K6
VCCIO7	2	1	<b>EC1:</b> 2 <b>EC3, ECP/EC6, ECP/EC10:</b> 2, 13	G6, H6
VCCJ	18	19	32	L4
VCCAUX	37, 87	54, 126	<b>EC1:</b> 84, 177 <b>EC3, ECP/EC6, ECP/EC10:</b> 22, 84, 136, 177	B15, R2
VCCPLL	—	—	—	—
GND, GND0-GND7	1, 14, 25, 35, 51, 68, 74, 89	<b>EC1, EC3:</b> 15, 28, 37, 52, 63, 72, 80, 96, 98, 109, 117, 128, 144 <b>ECP/EC6:</b> 12, 15, 28, 37, 52, 63, 72, 80, 96, 98, 109, 117, 128, 144	<b>EC1:</b> 1, 28, 41, 52, 82, 93, 105, 116, 132, 134, 156, 168, 179 <b>EC3:</b> 1, 28, 41, 52, 72, 82, 93, 105, 116, 132, 134, 138, 156, 168, 179, 189 <b>ECP/EC6:</b> 1, 18, 25, 28, 41, 52, 72, 82, 93, 105, 116, 132, 134, 138, 156, 168, 179, 189 <b>ECP/EC10:</b> 1, 6, 18, 25, 28, 41, 52, 72, 82, 93, 105, 116, 132, 134, 138, 151, 156, 168, 179, 189	A1, A16, G10, G7, G8, G9, H10, H7, H8, H9, J10, J7, J8, J9, K10, K7, K8, K9, T1, T16
NC	—	<b>EC1, EC3:</b> 11, 12 <b>ECP6/EC6:</b> None	<b>EC1:</b> 5, 6, 7, 8, 9, 10, 11, 12, 13, 14, 18, 22, 24, 25, 54, 55, 56, 57, 58, 59, 60, 61, 62, 63, 64, 72, 103, 136, 138, 144, 145, 146, 147, 148, 149, 150, 151, 152, 158, 189, 197, 198, 199, 200, 201, 202, 203, 204, 205, 206, 207 <b>EC3:</b> 5, 6, 18, 24, 25, 103, 151, 152, 158 <b>ECP/EC6:</b> 5, 6, 151, 152 <b>ECP/EC10:</b> None	<b>EC3:</b> G5, H5, F2, F1, H4, H3, G2, G1, J4, J3, J5, K5, H2, H1, J2, J1, R12, H16, H15, G16, G15, K12, J12, J14, J15, F16, F15, J13, H13, H14, G14, E16, E15, B13, C13 <b>ECP/EC10:</b> None <b>ECP/EC15:</b> None



**Power Supply and NC Connections (Cont.)**

Signals	484 fpBGA	672 fpBGA
VCC	J16, J7, K16, K17, K6, K7, L17, L6, M17, M6, N16, N17, N6, N7, P16, P7, J6, J17, P6, P17	H10, H11, H16, H17, H18, H19, H8, H9, J18, J9, K8, L19, M19, N7, R20, R7, T19, V18, V8, V9, W10, W11, W16, W17, W18, W19, W8, W9, K19, L8, U19, U8
VCCIO0	G11, H10, H11, H9	H12, H13, J10, J11, J12, J13
VCCIO1	G12, H12, H13, H14	H14, H15, J14, J15, J16, J17
VCCIO2	J15, K15, L15, L16	K17, K18, L18, M18, N18, N19
VCCIO3	M15, M16, N15, P15	P18, P19, R18, R19, T18, U18
VCCIO4	R12, R13, R14, T12	V14, V15, V16, V17, W14, W15
VCCIO5	R10, R11, R9, T11	V10, V11, V12, V13, W12, W13
VCCIO6	M7, M8, N8, P8	P8, P9, R8, R9, T9, U9
VCCIO7	J8, K8, L7, L8	K9, L9, M8, M9, N8, N9
VCCJ	U2	U6
VCCAUX	G15, G16, G7, G8, H16, H7, R16, R7, T15, T16, T7, T8	G13, H20, H7, J19, J8, K7, L20, M20, M7, N20, P20, P7, T20, T7, T8, V19, V7, W20, Y13, Y7
VCCPLL	<b>ECP/EC20:</b> None <b>ECP/EC33:</b> J6, J17, P6, P17	<b>ECP/EC20:</b> None <b>ECP/EC33:</b> K19, L8, U19, U8
GND, GND0-GND7	A1, A22, AB1, AB22, H15, H8, J10, J11, J12, J13, J14, J9, K10, K11, K12, K13, K14, K9, L10, L11, L12, L13, L14, L9, M10, M11, M12, M13, M14, M9, N10, N11, N12, N13, N14, N9, P10, P11, P12, P13, P14, P9, R15, R8	K10, K11, K12, K13, K14, K15, K16, L10, L11, L12, L13, L14, L15, L16, L17, M10, M11, M12, M13, M14, M15, M16, M17, N10, N11, N12, N13, N14, N15, N16, N17, P10, P11, P12, P13, P14, P15, P16, P17, R10, R11, R12, R13, R14, R15, R16, R17, T10, T11, T12, T13, T14, T15, T16, T17, U10, U11, U12, U13, U14, U15, U16, U17
NC	<b>ECP/EC6:</b> C3, B2, E5, F5, D3, C2, F4, G4, E3, D2, B1, C1, F3, E2, G5, H6, G3, H4, J5, H5, F2, F1, E1, D1, R6, P5, P3, P4, R1, R2, R5, R4, T1, T2, R3, T3, V7, T6, V8, U7, W5, U6, AA3, AB3, Y6, V6, AA5, W6, Y5, Y4, AA4, AB4, W16, U15, V16, U16, Y17, V17, AB20, AA19, Y16, W17, AA20, Y19, Y18, W18, T17, U17, T18, R17, R19, R18, U22, T22, R21, R22, P20, N20, P19, P18, E21, D22, G21, G20, J18, H19, J19, H20, H17, H18, D21, C22, G19, G18, F20, F19, E20, D20, C21, C20, F18, E18, B22, B21, G17, F17, D18, C18, C19, B20, D17, C16, B19, A20, E17, C17, F16, E16, F15, D16, A4, B4, C4, C5, D6, B5, E6, C6, A3, B3, F6, D5, F7, E8, G6, E7, A2, AB2, A21 <b>ECP/EC10:</b> G5, H6, G3, H4, J5, H5, F2, F1, R6, P5, P3, P4, R2, R1, R5, R4, T1, T2, R3, T3, W16, U15, V16, U16, Y17, V17, AB20, AA19, Y16, W17, AA20, Y19, Y18, W18, T17, U17, T18, R17, R19, R18, U22, T22, R21, R22, P20, N20, P19, P18, G21, G20, J18, H19, J19, H20, H17, H18, G17, F17, D18, C18, C19, B20, D17, C16, B19, A20, E17, C17, F16, E16, F15, D16, A2, AB2, A21 <b>ECP/EC15:</b> T1, T2, R3, T3, T18, R17, R19, R18, A2, AB2, A21 <b>ECP/EC20:</b> A2, AB2, A21 <b>ECP/EC33:</b> A2, AB2, A21	<b>ECP/EC20:</b> E5, D5, F4, F5, C3, D3, C2, B2, H6, J7, G5, H5, H3, J3, H2, J2, AA2, AA3, W5, Y5, Y6, W7, AA4, AB3, AC2, AC3, AA5, AB5, AD3, AD2, AE1, AD1, AD19, AD20, AC19, AB19, AD21, AC20, AF25, AE25, AB21, AB20, AE24, AD23, AD22, AC21, AC22, AB22, AD24, AD25, AE26, AD26, Y20, Y19, AA23, AA22, AB23, AB24, Y21, AA21, Y23, Y22, AA24, Y24, J21, J22, J23, H22, G26, F26, E26, E25, F24, F23, E24, D24, E22, F22, E21, D22, G20, F20, D21, C21, C23, C22, B23, C24, D20, E19, B25, B24, B26, A25, C20, C19 <b>ECP/EC33:</b> None

**LFEC1, LFEC3 Logic Signal Connections: 100 TQFP**

Pin Number	LFEC1				LFEC3			
	Pin Function	Bank	LVDS	Dual Function	Pin Function	Bank	LVDS	Dual Function
1*	GND0 GND7	-			GND0 GND7	-		
2	VCCIO7	7			VCCIO7	7		
3	PL2A	7	T	VREF2_7	PL2A	7	T	VREF2_7
4	PL2B	7	C	VREF1_7	PL2B	7	C	VREF1_7
5	PL3A	7	T		PL7A	7	T	
6	PL3B	7	C		PL7B	7	C	
7	PL4A	7	T		PL8A	7	T	
8	PL4B	7	C		PL8B	7	C	
9	PL5A	7	T	PCLKT7_0	PL9A	7	T	PCLKT7_0
10	PL5B	7	C	PCLKC7_0	PL9B	7	C	PCLKC7_0
11	XRES	6			XRES	6		
12	VCC	-			VCC	-		
13	TCK	6			TCK	6		
14	GND	-			GND	-		
15	TDI	6			TDI	6		
16	TMS	6			TMS	6		
17	TDO	6			TDO	6		
18	VCCJ	6			VCCJ	6		
19	PL7A	6	T	LLM0_PLLT_IN_A	PL11A	6	T	LUM0_PLLT_IN_A
20	PL7B	6	C	LLM0_PLLC_IN_A	PL11B	6	C	LUM0_PLLC_IN_A
21	PL8A	6	T	LLM0_PLLT_FB_A	PL12A	6	T	LUM0_PLLT_FB_A
22	PL8B	6	C	LLM0_PLLC_FB_A	PL12B	6	C	LUM0_PLLC_FB_A
23	PL14A	6		VREF1_6	PL18A	6		VREF1_6
24	VCCIO6	6			VCCIO6	6		
25*	GND5 GND6	-			GND5 GND6	-		
26	VCCIO5	5			VCCIO5	5		
27	PB2A	5	T		PB10A	5	T	
28	PB2B	5	C		PB10B	5	C	
29	PB3A	5	T		PB11A	5	T	
30	PB3B	5	C		PB11B	5	C	
31	PB6A	5		BDQS6	PB14A	5		BDQS14
32	PB8A	5	T	VREF2_5	PB16A	5	T	VREF2_5
33	PB8B	5	C	VREF1_5	PB16B	5	C	VREF1_5
34	PB9A	5	T	PCLKT5_0	PB17A	5	T	PCLKT5_0
35	GND5	5			GND5	5		
36	PB9B	5	C	PCLKC5_0	PB17B	5	C	PCLKC5_0
37	VCCAUX	-			VCCAUX	-		
38	VCCIO4	4			VCCIO4	4		
39	PB10A	4	T	WRITEN	PB18A	4	T	WRITEN
40	PB10B	4	C	CS1N	PB18B	4	C	CS1N

**LFEC1, LFEC3 Logic Signal Connections: 100 TQFP (Cont.)**

Pin Number	LFEC1				LFEC3			
	Pin Function	Bank	LVDS	Dual Function	Pin Function	Bank	LVDS	Dual Function
41	PB11A	4	T	VREF1_4	PB19A	4	T	VREF1_4
42	PB11B	4	C	CSN	PB19B	4	C	CSN
43	PB12B	4		D0/SPID7	PB20B	4		D0/SPID7
44	PB13A	4	T	D2/SPID5	PB21A	4	T	D2/SPID5
45	PB13B	4	C	D1/SPID6	PB21B	4	C	D1/SPID6
46	PB14A	4	T	BDQS14	PB22A	4	T	BDQS22
47	PB14B	4	C	D3/SPID4	PB22B	4	C	D3/SPID4
48	PB15B	4		D4/SPID3	PB23B	4		D4/SPID3
49	PB16B	4		D5/SPID2	PB24B	4		D5/SPID2
50	PB17B	4		D6/SPID1	PB25B	4		D6/SPID1
51*	GND3 GND4	-			GND3 GND4	-		
52	PR10B	3	C	RLM0_PLLC_FB_A	PR14B	3	C	RLM0_PLLC_FB_A
53	PR10A	3	T	RLM0_PLLT_FB_A	PR14A	3	T	RLM0_PLLT_FB_A
54	PR9B	3	C	RLM0_PLLC_IN_A	PR13B	3	C	RLM0_PLLC_IN_A
55	PR9A	3	T	RLM0_PLLT_IN_A	PR13A	3	T	RLM0_PLLT_IN_A
56	VCCIO3	3			VCCIO3	3		
57	PR8B	3	C	DI/CSSPIN	PR12B	3	C	DI/CSSPIN
58	PR8A	3	T	DOUT/CSON	PR12A	3	T	DOUT/CSON
59	PR7B	3	C	BUSY/SISPI	PR11B	3	C	BUSY/SISPI
60	PR7A	3	T	D7/SPID0	PR11A	3	T	D7/SPID0
61	CFG2	3			CFG2	3		
62	CFG1	3			CFG1	3		
63	CFG0	3			CFG0	3		
64	VCC	-			VCC	-		
65	PROGRAMN	3			PROGRAMN	3		
66	CCLK	3			CCLK	3		
67	INITN	3			INITN	3		
68	GND	-			GND	-		
69	DONE	3			DONE	3		
70	PR5B	2	C	PCLKC2_0	PR9B	2	C	PCLKC2_0
71	PR5A	2	T	PCLKT2_0	PR9A	2	T	PCLKT2_0
72	PR2B	2		VREF1_2	PR2B	2		VREF1_2
73	VCCIO2	2			VCCIO2	2		
74	GND2	2			GND2	2		
75	PT17B	1	C		PT25B	1	C	
76	PT17A	1	T		PT25A	1	T	
77	PT14B	1	C		PT22B	1	C	
78	PT14A	1	T	TDQS14	PT22A	1	T	TDQS22
79	PT13A	1			PT21A	1		
80	PT12B	1	C		PT20B	1	C	
81	PT12A	1	T		PT20A	1	T	

**LFEC1, LFEC3 Logic Signal Connections: 100 TQFP (Cont.)**

Pin Number	LFEC1				LFEC3			
	Pin Function	Bank	LVDS	Dual Function	Pin Function	Bank	LVDS	Dual Function
82	PT11B	1	C	VREF2_1	PT19B	1	C	VREF2_1
83	PT11A	1	T	VREF1_1	PT19A	1	T	VREF1_1
84	PT10B	1	C		PT18B	1	C	
85	PT10A	1	T		PT18A	1	T	
86	VCCIO1	1			VCCIO1	1		
87	VCCAUX	-			VCCAUX	-		
88	PT9B	0	C	PCLKC0_0	PT17B	0	C	PCLKC0_0
89	GND0	0			GND0	0		
90	PT9A	0	T	PCLKT0_0	PT17A	0	T	PCLKT0_0
91	PT8B	0	C	VREF1_0	PT16B	0	C	VREF1_0
92	PT8A	0	T	VREF2_0	PT16A	0	T	VREF2_0
93	PT7B	0			PT15B	0		
94	PT6B	0	C		PT14B	0	C	
95	PT6A	0	T	TDQS6	PT14A	0	T	TDQS14
96	PT4B	0	C		PT12B	0	C	
97	PT4A	0	T		PT12A	0	T	
98	PT2B	0	C		PT10B	0	C	
99	PT2A	0	T		PT10A	0	T	
100	VCCIO0	0			VCCIO0	0		

\*Double bonded to the pin.

**LFEC1, LFEC3, LFEC6/EC6 Logic Signal Connections: 144 TQFP**

Pin Number	LFEC1				LFEC3				LFEC6/EC6			
	Pin Function	Bank	LVDS	Dual Function	Pin Function	Bank	LVDS	Dual Function	Pin Function	Bank	LVDS	Dual Function
1	VCCIO7	7			VCCIO7	7			VCCIO7	7		
2	PL2A	7	T	VREF2_7	PL2A	7	T	VREF2_7	PL2A	7	T	VREF2_7
3	PL2B	7	C	VREF1_7	PL2B	7	C	VREF1_7	PL2B	7	C	VREF1_7
4	PL3A	7	T		PL7A	7	T		PL7A	7	T	
5	PL3B	7	C		PL7B	7	C		PL7B	7	C	
6	PL4A	7	T		PL8A	7	T		PL8A	7	T	
7	PL4B	7	C		PL8B	7	C		PL8B	7	C	
8	PL5A	7	T	PCLKT7_0	PL9A	7	T	PCLKT7_0	PL9A	7	T	PCLKT7_0
9	PL5B	7	C	PCLKC7_0	PL9B	7	C	PCLKC7_0	PL9B	7	C	PCLKC7_0
10	XRES	6			XRES	6			XRES	6		
11	NC	-			NC	-			VCC	-		
12	NC	-			NC	-			GND	-		
13	VCC	-			VCC	-			VCC	-		
14	TCK	6			TCK	6			TCK	6		
15	GND	-			GND	-			GND	-		
16	TDI	6			TDI	6			TDI	6		
17	TMS	6			TMS	6			TMS	6		
18	TDO	6			TDO	6			TDO	6		
19	VCCJ	6			VCCJ	6			VCCJ	6		
20	PL7A	6	T	LLM0_PLLT_IN_A	PL11A	6	T	LLM0_PLLT_IN_A	PL20A	6	T	LLM0_PLLT_IN_A
21	PL7B	6	C	LLM0_PLLC_IN_A	PL11B	6	C	LLM0_PLLC_IN_A	PL20B	6	C	LLM0_PLLC_IN_A
22	PL8A	6	T	LLM0_PLLT_FB_A	PL12A	6	T	LLM0_PLLT_FB_A	PL21A	6	T	LLM0_PLLT_FB_A
23	PL8B	6	C	LLM0_PLLC_FB_A	PL12B	6	C	LLM0_PLLC_FB_A	PL21B	6	C	LLM0_PLLC_FB_A
24	VCCIO6	6			VCCIO6	6			VCCIO6	6		
25	PL9A	6	T		PL13A	6	T		PL22A	6	T	
26	PL9B	6	C		PL13B	6	C		PL22B	6	C	
27	PL10A	6	T		PL14A	6	T		PL23A	6	T	
28	GND6	6			GND6	6			GND6	6		
29	PL10B	6	C		PL14B	6	C		PL23B	6	C	
30	PL11A	6	T	LDQS11	PL15A	6	T	LDQS15	PL24A	6	T	LDQS24
31	PL11B	6	C		PL15B	6	C		PL24B	6	C	
32	PL12A	6	T		PL16A	6	T		PL25A	6	T	
33	PL12B	6	C		PL16B	6	C		PL25B	6	C	
34	PL14A	6	T	VREF1_6	PL18A	6	T	VREF1_6	PL27A	6	T	VREF1_6
35	PL14B	6	C	VREF2_6	PL18B	6	C	VREF2_6	PL27B	6	C	VREF2_6
36	VCCIO6	6			VCCIO6	6			VCCIO6	6		
37*	GND5 GND6	-			GND5 GND6	-			GND5 GND6	-		
38	VCCIO5	5			VCCIO5	5			VCCIO5	5		
39	PB2A	5	T		PB10A	5	T		PB10A	5	T	
40	PB2B	5	C		PB10B	5	C		PB10B	5	C	
41	PB3A	5	T		PB11A	5	T		PB11A	5	T	
42	PB3B	5	C		PB11B	5	C		PB11B	5	C	
43	PB5B	5			PB13B	5			PB13B	5		
44	VCCIO5	5			VCCIO5	5			VCCIO5	5		
45	PB6A	5	T	BDQS6	PB14A	5	T	BDQS14	PB14A	5	T	BDQS14
46	PB6B	5	C		PB14B	5	C		PB14B	5	C	
47	PB7A	5	T		PB15A	5	T		PB15A	5	T	
48	PB7B	5	C		PB15B	5	C		PB15B	5	C	
49	PB8A	5	T	VREF2_5	PB16A	5	T	VREF2_5	PB16A	5	T	VREF2_5

**LFEC1, LFEC3, LFEC6/EC6 Logic Signal Connections: 144 TQFP (Cont.)**

Pin Number	LFEC1				LFEC3				LFEC6/EC6			
	Pin Function	Bank	LVDS	Dual Function	Pin Function	Bank	LVDS	Dual Function	Pin Function	Bank	LVDS	Dual Function
50	PB8B	5	C	VREF1_5	PB16B	5	C	VREF1_5	PB16B	5	C	VREF1_5
51	PB9A	5	T	PCLKT5_0	PB17A	5	T	PCLKT5_0	PB17A	5	T	PCLKT5_0
52	GND5	5			GND5	5			GND5	5		
53	PB9B	5	C	PCLKC5_0	PB17B	5	C	PCLKC5_0	PB17B	5	C	PCLKC5_0
54	VCCAUX	-			VCCAUX	-			VCCAUX	-		
55	VCCIO4	4			VCCIO4	4			VCCIO4	4		
56	PB10A	4	T	WRITEN	PB18A	4	T	WRITEN	PB18A	4	T	WRITEN
57	PB10B	4	C	CS1N	PB18B	4	C	CS1N	PB18B	4	C	CS1N
58	PB11A	4	T	VREF1_4	PB19A	4	T	VREF1_4	PB19A	4	T	VREF1_4
59	PB11B	4	C	CSN	PB19B	4	C	CSN	PB19B	4	C	CSN
60	PB12A	4	T	VREF2_4	PB20A	4	T	VREF2_4	PB20A	4	T	VREF2_4
61	PB12B	4	C	D0/SPID7	PB20B	4	C	D0/SPID7	PB20B	4	C	D0/SPID7
62	PB13A	4	T	D2/SPID5	PB21A	4	T	D2/SPID5	PB21A	4	T	D2/SPID5
63	GND4	4			GND4	4			GND4	4		
64	PB13B	4	C	D1/SPID6	PB21B	4	C	D1/SPID6	PB21B	4	C	D1/SPID6
65	PB14A	4	T	BDQS14	PB22A	4	T	BDQS22	PB22A	4	T	BDQS22
66	PB14B	4	C	D3/SPID4	PB22B	4	C	D3/SPID4	PB22B	4	C	D3/SPID4
67	PB15A	4	T		PB23A	4	T		PB23A	4	T	
68	PB15B	4	C	D4/SPID3	PB23B	4	C	D4/SPID3	PB23B	4	C	D4/SPID3
69	PB16B	4		D5/SPID2	PB24B	4		D5/SPID2	PB24B	4		D5/SPID2
70	PB17B	4		D6/SPID1	PB25B	4		D6/SPID1	PB25B	4		D6/SPID1
71	VCCIO4	4			VCCIO4	4			VCCIO4	4		
72*	GND3 GND4	-			GND3 GND4	-			GND3 GND4	-		
73	VCCIO3	3			VCCIO3	3			VCCIO3	3		
74	PR14A	3		VREF1_3	PR18A	3		VREF1_3	PR27A	3		VREF1_3
75	PR12B	3	C		PR16B	3	C		PR25B	3	C	
76	PR12A	3	T		PR16A	3	T		PR25A	3	T	
77	PR11B	3	C		PR15B	3	C		PR24B	3	C	
78	PR11A	3	T	RDQS11	PR15A	3	T	RDQS15	PR24A	3	T	RDQS24
79	PR10B	3	C	RLM0_PLLC_FB_A	PR14B	3	C	RLM0_PLLC_FB_A	PR23B	3	C	RLM0_PLLC_FB_A
80	GND3	3			GND3	3			GND3	3		
81	PR10A	3	T	RLM0_PLLT_FB_A	PR14A	3	T	RLM0_PLLT_FB_A	PR23A	3	T	RLM0_PLLT_FB_A
82	PR9B	3	C	RLM0_PLLC_IN_A	PR13B	3	C	RLM0_PLLC_IN_A	PR22B	3	C	RLM0_PLLC_IN_A
83	PR9A	3	T	RLM0_PLLT_IN_A	PR13A	3	T	RLM0_PLLT_IN_A	PR22A	3	T	RLM0_PLLT_IN_A
84	VCCIO3	3			VCCIO3	3			VCCIO3	3		
85	PR8B	3	C	DI/CSSPIN	PR12B	3	C	DI/CSSPIN	PR21B	3	C	DI/CSSPIN
86	PR8A	3	T	DOUT/CSON	PR12A	3	T	DOUT/CSON	PR21A	3	T	DOUT/CSON
87	PR7B	3	C	BUSY/SISPI	PR11B	3	C	BUSY/SISPI	PR20B	3	C	BUSY/SISPI
88	PR7A	3	T	D7/SPID0	PR11A	3	T	D7/SPID0	PR20A	3	T	D7/SPID0
89	CFG2	3			CFG2	3			CFG2	3		
90	CFG1	3			CFG1	3			CFG1	3		
91	CFG0	3			CFG0	3			CFG0	3		
92	VCC	-			VCC	-			VCC	-		
93	PROGRAMN	3			PROGRAMN	3			PROGRAMN	3		
94	CCLK	3			CCLK	3			CCLK	3		
95	INITN	3			INITN	3			INITN	3		
96	GND	-			GND	-			GND	-		
97	DONE	3			DONE	3			DONE	3		
98	GND	-			GND	-			GND	-		

**LFEC1, LFEC3, LFEC6/EC6 Logic Signal Connections: 144 TQFP (Cont.)**

Pin Number	LFEC1				LFEC3				LFEC6/EC6			
	Pin Function	Bank	LVDS	Dual Function	Pin Function	Bank	LVDS	Dual Function	Pin Function	Bank	LVDS	Dual Function
99	VCC	-			VCC	-			VCC	-		
100	PR5B	2	C	PCLKC2_0	PR9B	2	C	PCLKC2_0	PR9B	2	C	PCLKC2_0
101	PR5A	2	T	PCLKT2_0	PR9A	2	T	PCLKT2_0	PR9A	2	T	PCLKT2_0
102	PR4B	2	C		PR8B	2	C		PR8B	2	C	
103	PR4A	2	T		PR8A	2	T		PR8A	2	T	
104	PR3B	2	C		PR7B	2	C		PR7B	2	C	
105	PR3A	2	T		PR7A	2	T		PR7A	2	T	
106	PR2B	2	C	VREF1_2	PR2B	2	C	VREF1_2	PR2B	2	C	VREF1_2
107	PR2A	2	T	VREF2_2	PR2A	2	T	VREF2_2	PR2A	2	T	VREF2_2
108	VCCIO2	2			VCCIO2	2			VCCIO2	2		
109*	GND1 GND2	-			GND1 GND2	-			GND1 GND2	-		
110	VCCIO1	1			VCCIO1	1			VCCIO1	1		
111	PT17B	1	C		PT25B	1	C		PT25B	1	C	
112	PT17A	1	T		PT25A	1	T		PT25A	1	T	
113	PT15A	1			PT23A	1			PT23A	1		
114	PT14B	1	C		PT22B	1	C		PT22B	1	C	
115	PT14A	1	T	TDQS14	PT22A	1	T	TDQS22	PT22A	1	T	TDQS22
116	PT13B	1	C		PT21B	1	C		PT21B	1	C	
117	GND1	1			GND1	1			GND1	1		
118	PT13A	1	T		PT21A	1	T		PT21A	1	T	
119	PT12B	1	C		PT20B	1	C		PT20B	1	C	
120	PT12A	1	T		PT20A	1	T		PT20A	1	T	
121	PT11B	1	C	VREF2_1	PT19B	1	C	VREF2_1	PT19B	1	C	VREF2_1
122	PT11A	1	T	VREF1_1	PT19A	1	T	VREF1_1	PT19A	1	T	VREF1_1
123	PT10B	1	C		PT18B	1	C		PT18B	1	C	
124	PT10A	1	T		PT18A	1	T		PT18A	1	T	
125	VCCIO1	1			VCCIO1	1			VCCIO1	1		
126	VCCAUX	-			VCCAUX	-			VCCAUX	-		
127	PT9B	0	C	PCLKC0_0	PT17B	0	C	PCLKC0_0	PT17B	0	C	PCLKC0_0
128	GND0	0			GND0	0			GND0	0		
129	PT9A	0	T	PCLKT0_0	PT17A	0	T	PCLKT0_0	PT17A	0	T	PCLKT0_0
130	PT8B	0	C	VREF1_0	PT16B	0	C	VREF1_0	PT16B	0	C	VREF1_0
131	PT8A	0	T	VREF2_0	PT16A	0	T	VREF2_0	PT16A	0	T	VREF2_0
132	PT7B	0	C		PT15B	0	C		PT15B	0	C	
133	PT7A	0	T		PT15A	0	T		PT15A	0	T	
134	PT6B	0	C		PT14B	0	C		PT14B	0	C	
135	PT6A	0	T	TDQS6	PT14A	0	T	TDQS14	PT14A	0	T	TDQS14
136	VCCIO0	0			VCCIO0	0			VCCIO0	0		
137	PT5B	0	C		PT13B	0	C		PT13B	0	C	
138	PT5A	0	T		PT13A	0	T		PT13A	0	T	
139	PT4B	0	C		PT12B	0	C		PT12B	0	C	
140	PT4A	0	T		PT12A	0	T		PT12A	0	T	
141	PT2B	0	C		PT10B	0	C		PT10B	0	C	
142	PT2A	0	T		PT10A	0	T		PT10A	0	T	
143	VCCIO0	0			VCCIO0	0			VCCIO0	0		
144*	GND0 GND7	-			GND0 GND7	-			GND0 GND7	-		

\*Double bonded to the pin.

**LFEC1, LFEC3 Logic Signal Connections: 208 PQFP**

Pin Number	LFEC1				LFEC3			
	Pin Function	Bank	LVDS	Dual Function	Pin Function	Bank	LVDS	Dual Function
1*	GND0 GND7	-			GND0 GND7	-		
2	VCCIO7	7			VCCIO7	7		
3	PL2A	7	T	VREF2_7	PL2A	7	T	VREF2_7
4	PL2B	7	C	VREF1_7	PL2B	7	C	VREF1_7
5	NC	-			NC	-		
6	NC	-			NC	-		
7	NC	-			PL3B	7		
8	NC	-			PL4A	7	T	
9	NC	-			PL4B	7	C	
10	NC	-			PL5A	7	T	
11	NC	-			PL5B	7	C	
12	NC	-			PL6A	7	T	LDQS6
13	NC	-			VCCIO7	7		
14	NC	-			PL6B	7	C	
15	PL3A	7	T		PL7A	7	T	
16	PL3B	7	C		PL7B	7	C	
17	PL4A	7	T		PL8A	7	T	
18	NC	-			NC	-		
19	PL4B	7	C		PL8B	7	C	
20	PL5A	7	T	PCLKT7_0	PL9A	7	T	PCLKT7_0
21	PL5B	7	C	PCLKC7_0	PL9B	7	C	PCLKC7_0
22	NC	-			VCCAUX	-		
23	XRES	6			XRES	6		
24	NC	-			NC	-		
25	NC	-			NC	-		
26	VCC	-			VCC	-		
27	TCK	6			TCK	6		
28	GND	-			GND	-		
29	TDI	6			TDI	6		
30	TMS	6			TMS	6		
31	TDO	6			TDO	6		
32	VCCJ	6			VCCJ	6		
33	PL7A	6	T	LLM0_PLLT_IN_A	PL11A	6	T	LLM0_PLLT_IN_A
34	PL7B	6	C	LLM0_PLLC_IN_A	PL11B	6	C	LLM0_PLLC_IN_A
35	PL8A	6	T	LLM0_PLLT_FB_A	PL12A	6	T	LLM0_PLLT_FB_A
36	PL8B	6	C	LLM0_PLLC_FB_A	PL12B	6	C	LLM0_PLLC_FB_A
37	VCCIO6	6			VCCIO6	6		
38	PL9A	6	T		PL13A	6	T	
39	PL9B	6	C		PL13B	6	C	
40	PL10A	6	T		PL14A	6	T	
41	GND6	6			GND6	6		
42	PL10B	6	C		PL14B	6	C	



**LFEC1, LFEC3 Logic Signal Connections: 208 PQFP (Cont.)**

Pin Number	LFEC1				LFEC3			
	Pin Function	Bank	LVDS	Dual Function	Pin Function	Bank	LVDS	Dual Function
43	PL11A	6	T	LDQS11	PL15A	6	T	LDQS15
44	PL11B	6	C		PL15B	6	C	
45	PL12A	6	T		PL16A	6	T	
46	PL12B	6	C		PL16B	6	C	
47	PL13A	6	T		PL17A	6	T	
48	PL13B	6	C		PL17B	6	C	
49	PL14A	6	T	VREF1_6	PL18A	6	T	VREF1_6
50	PL14B	6	C	VREF2_6	PL18B	6	C	VREF2_6
51	VCCIO6	6			VCCIO6	6		
52*	GND5 GND6	-			GND5 GND6	-		
53	VCCIO5	5			VCCIO5	5		
54	NC	-			PB2A	5	T	
55	NC	-			PB2B	5	C	
56	NC	-			PB3A	5	T	
57	NC	-			PB3B	5	C	
58	NC	-			PB4A	5	T	
59	NC	-			PB4B	5	C	
60	NC	-			PB5A	5	T	
61	NC	-			PB5B	5	C	
62	NC	-			PB6A	5	T	BDQS6
63	NC	-			PB6B	5	C	
64	NC	-			VCCIO5	5		
65	PB2A	5	T		PB10A	5	T	
66	PB2B	5	C		PB10B	5	C	
67	PB3A	5	T		PB11A	5	T	
68	PB3B	5	C		PB11B	5	C	
69	PB4A	5	T		PB12A	5	T	
70	PB4B	5	C		PB12B	5	C	
71	PB5A	5	T		PB13A	5	T	
72	NC	-			GND5	5		
73	PB5B	5	C		PB13B	5	C	
74	VCCIO5	5			VCCIO5	5		
75	PB6A	5	T	BDQS6	PB14A	5	T	BDQS14
76	PB6B	5	C		PB14B	5	C	
77	PB7A	5	T		PB15A	5	T	
78	PB7B	5	C		PB15B	5	C	
79	PB8A	5	T	VREF2_5	PB16A	5	T	VREF2_5
80	PB8B	5	C	VREF1_5	PB16B	5	C	VREF1_5
81	PB9A	5	T	PCLKT5_0	PB17A	5	T	PCLKT5_0
82	GND5	5			GND5	5		
83	PB9B	5	C	PCLKC5_0	PB17B	5	C	PCLKC5_0
84	VCCAUX	-			VCCAUX	-		

**LFEC1, LFEC3 Logic Signal Connections: 208 PQFP (Cont.)**

Pin Number	LFEC1				LFEC3			
	Pin Function	Bank	LVDS	Dual Function	Pin Function	Bank	LVDS	Dual Function
85	VCCIO4	4			VCCIO4	4		
86	PB10A	4	T	WRITEN	PB18A	4	T	WRITEN
87	PB10B	4	C	CS1N	PB18B	4	C	CS1N
88	PB11A	4	T	VREF1_4	PB19A	4	T	VREF1_4
89	PB11B	4	C	CSN	PB19B	4	C	CSN
90	PB12A	4	T	VREF2_4	PB20A	4	T	VREF2_4
91	PB12B	4	C	D0/SPID7	PB20B	4	C	D0/SPID7
92	PB13A	4	T	D2/SPID5	PB21A	4	T	D2/SPID5
93	GND4	4			GND4	4		
94	PB13B	4	C	D1/SPID6	PB21B	4	C	D1/SPID6
95	PB14A	4	T	BDQS14	PB22A	4	T	BDQS22
96	PB14B	4	C	D3/SPID4	PB22B	4	C	D3/SPID4
97	PB15A	4	T		PB23A	4	T	
98	PB15B	4	C	D4/SPID3	PB23B	4	C	D4/SPID3
99	PB16A	4	T		PB24A	4	T	
100	PB16B	4	C	D5/SPID2	PB24B	4	C	D5/SPID2
101	PB17A	4	T		PB25A	4	T	
102	PB17B	4	C	D6/SPID1	PB25B	4	C	D6/SPID1
103	NC	-			NC	-		
104	VCCIO4	4			VCCIO4	4		
105*	GND3 GND4	-			GND3 GND4	-		
106	VCCIO3	3			VCCIO3	3		
107	PR14B	3	C	VREF2_3	PR18B	3	C	VREF2_3
108	PR14A	3	T	VREF1_3	PR18A	3	T	VREF1_3
109	PR13B	3	C		PR17B	3	C	
110	PR13A	3	T		PR17A	3	T	
111	PR12B	3	C		PR16B	3	C	
112	PR12A	3	T		PR16A	3	T	
113	PR11B	3	C		PR15B	3	C	
114	PR11A	3	T	RDQS11	PR15A	3	T	RDQS15
115	PR10B	3	C	RLM0_PLLC_FB_A	PR14B	3	C	RLM0_PLLC_FB_A
116	GND3	3			GND3	3		
117	PR10A	3	T	RLM0_PLLT_FB_A	PR14A	3	T	RLM0_PLLT_FB_A
118	PR9B	3	C	RLM0_PLLC_IN_A	PR13B	3	C	RLM0_PLLC_IN_A
119	PR9A	3	T	RLM0_PLLT_IN_A	PR13A	3	T	RLM0_PLLT_IN_A
120	VCCIO3	3			VCCIO3	3		
121	PR8B	3	C	DI/CSSPIN	PR12B	3	C	DI/CSSPIN
122	PR8A	3	T	DOUT/CSON	PR12A	3	T	DOUT/CSON
123	PR7B	3	C	BUSY/SISPI	PR11B	3	C	BUSY/SISPI
124	PR7A	3	T	D7/SPID0	PR11A	3	T	D7/SPID0
125	CFG2	3			CFG2	3		
126	CFG1	3			CFG1	3		

**LFEC1, LFEC3 Logic Signal Connections: 208 PQFP (Cont.)**

Pin Number	LFEC1				LFEC3			
	Pin Function	Bank	LVDS	Dual Function	Pin Function	Bank	LVDS	Dual Function
127	CFG0	3			CFG0	3		
128	VCC	-			VCC	-		
129	PROGRAMN	3			PROGRAMN	3		
130	CCLK	3			CCLK	3		
131	INITN	3			INITN	3		
132	GND	-			GND	-		
133	DONE	3			DONE	3		
134	GND	-			GND	-		
135	VCC	-			VCC	-		
136	NC	-			VCCAUX	-		
137	PR5B	2	C	PCLKC2_0	PR9B	2	C	PCLKC2_0
138	NC	-			GND2	2		
139	PR5A	2	T	PCLKT2_0	PR9A	2	T	PCLKT2_0
140	PR4B	2	C		PR8B	2	C	
141	PR4A	2	T		PR8A	2	T	
142	PR3B	2	C		PR7B	2	C	
143	PR3A	2	T		PR7A	2	T	
144	NC	-			PR6B	2	C	
145	NC	-			VCCIO2	2		
146	NC	-			PR6A	2	T	RDQS6
147	NC	-			PR5B	2	C	
148	NC	-			PR5A	2	T	
149	NC	-			PR4B	2	C	
150	NC	-			PR4A	2	T	
151	NC	-			NC	-		
152	NC	-			NC	-		
153	PR2B	2	C	VREF1_2	PR2B	2	C	VREF1_2
154	PR2A	2	T	VREF2_2	PR2A	2	T	VREF2_2
155	VCCIO2	2			VCCIO2	2		
156*	GND1 GND2	-			GND1 GND2	-		
157	VCCIO1	1			VCCIO1	1		
158	NC	-			NC	-		
159	PT17B	1	C		PT25B	1	C	
160	PT17A	1	T		PT25A	1	T	
161	PT16B	1	C		PT24B	1	C	
162	PT16A	1	T		PT24A	1	T	
163	PT15B	1	C		PT23B	1	C	
164	PT15A	1	T		PT23A	1	T	
165	PT14B	1	C		PT22B	1	C	
166	PT14A	1	T	TDQS14	PT22A	1	T	TDQS22
167	PT13B	1	C		PT21B	1	C	
168	GND1	1			GND1	1		

**LFEC1, LFEC3 Logic Signal Connections: 208 PQFP (Cont.)**

Pin Number	LFEC1				LFEC3			
	Pin Function	Bank	LVDS	Dual Function	Pin Function	Bank	LVDS	Dual Function
169	PT13A	1	T		PT21A	1	T	
170	PT12B	1	C		PT20B	1	C	
171	PT12A	1	T		PT20A	1	T	
172	PT11B	1	C	VREF2_1	PT19B	1	C	VREF2_1
173	PT11A	1	T	VREF1_1	PT19A	1	T	VREF1_1
174	PT10B	1	C		PT18B	1	C	
175	PT10A	1	T		PT18A	1	T	
176	VCCIO1	1			VCCIO1	1		
177	VCCAUX	-			VCCAUX	-		
178	PT9B	0	C	PCLKC0_0	PT17B	0	C	PCLKC0_0
179	GND0	0			GND0	0		
180	PT9A	0	T	PCLKT0_0	PT17A	0	T	PCLKT0_0
181	PT8B	0	C	VREF1_0	PT16B	0	C	VREF1_0
182	PT8A	0	T	VREF2_0	PT16A	0	T	VREF2_0
183	PT7B	0	C		PT15B	0	C	
184	PT7A	0	T		PT15A	0	T	
185	PT6B	0	C		PT14B	0	C	
186	PT6A	0	T	TDQS6	PT14A	0	T	TDQS14
187	VCCIO0	0			VCCIO0	0		
188	PT5B	0	C		PT13B	0	C	
189	NC	-			GND0	0		
190	PT5A	0	T		PT13A	0	T	
191	PT4B	0	C		PT12B	0	C	
192	PT4A	0	T		PT12A	0	T	
193	PT3B	0	C		PT11B	0	C	
194	PT3A	0	T		PT11A	0	T	
195	PT2B	0	C		PT10B	0	C	
196	PT2A	0	T		PT10A	0	T	
197	NC	-			VCCIO0	0		
198	NC	-			PT6B	0	C	
199	NC	-			PT6A	0	T	TDQS6
200	NC	-			PT5B	0	C	
201	NC	-			PT5A	0	T	
202	NC	-			PT4B	0	C	
203	NC	-			PT4A	0	T	
204	NC	-			PT3B	0	C	
205	NC	-			PT3A	0	T	
206	NC	-			PT2B	0	C	
207	NC	-			PT2A	0	T	
208	VCCIO0	0			VCCIO0	0		

\* Double bonded to the pin.

**LFCEP/EC6, LFCEP/EC10 Logic Signal Connections: 208 PQFP**

Pin Number	LFCEP6/LFCEC6				LFCEP10/LFCEC10			
	Pin Function	Bank	LVDS	Dual Function	Pin Function	Bank	LVDS	Dual Function
1*	GND0 GND7	-			GND0 GND7	-		
2	VCCIO7	7			VCCIO7	7		
3	PL2A	7	T	VREF2_7	PL2A	7	T	VREF2_7
4	PL2B	7	C	VREF1_7	PL2B	7	C	VREF1_7
5	NC	-			VCC	-		
6	NC	-			GND	-		
7	PL3B	7			PL12B	7		
8	PL4A	7	T		PL13A	7	T	
9	PL4B	7	C		PL13B	7	C	
10	PL5A	7	T		PL14A	7	T	
11	PL5B	7	C		PL14B	7	C	
12	PL6A	7	T	LDQS6	PL15A	7	T	LDQS15
13	VCCIO7	7			VCCIO7	7		
14	PL6B	7	C		PL15B	7	C	
15	PL7A	7	T		PL16A	7	T	
16	PL7B	7	C		PL16B	7	C	
17	PL8A	7	T		PL17A	7	T	
18	GND7	7			GND7	7		
19	PL8B	7	C		PL17B	7	C	
20	PL9A	7	T	PCLKT7_0	PL18A	7	T	PCLKT7_0
21	PL9B	7	C	PCLKC7_0	PL18B	7	C	PCLKC7_0
22	VCCAUX	-			VCCAUX	-		
23	XRES	6			XRES	6		
24	VCC	-			VCC	-		
25	GND	-			GND	-		
26	VCC	-			VCC	-		
27	TCK	6			TCK	6		
28	GND	-			GND	-		
29	TDI	6			TDI	6		
30	TMS	6			TMS	6		
31	TDO	6			TDO	6		
32	VCCJ	6			VCCJ	6		
33	PL20A	6	T	LLM0_PLLT_IN_A	PL29A	6	T	LLM0_PLLT_IN_A
34	PL20B	6	C	LLM0_PLLC_IN_A	PL29B	6	C	LLM0_PLLC_IN_A
35	PL21A	6	T	LLM0_PLLT_FB_A	PL30A	6	T	LLM0_PLLT_FB_A
36	PL21B	6	C	LLM0_PLLC_FB_A	PL30B	6	C	LLM0_PLLC_FB_A
37	VCCIO6	6			VCCIO6	6		
38	PL22A	6	T		PL31A	6	T	
39	PL22B	6	C		PL31B	6	C	
40	PL23A	6	T		PL32A	6	T	
41	GND6	6			GND6	6		
42	PL23B	6	C		PL32B	6	C	

**LFECP/EC6, LFECP/EC10 Logic Signal Connections: 208 PQFP (Cont.)**

Pin Number	LFECP6/LFEC6				LFECP10/LFEC10			
	Pin Function	Bank	LVDS	Dual Function	Pin Function	Bank	LVDS	Dual Function
43	PL24A	6	T	LDQS24	PL33A	6	T	LDQS33
44	PL24B	6	C		PL33B	6	C	
45	PL25A	6	T		PL34A	6	T	
46	PL25B	6	C		PL34B	6	C	
47	PL26A	6	T		PL35A	6	T	
48	PL26B	6	C		PL35B	6	C	
49	PL27A	6	T	VREF1_6	PL36A	6	T	VREF1_6
50	PL27B	6	C	VREF2_6	PL36B	6	C	VREF2_6
51	VCCIO6	6			VCCIO6	6		
52*	GND5 GND6	-			GND5 GND6	-		
53	VCCIO5	5			VCCIO5	5		
54	PB2A	5	T		PB2A	5	T	
55	PB2B	5	C		PB2B	5	C	
56	PB3A	5	T		PB3A	5	T	
57	PB3B	5	C		PB3B	5	C	
58	PB4A	5	T		PB4A	5	T	
59	PB4B	5	C		PB4B	5	C	
60	PB5A	5	T		PB5A	5	T	
61	PB5B	5	C		PB5B	5	C	
62	PB6A	5	T	BDQS6	PB6A	5	T	BDQS6
63	PB6B	5	C		PB6B	5	C	
64	VCCIO5	5			VCCIO5	5		
65	PB10A	5	T		PB18A	5	T	
66	PB10B	5	C		PB18B	5	C	
67	PB11A	5	T		PB19A	5	T	
68	PB11B	5	C		PB19B	5	C	
69	PB12A	5	T		PB20A	5	T	
70	PB12B	5	C		PB20B	5	C	
71	PB13A	5	T		PB21A	5	T	
72	GND5	5			GND5	5		
73	PB13B	5	C		PB21B	5	C	
74	VCCIO5	5			VCCIO5	5		
75	PB14A	5	T	BDQS14	PB22A	5	T	BDQS22
76	PB14B	5	C		PB22B	5	C	
77	PB15A	5	T		PB23A	5	T	
78	PB15B	5	C		PB23B	5	C	
79	PB16A	5	T	VREF2_5	PB24A	5	T	VREF2_5
80	PB16B	5	C	VREF1_5	PB24B	5	C	VREF1_5
81	PB17A	5	T	PCLKT5_0	PB25A	5	T	PCLKT5_0
82	GND5	5			GND5	5		
83	PB17B	5	C	PCLKC5_0	PB25B	5	C	PCLKC5_0
84	VCCAUX	-			VCCAUX	-		

**LFECP/EC6, LFECP/EC10 Logic Signal Connections: 208 PQFP (Cont.)**

Pin Number	LFECP6/LFEC6				LFECP10/LFEC10			
	Pin Function	Bank	LVDS	Dual Function	Pin Function	Bank	LVDS	Dual Function
85	VCCIO4	4			VCCIO4	4		
86	PB18A	4	T	WRITEN	PB26A	4	T	WRITEN
87	PB18B	4	C	CS1N	PB26B	4	C	CS1N
88	PB19A	4	T	VREF1_4	PB27A	4	T	VREF1_4
89	PB19B	4	C	CSN	PB27B	4	C	CSN
90	PB20A	4	T	VREF2_4	PB28A	4	T	VREF2_4
91	PB20B	4	C	D0/SPID7	PB28B	4	C	D0/SPID7
92	PB21A	4	T	D2/SPID5	PB29A	4	T	D2/SPID5
93	GND4	4			GND4	4		
94	PB21B	4	C	D1/SPID6	PB29B	4	C	D1/SPID6
95	PB22A	4	T	BDQS22	PB30A	4	T	BDQS30
96	PB22B	4	C	D3/SPID4	PB30B	4	C	D3/SPID4
97	PB23A	4	T		PB31A	4	T	
98	PB23B	4	C	D4/SPID3	PB31B	4	C	D4/SPID3
99	PB24A	4	T		PB32A	4	T	
100	PB24B	4	C	D5/SPID2	PB32B	4	C	D5/SPID2
101	PB25A	4	T		PB33A	4	T	
102	PB25B	4	C	D6/SPID1	PB33B	4	C	D6/SPID1
103	PB33A	4			PB41A	4		
104	VCCIO4	4			VCCIO4	4		
105*	GND3 GND4	-			GND3 GND4	-		
106	VCCIO3	3			VCCIO3	3		
107	PR27B	3	C	VREF2_3	PR36B	3	C	VREF2_3
108	PR27A	3	T	VREF1_3	PR36A	3	T	VREF1_3
109	PR26B	3	C		PR35B	3	C	
110	PR26A	3	T		PR35A	3	T	
111	PR25B	3	C		PR34B	3	C	
112	PR25A	3	T		PR34A	3	T	
113	PR24B	3	C		PR33B	3	C	
114	PR24A	3	T	RDQS24	PR33A	3	T	RDQS33
115	PR23B	3	C	RLM0_PLLC_FB_A	PR32B	3	C	RLM0_PLLC_FB_A
116	GND3	3			GND3	3		
117	PR23A	3	T	RLM0_PLLT_FB_A	PR32A	3	T	RLM0_PLLT_FB_A
118	PR22B	3	C	RLM0_PLLC_IN_A	PR31B	3	C	RLM0_PLLC_IN_A
119	PR22A	3	T	RLM0_PLLT_IN_A	PR31A	3	T	RLM0_PLLT_IN_A
120	VCCIO3	3			VCCIO3	3		
121	PR21B	3	C	DI/CSSPIN	PR30B	3	C	DI/CSSPIN
122	PR21A	3	T	DOUT/CSON	PR30A	3	T	DOUT/CSON
123	PR20B	3	C	BUSY/SISPI	PR29B	3	C	BUSY/SISPI
124	PR20A	3	T	D7/SPID0	PR29A	3	T	D7/SPID0
125	CFG2	3			CFG2	3		
126	CFG1	3			CFG1	3		

**LFCEP/EC6, LFCEP/EC10 Logic Signal Connections: 208 PQFP (Cont.)**

Pin Number	LFCEP6/LFCEC6				LFCEP10/LFCEC10			
	Pin Function	Bank	LVDS	Dual Function	Pin Function	Bank	LVDS	Dual Function
127	CFG0	3			CFG0	3		
128	VCC	-			VCC	-		
129	PROGRAMN	3			PROGRAMN	3		
130	CCLK	3			CCLK	3		
131	INITN	3			INITN	3		
132	GND	-			GND	-		
133	DONE	3			DONE	3		
134	GND	-			GND	-		
135	VCC	-			VCC	-		
136	VCCAUX	-			VCCAUX	-		
137	PR9B	2	C	PCLKC2_0	PR18B	2	C	PCLKC2_0
138	GND2	2			GND2	2		
139	PR9A	2	T	PCLKT2_0	PR18A	2	T	PCLKT2_0
140	PR8B	2	C		PR17B	2	C	
141	PR8A	2	T		PR17A	2	T	
142	PR7B	2	C		PR16B	2	C	
143	PR7A	2	T		PR16A	2	T	
144	PR6B	2	C		PR15B	2	C	
145	VCCIO2	2			VCCIO2	2		
146	PR6A	2	T	RDQS6	PR15A	2	T	RDQS15
147	PR5B	2	C		PR14B	2	C	
148	PR5A	2	T		PR14A	2	T	
149	PR4B	2	C		PR13B	2	C	
150	PR4A	2	T		PR13A	2	T	
151	NC	-			GND	-		
152	NC	-			VCC	-		
153	PR2B	2	C	VREF1_2	PR2B	2	C	VREF1_2
154	PR2A	2	T	VREF2_2	PR2A	2	T	VREF2_2
155	VCCIO2	2			VCCIO2	2		
156*	GND1 GND2	-			GND1 GND2	-		
157	VCCIO1	1			VCCIO1	1		
158	PT33A	1			PT41A	1		
159	PT25B	1	C		PT33B	1	C	
160	PT25A	1	T		PT33A	1	T	
161	PT24B	1	C		PT32B	1	C	
162	PT24A	1	T		PT32A	1	T	
163	PT23B	1	C		PT31B	1	C	
164	PT23A	1	T		PT31A	1	T	
165	PT22B	1	C		PT30B	1	C	
166	PT22A	1	T	TDQS22	PT30A	1	T	TDQS30
167	PT21B	1	C		PT29B	1	C	
168	GND1	1			GND1	1		



**LFEC6/EC6, LFEC6/EC10 Logic Signal Connections: 208 PQFP (Cont.)**

Pin Number	LFEC6/LFEC6				LFEC10/LFEC10			
	Pin Function	Bank	LVDS	Dual Function	Pin Function	Bank	LVDS	Dual Function
169	PT21A	1	T		PT29A	1	T	
170	PT20B	1	C		PT28B	1	C	
171	PT20A	1	T		PT28A	1	T	
172	PT19B	1	C	VREF2_1	PT27B	1	C	VREF2_1
173	PT19A	1	T	VREF1_1	PT27A	1	T	VREF1_1
174	PT18B	1	C		PT26B	1	C	
175	PT18A	1	T		PT26A	1	T	
176	VCCIO1	1			VCCIO1	1		
177	VCCAUX	-			VCCAUX	-		
178	PT17B	0	C	PCLKC0_0	PT25B	0	C	PCLKC0_0
179	GND0	0			GND0	0		
180	PT17A	0	T	PCLKT0_0	PT25A	0	T	PCLKT0_0
181	PT16B	0	C	VREF1_0	PT24B	0	C	VREF1_0
182	PT16A	0	T	VREF2_0	PT24A	0	T	VREF2_0
183	PT15B	0	C		PT23B	0	C	
184	PT15A	0	T		PT23A	0	T	
185	PT14B	0	C		PT22B	0	C	
186	PT14A	0	T	TDQS14	PT22A	0	T	TDQS22
187	VCCIO0	0			VCCIO0	0		
188	PT13B	0	C		PT21B	0	C	
189	GND0	0			GND0	0		
190	PT13A	0	T		PT21A	0	T	
191	PT12B	0	C		PT20B	0	C	
192	PT12A	0	T		PT20A	0	T	
193	PT11B	0	C		PT19B	0	C	
194	PT11A	0	T		PT19A	0	T	
195	PT10B	0	C		PT18B	0	C	
196	PT10A	0	T		PT18A	0	T	
197	VCCIO0	0			VCCIO0	0		
198	PT6B	0	C		PT6B	0	C	
199	PT6A	0	T	TDQS6	PT6A	0	T	TDQS6
200	PT5B	0	C		PT5B	0	C	
201	PT5A	0	T		PT5A	0	T	
202	PT4B	0	C		PT4B	0	C	
203	PT4A	0	T		PT4A	0	T	
204	PT3B	0	C		PT3B	0	C	
205	PT3A	0	T		PT3A	0	T	
206	PT2B	0	C		PT2B	0	C	
207	PT2A	0	T		PT2A	0	T	
208	VCCIO0	0			VCCIO0	0		

\*Double bonded to the pin.

**LFEC3 and LFECP/EC6 Logic Signal Connections: 256 fpBGA**

Ball Number	LFEC3				LFECP6/LFEC6			
	Ball Function	Bank	LVDS	Dual Function	Ball Function	Bank	LVDS	Dual Function
GND	GND7	7			GND7	7		
D4	PL2A	7	T	VREF2_7	PL2A	7	T	VREF2_7
D3	PL2B	7	C	VREF1_7	PL2B	7	C	VREF1_7
C3	PL3A	7	T		PL3A	7	T	
C2	PL3B	7	C		PL3B	7	C	
B1	PL4A	7	T		PL4A	7	T	
C1	PL4B	7	C		PL4B	7	C	
E3	PL5A	7	T		PL5A	7	T	
E4	PL5B	7	C		PL5B	7	C	
F4	PL6A	7	T	LDQS6	PL6A	7	T	LDQS6
F5	PL6B	7	C		PL6B	7	C	
G4	PL7A	7	T		PL7A	7	T	
G3	PL7B	7	C		PL7B	7	C	
D2	PL8A	7	T		PL8A	7	T	
D1	PL8B	7	C		PL8B	7	C	
E1	PL9A	7	T	PCLKT7_0	PL9A	7	T	PCLKT7_0
GND	GND7	7			GND7	7		
E2	PL9B	7	C	PCLKC7_0	PL9B	7	C	PCLKC7_0
F3	XRES	6			XRES	6		
G5	NC	-			PL11A	6	T	
H5	NC	-			PL11B	6	C	
F2	NC	-			PL12A	6	T	
F1	NC	-			PL12B	6	C	
H4	NC	-			PL13A	6	T	
H3	NC	-			PL13B	6	C	
G2	NC	-			PL14A	6	T	
-	-	-			GND6	6		
G1	NC	-			PL14B	6	C	
J4	NC	-			PL15A	6	T	LDQS15
J3	NC	-			PL15B	6	C	
J5	NC	-			PL16A	6	T	
K5	NC	-			PL16B	6	C	
H2	NC	-			PL17A	6	T	
H1	NC	-			PL17B	6	C	
J2	NC	-			PL18A	6	T	
-	-	-			GND6	6		
J1	NC	-			PL18B	6	C	
K4	TCK	6			TCK	6		
K3	TDI	6			TDI	6		
L3	TMS	6			TMS	6		
L5	TDO	6			TDO	6		
L4	VCCJ	6			VCCJ	6		

**LFEC3 and LFEC6/EC6 Logic Signal Connections: 256 fpBGA (Cont.)**

Ball Number	LFEC3				LFEC6/EC6			
	Ball Function	Bank	LVDS	Dual Function	Ball Function	Bank	LVDS	Dual Function
K2	PL11A	6	T	LLM0_PLLT_IN_A	PL20A	6	T	LLM0_PLLT_IN_A
K1	PL11B	6	C	LLM0_PLLC_IN_A	PL20B	6	C	LLM0_PLLC_IN_A
L2	PL12A	6	T	LLM0_PLLT_FB_A	PL21A	6	T	LLM0_PLLT_FB_A
L1	PL12B	6	C	LLM0_PLLC_FB_A	PL21B	6	C	LLM0_PLLC_FB_A
M2	PL13A	6	T		PL22A	6	T	
M1	PL13B	6	C		PL22B	6	C	
N1	PL14A	6	T		PL23A	6	T	
GND	GND6	6			GND6	6		
N2	PL14B	6	C		PL23B	6	C	
M4	PL15A	6	T	LDQS15	PL24A	6	T	LDQS24
M3	PL15B	6	C		PL24B	6	C	
P1	PL16A	6	T		PL25A	6	T	
R1	PL16B	6	C		PL25B	6	C	
P2	PL17A	6	T		PL26A	6	T	
P3	PL17B	6	C		PL26B	6	C	
N3	PL18A	6	T	VREF1_6	PL27A	6	T	VREF1_6
N4	PL18B	6	C	VREF2_6	PL27B	6	C	VREF2_6
GND	GND6	6			GND6	6		
GND	GND5	5			GND5	5		
P4	PB2A	5	T		PB2A	5	T	
N5	PB2B	5	C		PB2B	5	C	
P5	PB3A	5	T		PB3A	5	T	
P6	PB3B	5	C		PB3B	5	C	
R4	PB4A	5	T		PB4A	5	T	
R3	PB4B	5	C		PB4B	5	C	
T2	PB5A	5	T		PB5A	5	T	
T3	PB5B	5	C		PB5B	5	C	
R5	PB6A	5	T	BDQS6	PB6A	5	T	BDQS6
R6	PB6B	5	C		PB6B	5	C	
T4	PB7A	5	T		PB7A	5	T	
T5	PB7B	5	C		PB7B	5	C	
N6	PB8A	5	T		PB8A	5	T	
M6	PB8B	5	C		PB8B	5	C	
T6	PB9A	5	T		PB9A	5	T	
GND	GND5	5			GND5	5		
T7	PB9B	5	C		PB9B	5	C	
P7	PB10A	5	T		PB10A	5	T	
N7	PB10B	5	C		PB10B	5	C	
R7	PB11A	5	T		PB11A	5	T	
R8	PB11B	5	C		PB11B	5	C	
M7	PB12A	5	T		PB12A	5	T	
M8	PB12B	5	C		PB12B	5	C	
T8	PB13A	5	T		PB13A	5	T	

**LFEC3 and LFECP/EC6 Logic Signal Connections: 256 fpBGA (Cont.)**

Ball Number	LFEC3				LFECP6/LFEC6			
	Ball Function	Bank	LVDS	Dual Function	Ball Function	Bank	LVDS	Dual Function
GND	GND5	5			GND5	5		
T9	PB13B	5	C		PB13B	5	C	
P8	PB14A	5	T	BDQS14	PB14A	5	T	BDQS14
N8	PB14B	5	C		PB14B	5	C	
R9	PB15A	5	T		PB15A	5	T	
R10	PB15B	5	C		PB15B	5	C	
P9	PB16A	5	T	VREF2_5	PB16A	5	T	VREF2_5
N9	PB16B	5	C	VREF1_5	PB16B	5	C	VREF1_5
T10	PB17A	5	T	PCLKT5_0	PB17A	5	T	PCLKT5_0
GND	GND5	5			GND5	5		
T11	PB17B	5	C	PCLKC5_0	PB17B	5	C	PCLKC5_0
T12	PB18A	4	T	WRITEN	PB18A	4	T	WRITEN
T13	PB18B	4	C	CS1N	PB18B	4	C	CS1N
P10	PB19A	4	T	VREF1_4	PB19A	4	T	VREF1_4
N10	PB19B	4	C	CSN	PB19B	4	C	CSN
T14	PB20A	4	T	VREF2_4	PB20A	4	T	VREF2_4
T15	PB20B	4	C	D0/SPID7	PB20B	4	C	D0/SPID7
M10	PB21A	4	T	D2/SPID5	PB21A	4	T	D2/SPID5
GND	GND4	4			GND4	4		
M11	PB21B	4	C	D1/SPID6	PB21B	4	C	D1/SPID6
R11	PB22A	4	T	BDQS22	PB22A	4	T	BDQS22
P11	PB22B	4	C	D3/SPID4	PB22B	4	C	D3/SPID4
R13	PB23A	4	T		PB23A	4	T	
R14	PB23B	4	C	D4/SPID3	PB23B	4	C	D4/SPID3
P12	PB24A	4	T		PB24A	4	T	
P13	PB24B	4	C	D5/SPID2	PB24B	4	C	D5/SPID2
N11	PB25A	4	T		PB25A	4	T	
-	-	-			GND4	4		
N12	PB25B	4	C	D6/SPID1	PB25B	4	C	D6/SPID1
R12	NC	-			PB26A	4		
GND	GND4	4			GND4	4		
-	-	-			GND4	4		
GND	GND3	3			GND3	3		
N13	PR18B	3	C	VREF2_3	PR27B	3	C	VREF2_3
N14	PR18A	3	T	VREF1_3	PR27A	3	T	VREF1_3
P14	PR17B	3	C		PR26B	3	C	
P15	PR17A	3	T		PR26A	3	T	
R15	PR16B	3	C		PR25B	3	C	
R16	PR16A	3	T		PR25A	3	T	
M13	PR15B	3	C		PR24B	3	C	
M14	PR15A	3	T	RDQS15	PR24A	3	T	RDQS24
P16	PR14B	3	C	RLM0_PLLC_FB_A	PR23B	3	C	RLM0_PLLC_FB_A
GND	GND3	3			GND3	3		

**LFEC3 and LFECP/EC6 Logic Signal Connections: 256 fpBGA (Cont.)**

Ball Number	LFEC3				LFECP6/LFEC6			
	Ball Function	Bank	LVDS	Dual Function	Ball Function	Bank	LVDS	Dual Function
N16	PR14A	3	T	RLM0_PLLT_FB_A	PR23A	3	T	RLM0_PLLT_FB_A
N15	PR13B	3	C	RLM0_PLLC_IN_A	PR22B	3	C	RLM0_PLLC_IN_A
M15	PR13A	3	T	RLM0_PLLT_IN_A	PR22A	3	T	RLM0_PLLT_IN_A
M16	PR12B	3	C	DI/CSSPIN	PR21B	3	C	DI/CSSPIN
L16	PR12A	3	T	DOUT/CSON	PR21A	3	T	DOUT/CSON
K16	PR11B	3	C	BUSY/SISPI	PR20B	3	C	BUSY/SISPI
J16	PR11A	3	T	D7/SPID0	PR20A	3	T	D7/SPID0
L12	CFG2	3			CFG2	3		
L14	CFG1	3			CFG1	3		
L13	CFG0	3			CFG0	3		
K13	PROGRAMN	3			PROGRAMN	3		
L15	CCLK	3			CCLK	3		
K15	INITN	3			INITN	3		
K14	DONE	3			DONE	3		
	-	-			GND3	3		
H16	NC	-			PR18B	3	C	
H15	NC	-			PR18A	3	T	
G16	NC	-			PR17B	3	C	
G15	NC	-			PR17A	3	T	
K12	NC	-			PR16B	3	C	
J12	NC	-			PR16A	3	T	
J14	NC	-			PR15B	3	C	
J15	NC	-			PR15A	3	T	RDQS15
F16	NC	-			PR14B	3	C	
-	-	-			GND3	3		
F15	NC	-			PR14A	3	T	
J13	NC	-			PR13B	3	C	
H13	NC	-			PR13A	3	T	
H14	NC	-			PR12B	3	C	
G14	NC	-			PR12A	3	T	
E16	NC	-			PR11B	3	C	
E15	NC	-			PR11A	3	T	
H12	PR9B	2	C	PCLKC2_0	PR9B	2	C	PCLKC2_0
GND	GND2	2			GND2			
G12	PR9A	2	T	PCLKT2_0	PR9A	2	T	PCLKT2_0
G13	PR8B	2	C		PR8B	2	C	
F13	PR8A	2	T		PR8A	2	T	
F12	PR7B	2	C		PR7B	2	C	
E13	PR7A	2	T		PR7A	2	T	
D16	PR6B	2	C		PR6B	2	C	
D15	PR6A	2	T	RDQS6	PR6A	2	T	RDQS6
F14	PR5B	2	C		PR5B	2	C	
E14	PR5A	2	T		PR5A	2	T	

**LFEC3 and LFEC6/EC6 Logic Signal Connections: 256 fpBGA (Cont.)**

Ball Number	LFEC3				LFEC6/EC6			
	Ball Function	Bank	LVDS	Dual Function	Ball Function	Bank	LVDS	Dual Function
C16	PR4B	2	C		PR4B	2	C	
B16	PR4A	2	T		PR4A	2	T	
C15	PR3B	2	C		PR3B	2	C	
C14	PR3A	2	T		PR3A	2	T	
D14	PR2B	2	C	VREF1_2	PR2B	2	C	VREF1_2
D13	PR2A	2	T	VREF2_2	PR2A	2	T	VREF2_2
GND	GND2	2			GND2	2		
GND	GND1	1			GND1	1		
-	-	-			GND1	1		
B13	NC	-			PT26B	1	C	
C13	NC	-			PT26A	1	T	
C12	PT25B	1	C		PT25B	1	C	
-	-	-			GND1	1		
D12	PT25A	1	T		PT25A	1	T	
A15	PT24B	1	C		PT24B	1	C	
B14	PT24A	1	T		PT24A	1	T	
D11	PT23B	1	C		PT23B	1	C	
C11	PT23A	1	T		PT23A	1	T	
E10	PT22B	1	C		PT22B	1	C	
E11	PT22A	1	T	TDQS22	PT22A	1	T	TDQS22
A14	PT21B	1	C		PT21B	1	C	
GND	GND1	1			GND1	1		
A13	PT21A	1	T		PT21A	1	T	
D10	PT20B	1	C		PT20B	1	C	
C10	PT20A	1	T		PT20A	1	T	
A12	PT19B	1	C	VREF2_1	PT19B	1	C	VREF2_1
B12	PT19A	1	T	VREF1_1	PT19A	1	T	VREF1_1
A11	PT18B	1	C		PT18B	1	C	
B11	PT18A	1	T		PT18A	1	T	
A10	PT17B	0	C	PCLKC0_0	PT17B	0	C	PCLKC0_0
GND	GND0	0			GND0	0		
B10	PT17A	0	T	PCLKT0_0	PT17A	0	T	PCLKT0_0
C9	PT16B	0	C	VREF1_0	PT16B	0	C	VREF1_0
B9	PT16A	0	T	VREF2_0	PT16A	0	T	VREF2_0
E9	PT15B	0	C		PT15B	0	C	
D9	PT15A	0	T		PT15A	0	T	
D8	PT14B	0	C		PT14B	0	C	
C8	PT14A	0	T	TDQS14	PT14A	0	T	TDQS14
A9	PT13B	0	C		PT13B	0	C	
GND	GND0	0			GND0	0		
A8	PT13A	0	T		PT13A	0	T	
B8	PT12B	0	C		PT12B	0	C	
B7	PT12A	0	T		PT12A	0	T	

**LFEC3 and LFECP/EC6 Logic Signal Connections: 256 fpBGA (Cont.)**

Ball Number	LFEC3				LFECP6/LFEC6			
	Ball Function	Bank	LVDS	Dual Function	Ball Function	Bank	LVDS	Dual Function
D7	PT11B	0	C		PT11B	0	C	
C7	PT11A	0	T		PT11A	0	T	
A7	PT10B	0	C		PT10B	0	C	
A6	PT10A	0	T		PT10A	0	T	
E7	PT9B	0	C		PT9B	0	C	
GND	GND0	0			GND0	0		
E6	PT9A	0	T		PT9A	0	T	
D6	PT8B	0	C		PT8B	0	C	
C6	PT8A	0	T		PT8A	0	T	
B6	PT7B	0	C		PT7B	0	C	
B5	PT7A	0	T		PT7A	0	T	
A5	PT6B	0	C		PT6B	0	C	
A4	PT6A	0	T	TDQS6	PT6A	0	T	TDQS6
A3	PT5B	0	C		PT5B	0	C	
A2	PT5A	0	T		PT5A	0	T	
B2	PT4B	0	C		PT4B	0	C	
B3	PT4A	0	T		PT4A	0	T	
D5	PT3B	0	C		PT3B	0	C	
C5	PT3A	0	T		PT3A	0	T	
C4	PT2B	0	C		PT2B	0	C	
B4	PT2A	0	T		PT2A	0	T	
GND	GND0	0			GND0	0		
A1	GND	-			GND	-		
A16	GND	-			GND	-		
G10	GND	-			GND	-		
G7	GND	-			GND	-		
G8	GND	-			GND	-		
G9	GND	-			GND	-		
H10	GND	-			GND	-		
H7	GND	-			GND	-		
H8	GND	-			GND	-		
H9	GND	-			GND	-		
J10	GND	-			GND	-		
J7	GND	-			GND	-		
J8	GND	-			GND	-		
J9	GND	-			GND	-		
K10	GND	-			GND	-		
K7	GND	-			GND	-		
K8	GND	-			GND	-		
K9	GND	-			GND	-		
T1	GND	-			GND	-		
T16	GND	-			GND	-		
E12	VCC	-			VCC	-		

**LFEC3 and LFECP/EC6 Logic Signal Connections: 256 fpBGA (Cont.)**

Ball Number	LFEC3				LFECP6/LFEC6			
	Ball Function	Bank	LVDS	Dual Function	Ball Function	Bank	LVDS	Dual Function
E5	VCC	-			VCC	-		
E8	VCC	-			VCC	-		
M12	VCC	-			VCC	-		
M5	VCC	-			VCC	-		
M9	VCC	-			VCC	-		
B15	VCCAUX	-			VCCAUX	-		
R2	VCCAUX	-			VCCAUX	-		
F7	VCCIO0	0			VCCIO0	0		
F8	VCCIO0	0			VCCIO0	0		
F10	VCCIO1	1			VCCIO1	1		
F9	VCCIO1	1			VCCIO1	1		
G11	VCCIO2	2			VCCIO2	2		
H11	VCCIO2	2			VCCIO2	2		
J11	VCCIO3	3			VCCIO3	3		
K11	VCCIO3	3			VCCIO3	3		
L10	VCCIO4	4			VCCIO4	4		
L9	VCCIO4	4			VCCIO4	4		
L7	VCCIO5	5			VCCIO5	5		
L8	VCCIO5	5			VCCIO5	5		
J6	VCCIO6	6			VCCIO6	6		
K6	VCCIO6	6			VCCIO6	6		
G6	VCCIO7	7			VCCIO7	7		
H6	VCCIO7	7			VCCIO7	7		
F6	VCC	-			VCC	-		
F11	VCC	-			VCC	-		
L11	VCC	-			VCC	-		
L6	VCC	-			VCC	-		



**LFECP/EC10 and LFECP/EC15 Logic Signal Connections: 256 fpBGA**

Ball Number	LFECP10/LFEC10				LFECP15/LFEC15			
	Ball Function	Bank	LVDS	Dual Function	Ball Function	Bank	LVDS	Dual Function
GND	GND7	7			GND7	7		
D4	PL2A	7	T	VREF2_7	PL2A	7	T	VREF2_7
D3	PL2B	7	C	VREF1_7	PL2B	7	C	VREF1_7
GND	GND7	7			GND7	7		
C3	PL12A	7	T		PL16A	7	T	
C2	PL12B	7	C		PL16B	7	C	
B1	PL13A	7	T		PL17A	7	T	
C1	PL13B	7	C		PL17B	7	C	
E3	PL14A	7	T		PL18A	7	T	
GND	GND7	7			GND7	7		
-	-	-			GND7	7		
E4	PL14B	7	C		PL18B	7	C	
F4	PL15A	7	T	LDQS15	PL19A	7	T	LDQS19
F5	PL15B	7	C		PL19B	7	C	
G4	PL16A	7	T		PL20A	7	T	
G3	PL16B	7	C		PL20B	7	C	
D2	PL17A	7	T		PL21A	7	T	
D1	PL17B	7	C		PL21B	7	C	
E1	PL18A	7	T	PCLKT7_0	PL22A	7	T	PCLKT7_0
GND	GND7	7			GND7	7		
E2	PL18B	7	C	PCLKC7_0	PL22B	7	C	PCLKC7_0
F3	XRES	6			XRES	6		
G5	PL20A	6	T		PL24A	6	T	
H5	PL20B	6	C		PL24B	6	C	
F2	PL21A	6	T		PL25A	6	T	
F1	PL21B	6	C		PL25B	6	C	
H4	PL22A	6	T		PL26A	6	T	
H3	PL22B	6	C		PL26B	6	C	
G2	PL23A	6	T		PL27A	6	T	
GND	GND6	6			GND6	6		
G1	PL23B	6	C		PL27B	6	C	
J4	PL24A	6	T	LDQS24	PL28A	6	T	LDQS28
J3	PL24B	6	C		PL28B	6	C	
J5	PL25A	6	T		PL29A	6	T	
K5	PL25B	6	C		PL29B	6	C	
H2	PL26A	6	T		PL30A	6	T	
H1	PL26B	6	C		PL30B	6	C	
J2	PL27A	6	T		PL31A	6	T	
GND	GND6	6			GND6	6		
J1	PL27B	6	C		PL31B	6	C	
K4	TCK	6			TCK	6		
K3	TDI	6			TDI	6		

**LFECP/EC10 and LFECP/EC15 Logic Signal Connections: 256 fpBGA**

Ball Number	LFECP10/LFEC10				LFECP15/LFEC15			
	Ball Function	Bank	LVDS	Dual Function	Ball Function	Bank	LVDS	Dual Function
L3	TMS	6			TMS	6		
L5	TDO	6			TDO	6		
L4	VCCJ	6			VCCJ	6		
K2	PL29A	6	T	LLM0_PLLT_IN_A	PL37A	6	T	LLM0_PLLT_IN_A
K1	PL29B	6	C	LLM0_PLLC_IN_A	PL37B	6	C	LLM0_PLLC_IN_A
L2	PL30A	6	T	LLM0_PLLT_FB_A	PL38A	6	T	LLM0_PLLT_FB_A
L1	PL30B	6	C	LLM0_PLLC_FB_A	PL38B	6	C	LLM0_PLLC_FB_A
M2	PL31A	6	T		PL39A	6	T	
M1	PL31B	6	C		PL39B	6	C	
N1	PL32A	6	T		PL40A	6	T	
GND	GND6	6			GND6	6		
-	-	-			GND6	6		
N2	PL32B	6	C		PL40B	6	C	
M4	PL33A	6	T	LDQS33	PL41A	6	T	LDQS41
M3	PL33B	6	C		PL41B	6	C	
P1	PL34A	6	T		PL42A	6	T	
R1	PL34B	6	C		PL42B	6	C	
P2	PL35A	6	T		PL43A	6	T	
P3	PL35B	6	C		PL43B	6	C	
N3	PL36A	6	T	VREF1_6	PL44A	6	T	VREF1_6
N4	PL36B	6	C	VREF2_6	PL44B	6	C	VREF2_6
GND	GND6	6			GND6	6		
GND	GND5	5			GND5	5		
GND	GND5	5			GND5	5		
P4	PB10A	5	T		PB10A	5	T	
N5	PB10B	5	C		PB10B	5	C	
P5	PB11A	5	T		PB11A	5	T	
P6	PB11B	5	C		PB11B	5	C	
R4	PB12A	5	T		PB12A	5	T	
R3	PB12B	5	C		PB12B	5	C	
T2	PB13A	5	T		PB13A	5	T	
GND	GND5	5			GND5	5		
T3	PB13B	5	C		PB13B	5	C	
R5	PB14A	5	T	BDQS14	PB14A	5	T	BDQS14
R6	PB14B	5	C		PB14B	5	C	
T4	PB15A	5	T		PB15A	5	T	
T5	PB15B	5	C		PB15B	5	C	
N6	PB16A	5	T		PB16A	5	T	
M6	PB16B	5	C		PB16B	5	C	
T6	PB17A	5	T		PB17A	5	T	
GND	GND5	5			GND5	5		
T7	PB17B	5	C		PB17B	5	C	
P7	PB18A	5	T		PB18A	5	T	

**LFECP/EC10 and LFECP/EC15 Logic Signal Connections: 256 fpBGA**

Ball Number	LFECP10/LFEC10				LFECP15/LFEC15			
	Ball Function	Bank	LVDS	Dual Function	Ball Function	Bank	LVDS	Dual Function
N7	PB18B	5	C		PB18B	5	C	
R7	PB19A	5	T		PB19A	5	T	
R8	PB19B	5	C		PB19B	5	C	
M7	PB20A	5	T		PB20A	5	T	
M8	PB20B	5	C		PB20B	5	C	
T8	PB21A	5	T		PB21A	5	T	
GND	GND5	5			GND5	5		
T9	PB21B	5	C		PB21B	5	C	
P8	PB22A	5	T	BDQS22	PB22A	5	T	BDQS22
N8	PB22B	5	C		PB22B	5	C	
R9	PB23A	5	T		PB23A	5	T	
R10	PB23B	5	C		PB23B	5	C	
P9	PB24A	5	T	VREF2_5	PB24A	5	T	VREF2_5
N9	PB24B	5	C	VREF1_5	PB24B	5	C	VREF1_5
T10	PB25A	5	T	PCLKT5_0	PB25A	5	T	PCLKT5_0
GND	GND5	5			GND5	5		
T11	PB25B	5	C	PCLKC5_0	PB25B	5	C	PCLKC5_0
T12	PB26A	4	T	WRITEN	PB26A	4	T	WRITEN
T13	PB26B	4	C	CS1N	PB26B	4	C	CS1N
P10	PB27A	4	T	VREF1_4	PB27A	4	T	VREF1_4
N10	PB27B	4	C	CSN	PB27B	4	C	CSN
T14	PB28A	4	T	VREF2_4	PB28A	4	T	VREF2_4
T15	PB28B	4	C	D0/SPID7	PB28B	4	C	D0/SPID7
M10	PB29A	4	T	D2/SPID5	PB29A	4	T	D2/SPID5
GND	GND4	4			GND4	4		
M11	PB29B	4	C	D1/SPID6	PB29B	4	C	D1/SPID6
R11	PB30A	4	T	BDQS30	PB30A	4	T	BDQS30
P11	PB30B	4	C	D3/SPID4	PB30B	4	C	D3/SPID4
R13	PB31A	4	T		PB31A	4	T	
R14	PB31B	4	C	D4/SPID3	PB31B	4	C	D4/SPID3
P12	PB32A	4	T		PB32A	4	T	
P13	PB32B	4	C	D5/SPID2	PB32B	4	C	D5/SPID2
N11	PB33A	4	T		PB33A	4	T	
GND	GND4	4			GND4	4		
N12	PB33B	4	C	D6/SPID1	PB33B	4	C	D6/SPID1
R12	PB34A	4			PB34A	4		
GND	GND4	4			GND4	4		
GND	GND4	4			GND4	4		
-	-	-			GND4	4		
-	-	-			GND4	4		
GND	GND3	3			GND3	3		
N13	PR36B	3	C	VREF2_3	PR44B	3	C	VREF2_3
N14	PR36A	3	T	VREF1_3	PR44A	3	T	VREF1_3

**LFCEP/EC10 and LFCEP/EC15 Logic Signal Connections: 256 fpBGA**

Ball Number	LFCEP10/LFCEP10				LFCEP15/LFCEP15			
	Ball Function	Bank	LVDS	Dual Function	Ball Function	Bank	LVDS	Dual Function
P14	PR35B	3	C		PR43B	3	C	
P15	PR35A	3	T		PR43A	3	T	
R15	PR34B	3	C		PR42B	3	C	
R16	PR34A	3	T		PR42A	3	T	
M13	PR33B	3	C		PR41B	3	C	
M14	PR33A	3	T	RDQS33	PR41A	3	T	RDQS41
P16	PR32B	3	C	RLM0_PLLC_FB_A	PR40B	3	C	RLM0_PLLC_FB_A
GND	GND3	3			GND3	3		
N16	PR32A	3	T	RLM0_PLLT_FB_A	PR40A	3	T	RLM0_PLLT_FB_A
N15	PR31B	3	C	RLM0_PLLC_IN_A	PR39B	3	C	RLM0_PLLC_IN_A
M15	PR31A	3	T	RLM0_PLLT_IN_A	PR39A	3	T	RLM0_PLLT_IN_A
M16	PR30B	3	C	DI/CSSPIN	PR38B	3	C	DI/CSSPIN
L16	PR30A	3	T	DOU/CSON	PR38A	3	T	DOU/CSON
K16	PR29B	3	C	BUSY/SISPI	PR37B	3	C	BUSY/SISPI
J16	PR29A	3	T	D7/SPID0	PR37A	3	T	D7/SPID0
L12	CFG2	3			CFG2	3		
L14	CFG1	3			CFG1	3		
L13	CFG0	3			CFG0	3		
K13	PROGRAMN	3			PROGRAMN	3		
L15	CCLK	3			CCLK	3		
K15	INITN	3			INITN	3		
K14	DONE	3			DONE	3		
GND	GND3	3			GND3	3		
H16	PR27B	3	C		PR31B	3	C	
-	-	-			GND3	3		
H15	PR27A	3	T		PR31A	3	T	
G16	PR26B	3	C		PR30B	3	C	
G15	PR26A	3	T		PR30A	3	T	
K12	PR25B	3	C		PR29B	3	C	
J12	PR25A	3	T		PR29A	3	T	
J14	PR24B	3	C		PR28B	3	C	
J15	PR24A	3	T	RDQS24	PR28A	3	T	RDQS28
F16	PR23B	3	C		PR27B	3	C	
GND	GND3	3			GND3	3		
F15	PR23A	3	T		PR27A	3	T	
J13	PR22B	3	C		PR26B	3	C	
H13	PR22A	3	T		PR26A	3	T	
H14	PR21B	3	C		PR25B	3	C	
G14	PR21A	3	T		PR25A	3	T	
E16	PR20B	3	C		PR24B	3	C	
E15	PR20A	3	T		PR24A	3	T	
H12	PR18B	2	C	PCLKC2_0	PR22B	2	C	PCLKC2_0
GND	GND2	2			GND2	2		

**LFCEP/EC10 and LFCEP/EC15 Logic Signal Connections: 256 fpBGA**

Ball Number	LFCEP10/LFCEP10				LFCEP15/LFCEP15			
	Ball Function	Bank	LVDS	Dual Function	Ball Function	Bank	LVDS	Dual Function
G12	PR18A	2	T	PCLKT2_0	PR22A	2	T	PCLKT2_0
G13	PR17B	2	C		PR21B	2	C	
F13	PR17A	2	T		PR21A	2	T	
F12	PR16B	2	C		PR20B	2	C	
E13	PR16A	2	T		PR20A	2	T	
D16	PR15B	2	C		PR19B	2	C	
D15	PR15A	2	T		PR19A	2	T	RDQS19
F14	PR14B	2	C		PR18B	2	C	
GND	GND2	2			GND2	2		
E14	PR14A	2	T		PR18A	2	T	
C16	PR13B	2	C		PR17B	2	C	
B16	PR13A	2	T		PR17A	2	T	
C15	PR12B	2	C		PR16B	2	C	
C14	PR12A	2	T		PR16A	2	T	
GND	GND2	2			GND2	2		
-	-	-			GND2	2		
D14	PR2B	2	C	VREF1_2	PR2B	2	C	VREF1_2
D13	PR2A	2	T	VREF2_2	PR2A	2	T	VREF2_2
GND	GND2	2			GND2	2		
GND	GND1	1			GND1	1		
GND	GND1	1			GND1	1		
-	-	-			GND1	1		
-	-	-			GND1	1		
B13	PT34B	1	C		PT34B	1	C	
C13	PT34A	1	T		PT34A	1	T	
C12	PT33B	1	C		PT33B	1	C	
GND	GND1	1			GND1	1		
D12	PT33A	1	T		PT33A	1	T	
A15	PT32B	1	C		PT32B	1	C	
B14	PT32A	1	T		PT32A	1	T	
D11	PT31B	1	C		PT31B	1	C	
C11	PT31A	1	T		PT31A	1	T	
E10	PT30B	1	C		PT30B	1	C	
E11	PT30A	1	T	TDQS30	PT30A	1	T	TDQS30
A14	PT29B	1	C		PT29B	1	C	
GND	GND1	1			GND1	1		
A13	PT29A	1	T		PT29A	1	T	
D10	PT28B	1	C		PT28B	1	C	
C10	PT28A	1	T		PT28A	1	T	
A12	PT27B	1	C	VREF2_1	PT27B	1	C	VREF2_1
B12	PT27A	1	T	VREF1_1	PT27A	1	T	VREF1_1
A11	PT26B	1	C		PT26B	1	C	
B11	PT26A	1	T		PT26A	1	T	

**LFECP/EC10 and LFECP/EC15 Logic Signal Connections: 256 fpBGA**

Ball Number	LFECP10/LFEC10				LFECP15/LFEC15			
	Ball Function	Bank	LVDS	Dual Function	Ball Function	Bank	LVDS	Dual Function
A10	PT25B	0	C	PCLKC0_0	PT25B	0	C	PCLKC0_0
GND	GND0	0			GND0	0		
B10	PT25A	0	T	PCLKT0_0	PT25A	0	T	PCLKT0_0
C9	PT24B	0	C	VREF1_0	PT24B	0	C	VREF1_0
B9	PT24A	0	T	VREF2_0	PT24A	0	T	VREF2_0
E9	PT23B	0	C		PT23B	0	C	
D9	PT23A	0	T		PT23A	0	T	
D8	PT22B	0	C		PT22B	0	C	
C8	PT22A	0	T	TDQS22	PT22A	0	T	TDQS22
A9	PT21B	0	C		PT21B	0	C	
GND	GND0	0			GND0	0		
A8	PT21A	0	T		PT21A	0	T	
B8	PT20B	0	C		PT20B	0	C	
B7	PT20A	0	T		PT20A	0	T	
D7	PT19B	0	C		PT19B	0	C	
C7	PT19A	0	T		PT19A	0	T	
A7	PT18B	0	C		PT18B	0	C	
A6	PT18A	0	T		PT18A	0	T	
E7	PT17B	0	C		PT17B	0	C	
GND	GND0	0			GND0	0		
E6	PT17A	0	T		PT17A	0	T	
D6	PT16B	0	C		PT16B	0	C	
C6	PT16A	0	T		PT16A	0	T	
B6	PT15B	0	C		PT15B	0	C	
B5	PT15A	0	T		PT15A	0	T	
A5	PT14B	0	C		PT14B	0	C	
A4	PT14A	0	T	TDQS14	PT14A	0	T	TDQS14
A3	PT13B	0	C		PT13B	0	C	
-	GND0	0			GND0	0		
A2	PT13A	0	T		PT13A	0	T	
B2	PT12B	0	C		PT12B	0	C	
B3	PT12A	0	T		PT12A	0	T	
D5	PT11B	0	C		PT11B	0	C	
C5	PT11A	0	T		PT11A	0	T	
C4	PT10B	0	C		PT10B	0	C	
B4	PT10A	0	T		PT10A	0	T	
GND	GND0	0			GND0	0		
GND	GND0	0			GND0	0		
A1	GND	-			GND	-		
A16	GND	-			GND	-		
G10	GND	-			GND	-		
G7	GND	-			GND	-		
G8	GND	-			GND	-		

**LFECP/EC10 and LFECP/EC15 Logic Signal Connections: 256 fpBGA**

Ball Number	LFECP10/LFEC10				LFECP15/LFEC15			
	Ball Function	Bank	LVDS	Dual Function	Ball Function	Bank	LVDS	Dual Function
G9	GND	-			GND	-		
H10	GND	-			GND	-		
H7	GND	-			GND	-		
H8	GND	-			GND	-		
H9	GND	-			GND	-		
J10	GND	-			GND	-		
J7	GND	-			GND	-		
J8	GND	-			GND	-		
J9	GND	-			GND	-		
K10	GND	-			GND	-		
K7	GND	-			GND	-		
K8	GND	-			GND	-		
K9	GND	-			GND	-		
T1	GND	-			GND	-		
T16	GND	-			GND	-		
E12	VCC	-			VCC	-		
E5	VCC	-			VCC	-		
E8	VCC	-			VCC	-		
M12	VCC	-			VCC	-		
M5	VCC	-			VCC	-		
M9	VCC	-			VCC	-		
B15	VCCAUX	-			VCCAUX	-		
R2	VCCAUX	-			VCCAUX	-		
F7	VCCIO0	0			VCCIO0	0		
F8	VCCIO0	0			VCCIO0	0		
F10	VCCIO1	1			VCCIO1	1		
F9	VCCIO1	1			VCCIO1	1		
G11	VCCIO2	2			VCCIO2	2		
H11	VCCIO2	2			VCCIO2	2		
J11	VCCIO3	3			VCCIO3	3		
K11	VCCIO3	3			VCCIO3	3		
L10	VCCIO4	4			VCCIO4	4		
L9	VCCIO4	4			VCCIO4	4		
L7	VCCIO5	5			VCCIO5	5		
L8	VCCIO5	5			VCCIO5	5		
J6	VCCIO6	6			VCCIO6	6		
K6	VCCIO6	6			VCCIO6	6		
G6	VCCIO7	7			VCCIO7	7		
H6	VCCIO7	7			VCCIO7	7		
F6	VCC	-			VCC	-		
F11	VCC	-			VCC	-		
L11	VCC	-			VCC	-		
L6	VCC	-			VCC	-		

**LFECP/EC6, LFECP/EC10, LFECP/EC15 Logic Signal Connections:  
484 fpBGA**

LFECP6/LFEC6					LFECP10/LFEC10					LFECP/LFEC15				
Ball Number	Ball Function	Bank	LVDS	Dual Function	Ball Number	Ball Function	Bank	LVDS	Dual Function	Ball Number	Ball Function	Bank	LVDS	Dual Function
GND	GND7	7			GND	GND7	7			GND	GND7	7		
D4	PL2A	7	T	VREF2_7	D4	PL2A	7	T	VREF2_7	D4	PL2A	7	T	VREF2_7
E4	PL2B	7	C	VREF1_7	E4	PL2B	7	C	VREF1_7	E4	PL2B	7	C	VREF1_7
C3	NC	-			C3	PL3A	7	T		C3	PL3A	7	T	
B2	NC	-			B2	PL3B	7	C		B2	PL3B	7	C	
E5	NC	-			E5	PL4A	7	T		E5	PL4A	7	T	
F5	NC	-			F5	PL4B	7	C		F5	PL4B	7	C	
D3	NC	-			D3	PL5A	7	T		D3	PL5A	7	T	
C2	NC	-			C2	PL5B	7	C		C2	PL5B	7	C	
F4	NC	-			F4	PL6A	7	T	LDQS6	F4	PL6A	7	T	LDQS6
G4	NC	-			G4	PL6B	7	C		G4	PL6B	7	C	
E3	NC	-			E3	PL7A	7	T		E3	PL7A	7	T	
D2	NC	-			D2	PL7B	7	C		D2	PL7B	7	C	
B1	NC	-			B1	PL8A	7	T	LUM0_PLLT_IN_A	B1	PL8A	7	T	LUM0_PLLT_IN_A
C1	NC	-			C1	PL8B	7	C	LUM0_PLLC_IN_A	C1	PL8B	7	C	LUM0_PLLC_IN_A
F3	NC	-			F3	PL9A	7	T	LUM0_PLLT_FB_A	F3	PL9A	7	T	LUM0_PLLT_FB_A
GND	-	-			GND	GND7	7			GND	GND7	7		
E2	NC	-			E2	PL9B	7	C	LUM0_PLLC_FB_A	E2	PL9B	7	C	LUM0_PLLC_FB_A
G5	NC	-			G5	NC	-			G5	PL11A	7	T	
H6	NC	-			H6	NC	-			H6	PL11B	7	C	
G3	NC	-			G3	NC	-			G3	PL12A	7	T	
H4	NC	-			H4	NC	-			H4	PL12B	7	C	
J5	NC	-			J5	NC	-			J5	PL13A	7	T	
H5	NC	-			H5	NC	-			H5	PL13B	7	C	
F2	NC	-			F2	NC	-			F2	PL14A	7	T	
GND	-	-			GND	-	-			GND	GND7	7		
F1	NC	-			F1	NC	-			F1	PL14B	7	C	
E1	NC	-			E1	PL11A	7	T		E1	PL15A	7	T	
D1	NC	-			D1	PL11B	7	C		D1	PL15B	7	C	
H3	PL3A	7	T		H3	PL12A	7	T		H3	PL16A	7	T	
G2	PL3B	7	C		G2	PL12B	7	C		G2	PL16B	7	C	
H2	PL4A	7	T		H2	PL13A	7	T		H2	PL17A	7	T	
G1	PL4B	7	C		G1	PL13B	7	C		G1	PL17B	7	C	
J4	PL5A	7	T		J4	PL14A	7	T		J4	PL18A	7	T	
GND	-	-			GND	GND7	7			GND	GND7	7		
J3	PL5B	7	C		J3	PL14B	7	C		J3	PL18B	7	C	
J2	PL6A	7	T	LDQS6	J2	PL15A	7	T	LDQS15	J2	PL19A	7	T	LDQS19
H1	PL6B	7	C		H1	PL15B	7	C		H1	PL19B	7	C	
K4	PL7A	7	T		K4	PL16A	7	T		K4	PL20A	7	T	
K5	PL7B	7	C		K5	PL16B	7	C		K5	PL20B	7	C	
K3	PL8A	7	T		K3	PL17A	7	T		K3	PL21A	7	T	
K2	PL8B	7	C		K2	PL17B	7	C		K2	PL21B	7	C	
J1	PL9A	7	T	PCLKT7_0	J1	PL18A	7	T	PCLKT7_0	J1	PL22A	7	T	PCLKT7_0
GND	GND7	7			GND	GND7	7			GND	GND7	7		
K1	PL9B	7	C	PCLKC7_0	K1	PL18B	7	C	PCLKC7_0	K1	PL22B	7	C	PCLKC7_0
L3	XRES	6			L3	XRES	6			L3	XRES	6		
L4	PL11A	6	T		L4	PL20A	6	T		L4	PL24A	6	T	
L5	PL11B	6	C		L5	PL20B	6	C		L5	PL24B	6	C	
L2	PL12A	6	T		L2	PL21A	6	T		L2	PL25A	6	T	
L1	PL12B	6	C		L1	PL21B	6	C		L1	PL25B	6	C	



**LFECF/EC6, LFECF/EC10, LFECF/EC15 Logic Signal Connections:  
484 fpBGA (Cont.)**

LFECF6/LFEC6					LFECF10/LFEC10					LFECF15/LFEC15				
Ball Number	Ball Function	Bank	LVDS	Dual Function	Ball Number	Ball Function	Bank	LVDS	Dual Function	Ball Number	Ball Function	Bank	LVDS	Dual Function
M4	PL13A	6	T		M4	PL22A	6	T		M4	PL26A	6	T	
M5	PL13B	6	C		M5	PL22B	6	C		M5	PL26B	6	C	
M1	PL14A	6	T		M1	PL23A	6	T		M1	PL27A	6	T	
GND	GND6	6			GND	GND6	6			GND	GND6	6		
M2	PL14B	6	C		M2	PL23B	6	C		M2	PL27B	6	C	
N3	PL15A	6	T	LDQS15	N3	PL24A	6	T	LDQS24	N3	PL28A	6	T	LDQS28
M3	PL15B	6	C		M3	PL24B	6	C		M3	PL28B	6	C	
N5	PL16A	6	T		N5	PL25A	6	T		N5	PL29A	6	T	
N4	PL16B	6	C		N4	PL25B	6	C		N4	PL29B	6	C	
N1	PL17A	6	T		N1	PL26A	6	T		N1	PL30A	6	T	
N2	PL17B	6	C		N2	PL26B	6	C		N2	PL30B	6	C	
P1	PL18A	6	T		P1	PL27A	6	T		P1	PL31A	6	T	
GND	GND6	6			GND	GND6	6			GND	GND6	6		
P2	PL18B	6	C		P2	PL27B	6	C		P2	PL31B	6	C	
R6	NC	-			R6	NC	-			R6	PL32A	6	T	
P5	NC	-			P5	NC	-			P5	PL32B	6	C	
P3	NC	-			P3	NC	-			P3	PL33A	6	T	
P4	NC	-			P4	NC	-			P4	PL33B	6	C	
R1	NC	-			R1	NC	-			R1	PL34A	6	T	
R2	NC	-			R2	NC	-			R2	PL34B	6	C	
R5	NC	-			R5	NC	-			R5	PL35A	6	T	
GND	-	-			-	-	-			GND	GND6	6		
R4	NC	-			R4	NC	-			R4	PL35B	6	C	
T1	NC	-			T1	NC	-			T1	NC	-		
T2	NC	-			T2	NC	-			T2	NC	-		
R3	NC	-			R3	NC	-			R3	NC	-		
T3	NC	-			T3	NC	-			T3	NC	-		
T5	TCK	6			T5	TCK	6			T5	TCK	6		
U5	TDI	6			U5	TDI	6			U5	TDI	6		
T4	TMS	6			T4	TMS	6			T4	TMS	6		
U1	TDO	6			U1	TDO	6			U1	TDO	6		
U2	VCCJ	6			U2	VCCJ	6			U2	VCCJ	6		
V1	PL20A	6	T	LLM0_PLLT_IN_A	V1	PL29A	6	T	LLM0_PLLT_IN_A	V1	PL37A	6	T	LLM0_PLLT_IN_A
V2	PL20B	6	C	LLM0_PLLC_IN_A	V2	PL29B	6	C	LLM0_PLLC_IN_A	V2	PL37B	6	C	LLM0_PLLC_IN_A
U3	PL21A	6	T	LLM0_PLLT_FB_A	U3	PL30A	6	T	LLM0_PLLT_FB_A	U3	PL38A	6	T	LLM0_PLLT_FB_A
V3	PL21B	6	C	LLM0_PLLC_FB_A	V3	PL30B	6	C	LLM0_PLLC_FB_A	V3	PL38B	6	C	LLM0_PLLC_FB_A
U4	PL22A	6	T		U4	PL31A	6	T		U4	PL39A	6	T	
V5	PL22B	6	C		V5	PL31B	6	C		V5	PL39B	6	C	
W1	PL23A	6	T		W1	PL32A	6	T		W1	PL40A	6	T	
GND	GND6	6			GND	GND6	6			GND	GND6	6		
W2	PL23B	6	C		W2	PL32B	6	C		W2	PL40B	6	C	
Y1	PL24A	6	T	LDQS24	Y1	PL33A	6	T	LDQS33	Y1	PL41A	6	T	LDQS41
Y2	PL24B	6	C		Y2	PL33B	6	C		Y2	PL41B	6	C	
AA1	PL25A	6	T		AA1	PL34A	6	T		AA1	PL42A	6	T	
AA2	PL25B	6	C		AA2	PL34B	6	C		AA2	PL42B	6	C	
W4	PL26A	6	T		W4	PL35A	6	T		W4	PL43A	6	T	
V4	PL26B	6	C		V4	PL35B	6	C		V4	PL43B	6	C	
W3	PL27A	6	T	VREF1_6	W3	PL36A	6	T	VREF1_6	W3	PL44A	6	T	VREF1_6
Y3	PL27B	6	C	VREF2_6	Y3	PL36B	6	C	VREF2_6	Y3	PL44B	6	C	VREF2_6
GND	GND6	6			GND	GND6	6			GND	GND6	6		

**LFECP/EC6, LFECP/EC10, LFECP/EC15 Logic Signal Connections:  
484 fpBGA (Cont.)**

LFECP6/LFEC6					LFECP10/LFEC10					LFECP/LFEC15				
Ball Number	Ball Function	Bank	LVDS	Dual Function	Ball Number	Ball Function	Bank	LVDS	Dual Function	Ball Number	Ball Function	Bank	LVDS	Dual Function
GND	GND5	5			GND	GND5	5			GND	GND5	5		
V7	NC	-			V7	PB2A	5	T		V7	PB2A	5	T	
T6	NC	-			T6	PB2B	5	C		T6	PB2B	5	C	
V8	NC	-			V8	PB3A	5	T		V8	PB3A	5	T	
U7	NC	-			U7	PB3B	5	C		U7	PB3B	5	C	
W5	NC	-			W5	PB4A	5	T		W5	PB4A	5	T	
U6	NC	-			U6	PB4B	5	C		U6	PB4B	5	C	
AA3	NC	-			AA3	PB5A	5	T		AA3	PB5A	5	T	
AB3	NC	-			AB3	PB5B	5	C		AB3	PB5B	5	C	
Y6	NC	-			Y6	PB6A	5	T	BDQS6	Y6	PB6A	5	T	BDQS6
V6	NC	-			V6	PB6B	5	C		V6	PB6B	5	C	
AA5	NC	-			AA5	PB7A	5	T		AA5	PB7A	5	T	
W6	NC	-			W6	PB7B	5	C		W6	PB7B	5	C	
Y5	NC	-			Y5	PB8A	5	T		Y5	PB8A	5	T	
Y4	NC	-			Y4	PB8B	5	C		Y4	PB8B	5	C	
AA4	NC	-			AA4	PB9A	5	T		AA4	PB9A	5	T	
GND	-	-			GND	GND5	5			GND	GND5	5		
AB4	NC	-			AB4	PB9B	5	C		AB4	PB9B	5	C	
Y7	PB2A	5	T		Y7	PB10A	5	T		Y7	PB10A	5	T	
W8	PB2B	5	C		W8	PB10B	5	C		W8	PB10B	5	C	
W7	PB3A	5	T		W7	PB11A	5	T		W7	PB11A	5	T	
U8	PB3B	5	C		U8	PB11B	5	C		U8	PB11B	5	C	
W9	PB4A	5	T		W9	PB12A	5	T		W9	PB12A	5	T	
U9	PB4B	5	C		U9	PB12B	5	C		U9	PB12B	5	C	
Y8	PB5A	5	T		Y8	PB13A	5	T		Y8	PB13A	5	T	
GND	-	-			GND	GND5	5			GND	GND5	5		
Y9	PB5B	5	C		Y9	PB13B	5	C		Y9	PB13B	5	C	
V9	PB6A	5	T	BDQS6	V9	PB14A	5	T	BDQS14	V9	PB14A	5	T	BDQS14
T9	PB6B	5	C		T9	PB14B	5	C		T9	PB14B	5	C	
W10	PB7A	5	T		W10	PB15A	5	T		W10	PB15A	5	T	
U10	PB7B	5	C		U10	PB15B	5	C		U10	PB15B	5	C	
V10	PB8A	5	T		V10	PB16A	5	T		V10	PB16A	5	T	
T10	PB8B	5	C		T10	PB16B	5	C		T10	PB16B	5	C	
AA6	PB9A	5	T		AA6	PB17A	5	T		AA6	PB17A	5	T	
GND	GND5	5			GND	GND5	5			GND	GND5	5		
AB5	PB9B	5	C		AB5	PB17B	5	C		AB5	PB17B	5	C	
AA8	PB10A	5	T		AA8	PB18A	5	T		AA8	PB18A	5	T	
AA7	PB10B	5	C		AA7	PB18B	5	C		AA7	PB18B	5	C	
AB6	PB11A	5	T		AB6	PB19A	5	T		AB6	PB19A	5	T	
AB7	PB11B	5	C		AB7	PB19B	5	C		AB7	PB19B	5	C	
Y10	PB12A	5	T		Y10	PB20A	5	T		Y10	PB20A	5	T	
W11	PB12B	5	C		W11	PB20B	5	C		W11	PB20B	5	C	
AB8	PB13A	5	T		AB8	PB21A	5	T		AB8	PB21A	5	T	
GND	GND5	5			GND	GND5	5			GND	GND5	5		
AB9	PB13B	5	C		AB9	PB21B	5	C		AB9	PB21B	5	C	
AA10	PB14A	5	T	BDQS14	AA10	PB22A	5	T	BDQS22	AA10	PB22A	5	T	BDQS22
AA9	PB14B	5	C		AA9	PB22B	5	C		AA9	PB22B	5	C	
Y11	PB15A	5	T		Y11	PB23A	5	T		Y11	PB23A	5	T	
AA11	PB15B	5	C		AA11	PB23B	5	C		AA11	PB23B	5	C	
V11	PB16A	5	T	VREF2_5	V11	PB24A	5	T	VREF2_5	V11	PB24A	5	T	VREF2_5

**LFECP/EC6, LFECP/EC10, LFECP/EC15 Logic Signal Connections:  
484 fpBGA (Cont.)**

LFECP6/LFEC6					LFECP10/LFEC10					LFECP/EC15				
Ball Number	Ball Function	Bank	LVDS	Dual Function	Ball Number	Ball Function	Bank	LVDS	Dual Function	Ball Number	Ball Function	Bank	LVDS	Dual Function
V12	PB16B	5	C	VREF1_5	V12	PB24B	5	C	VREF1_5	V12	PB24B	5	C	VREF1_5
AB10	PB17A	5	T	PCLKT5_0	AB10	PB25A	5	T	PCLKT5_0	AB10	PB25A	5	T	PCLKT5_0
GND	GND5	5			GND	GND5	5			GND	GND5	5		
AB11	PB17B	5	C	PCLKC5_0	AB11	PB25B	5	C	PCLKC5_0	AB11	PB25B	5	C	PCLKC5_0
Y12	PB18A	4	T	WRITEN	Y12	PB26A	4	T	WRITEN	Y12	PB26A	4	T	WRITEN
U11	PB18B	4	C	CS1N	U11	PB26B	4	C	CS1N	U11	PB26B	4	C	CS1N
W12	PB19A	4	T	VREF1_4	W12	PB27A	4	T	VREF1_4	W12	PB27A	4	T	VREF1_4
U12	PB19B	4	C	CSN	U12	PB27B	4	C	CSN	U12	PB27B	4	C	CSN
W13	PB20A	4	T	VREF2_4	W13	PB28A	4	T	VREF2_4	W13	PB28A	4	T	VREF2_4
U13	PB20B	4	C	D0/SPID7	U13	PB28B	4	C	D0/SPID7	U13	PB28B	4	C	D0/SPID7
AA12	PB21A	4	T	D2/SPID5	AA12	PB29A	4	T	D2/SPID5	AA12	PB29A	4	T	D2/SPID5
GND	GND4	4			GND	GND4	4			GND	GND4	4		
AB12	PB21B	4	C	D1/SPID6	AB12	PB29B	4	C	D1/SPID6	AB12	PB29B	4	C	D1/SPID6
T13	PB22A	4	T	BDQS22	T13	PB30A	4	T	BDQS30	T13	PB30A	4	T	BDQS30
V13	PB22B	4	C	D3/SPID4	V13	PB30B	4	C	D3/SPID4	V13	PB30B	4	C	D3/SPID4
W14	PB23A	4	T		W14	PB31A	4	T		W14	PB31A	4	T	
U14	PB23B	4	C	D4/SPID3	U14	PB31B	4	C	D4/SPID3	U14	PB31B	4	C	D4/SPID3
Y13	PB24A	4	T		Y13	PB32A	4	T		Y13	PB32A	4	T	
V14	PB24B	4	C	D5/SPID2	V14	PB32B	4	C	D5/SPID2	V14	PB32B	4	C	D5/SPID2
AA13	PB25A	4	T		AA13	PB33A	4	T		AA13	PB33A	4	T	
GND	GND4	4			GND	GND4	4			GND	GND4	4		
AB13	PB25B	4	C	D6/SPID1	AB13	PB33B	4	C	D6/SPID1	AB13	PB33B	4	C	D6/SPID1
AA14	PB26A	4	T		AA14	PB34A	4	T		AA14	PB34A	4	T	
Y14	PB26B	4	C		Y14	PB34B	4	C		Y14	PB34B	4	C	
Y15	PB27A	4	T		Y15	PB35A	4	T		Y15	PB35A	4	T	
W15	PB27B	4	C		W15	PB35B	4	C		W15	PB35B	4	C	
V15	PB28A	4	T		V15	PB36A	4	T		V15	PB36A	4	T	
T14	PB28B	4	C		T14	PB36B	4	C		T14	PB36B	4	C	
AB14	PB29A	4	T		AB14	PB37A	4	T		AB14	PB37A	4	T	
GND	GND4	4			GND	GND4	4			GND	GND4	4		
AB15	PB29B	4	C		AB15	PB37B	4	C		AB15	PB37B	4	C	
AB16	PB30A	4	T	BDQS30	AB16	PB38A	4	T	BDQS38	AB16	PB38A	4	T	BDQS38
AA15	PB30B	4	C		AA15	PB38B	4	C		AA15	PB38B	4	C	
AB17	PB31A	4	T		AB17	PB39A	4	T		AB17	PB39A	4	T	
AA16	PB31B	4	C		AA16	PB39B	4	C		AA16	PB39B	4	C	
AB18	PB32A	4	T		AB18	PB40A	4	T		AB18	PB40A	4	T	
AA17	PB32B	4	C		AA17	PB40B	4	C		AA17	PB40B	4	C	
AB19	PB33A	4	T		AB19	PB41A	4	T		AB19	PB41A	4	T	
GND	-	-			GND	-	-			GND	GND4	4		
AA18	PB33B	4	C		AA18	PB41B	4	C		AA18	PB41B	4	C	
W16	NC	-			W16	NC	-			W16	PB42A	4	T	
U15	NC	-			U15	NC	-			U15	PB42B	4	C	
V16	NC	-			V16	NC	-			V16	PB43A	4	T	
U16	NC	-			U16	NC	-			U16	PB43B	4	C	
Y17	NC	-			Y17	NC	-			Y17	PB44A	4	T	
V17	NC	-			V17	NC	-			V17	PB44B	4	C	
AB20	NC	-			AB20	NC	-			AB20	PB45A	4	T	
GND	-	-			GND	-	-			GND	GND4	4		
AA19	NC	-			AA19	NC	-			AA19	PB45B	4	C	
Y16	NC	-			Y16	NC	-			Y16	PB46A	4	T	BDQS46

**LFECP/EC6, LFECP/EC10, LFECP/EC15 Logic Signal Connections:  
484 fpBGA (Cont.)**

LFECP6/LFEC6					LFECP10/LFEC10					LFECP/LFEC15				
Ball Number	Ball Function	Bank	LVDS	Dual Function	Ball Number	Ball Function	Bank	LVDS	Dual Function	Ball Number	Ball Function	Bank	LVDS	Dual Function
W17	NC	-			W17	NC	-			W17	PB46B	4	C	
AA20	NC	-			AA20	NC	-			AA20	PB47A	4	T	
Y19	NC	-			Y19	NC	-			Y19	PB47B	4	C	
Y18	NC	-			Y18	NC	-			Y18	PB48A	4	T	
W18	NC	-			W18	NC	-			W18	PB48B	4	C	
T17	NC	-			T17	NC	-			T17	PB49A	4	T	
U17	NC	-			U17	NC	-			U17	PB49B	4	C	
GND	GND4	4			GND	GND4	4			GND	GND4	4		
GND	GND3	3			GND	GND3	3			GND	GND3	3		
W20	PR27B	3	C	VREF2_3	W20	PR36B	3	C	VREF2_3	W20	PR44B	3	C	VREF2_3
Y20	PR27A	3	T	VREF1_3	Y20	PR36A	3	T	VREF1_3	Y20	PR44A	3	T	VREF1_3
AA21	PR26B	3	C		AA21	PR35B	3	C		AA21	PR43B	3	C	
AB21	PR26A	3	T		AB21	PR35A	3	T		AB21	PR43A	3	T	
W19	PR25B	3	C		W19	PR34B	3	C		W19	PR42B	3	C	
V19	PR25A	3	T		V19	PR34A	3	T		V19	PR42A	3	T	
Y21	PR24B	3	C		Y21	PR33B	3	C		Y21	PR41B	3	C	
AA22	PR24A	3	T	RDQS24	AA22	PR33A	3	T	RDQS33	AA22	PR41A	3	T	RDQS41
V20	PR23B	3	C	RLM0_PLLC_FB_A	V20	PR32B	3	C	RLM0_PLLC_FB_A	V20	PR40B	3	C	RLM0_PLLC_FB_A
GND	GND3	3			GND	GND3	3			GND	GND3	3		
U20	PR23A	3	T	RLM0_PLLT_FB_A	U20	PR32A	3	T	RLM0_PLLT_FB_A	U20	PR40A	3	T	RLM0_PLLT_FB_A
W21	PR22B	3	C	RLM0_PLLC_IN_A	W21	PR31B	3	C	RLM0_PLLC_IN_A	W21	PR39B	3	C	RLM0_PLLC_IN_A
Y22	PR22A	3	T	RLM0_PLLT_IN_A	Y22	PR31A	3	T	RLM0_PLLT_IN_A	Y22	PR39A	3	T	RLM0_PLLT_IN_A
V21	PR21B	3	C	DI/CSSPIN	V21	PR30B	3	C	DI/CSSPIN	V21	PR38B	3	C	DI/CSSPIN
W22	PR21A	3	T	DOUT/CSON	W22	PR30A	3	T	DOUT/CSON	W22	PR38A	3	T	DOUT/CSON
U21	PR20B	3	C	BUSY/SISPI	U21	PR29B	3	C	BUSY/SISPI	U21	PR37B	3	C	BUSY/SISPI
V22	PR20A	3	T	D7/SPID0	V22	PR29A	3	T	D7/SPID0	V22	PR37A	3	T	D7/SPID0
T19	CFG2	3			T19	CFG2	3			T19	CFG2	3		
U19	CFG1	3			U19	CFG1	3			U19	CFG1	3		
U18	CFG0	3			U18	CFG0	3			U18	CFG0	3		
V18	PROGRAMN	3			V18	PROGRAMN	3			V18	PROGRAMN	3		
T20	CCLK	3			T20	CCLK	3			T20	CCLK	3		
T21	INITN	3			T21	INITN	3			T21	INITN	3		
R20	DONE	3			R20	DONE	3			R20	DONE	3		
T18	NC	-			T18	NC	-			T18	NC	-		
R17	NC	-			R17	NC	-			R17	NC	-		
R19	NC	-			R19	NC	-			R19	NC	-		
R18	NC	-			R18	NC	-			R18	NC	-		
U22	NC	-			U22	NC	-			U22	PR35B	3	C	
GND	-	-			GND	-	-			GND	GND3	3		
T22	NC	-			T22	NC	-			T22	PR35A	3	T	
R21	NC	-			R21	NC	-			R21	PR34B	3	C	
R22	NC	-			R22	NC	-			R22	PR34A	3	T	
P20	NC	-			P20	NC	-			P20	PR33B	3	C	
N20	NC	-			N20	NC	-			N20	PR33A	3	T	
P19	NC	-			P19	NC	-			P19	PR32B	3	C	
P18	NC	-			P18	NC	-			P18	PR32A	3	T	
P21	PR18B	3	C		P21	PR27B	3	C		P21	PR31B	3	C	
GND	GND3	3			GND	GND3	3			GND	GND3	3		
P22	PR18A	3	T		P22	PR27A	3	T		P22	PR31A	3	T	
N21	PR17B	3	C		N21	PR26B	3	C		N21	PR30B	3	C	

**LFECP/EC6, LFECP/EC10, LFECP/EC15 Logic Signal Connections:  
484 fpBGA (Cont.)**

LFECP6/LFEC6					LFECP10/LFEC10					LFECP/LFEC15				
Ball Number	Ball Function	Bank	LVDS	Dual Function	Ball Number	Ball Function	Bank	LVDS	Dual Function	Ball Number	Ball Function	Bank	LVDS	Dual Function
N22	PR17A	3	T		N22	PR26A	3	T		N22	PR30A	3	T	
N19	PR16B	3	C		N19	PR25B	3	C		N19	PR29B	3	C	
N18	PR16A	3	T		N18	PR25A	3	T		N18	PR29A	3	T	
M21	PR15B	3	C		M21	PR24B	3	C		M21	PR28B	3	C	
L20	PR15A	3	T	RDQS15	L20	PR24A	3	T	RDQS24	L20	PR28A	3	T	RDQS28
L21	PR14B	3	C		L21	PR23B	3	C		L21	PR27B	3	C	
GND	GND3	3			GND	GND3	3			GND	GND3	3		
M20	PR14A	3	T		M20	PR23A	3	T		M20	PR27A	3	T	
M18	PR13B	3	C		M18	PR22B	3	C		M18	PR26B	3	C	
M19	PR13A	3	T		M19	PR22A	3	T		M19	PR26A	3	T	
M22	PR12B	3	C		M22	PR21B	3	C		M22	PR25B	3	C	
L22	PR12A	3	T		L22	PR21A	3	T		L22	PR25A	3	T	
K22	PR11B	3	C		K22	PR20B	3	C		K22	PR24B	3	C	
K21	PR11A	3	T		K21	PR20A	3	T		K21	PR24A	3	T	
J22	PR9B	2	C	PCLKC2_0	J22	PR18B	2	C	PCLKC2_0	J22	PR22B	2	C	PCLKC2_0
GND	GND2	2			GND	GND2	2			GND	GND2	2		
J21	PR9A	2	T	PCLKT2_0	J21	PR18A	2	T	PCLKT2_0	J21	PR22A	2	T	PCLKT2_0
H22	PR8B	2	C		H22	PR17B	2	C		H22	PR21B	2	C	
H21	PR8A	2	T		H21	PR17A	2	T		H21	PR21A	2	T	
L19	PR7B	2	C		L19	PR16B	2	C		L19	PR20B	2	C	
L18	PR7A	2	T		L18	PR16A	2	T		L18	PR20A	2	T	
K20	PR6B	2	C		K20	PR15B	2	C		K20	PR19B	2	C	
J20	PR6A	2	T	RDQS6	J20	PR15A	2	T	RDQS15	J20	PR19A	2	T	RDQS19
K19	PR5B	2	C		K19	PR14B	2	C		K19	PR18B	2	C	
GND	-	-			GND	GND2	2			GND	GND2	2		
K18	PR5A	2	T		K18	PR14A	2	T		K18	PR18A	2	T	
G22	PR4B	2	C		G22	PR13B	2	C		G22	PR17B	2	C	
F22	PR4A	2	T		F22	PR13A	2	T		F22	PR17A	2	T	
F21	PR3B	2	C		F21	PR12B	2	C		F21	PR16B	2	C	
E22	PR3A	2	T		E22	PR12A	2	T		E22	PR16A	2	T	
E21	NC	-			E21	PR11B	2	C		E21	PR15B	2	C	
D22	NC	-			D22	PR11A	2	T		D22	PR15A	2	T	
G21	NC	-			G21	NC	-			G21	PR14B	2	C	
G20	NC	-			G20	NC	-			GND	GND2	2		
GND	-	-			-	-	-			G20	PR14A	2	T	
J18	NC	-			J18	NC	-			J18	PR13B	2	C	
H19	NC	-			H19	NC	-			H19	PR13A	2	T	
J19	NC	-			J19	NC	-			J19	PR12B	2	C	
H20	NC	-			H20	NC	-			H20	PR12A	2	T	
H17	NC	-			H17	NC	-			H17	PR11B	2	C	
H18	NC	-			H18	NC	-			H18	PR11A	2	T	
D21	NC	-			D21	PR9B	2	C	RUM0_PLLC_FB_A	D21	PR9B	2	C	RUM0_PLLC_FB_A
GND	-	-			GND	GND2	2			GND	GND2	2		
C22	NC	-			C22	PR9A	2	T	RUM0_PLLT_FB_A	C22	PR9A	2	T	RUM0_PLLT_FB_A
G19	NC	-			G19	PR8B	2	C	RUM0_PLLC_IN_A	G19	PR8B	2	C	RUM0_PLLC_IN_A
G18	NC	-			G18	PR8A	2	T	RUM0_PLLT_IN_A	G18	PR8A	2	T	RUM0_PLLT_IN_A
F20	NC	-			F20	PR7B	2	C		F20	PR7B	2	C	
F19	NC	-			F19	PR7A	2	T		F19	PR7A	2	T	
E20	NC	-			E20	PR6B	2	C		E20	PR6B	2	C	
D20	NC	-			D20	PR6A	2	T	RDQS6	D20	PR6A	2	T	RDQS6

**LFECP/EC6, LFECP/EC10, LFECP/EC15 Logic Signal Connections:  
484 fpBGA (Cont.)**

LFECP6/LFEC6					LFECP10/LFEC10					LFECP/LFEC15				
Ball Number	Ball Function	Bank	LVDS	Dual Function	Ball Number	Ball Function	Bank	LVDS	Dual Function	Ball Number	Ball Function	Bank	LVDS	Dual Function
C21	NC	-			C21	PR5B	2	C		C21	PR5B	2	C	
C20	NC	-			C20	PR5A	2	T		C20	PR5A	2	T	
F18	NC	-			F18	PR4B	2	C		F18	PR4B	2	C	
E18	NC	-			E18	PR4A	2	T		E18	PR4A	2	T	
B22	NC	-			B22	PR3B	2	C		B22	PR3B	2	C	
B21	NC	-			B21	PR3A	2	T		B21	PR3A	2	T	
E19	PR2B	2	C	VREF1_2	E19	PR2B	2	C	VREF1_2	E19	PR2B	2	C	VREF1_2
D19	PR2A	2	T	VREF2_2	D19	PR2A	2	T	VREF2_2	D19	PR2A	2	T	VREF2_2
GND	GND2	2			GND	GND2	2			GND	GND2	2		
GND	GND1	1			GND	GND1	1			GND	GND1	1		
G17	NC	-			G17	NC	-			G17	PT49B	1	C	
F17	NC	-			F17	NC	-			F17	PT49A	1	T	
D18	NC	-			D18	NC	-			D18	PT48B	1	C	
C18	NC	-			C18	NC	-			C18	PT48A	1	T	
C19	NC	-			C19	NC	-			C19	PT47B	1	C	
B20	NC	-			B20	NC	-			B20	PT47A	1	T	
D17	NC	-			D17	NC	-			D17	PT46B	1	C	
C16	NC	-			C16	NC	-			C16	PT46A	1	T	TDQS46
B19	NC	-			B19	NC	-			B19	PT45B	1	C	
GND	-	-			GND	-	-			GND	GND1	1		
A20	NC	-			A20	NC	-			A20	PT45A	1	T	
E17	NC	-			E17	NC	-			E17	PT44B	1	C	
C17	NC	-			C17	NC	-			C17	PT44A	1	T	
F16	NC	-			F16	NC	-			F16	PT43B	1	C	
E16	NC	-			E16	NC	-			E16	PT43A	1	T	
F15	NC	-			F15	NC	-			F15	PT42B	1	C	
D16	NC	-			D16	NC	-			D16	PT42A	1	T	
B18	PT33B	1	C		B18	PT41B	1	C		B18	PT41B	1	C	
GND	-	-			GND	-	-			GND	GND1	1		
A19	PT33A	1	T		A19	PT41A	1	T		A19	PT41A	1	T	
B17	PT32B	1	C		B17	PT40B	1	C		B17	PT40B	1	C	
A18	PT32A	1	T		A18	PT40A	1	T		A18	PT40A	1	T	
B16	PT31B	1	C		B16	PT39B	1	C		B16	PT39B	1	C	
A17	PT31A	1	T		A17	PT39A	1	T		A17	PT39A	1	T	
B15	PT30B	1	C		B15	PT38B	1	C		B15	PT38B	1	C	
A16	PT30A	1	T	TDQS30	A16	PT38A	1	T	TDQS38	A16	PT38A	1	T	TDQS38
A15	PT29B	1	C		A15	PT37B	1	C		A15	PT37B	1	C	
GND	GND1	1			GND	GND1	1			GND	GND1	1		
A14	PT29A	1	T		A14	PT37A	1	T		A14	PT37A	1	T	
G14	PT28B	1	C		G14	PT36B	1	C		G14	PT36B	1	C	
E15	PT28A	1	T		E15	PT36A	1	T		E15	PT36A	1	T	
D15	PT27B	1	C		D15	PT35B	1	C		D15	PT35B	1	C	
C15	PT27A	1	T		C15	PT35A	1	T		C15	PT35A	1	T	
C14	PT26B	1	C		C14	PT34B	1	C		C14	PT34B	1	C	
B14	PT26A	1	T		B14	PT34A	1	T		B14	PT34A	1	T	
A13	PT25B	1	C		A13	PT33B	1	C		A13	PT33B	1	C	
GND	GND1	1			GND	GND1	1			GND	GND1	1		
B13	PT25A	1	T		B13	PT33A	1	T		B13	PT33A	1	T	
E14	PT24B	1	C		E14	PT32B	1	C		E14	PT32B	1	C	
C13	PT24A	1	T		C13	PT32A	1	T		C13	PT32A	1	T	

**LFECP/EC6, LFECP/EC10, LFECP/EC15 Logic Signal Connections:  
484 fpBGA (Cont.)**

LFECP6/LFEC6					LFECP10/LFEC10					LFECP/LFEC15				
Ball Number	Ball Function	Bank	LVDS	Dual Function	Ball Number	Ball Function	Bank	LVDS	Dual Function	Ball Number	Ball Function	Bank	LVDS	Dual Function
F14	PT23B	1	C		F14	PT31B	1	C		F14	PT31B	1	C	
D14	PT23A	1	T		D14	PT31A	1	T		D14	PT31A	1	T	
E13	PT22B	1	C		E13	PT30B	1	C		E13	PT30B	1	C	
G13	PT22A	1	T	TDQS22	G13	PT30A	1	T	TDQS30	G13	PT30A	1	T	TDQS30
A12	PT21B	1	C		A12	PT29B	1	C		A12	PT29B	1	C	
GND	GND1	1			GND	GND1	1			GND	GND1	1		
B12	PT21A	1	T		B12	PT29A	1	T		B12	PT29A	1	T	
F13	PT20B	1	C		F13	PT28B	1	C		F13	PT28B	1	C	
D13	PT20A	1	T		D13	PT28A	1	T		D13	PT28A	1	T	
F12	PT19B	1	C	VREF2_1	F12	PT27B	1	C	VREF2_1	F12	PT27B	1	C	VREF2_1
D12	PT19A	1	T	VREF1_1	D12	PT27A	1	T	VREF1_1	D12	PT27A	1	T	VREF1_1
F11	PT18B	1	C		F11	PT26B	1	C		F11	PT26B	1	C	
C12	PT18A	1	T		C12	PT26A	1	T		C12	PT26A	1	T	
A11	PT17B	0	C	PCLKC0_0	A11	PT25B	0	C	PCLKC0_0	A11	PT25B	0	C	PCLKC0_0
GND	GND0	0			GND	GND0	0			GND	GND0	0		
A10	PT17A	0	T	PCLKT0_0	A10	PT25A	0	T	PCLKT0_0	A10	PT25A	0	T	PCLKT0_0
E12	PT16B	0	C	VREF1_0	E12	PT24B	0	C	VREF1_0	E12	PT24B	0	C	VREF1_0
E11	PT16A	0	T	VREF2_0	E11	PT24A	0	T	VREF2_0	E11	PT24A	0	T	VREF2_0
B11	PT15B	0	C		B11	PT23B	0	C		B11	PT23B	0	C	
C11	PT15A	0	T		C11	PT23A	0	T		C11	PT23A	0	T	
B9	PT14B	0	C		B9	PT22B	0	C		B9	PT22B	0	C	
B10	PT14A	0	T	TDQS14	B10	PT22A	0	T	TDQS22	B10	PT22A	0	T	TDQS22
A9	PT13B	0	C		A9	PT21B	0	C		A9	PT21B	0	C	
GND	GND0	0			GND	GND0	0			GND	GND0	0		
A8	PT13A	0	T		A8	PT21A	0	T		A8	PT21A	0	T	
D11	PT12B	0	C		D11	PT20B	0	C		D11	PT20B	0	C	
C10	PT12A	0	T		C10	PT20A	0	T		C10	PT20A	0	T	
A7	PT11B	0	C		A7	PT19B	0	C		A7	PT19B	0	C	
A6	PT11A	0	T		A6	PT19A	0	T		A6	PT19A	0	T	
B7	PT10B	0	C		B7	PT18B	0	C		B7	PT18B	0	C	
B8	PT10A	0	T		B8	PT18A	0	T		B8	PT18A	0	T	
A5	PT9B	0	C		A5	PT17B	0	C		A5	PT17B	0	C	
GND	GND0	0			GND	GND0	0			GND	GND0	0		
B6	PT9A	0	T		B6	PT17A	0	T		B6	PT17A	0	T	
G10	PT8B	0	C		G10	PT16B	0	C		G10	PT16B	0	C	
E10	PT8A	0	T		E10	PT16A	0	T		E10	PT16A	0	T	
F10	PT7B	0	C		F10	PT15B	0	C		F10	PT15B	0	C	
D10	PT7A	0	T		D10	PT15A	0	T		D10	PT15A	0	T	
G9	PT6B	0	C		G9	PT14B	0	C		G9	PT14B	0	C	
E9	PT6A	0	T	TDQS6	E9	PT14A	0	T	TDQS14	E9	PT14A	0	T	TDQS14
C9	PT5B	0	C		C9	PT13B	0	C		C9	PT13B	0	C	
GND	-	-			GND	GND0	0			GND	GND0	0		
C8	PT5A	0	T		C8	PT13A	0	T		C8	PT13A	0	T	
F9	PT4B	0	C		F9	PT12B	0	C		F9	PT12B	0	C	
D9	PT4A	0	T		D9	PT12A	0	T		D9	PT12A	0	T	
F8	PT3B	0	C		F8	PT11B	0	C		F8	PT11B	0	C	
D7	PT3A	0	T		D7	PT11A	0	T		D7	PT11A	0	T	
D8	PT2B	0	C		D8	PT10B	0	C		D8	PT10B	0	C	
C7	PT2A	0	T		C7	PT10A	0	T		C7	PT10A	0	T	
GND	GND0	0			GND	GND0	0			GND	GND0	0		

**LFECP/EC6, LFECP/EC10, LFECP/EC15 Logic Signal Connections:  
484 fpBGA (Cont.)**

LFECP6/LFEC6					LFECP10/LFEC10					LFECP/LFEC15				
Ball Number	Ball Function	Bank	LVDS	Dual Function	Ball Number	Ball Function	Bank	LVDS	Dual Function	Ball Number	Ball Function	Bank	LVDS	Dual Function
A4	NC	-			A4	PT9B	0	C		A4	PT9B	0	C	
B4	NC	-			B4	PT9A	0	T		B4	PT9A	0	T	
C4	NC	-			C4	PT8B	0	C		C4	PT8B	0	C	
C5	NC	-			C5	PT8A	0	T		C5	PT8A	0	T	
D6	NC	-			D6	PT7B	0	C		D6	PT7B	0	C	
B5	NC	-			B5	PT7A	0	T		B5	PT7A	0	T	
E6	NC	-			E6	PT6B	0	C		E6	PT6B	0	C	
C6	NC	-			C6	PT6A	0	T	TDQS6	C6	PT6A	0	T	TDQS6
A3	NC	-			A3	PT5B	0	C		A3	PT5B	0	C	
B3	NC	-			B3	PT5A	0	T		B3	PT5A	0	T	
F6	NC	-			F6	PT4B	0	C		F6	PT4B	0	C	
D5	NC	-			D5	PT4A	0	T		D5	PT4A	0	T	
F7	NC	-			F7	PT3B	0	C		F7	PT3B	0	C	
E8	NC	-			E8	PT3A	0	T		E8	PT3A	0	T	
G6	NC	-			G6	PT2B	0	C		G6	PT2B	0	C	
E7	NC	-			E7	PT2A	0	T		E7	PT2A	0	T	
GND	-	-			GND	GND0	0			GND	GND0	0		
A1	GND	-			A1	GND	-			A1	GND	-		
A22	GND	-			A22	GND	-			A22	GND	-		
AB1	GND	-			AB1	GND	-			AB1	GND	-		
AB22	GND	-			AB22	GND	-			AB22	GND	-		
H15	GND	-			H15	GND	-			H15	GND	-		
H8	GND	-			H8	GND	-			H8	GND	-		
J10	GND	-			J10	GND	-			J10	GND	-		
J11	GND	-			J11	GND	-			J11	GND	-		
J12	GND	-			J12	GND	-			J12	GND	-		
J13	GND	-			J13	GND	-			J13	GND	-		
J14	GND	-			J14	GND	-			J14	GND	-		
J9	GND	-			J9	GND	-			J9	GND	-		
K10	GND	-			K10	GND	-			K10	GND	-		
K11	GND	-			K11	GND	-			K11	GND	-		
K12	GND	-			K12	GND	-			K12	GND	-		
K13	GND	-			K13	GND	-			K13	GND	-		
K14	GND	-			K14	GND	-			K14	GND	-		
K9	GND	-			K9	GND	-			K9	GND	-		
L10	GND	-			L10	GND	-			L10	GND	-		
L11	GND	-			L11	GND	-			L11	GND	-		
L12	GND	-			L12	GND	-			L12	GND	-		
L13	GND	-			L13	GND	-			L13	GND	-		
L14	GND	-			L14	GND	-			L14	GND	-		
L9	GND	-			L9	GND	-			L9	GND	-		
M10	GND	-			M10	GND	-			M10	GND	-		
M11	GND	-			M11	GND	-			M11	GND	-		
M12	GND	-			M12	GND	-			M12	GND	-		
M13	GND	-			M13	GND	-			M13	GND	-		
M14	GND	-			M14	GND	-			M14	GND	-		
M9	GND	-			M9	GND	-			M9	GND	-		
N10	GND	-			N10	GND	-			N10	GND	-		
N11	GND	-			N11	GND	-			N11	GND	-		
N12	GND	-			N12	GND	-			N12	GND	-		



**LFECP/EC6, LFECP/EC10, LFECP/EC15 Logic Signal Connections:  
484 fpBGA (Cont.)**

LFECP6/LFEC6					LFECP10/LFEC10					LFECP/LFEC15				
Ball Number	Ball Function	Bank	LVDS	Dual Function	Ball Number	Ball Function	Bank	LVDS	Dual Function	Ball Number	Ball Function	Bank	LVDS	Dual Function
N13	GND	-			N13	GND	-			N13	GND	-		
N14	GND	-			N14	GND	-			N14	GND	-		
N9	GND	-			N9	GND	-			N9	GND	-		
P10	GND	-			P10	GND	-			P10	GND	-		
P11	GND	-			P11	GND	-			P11	GND	-		
P12	GND	-			P12	GND	-			P12	GND	-		
P13	GND	-			P13	GND	-			P13	GND	-		
P14	GND	-			P14	GND	-			P14	GND	-		
P9	GND	-			P9	GND	-			P9	GND	-		
R15	GND	-			R15	GND	-			R15	GND	-		
R8	GND	-			R8	GND	-			R8	GND	-		
J16	VCC	-			J16	VCC	-			J16	VCC	-		
J7	VCC	-			J7	VCC	-			J7	VCC	-		
K16	VCC	-			K16	VCC	-			K16	VCC	-		
K17	VCC	-			K17	VCC	-			K17	VCC	-		
K6	VCC	-			K6	VCC	-			K6	VCC	-		
K7	VCC	-			K7	VCC	-			K7	VCC	-		
L17	VCC	-			L17	VCC	-			L17	VCC	-		
L6	VCC	-			L6	VCC	-			L6	VCC	-		
M17	VCC	-			M17	VCC	-			M17	VCC	-		
M6	VCC	-			M6	VCC	-			M6	VCC	-		
N16	VCC	-			N16	VCC	-			N16	VCC	-		
N17	VCC	-			N17	VCC	-			N17	VCC	-		
N6	VCC	-			N6	VCC	-			N6	VCC	-		
N7	VCC	-			N7	VCC	-			N7	VCC	-		
P16	VCC	-			P16	VCC	-			P16	VCC	-		
P7	VCC	-			P7	VCC	-			P7	VCC	-		
G11	VCCIO0	0			G11	VCCIO0	0			G11	VCCIO0	0		
H10	VCCIO0	0			H10	VCCIO0	0			H10	VCCIO0	0		
H11	VCCIO0	0			H11	VCCIO0	0			H11	VCCIO0	0		
H9	VCCIO0	0			H9	VCCIO0	0			H9	VCCIO0	0		
G12	VCCIO1	1			G12	VCCIO1	1			G12	VCCIO1	1		
H12	VCCIO1	1			H12	VCCIO1	1			H12	VCCIO1	1		
H13	VCCIO1	1			H13	VCCIO1	1			H13	VCCIO1	1		
H14	VCCIO1	1			H14	VCCIO1	1			H14	VCCIO1	1		
J15	VCCIO2	2			J15	VCCIO2	2			J15	VCCIO2	2		
K15	VCCIO2	2			K15	VCCIO2	2			K15	VCCIO2	2		
L15	VCCIO2	2			L15	VCCIO2	2			L15	VCCIO2	2		
L16	VCCIO2	2			L16	VCCIO2	2			L16	VCCIO2	2		
M15	VCCIO3	3			M15	VCCIO3	3			M15	VCCIO3	3		
M16	VCCIO3	3			M16	VCCIO3	3			M16	VCCIO3	3		
N15	VCCIO3	3			N15	VCCIO3	3			N15	VCCIO3	3		
P15	VCCIO3	3			P15	VCCIO3	3			P15	VCCIO3	3		
R12	VCCIO4	4			R12	VCCIO4	4			R12	VCCIO4	4		
R13	VCCIO4	4			R13	VCCIO4	4			R13	VCCIO4	4		
R14	VCCIO4	4			R14	VCCIO4	4			R14	VCCIO4	4		
T12	VCCIO4	4			T12	VCCIO4	4			T12	VCCIO4	4		
R10	VCCIO5	5			R10	VCCIO5	5			R10	VCCIO5	5		
R11	VCCIO5	5			R11	VCCIO5	5			R11	VCCIO5	5		
R9	VCCIO5	5			R9	VCCIO5	5			R9	VCCIO5	5		

**LFECP/EC6, LFECP/EC10, LFECP/EC15 Logic Signal Connections:  
484 fpBGA (Cont.)**

LFECP6/LFEC6					LFECP10/LFEC10					LFECP/LFEC15				
Ball Number	Ball Function	Bank	LVDS	Dual Function	Ball Number	Ball Function	Bank	LVDS	Dual Function	Ball Number	Ball Function	Bank	LVDS	Dual Function
T11	VCCIO5	5			T11	VCCIO5	5			T11	VCCIO5	5		
M7	VCCIO6	6			M7	VCCIO6	6			M7	VCCIO6	6		
M8	VCCIO6	6			M8	VCCIO6	6			M8	VCCIO6	6		
N8	VCCIO6	6			N8	VCCIO6	6			N8	VCCIO6	6		
P8	VCCIO6	6			P8	VCCIO6	6			P8	VCCIO6	6		
J8	VCCIO7	7			J8	VCCIO7	7			J8	VCCIO7	7		
K8	VCCIO7	7			K8	VCCIO7	7			K8	VCCIO7	7		
L7	VCCIO7	7			L7	VCCIO7	7			L7	VCCIO7	7		
L8	VCCIO7	7			L8	VCCIO7	7			L8	VCCIO7	7		
G15	VCCAUX	-			G15	VCCAUX	-			G15	VCCAUX	-		
G16	VCCAUX	-			G16	VCCAUX	-			G16	VCCAUX	-		
G7	VCCAUX	-			G7	VCCAUX	-			G7	VCCAUX	-		
G8	VCCAUX	-			G8	VCCAUX	-			G8	VCCAUX	-		
H16	VCCAUX	-			H16	VCCAUX	-			H16	VCCAUX	-		
H7	VCCAUX	-			H7	VCCAUX	-			H7	VCCAUX	-		
R16	VCCAUX	-			R16	VCCAUX	-			R16	VCCAUX	-		
R7	VCCAUX	-			R7	VCCAUX	-			R7	VCCAUX	-		
T15	VCCAUX	-			T15	VCCAUX	-			T15	VCCAUX	-		
T16	VCCAUX	-			T16	VCCAUX	-			T16	VCCAUX	-		
T7	VCCAUX	-			T7	VCCAUX	-			T7	VCCAUX	-		
T8	VCCAUX	-			T8	VCCAUX	-			T8	VCCAUX	-		
J6	VCC	-			J6	VCC	-			J6	VCC	-		
J17	VCC	-			J17	VCC	-			J17	VCC	-		
P6	VCC	-			P6	VCC	-			P6	VCC	-		
P17	VCC	-			P17	VCC	-			P17	VCC	-		
A2	NC	-			A2	NC	-			A2	NC	-		
AB2	NC	-			AB2	NC	-			AB2	NC	-		
A21	NC	-			A21	NC	-			A21	NC	-		

**LFECP/EC20 and LFECP/EC33 Logic Signal Connections: 484 fpBGA**

LFECP20/LFEC20					LFECP/LFEC33				
Ball Number	Ball Function	Bank	LVDS	Dual Function	Ball Number	Ball Function	Bank	LVDS	Dual Function
GND	GND7	7			GND	GND7	7		
D4	PL2A	7	T	VREF2_7	D4	PL2A	7	T	VREF2_7
E4	PL2B	7	C	VREF1_7	E4	PL2B	7	C	VREF1_7
GND	-	-			GND	GND7	7		
C3	PL3A	7	T		C3	PL10A	7	T	
B2	PL3B	7	C		B2	PL10B	7	C	
E5	PL4A	7	T		E5	PL11A	7	T	
F5	PL4B	7	C		F5	PL11B	7	C	
D3	PL5A	7	T		D3	PL12A	7	T	
C2	PL5B	7	C		C2	PL12B	7	C	
GND	-	-			GND	GND7	7		
F4	PL6A	7	T	LDQS6	F4	PL14A	7	T	LDQS14
G4	PL6B	7	C		G4	PL14B	7	C	
E3	PL7A	7	T		E3	PL15A	7	T	
D2	PL7B	7	C		D2	PL15B	7	C	
B1	PL8A	7	T	LUM0_PLLT_IN_A	B1	PL16A	7	T	LUM0_PLLT_IN_A
C1	PL8B	7	C	LUM0_PLLC_IN_A	C1	PL16B	7	C	LUM0_PLLC_IN_A
F3	PL9A	7	T	LUM0_PLLT_FB_A	F3	PL17A	7	T	LUM0_PLLT_FB_A
GND	GND7	7			GND	GND7	7		
E2	PL9B	7	C	LUM0_PLLC_FB_A	E2	PL17B	7	C	LUM0_PLLC_FB_A
GND	-	-			GND	GND7	7		
G5	PL11A	7	T		G5	PL23A	7	T	LDQS23
H6	PL11B	7	C		H6	PL23B	7	C	
G3	PL12A	7	T		G3	PL24A	7	T	
H4	PL12B	7	C		H4	PL24B	7	C	
J5	PL13A	7	T		J5	PL25A	7	T	
H5	PL13B	7	C		H5	PL25B	7	C	
F2	PL14A	7	T		F2	PL26A	7	T	
GND	GND7	7			GND	GND7	7		
F1	PL14B	7	C		F1	PL26B	7	C	
E1	PL15A	7	T		E1	PL27A	7	T	
D1	PL15B	7	C		D1	PL27B	7	C	
H3	PL16A	7	T		H3	PL28A	7	T	
G2	PL16B	7	C		G2	PL28B	7	C	
H2	PL17A	7	T		H2	PL29A	7	T	
G1	PL17B	7	C		G1	PL29B	7	C	
J4	PL18A	7	T		J4	PL30A	7	T	
GND	GND7	7			GND	GND7	7		
J3	PL18B	7	C		J3	PL30B	7	C	
J2	PL19A	7	T	LDQS19	J2	PL31A	7	T	LDQS31
H1	PL19B	7	C		H1	PL31B	7	C	
K4	PL20A	7	T		K4	PL32A	7	T	
K5	PL20B	7	C		K5	PL32B	7	C	
K3	PL21A	7	T		K3	PL33A	7	T	

**LFECP/EC20 and LFECP/EC33 Logic Signal Connections: 484 fpBGA**

LFECP20/LFEC20					LFECP/LFEC33				
Ball Number	Ball Function	Bank	LVDS	Dual Function	Ball Number	Ball Function	Bank	LVDS	Dual Function
K2	PL21B	7	C		K2	PL33B	7	C	
J1	PL22A	7	T	PCLKT7_0	J1	PL34A	7	T	PCLKT7_0
GND	GND7	7			GND	GND7	7		
K1	PL22B	7	C	PCLKC7_0	K1	PL34B	7	C	PCLKC7_0
L3	XRES	6			L3	XRES	6		
L4	PL24A	6	T		L4	PL36A	6	T	
L5	PL24B	6	C		L5	PL36B	6	C	
L2	PL25A	6	T		L2	PL37A	6	T	
L1	PL25B	6	C		L1	PL37B	6	C	
M4	PL26A	6	T		M4	PL38A	6	T	
M5	PL26B	6	C		M5	PL38B	6	C	
M1	PL27A	6	T		M1	PL39A	6	T	
GND	GND6	6			GND	GND6	6		
M2	PL27B	6	C		M2	PL39B	6	C	
N3	PL28A	6	T	LDQS28	N3	PL40A	6	T	LDQS40
M3	PL28B	6	C		M3	PL40B	6	C	
N5	PL29A	6	T		N5	PL41A	6	T	
N4	PL29B	6	C		N4	PL41B	6	C	
N1	PL30A	6	T		N1	PL42A	6	T	
N2	PL30B	6	C		N2	PL42B	6	C	
P1	PL31A	6	T		P1	PL43A	6	T	
GND	GND6	6			GND	GND6	6		
P2	PL31B	6	C		P2	PL43B	6	C	
R6	PL32A	6	T		R6	PL44A	6	T	
P5	PL32B	6	C		P5	PL44B	6	C	
P3	PL33A	6	T		P3	PL45A	6	T	
P4	PL33B	6	C		P4	PL45B	6	C	
R1	PL34A	6	T		R1	PL46A	6	T	
R2	PL34B	6	C		R2	PL46B	6	C	
R5	PL35A	6	T		R5	PL47A	6	T	
GND	GND6	6			GND	GND6	6		
R4	PL35B	6	C		R4	PL47B	6	C	
T1	PL36A	6	T	LDQS36	T1	PL48A	6	T	LDQS48
T2	PL36B	6	C		T2	PL48B	6	C	
R3	PL37A	6	T		R3	PL49A	6	T	
T3	PL37B	6	C		T3	PL49B	6	C	
GND	GND6	6			GND	GND6	6		
T5	TCK	6			T5	TCK	6		
U5	TDI	6			U5	TDI	6		
T4	TMS	6			T4	TMS	6		
U1	TDO	6			U1	TDO	6		
U2	VCCJ	6			U2	VCCJ	6		
V1	PL41A	6	T	LLM0_PLLT_IN_A	V1	PL53A	6	T	LLM0_PLLT_IN_A
V2	PL41B	6	C	LLM0_PLLC_IN_A	V2	PL53B	6	C	LLM0_PLLC_IN_A

**LFECP/EC20 and LFECP/EC33 Logic Signal Connections: 484 fpBGA**

LFECP20/LFEC20					LFECP/LFEC33				
Ball Number	Ball Function	Bank	LVDS	Dual Function	Ball Number	Ball Function	Bank	LVDS	Dual Function
U3	PL42A	6	T	LLM0_PLLT_FB_A	U3	PL54A	6	T	LLM0_PLLT_FB_A
V3	PL42B	6	C	LLM0_PLLC_FB_A	V3	PL54B	6	C	LLM0_PLLC_FB_A
U4	PL43A	6	T		U4	PL55A	6	T	
V5	PL43B	6	C		V5	PL55B	6	C	
W1	PL44A	6	T		W1	PL56A	6	T	
GND	GND6	6			GND	GND6	6		
W2	PL44B	6	C		W2	PL56B	6	C	
Y1	PL45A	6	T	LDQS45	Y1	PL57A	6	T	LDQS57
Y2	PL45B	6	C		Y2	PL57B	6	C	
AA1	PL46A	6	T		AA1	PL58A	6	T	
AA2	PL46B	6	C		AA2	PL58B	6	C	
W4	PL47A	6	T		W4	PL59A	6	T	
V4	PL47B	6	C		V4	PL59B	6	C	
W3	PL48A	6	T	VREF1_6	W3	PL68A	6	T	VREF1_6
Y3	PL48B	6	C	VREF2_6	Y3	PL68B	6	C	VREF2_6
GND	GND6	6			GND	GND6	6		
GND	GND5	5			GND	GND6	6		
GND	-				GND	GND6	6		
GND	-				GND	GND5	5		
GND	GND5	5			GND	GND5	5		
V7	PB10A	5	T		V7	PB10A	5	T	
T6	PB10B	5	C		T6	PB10B	5	C	
V8	PB11A	5	T		V8	PB11A	5	T	
U7	PB11B	5	C		U7	PB11B	5	C	
W5	PB12A	5	T		W5	PB12A	5	T	
U6	PB12B	5	C		U6	PB12B	5	C	
AA3	PB13A	5	T		AA3	PB13A	5	T	
GND	GND5	5			GND	GND5	5		
AB3	PB13B	5	C		AB3	PB13B	5	C	
Y6	PB14A	5	T	BDQS14	Y6	PB14A	5	T	BDQS14
V6	PB14B	5	C		V6	PB14B	5	C	
AA5	PB15A	5	T		AA5	PB15A	5	T	
W6	PB15B	5	C		W6	PB15B	5	C	
Y5	PB16A	5	T		Y5	PB16A	5	T	
Y4	PB16B	5	C		Y4	PB16B	5	C	
AA4	PB17A	5	T		AA4	PB17A	5	T	
GND	GND5	5			GND	GND5	5		
AB4	PB17B	5	C		AB4	PB17B	5	C	
Y7	PB18A	5	T		Y7	PB18A	5	T	
W8	PB18B	5	C		W8	PB18B	5	C	
W7	PB19A	5	T		W7	PB19A	5	T	
U8	PB19B	5	C		U8	PB19B	5	C	
W9	PB20A	5	T		W9	PB20A	5	T	
U9	PB20B	5	C		U9	PB20B	5	C	

**LFECP/EC20 and LFECP/EC33 Logic Signal Connections: 484 fpBGA**

LFECP20/LFEC20					LFECP/LFEC33				
Ball Number	Ball Function	Bank	LVDS	Dual Function	Ball Number	Ball Function	Bank	LVDS	Dual Function
Y8	PB21A	5	T		Y8	PB21A	5	T	
GND	GND5	5			GND	GND5	5		
Y9	PB21B	5	C		Y9	PB21B	5	C	
V9	PB22A	5	T	BDQS22	V9	PB22A	5	T	BDQS22
T9	PB22B	5	C		T9	PB22B	5	C	
W10	PB23A	5	T		W10	PB23A	5	T	
U10	PB23B	5	C		U10	PB23B	5	C	
V10	PB24A	5	T		V10	PB24A	5	T	
T10	PB24B	5	C		T10	PB24B	5	C	
AA6	PB25A	5	T		AA6	PB25A	5	T	
GND	GND5	5			GND	GND5	5		
AB5	PB25B	5	C		AB5	PB25B	5	C	
AA8	PB26A	5	T		AA8	PB26A	5	T	
AA7	PB26B	5	C		AA7	PB26B	5	C	
AB6	PB27A	5	T		AB6	PB27A	5	T	
AB7	PB27B	5	C		AB7	PB27B	5	C	
Y10	PB28A	5	T		Y10	PB28A	5	T	
W11	PB28B	5	C		W11	PB28B	5	C	
AB8	PB29A	5	T		AB8	PB29A	5	T	
GND	GND5	5			GND	GND5	5		
AB9	PB29B	5	C		AB9	PB29B	5	C	
AA10	PB30A	5	T	BDQS30	AA10	PB30A	5	T	BDQS30
AA9	PB30B	5	C		AA9	PB30B	5	C	
Y11	PB31A	5	T		Y11	PB31A	5	T	
AA11	PB31B	5	C		AA11	PB31B	5	C	
V11	PB32A	5	T	VREF2_5	V11	PB32A	5	T	VREF2_5
V12	PB32B	5	C	VREF1_5	V12	PB32B	5	C	VREF1_5
AB10	PB33A	5	T	PCLKT5_0	AB10	PB33A	5	T	PCLKT5_0
GND	GND5	5			GND	GND5	5		
AB11	PB33B	5	C	PCLKC5_0	AB11	PB33B	5	C	PCLKC5_0
Y12	PB34A	4	T	WRITEN	Y12	PB34A	4	T	WRITEN
U11	PB34B	4	C	CS1N	U11	PB34B	4	C	CS1N
W12	PB35A	4	T	VREF1_4	W12	PB35A	4	T	VREF1_4
U12	PB35B	4	C	CSN	U12	PB35B	4	C	CSN
W13	PB36A	4	T	VREF2_4	W13	PB36A	4	T	VREF2_4
U13	PB36B	4	C	D0/SPID7	U13	PB36B	4	C	D0/SPID7
AA12	PB37A	4	T	D2/SPID5	AA12	PB37A	4	T	D2/SPID5
GND	GND4	4			GND	GND4	4		
AB12	PB37B	4	C	D1/SPID6	AB12	PB37B	4	C	D1/SPID6
T13	PB38A	4	T	BDQS38	T13	PB38A	4	T	BDQS38
V13	PB38B	4	C	D3/SPID4	V13	PB38B	4	C	D3/SPID4
W14	PB39A	4	T		W14	PB39A	4	T	
U14	PB39B	4	C	D4/SPID3	U14	PB39B	4	C	D4/SPID3
Y13	PB40A	4	T		Y13	PB40A	4	T	

**LFECP/EC20 and LFECP/EC33 Logic Signal Connections: 484 fpBGA**

LFECP20/LFEC20					LFECP/LFEC33				
Ball Number	Ball Function	Bank	LVDS	Dual Function	Ball Number	Ball Function	Bank	LVDS	Dual Function
V14	PB40B	4	C	D5/SPID2	V14	PB40B	4	C	D5/SPID2
AA13	PB41A	4	T		AA13	PB41A	4	T	
GND	GND4	4			GND	GND4	4		
AB13	PB41B	4	C	D6/SPID1	AB13	PB41B	4	C	D6/SPID1
AA14	PB42A	4	T		AA14	PB42A	4	T	
Y14	PB42B	4	C		Y14	PB42B	4	C	
Y15	PB43A	4	T		Y15	PB43A	4	T	
W15	PB43B	4	C		W15	PB43B	4	C	
V15	PB44A	4	T		V15	PB44A	4	T	
T14	PB44B	4	C		T14	PB44B	4	C	
AB14	PB45A	4	T		AB14	PB45A	4	T	
GND	GND4	4			GND	GND4	4		
AB15	PB45B	4	C		AB15	PB45B	4	C	
AB16	PB46A	4	T	BDQS46	AB16	PB46A	4	T	BDQS46
AA15	PB46B	4	C		AA15	PB46B	4	C	
AB17	PB47A	4	T		AB17	PB47A	4	T	
AA16	PB47B	4	C		AA16	PB47B	4	C	
AB18	PB48A	4	T		AB18	PB48A	4	T	
AA17	PB48B	4	C		AA17	PB48B	4	C	
AB19	PB49A	4	T		AB19	PB49A	4	T	
GND	GND4	4			GND	GND4	4		
AA18	PB49B	4	C		AA18	PB49B	4	C	
W16	PB50A	4	T		W16	PB50A	4	T	
U15	PB50B	4	C		U15	PB50B	4	C	
V16	PB51A	4	T		V16	PB51A	4	T	
U16	PB51B	4	C		U16	PB51B	4	C	
Y17	PB52A	4	T		Y17	PB52A	4	T	
V17	PB52B	4	C		V17	PB52B	4	C	
AB20	PB53A	4	T		AB20	PB53A	4	T	
GND	GND4	4			GND	GND4	4		
AA19	PB53B	4	C		AA19	PB53B	4	C	
Y16	PB54A	4	T	BDQS54	Y16	PB54A	4	T	BDQS54
W17	PB54B	4	C		W17	PB54B	4	C	
AA20	PB55A	4	T		AA20	PB55A	4	T	
Y19	PB55B	4	C		Y19	PB55B	4	C	
Y18	PB56A	4	T		Y18	PB56A	4	T	
W18	PB56B	4	C		W18	PB56B	4	C	
T17	PB57A	4	T		T17	PB57A	4	T	
U17	PB57B	4	C		U17	PB57B	4	C	
GND	-	-			GND	GND4	4		
GND	GND4	4			GND	GND4	4		
GND	GND3	3			GND	GND4	4		
GND	-	-			GND	GND3	3		
W20	PR48B	3	C	VREF2_3	W20	PR68B	3	C	VREF2_3

**LFECP/EC20 and LFECP/EC33 Logic Signal Connections: 484 fpBGA**

LFECP20/LFEC20					LFECP/LFEC33				
Ball Number	Ball Function	Bank	LVDS	Dual Function	Ball Number	Ball Function	Bank	LVDS	Dual Function
Y20	PR48A	3	T	VREF1_3	Y20	PR68A	3	T	VREF1_3
GND	-	-			GND	GND3	3		
GND	-	-			GND	GND3	3		
AA21	PR47B	3	C		AA21	PR59B	3	C	
AB21	PR47A	3	T		AB21	PR59A	3	T	
W19	PR46B	3	C		W19	PR58B	3	C	
V19	PR46A	3	T		V19	PR58A	3	T	
Y21	PR45B	3	C		Y21	PR57B	3	C	
AA22	PR45A	3	T	RDQS45	AA22	PR57A	3	T	RDQS57
V20	PR44B	3	C	RLM0_PLLC_IN_A	V20	PR56B	3	C	RLM0_PLLC_IN_A
GND	GND3	3			GND	GND3	3		
U20	PR44A	3	T	RLM0_PLLT_IN_A	U20	PR56A	3	T	RLM0_PLLT_IN_A
W21	PR43B	3	C	RLM0_PLLC_FB_A	W21	PR55B	3	C	RLM0_PLLC_FB_A
Y22	PR43A	3	T	RLM0_PLLT_FB_A	Y22	PR55A	3	T	RLM0_PLLT_FB_A
V21	PR42B	3	C	DI/CSSPIN	V21	PR54B	3	C	DI/CSSPIN
W22	PR42A	3	T	DOUT/CSON	W22	PR54A	3	T	DOUT/CSON
U21	PR41B	3	C	BUSY/SISPI	U21	PR53B	3	C	BUSY/SISPI
V22	PR41A	3	T	D7/SPID0	V22	PR53A	3	T	D7/SPID0
T19	CFG2	3			T19	CFG2	3		
U19	CFG1	3			U19	CFG1	3		
U18	CFG0	3			U18	CFG0	3		
V18	PROGRAMN	3			V18	PROGRAMN	3		
T20	CCLK	3			T20	CCLK	3		
T21	INITN	3			T21	INITN	3		
R20	DONE	3			R20	DONE	3		
GND	GND3	3			GND	GND3	3		
T18	PR37B	3	C		T18	PR49B	3	C	
R17	PR37A	3	T		R17	PR49A	3	T	
R19	PR36B	3	C		R19	PR48B	3	C	
R18	PR36A	3	T	RDQS36	R18	PR48A	3	T	RDQS48
U22	PR35B	3	C		U22	PR47B	3	C	
GND	GND3	3			GND	GND3	3		
T22	PR35A	3	T		T22	PR47A	3	T	
R21	PR34B	3	C		R21	PR46B	3	C	
R22	PR34A	3	T		R22	PR46A	3	T	
P20	PR33B	3	C		P20	PR45B	3	C	
N20	PR33A	3	T		N20	PR45A	3	T	
P19	PR32B	3	C		P19	PR44B	3	C	
P18	PR32A	3	T		P18	PR44A	3	T	
P21	PR31B	3	C		P21	PR43B	3	C	
GND	GND3	3			GND	GND3	3		
P22	PR31A	3	T		P22	PR43A	3	T	
N21	PR30B	3	C		N21	PR42B	3	C	
N22	PR30A	3	T		N22	PR42A	3	T	



**LFECP/EC20 and LFECP/EC33 Logic Signal Connections: 484 fpBGA**

LFECP20/LFEC20					LFECP/LFEC33				
Ball Number	Ball Function	Bank	LVDS	Dual Function	Ball Number	Ball Function	Bank	LVDS	Dual Function
N19	PR29B	3	C		N19	PR41B	3	C	
N18	PR29A	3	T		N18	PR41A	3	T	
M21	PR28B	3	C		M21	PR40B	3	C	
L20	PR28A	3	T	RDQS28	L20	PR40A	3	T	RDQS40
L21	PR27B	3	C		L21	PR39B	3	C	
GND	GND3	3			GND	GND3	3		
M20	PR27A	3	T		M20	PR39A	3	T	
M18	PR26B	3	C		M18	PR38B	3	C	
M19	PR26A	3	T		M19	PR38A	3	T	
M22	PR25B	3	C		M22	PR37B	3	C	
L22	PR25A	3	T		L22	PR37A	3	T	
K22	PR24B	3	C		K22	PR36B	3	C	
K21	PR24A	3	T		K21	PR36A	3	T	
J22	PR22B	2	C	PCLKC2_0	J22	PR34B	2	C	PCLKC2_0
GND	GND2	2			GND	GND2	2		
J21	PR22A	2	T	PCLKT2_0	J21	PR34A	2	T	PCLKT2_0
H22	PR21B	2	C		H22	PR33B	2	C	
H21	PR21A	2	T		H21	PR33A	2	T	
L19	PR20B	2	C		L19	PR32B	2	C	
L18	PR20A	2	T		L18	PR32A	2	T	
K20	PR19B	2	C		K20	PR31B	2	C	
J20	PR19A	2	T	RDQS19	J20	PR31A	2	T	RDQS31
K19	PR18B	2	C		K19	PR30B	2	C	
GND	GND2	2			GND	GND2	2		
K18	PR18A	2	T		K18	PR30A	2	T	
G22	PR17B	2	C		G22	PR29B	2	C	
F22	PR17A	2	T		F22	PR29A	2	T	
F21	PR16B	2	C		F21	PR28B	2	C	
E22	PR16A	2	T		E22	PR28A	2	T	
E21	PR15B	2	C		E21	PR27B	2	C	
D22	PR15A	2	T		D22	PR27A	2	T	
G21	PR14B	2	C		G21	PR26B	2	C	
G20	PR14A	2	T		G20	PR26A	2	T	
GND	GND2	2			GND	GND2	2		
J18	PR13B	2	C		J18	PR25B	2	C	
H19	PR13A	2	T		H19	PR25A	2	T	
J19	PR12B	2	C		J19	PR24B	2	C	
H20	PR12A	2	T		H20	PR24A	2	T	
H17	PR11B	2	C		H17	PR23B	2	C	
H18	PR11A	2	T		H18	PR23A	2	T	RDQS23
D21	PR9B	2	C	RUM0_PLLC_FB_A	D21	PR17B	2	C	RUM0_PLLC_FB_A
GND	GND2	2			GND	GND2	2		
GND	-	-			GND	GND2	2		
C22	PR9A	2	T	RUM0_PLLT_FB_A	C22	PR17A	2	T	RUM0_PLLT_FB_A

**LFECP/EC20 and LFECP/EC33 Logic Signal Connections: 484 fpBGA**

LFECP20/LFEC20					LFECP/LFEC33				
Ball Number	Ball Function	Bank	LVDS	Dual Function	Ball Number	Ball Function	Bank	LVDS	Dual Function
G19	PR8B	2	C	RUM0_PLLC_IN_A	G19	PR16B	2	C	RUM0_PLLC_IN_A
G18	PR8A	2	T	RUM0_PLLT_IN_A	G18	PR16A	2	T	RUM0_PLLT_IN_A
F20	PR7B	2	C		F20	PR15B	2	C	
F19	PR7A	2	T		F19	PR15A	2	T	
E20	PR6B	2	C		E20	PR14B	2	C	
D20	PR6A	2	T	RDQS6	D20	PR14A	2	T	RDQS14
C21	PR5B	2	C		C21	PR13B	2	C	
GND	-	-			GND	GND2	2		
C20	PR5A	2	T		C20	PR13A	2	T	
F18	PR4B	2	C		F18	PR12B	2	C	
E18	PR4A	2	T		E18	PR12A	2	T	
B22	PR3B	2	C		B22	PR11B	2	C	
B21	PR3A	2	T		B21	PR11A	2	T	
GND	-	-			GND	GND2	2		
E19	PR2B	2	C	VREF1_2	E19	PR2B	2	C	VREF1_2
D19	PR2A	2	T	VREF2_2	D19	PR2A	2	T	VREF2_2
GND	GND2	2			GND	GND2	2		
GND	GND1	1			GND	GND1	1		
GND	-	-			GND	GND1	1		
G17	PT57B	1	C		G17	PT57B	1	C	
GND	-	-			GND	GND1	1		
F17	PT57A	1	T		F17	PT57A	1	T	
D18	PT56B	1	C		D18	PT56B	1	C	
C18	PT56A	1	T		C18	PT56A	1	T	
C19	PT55B	1	C		C19	PT55B	1	C	
B20	PT55A	1	T		B20	PT55A	1	T	
D17	PT54B	1	C		D17	PT54B	1	C	
C16	PT54A	1	T	TDQS54	C16	PT54A	1	T	TDQS54
B19	PT53B	1	C		B19	PT53B	1	C	
GND	GND1	1			GND	GND1	1		
A20	PT53A	1	T		A20	PT53A	1	T	
E17	PT52B	1	C		E17	PT52B	1	C	
C17	PT52A	1	T		C17	PT52A	1	T	
F16	PT51B	1	C		F16	PT51B	1	C	
E16	PT51A	1	T		E16	PT51A	1	T	
F15	PT50B	1	C		F15	PT50B	1	C	
D16	PT50A	1	T		D16	PT50A	1	T	
B18	PT49B	1	C		B18	PT49B	1	C	
GND	GND1	1			GND	GND1	1		
A19	PT49A	1	T		A19	PT49A	1	T	
B17	PT48B	1	C		B17	PT48B	1	C	
A18	PT48A	1	T		A18	PT48A	1	T	
B16	PT47B	1	C		B16	PT47B	1	C	
A17	PT47A	1	T		A17	PT47A	1	T	

**LFECP/EC20 and LFECP/EC33 Logic Signal Connections: 484 fpBGA**

LFECP20/LFEC20					LFECP/LFEC33				
Ball Number	Ball Function	Bank	LVDS	Dual Function	Ball Number	Ball Function	Bank	LVDS	Dual Function
B15	PT46B	1	C		B15	PT46B	1	C	
A16	PT46A	1	T	TDQS46	A16	PT46A	1	T	TDQS46
A15	PT45B	1	C		A15	PT45B	1	C	
GND	GND1	1			GND	GND1	1		
A14	PT45A	1	T		A14	PT45A	1	T	
G14	PT44B	1	C		G14	PT44B	1	C	
E15	PT44A	1	T		E15	PT44A	1	T	
D15	PT43B	1	C		D15	PT43B	1	C	
C15	PT43A	1	T		C15	PT43A	1	T	
C14	PT42B	1	C		C14	PT42B	1	C	
B14	PT42A	1	T		B14	PT42A	1	T	
A13	PT41B	1	C		A13	PT41B	1	C	
GND	GND1	1			GND	GND1	1		
B13	PT41A	1	T		B13	PT41A	1	T	
E14	PT40B	1	C		E14	PT40B	1	C	
C13	PT40A	1	T		C13	PT40A	1	T	
F14	PT39B	1	C		F14	PT39B	1	C	
D14	PT39A	1	T		D14	PT39A	1	T	
E13	PT38B	1	C		E13	PT38B	1	C	
G13	PT38A	1	T	TDQS38	G13	PT38A	1	T	TDQS38
A12	PT37B	1	C		A12	PT37B	1	C	
GND	GND1	1			GND	GND1	1		
B12	PT37A	1	T		B12	PT37A	1	T	
F13	PT36B	1	C		F13	PT36B	1	C	
D13	PT36A	1	T		D13	PT36A	1	T	
F12	PT35B	1	C	VREF2_1	F12	PT35B	1	C	VREF2_1
D12	PT35A	1	T	VREF1_1	D12	PT35A	1	T	VREF1_1
F11	PT34B	1	C		F11	PT34B	1	C	
C12	PT34A	1	T		C12	PT34A	1	T	
A11	PT33B	0	C	PCLKC0_0	A11	PT33B	0	C	PCLKC0_0
GND	GND0	0			GND	GND0	0		
A10	PT33A	0	T	PCLKT0_0	A10	PT33A	0	T	PCLKT0_0
E12	PT32B	0	C	VREF1_0	E12	PT32B	0	C	VREF1_0
E11	PT32A	0	T	VREF2_0	E11	PT32A	0	T	VREF2_0
B11	PT31B	0	C		B11	PT31B	0	C	
C11	PT31A	0	T		C11	PT31A	0	T	
B9	PT30B	0	C		B9	PT30B	0	C	
B10	PT30A	0	T	TDQS30	B10	PT30A	0	T	TDQS30
A9	PT29B	0	C		A9	PT29B	0	C	
GND	GND0	0			GND	GND0	0		
A8	PT29A	0	T		A8	PT29A	0	T	
D11	PT28B	0	C		D11	PT28B	0	C	
C10	PT28A	0	T		C10	PT28A	0	T	
A7	PT27B	0	C		A7	PT27B	0	C	

**LFECP/EC20 and LFECP/EC33 Logic Signal Connections: 484 fpBGA**

LFECP20/LFEC20					LFECP/LFEC33				
Ball Number	Ball Function	Bank	LVDS	Dual Function	Ball Number	Ball Function	Bank	LVDS	Dual Function
A6	PT27A	0	T		A6	PT27A	0	T	
B7	PT26B	0	C		B7	PT26B	0	C	
B8	PT26A	0	T		B8	PT26A	0	T	
A5	PT25B	0	C		A5	PT25B	0	C	
GND	GND0	0			GND	GND0	0		
B6	PT25A	0	T		B6	PT25A	0	T	
G10	PT24B	0	C		G10	PT24B	0	C	
E10	PT24A	0	T		E10	PT24A	0	T	
F10	PT23B	0	C		F10	PT23B	0	C	
D10	PT23A	0	T		D10	PT23A	0	T	
G9	PT22B	0	C		G9	PT22B	0	C	
E9	PT22A	0	T	TDQS22	E9	PT22A	0	T	TDQS22
C9	PT21B	0	C		C9	PT21B	0	C	
GND	GND0	0			GND	GND0	0		
C8	PT21A	0	T		C8	PT21A	0	T	
F9	PT20B	0	C		F9	PT20B	0	C	
D9	PT20A	0	T		D9	PT20A	0	T	
F8	PT19B	0	C		F8	PT19B	0	C	
D7	PT19A	0	T		D7	PT19A	0	T	
D8	PT18B	0	C		D8	PT18B	0	C	
C7	PT18A	0	T		C7	PT18A	0	T	
GND	GND0	0			GND	GND0	0		
A4	PT17B	0	C		A4	PT17B	0	C	
B4	PT17A	0	T		B4	PT17A	0	T	
C4	PT16B	0	C		C4	PT16B	0	C	
C5	PT16A	0	T		C5	PT16A	0	T	
D6	PT15B	0	C		D6	PT15B	0	C	
B5	PT15A	0	T		B5	PT15A	0	T	
E6	PT14B	0	C		E6	PT14B	0	C	
C6	PT14A	0	T	TDQS14	C6	PT14A	0	T	TDQS14
A3	PT13B	0	C		A3	PT13B	0	C	
GND	GND0	0			GND	GND0	0		
B3	PT13A	0	T		B3	PT13A	0	T	
F6	PT12B	0	C		F6	PT12B	0	C	
D5	PT12A	0	T		D5	PT12A	0	T	
F7	PT11B	0	C		F7	PT11B	0	C	
E8	PT11A	0	T		E8	PT11A	0	T	
G6	PT10B	0	C		G6	PT10B	0	C	
E7	PT10A	0	T		E7	PT10A	0	T	
GND	GND0	0			GND	GND0	0		
GND	GND0	0			GND	GND0	0		
A1	GND	-			A1	GND	-		
A22	GND	-			A22	GND	-		
AB1	GND	-			AB1	GND	-		

**LFECP/EC20 and LFECP/EC33 Logic Signal Connections: 484 fpBGA**

LFECP20/LFEC20					LFECP/LFEC33				
Ball Number	Ball Function	Bank	LVDS	Dual Function	Ball Number	Ball Function	Bank	LVDS	Dual Function
AB22	GND	-			AB22	GND	-		
H15	GND	-			H15	GND	-		
H8	GND	-			H8	GND	-		
J10	GND	-			J10	GND	-		
J11	GND	-			J11	GND	-		
J12	GND	-			J12	GND	-		
J13	GND	-			J13	GND	-		
J14	GND	-			J14	GND	-		
J9	GND	-			J9	GND	-		
K10	GND	-			K10	GND	-		
K11	GND	-			K11	GND	-		
K12	GND	-			K12	GND	-		
K13	GND	-			K13	GND	-		
K14	GND	-			K14	GND	-		
K9	GND	-			K9	GND	-		
L10	GND	-			L10	GND	-		
L11	GND	-			L11	GND	-		
L12	GND	-			L12	GND	-		
L13	GND	-			L13	GND	-		
L14	GND	-			L14	GND	-		
L9	GND	-			L9	GND	-		
M10	GND	-			M10	GND	-		
M11	GND	-			M11	GND	-		
M12	GND	-			M12	GND	-		
M13	GND	-			M13	GND	-		
M14	GND	-			M14	GND	-		
M9	GND	-			M9	GND	-		
N10	GND	-			N10	GND	-		
N11	GND	-			N11	GND	-		
N12	GND	-			N12	GND	-		
N13	GND	-			N13	GND	-		
N14	GND	-			N14	GND	-		
N9	GND	-			N9	GND	-		
P10	GND	-			P10	GND	-		
P11	GND	-			P11	GND	-		
P12	GND	-			P12	GND	-		
P13	GND	-			P13	GND	-		
P14	GND	-			P14	GND	-		
P9	GND	-			P9	GND	-		
R15	GND	-			R15	GND	-		
R8	GND	-			R8	GND	-		
J16	VCC	-			J16	VCC	-		
J7	VCC	-			J7	VCC	-		
K16	VCC	-			K16	VCC	-		

**LFECP/EC20 and LFECP/EC33 Logic Signal Connections: 484 fpBGA**

LFECP20/LFEC20					LFECP/LFEC33				
Ball Number	Ball Function	Bank	LVDS	Dual Function	Ball Number	Ball Function	Bank	LVDS	Dual Function
K17	VCC	-			K17	VCC	-		
K6	VCC	-			K6	VCC	-		
K7	VCC	-			K7	VCC	-		
L17	VCC	-			L17	VCC	-		
L6	VCC	-			L6	VCC	-		
M17	VCC	-			M17	VCC	-		
M6	VCC	-			M6	VCC	-		
N16	VCC	-			N16	VCC	-		
N17	VCC	-			N17	VCC	-		
N6	VCC	-			N6	VCC	-		
N7	VCC	-			N7	VCC	-		
P16	VCC	-			P16	VCC	-		
P7	VCC	-			P7	VCC	-		
G11	VCCIO0	0			G11	VCCIO0	0		
H10	VCCIO0	0			H10	VCCIO0	0		
H11	VCCIO0	0			H11	VCCIO0	0		
H9	VCCIO0	0			H9	VCCIO0	0		
G12	VCCIO1	1			G12	VCCIO1	1		
H12	VCCIO1	1			H12	VCCIO1	1		
H13	VCCIO1	1			H13	VCCIO1	1		
H14	VCCIO1	1			H14	VCCIO1	1		
J15	VCCIO2	2			J15	VCCIO2	2		
K15	VCCIO2	2			K15	VCCIO2	2		
L15	VCCIO2	2			L15	VCCIO2	2		
L16	VCCIO2	2			L16	VCCIO2	2		
M15	VCCIO3	3			M15	VCCIO3	3		
M16	VCCIO3	3			M16	VCCIO3	3		
N15	VCCIO3	3			N15	VCCIO3	3		
P15	VCCIO3	3			P15	VCCIO3	3		
R12	VCCIO4	4			R12	VCCIO4	4		
R13	VCCIO4	4			R13	VCCIO4	4		
R14	VCCIO4	4			R14	VCCIO4	4		
T12	VCCIO4	4			T12	VCCIO4	4		
R10	VCCIO5	5			R10	VCCIO5	5		
R11	VCCIO5	5			R11	VCCIO5	5		
R9	VCCIO5	5			R9	VCCIO5	5		
T11	VCCIO5	5			T11	VCCIO5	5		
M7	VCCIO6	6			M7	VCCIO6	6		
M8	VCCIO6	6			M8	VCCIO6	6		
N8	VCCIO6	6			N8	VCCIO6	6		
P8	VCCIO6	6			P8	VCCIO6	6		
J8	VCCIO7	7			J8	VCCIO7	7		
K8	VCCIO7	7			K8	VCCIO7	7		
L7	VCCIO7	7			L7	VCCIO7	7		

**LFECP/EC20 and LFECP/EC33 Logic Signal Connections: 484 fpBGA**

LFECP20/LFEC20					LFECP/LFEC33				
Ball Number	Ball Function	Bank	LVDS	Dual Function	Ball Number	Ball Function	Bank	LVDS	Dual Function
L8	VCCIO7	7			L8	VCCIO7	7		
G15	VCCAUX	-			G15	VCCAUX	-		
G16	VCCAUX	-			G16	VCCAUX	-		
G7	VCCAUX	-			G7	VCCAUX	-		
G8	VCCAUX	-			G8	VCCAUX	-		
H16	VCCAUX	-			H16	VCCAUX	-		
H7	VCCAUX	-			H7	VCCAUX	-		
R16	VCCAUX	-			R16	VCCAUX	-		
R7	VCCAUX	-			R7	VCCAUX	-		
T15	VCCAUX	-			T15	VCCAUX	-		
T16	VCCAUX	-			T16	VCCAUX	-		
T7	VCCAUX	-			T7	VCCAUX	-		
T8	VCCAUX	-			T8	VCCAUX	-		
J6	VCC <sup>1</sup>	-			J6	VCCPLL	-		
J17	VCC <sup>1</sup>	-			J17	VCCPLL	-		
P6	VCC <sup>1</sup>	-			P6	VCCPLL	-		
P17	VCC <sup>1</sup>	-			P17	VCCPLL	-		
A2	NC	-			A2	NC	-		
AB2	NC	-			AB2	NC	-		
A21	NC	-			A21	NC	-		

1. Tied to V<sub>CCPLL</sub>.

**LFCEP/EC20, LFCEP/EC33 Logic Signal Connections: 672 fpBGA**

LFCEP/EC20					LFCEP/EC33				
Ball Number	Ball Function	Bank	LVDS	Dual Function	Ball Number	Ball Function	Bank	LVDS	Dual Function
GND	GND7	7			GND	GND7	7		
E3	PL2A	7	T	VREF2_7	E3	PL2A	7	T	VREF2_7
E4	PL2B	7	C	VREF1_7	E4	PL2B	7	C	VREF1_7
E5	NC	-			E5	PL6A	7	T	LDQS6
D5	NC	-			D5	PL6B	7	C	
F4	NC	-			F4	PL7A	7	T	
F5	NC	-			F5	PL7B	7	C	
C3	NC	-			C3	PL8A	7	T	
D3	NC	-			D3	PL8B	7	C	
C2	NC	-			C2	PL9A	7	T	
-	-	-			GND	GND7	7		
B2	NC	-			B2	PL9B	7	C	
B1	PL3A	7	T		B1	PL10A	7	T	
C1	PL3B	7	C		C1	PL10B	7	C	
F3	PL4A	7	T		F3	PL11A	7	T	
G3	PL4B	7	C		G3	PL11B	7	C	
D2	PL5A	7	T		D2	PL12A	7	T	
E2	PL5B	7	C		E2	PL12B	7	C	
-	-	-			GND	GND7	7		
D1	PL6A	7	T	LDQS6	D1	PL14A	7	T	LDQS14
E1	PL6B	7	C		E1	PL14B	7	C	
F2	PL7A	7	T		F2	PL15A	7	T	
G2	PL7B	7	C		G2	PL15B	7	C	
F6	PL8A	7	T	LUM0_PLLT_IN_A	F6	PL16A	7	T	LUM0_PLLT_IN_A
G6	PL8B	7	C	LUM0_PLLC_IN_A	G6	PL16B	7	C	LUM0_PLLC_IN_A
H4	PL9A	7	T	LUM0_PLLT_FB_A	H4	PL17A	7	T	LUM0_PLLT_FB_A
GND	GND7	7			GND	GND7	7		
G4	PL9B	7	C	LUM0_PLLC_FB_A	G4	PL17B	7	C	LUM0_PLLC_FB_A
H6	NC	-			H6	PL19A	7	T	
J7	NC	-			J7	PL19B	7	C	
G5	NC	-			G5	PL20A	7	T	
H5	NC	-			H5	PL20B	7	C	
H3	NC	-			H3	PL21A	7	T	
J3	NC	-			J3	PL21B	7	C	
H2	NC	-			H2	PL22A	7	T	
-	-	-			GND	GND7	7		
J2	NC	-			J2	PL22B	7	C	
J4	PL11A	7	T		J4	PL23A	7	T	LDQS23
J5	PL11B	7	C		J5	PL23B	7	C	
K4	PL12A	7	T		K4	PL24A	7	T	
K5	PL12B	7	C		K5	PL24B	7	C	
J6	PL13A	7	T		J6	PL25A	7	T	



**LFCEP/EC20, LFCEP/EC33 Logic Signal Connections: 672 fpBGA (Cont.)**

LFCEP/EC20					LFCEP/EC33				
Ball Number	Ball Function	Bank	LVDS	Dual Function	Ball Number	Ball Function	Bank	LVDS	Dual Function
K6	PL13B	7	C		K6	PL25B	7	C	
F1	PL14A	7	T		F1	PL26A	7	T	
GND	GND7	7			GND	GND7	7		
G1	PL14B	7	C		G1	PL26B	7	C	
H1	PL15A	7	T		H1	PL27A	7	T	
J1	PL15B	7	C		J1	PL27B	7	C	
K2	PL16A	7	T		K2	PL28A	7	T	
K1	PL16B	7	C		K1	PL28B	7	C	
K3	PL17A	7	T		K3	PL29A	7	T	
L3	PL17B	7	C		L3	PL29B	7	C	
L2	PL18A	7	T		L2	PL30A	7	T	
GND	GND7	7			GND	GND7	7		
L1	PL18B	7	C		L1	PL30B	7	C	
M3	PL19A	7	T	LDQS19	M3	PL31A	7	T	LDQS31
M4	PL19B	7	C		M4	PL31B	7	C	
M1	PL20A	7	T		M1	PL32A	7	T	
M2	PL20B	7	C		M2	PL32B	7	C	
L4	PL21A	7	T		L4	PL33A	7	T	
L5	PL21B	7	C		L5	PL33B	7	C	
N2	PL22A	7	T	PCLKT7_0	N2	PL34A	7	T	PCLKT7_0
GND	GND7	7			GND	GND7	7		
N1	PL22B	7	C	PCLKC7_0	N1	PL34B	7	C	PCLKC7_0
N3	XRES	6			N3	XRES	6		
P1	PL24A	6	T		P1	PL36A	6	T	
P2	PL24B	6	C		P2	PL36B	6	C	
L7	PL25A	6	T		L7	PL37A	6	T	
L6	PL25B	6	C		L6	PL37B	6	C	
N4	PL26A	6	T		N4	PL38A	6	T	
N5	PL26B	6	C		N5	PL38B	6	C	
R1	PL27A	6	T		R1	PL39A	6	T	
GND	GND6	6			GND	GND6	6		
R2	PL27B	6	C		R2	PL39B	6	C	
P4	PL28A	6	T	LDQS28	P4	PL40A	6	T	LDQS40
P3	PL28B	6	C		P3	PL40B	6	C	
M5	PL29A	6	T		M5	PL41A	6	T	
M6	PL29B	6	C		M6	PL41B	6	C	
T1	PL30A	6	T		T1	PL42A	6	T	
T2	PL30B	6	C		T2	PL42B	6	C	
R4	PL31A	6	T		R4	PL43A	6	T	
GND	GND6	6			GND	GND6	6		
R3	PL31B	6	C		R3	PL43B	6	C	
N6	PL32A	6	T		N6	PL44A	6	T	

**LFECP/EC20, LFECP/EC33 Logic Signal Connections: 672 fpBGA (Cont.)**

LFEC20/LFECP20					LFECP/EC33				
Ball Number	Ball Function	Bank	LVDS	Dual Function	Ball Number	Ball Function	Bank	LVDS	Dual Function
P5	PL32B	6	C		P5	PL44B	6	C	
P6	PL33A	6	T		P6	PL45A	6	T	
R5	PL33B	6	C		R5	PL45B	6	C	
U1	PL34A	6	T		U1	PL46A	6	T	
U2	PL34B	6	C		U2	PL46B	6	C	
T3	PL35A	6	T		T3	PL47A	6	T	
GND	GND6	6			GND	GND6	6		
T4	PL35B	6	C		T4	PL47B	6	C	
R6	PL36A	6	T	LDQS36	R6	PL48A	6	T	LDQS48
T5	PL36B	6	C		T5	PL48B	6	C	
T6	PL37A	6	T		T6	PL49A	6	T	
U5	PL37B	6	C		U5	PL49B	6	C	
U3	PL38A	6	T		U3	PL50A	6	T	
U4	PL38B	6	C		U4	PL50B	6	C	
V1	PL39A	6	T		V1	PL51A	6	T	
GND	GND6	6			GND	GND6	6		
V2	PL39B	6	C		V2	PL51B	6	C	
U7	TCK	6			U7	TCK	6		
V4	TDI	6			V4	TDI	6		
V5	TMS	6			V5	TMS	6		
V3	TDO	6			V3	TDO	6		
U6	VCCJ	6			U6	VCCJ	6		
W1	PL41A	6	T	LLM0_PLLT_IN_A	W1	PL53A	6	T	LLM0_PLLT_IN_A
W2	PL41B	6	C	LLM0_PLLC_IN_A	W2	PL53B	6	C	LLM0_PLLC_IN_A
V6	PL42A	6	T	LLM0_PLLT_FB_A	V6	PL54A	6	T	LLM0_PLLT_FB_A
W6	PL42B	6	C	LLM0_PLLC_FB_A	W6	PL54B	6	C	LLM0_PLLC_FB_A
Y1	PL43A	6	T		Y1	PL55A	6	T	
Y2	PL43B	6	C		Y2	PL55B	6	C	
W3	PL44A	6	T		W3	PL56A	6	T	
GND	GND6	6			GND	GND6	6		
W4	PL44B	6	C		W4	PL56B	6	C	
AA1	PL45A	6	T	LDQS45	AA1	PL57A	6	T	LDQS57
AB1	PL45B	6	C		AB1	PL57B	6	C	
Y4	PL46A	6	T		Y4	PL58A	6	T	
Y3	PL46B	6	C		Y3	PL58B	6	C	
AC1	PL47A	6	T		AC1	PL59A	6	T	
AB2	PL47B	6	C		AB2	PL59B	6	C	
AA2	NC	-			AA2	PL60A	6	T	
-	-	-			GND	GND6	6		
AA3	NC	-			AA3	PL60B	6	C	
W5	NC	-			W5	PL61A	6	T	
Y5	NC	-			Y5	PL61B	6	C	

**LFCEP/EC20, LFCEP/EC33 Logic Signal Connections: 672 fpBGA (Cont.)**

LFCEP/EC20					LFCEP/EC33				
Ball Number	Ball Function	Bank	LVDS	Dual Function	Ball Number	Ball Function	Bank	LVDS	Dual Function
Y6	NC	-			Y6	PL62A	6	T	
W7	NC	-			W7	PL62B	6	C	
AA4	NC	-			AA4	PL63A	6	T	
AB3	NC	-			AB3	PL63B	6	C	
AC2	NC	-			AC2	PL64A	6	T	
-	-	-			GND	GND6	6		
AC3	NC	-			AC3	PL64B	6	C	
AA5	NC	-			AA5	PL65A	6	T	LDQS65
AB5	NC	-			AB5	PL65B	6	C	
AD3	NC	-			AD3	PL66A	6	T	
AD2	NC	-			AD2	PL66B	6	C	
AE1	NC	-			AE1	PL67A	6	T	
AD1	NC	-			AD1	PL67B	6	C	
AB4	PL48A	6	T	VREF1_6	AB4	PL68A	6	T	VREF1_6
AC4	PL48B	6	C	VREF2_6	AC4	PL68B	6	C	VREF2_6
GND	GND6	6			GND	GND6	6		
GND	GND5	5			GND	GND5	5		
AB6	PB2A	5	T		AB6	PB2A	5	T	
AA6	PB2B	5	C		AA6	PB2B	5	C	
AC7	PB3A	5	T		AC7	PB3A	5	T	
Y8	PB3B	5	C		Y8	PB3B	5	C	
AB7	PB4A	5	T		AB7	PB4A	5	T	
AA7	PB4B	5	C		AA7	PB4B	5	C	
AC6	PB5A	5	T		AC6	PB5A	5	T	
AC5	PB5B	5	C		AC5	PB5B	5	C	
AB8	PB6A	5	T	BDQS6	AB8	PB6A	5	T	BDQS6
AC8	PB6B	5	C		AC8	PB6B	5	C	
AE2	PB7A	5	T		AE2	PB7A	5	T	
AA8	PB7B	5	C		AA8	PB7B	5	C	
AF2	PB8A	5	T		AF2	PB8A	5	T	
Y9	PB8B	5	C		Y9	PB8B	5	C	
AD5	PB9A	5	T		AD5	PB9A	5	T	
GND	GND5	5			GND	GND5	5		
AD4	PB9B	5	C		AD4	PB9B	5	C	
AD8	PB10A	5	T		AD8	PB10A	5	T	
AC9	PB10B	5	C		AC9	PB10B	5	C	
AE3	PB11A	5	T		AE3	PB11A	5	T	
AB9	PB11B	5	C		AB9	PB11B	5	C	
AF3	PB12A	5	T		AF3	PB12A	5	T	
AD9	PB12B	5	C		AD9	PB12B	5	C	
AE4	PB13A	5	T		AE4	PB13A	5	T	
GND	GND5	5			GND	GND5	5		

**LFECP/EC20, LFECP/EC33 Logic Signal Connections: 672 fpBGA (Cont.)**

LFEC20/LFECP20					LFECP/EC33				
Ball Number	Ball Function	Bank	LVDS	Dual Function	Ball Number	Ball Function	Bank	LVDS	Dual Function
AF4	PB13B	5	C		AF4	PB13B	5	C	
AE5	PB14A	5	T	BDQS14	AE5	PB14A	5	T	BDQS14
AA9	PB14B	5	C		AA9	PB14B	5	C	
AF5	PB15A	5	T		AF5	PB15A	5	T	
Y10	PB15B	5	C		Y10	PB15B	5	C	
AD6	PB16A	5	T		AD6	PB16A	5	T	
AC10	PB16B	5	C		AC10	PB16B	5	C	
AF6	PB17A	5	T		AF6	PB17A	5	T	
GND	GND5	5			GND	GND5	5		
AE6	PB17B	5	C		AE6	PB17B	5	C	
AF7	PB18A	5	T		AF7	PB18A	5	T	
AB10	PB18B	5	C		AB10	PB18B	5	C	
AE7	PB19A	5	T		AE7	PB19A	5	T	
AD10	PB19B	5	C		AD10	PB19B	5	C	
AD7	PB20A	5	T		AD7	PB20A	5	T	
AA10	PB20B	5	C		AA10	PB20B	5	C	
AF8	PB21A	5	T		AF8	PB21A	5	T	
GND	GND5	5			GND	GND5	5		
AF9	PB21B	5	C		AF9	PB21B	5	C	
AD11	PB22A	5	T	BDQS22	AD11	PB22A	5	T	BDQS22
Y11	PB22B	5	C		Y11	PB22B	5	C	
AE8	PB23A	5	T		AE8	PB23A	5	T	
AC11	PB23B	5	C		AC11	PB23B	5	C	
AF10	PB24A	5	T		AF10	PB24A	5	T	
AB11	PB24B	5	C		AB11	PB24B	5	C	
AE10	PB25A	5	T		AE10	PB25A	5	T	
GND	GND5	5			GND	GND5	5		
AE9	PB25B	5	C		AE9	PB25B	5	C	
AA11	PB26A	5	T		AA11	PB26A	5	T	
Y12	PB26B	5	C		Y12	PB26B	5	C	
AE11	PB27A	5	T		AE11	PB27A	5	T	
AF11	PB27B	5	C		AF11	PB27B	5	C	
AF12	PB28A	5	T		AF12	PB28A	5	T	
AE12	PB28B	5	C		AE12	PB28B	5	C	
AD12	PB29A	5	T		AD12	PB29A	5	T	
GND	GND5	5			GND	GND5	5		
AC12	PB29B	5	C		AC12	PB29B	5	C	
AA12	PB30A	5	T	BDQS30	AA12	PB30A	5	T	BDQS30
AB12	PB30B	5	C		AB12	PB30B	5	C	
AE13	PB31A	5	T		AE13	PB31A	5	T	
AF13	PB31B	5	C		AF13	PB31B	5	C	
AD13	PB32A	5	T	VREF2_5	AD13	PB32A	5	T	VREF2_5

**LFCEP/EC20, LFCEP/EC33 Logic Signal Connections: 672 fpBGA (Cont.)**

LFCEP/EC20					LFCEP/EC33				
Ball Number	Ball Function	Bank	LVDS	Dual Function	Ball Number	Ball Function	Bank	LVDS	Dual Function
AC13	PB32B	5	C	VREF1_5	AC13	PB32B	5	C	VREF1_5
AF14	PB33A	5	T	PCLKT5_0	AF14	PB33A	5	T	PCLKT5_0
GND	GND5	5			GND	GND5	5		
AE14	PB33B	5	C	PCLKC5_0	AE14	PB33B	5	C	PCLKC5_0
AA13	PB34A	4	T	WRITEN	AA13	PB34A	4	T	WRITEN
AB13	PB34B	4	C	CS1N	AB13	PB34B	4	C	CS1N
AD14	PB35A	4	T	VREF1_4	AD14	PB35A	4	T	VREF1_4
AA14	PB35B	4	C	CSN	AA14	PB35B	4	C	CSN
AC14	PB36A	4	T	VREF2_4	AC14	PB36A	4	T	VREF2_4
AB14	PB36B	4	C	D0/SPID7	AB14	PB36B	4	C	D0/SPID7
AF15	PB37A	4	T	D2/SPID5	AF15	PB37A	4	T	D2/SPID5
GND	GND4	4			GND	GND4	4		
AE15	PB37B	4	C	D1/SPID6	AE15	PB37B	4	C	D1/SPID6
AD15	PB38A	4	T	BDQS38	AD15	PB38A	4	T	BDQS38
AC15	PB38B	4	C	D3/SPID4	AC15	PB38B	4	C	D3/SPID4
AF16	PB39A	4	T		AF16	PB39A	4	T	
Y14	PB39B	4	C	D4/SPID3	Y14	PB39B	4	C	D4/SPID3
AE16	PB40A	4	T		AE16	PB40A	4	T	
AB15	PB40B	4	C	D5/SPID2	AB15	PB40B	4	C	D5/SPID2
AF17	PB41A	4	T		AF17	PB41A	4	T	
GND	GND4	4			GND	GND4	4		
AE17	PB41B	4	C	D6/SPID1	AE17	PB41B	4	C	D6/SPID1
Y15	PB42A	4	T		Y15	PB42A	4	T	
AA15	PB42B	4	C		AA15	PB42B	4	C	
AD17	PB43A	4	T		AD17	PB43A	4	T	
Y16	PB43B	4	C		Y16	PB43B	4	C	
AD18	PB44A	4	T		AD18	PB44A	4	T	
AC16	PB44B	4	C		AC16	PB44B	4	C	
AE18	PB45A	4	T		AE18	PB45A	4	T	
GND	GND4	4			GND	GND4	4		
AF18	PB45B	4	C		AF18	PB45B	4	C	
AD16	PB46A	4	T	BDQS46	AD16	PB46A	4	T	BDQS46
AB16	PB46B	4	C		AB16	PB46B	4	C	
AF19	PB47A	4	T		AF19	PB47A	4	T	
AA16	PB47B	4	C		AA16	PB47B	4	C	
AA17	PB48A	4	T		AA17	PB48A	4	T	
Y17	PB48B	4	C		Y17	PB48B	4	C	
AF21	PB49A	4	T		AF21	PB49A	4	T	
GND	GND4	4			GND	GND4	4		
AF20	PB49B	4	C		AF20	PB49B	4	C	
AE21	PB50A	4	T		AE21	PB50A	4	T	
AC17	PB50B	4	C		AC17	PB50B	4	C	

**LFECP/EC20, LFECP/EC33 Logic Signal Connections: 672 fpBGA (Cont.)**

LFEC20/LFECP20					LFECP/EC33				
Ball Number	Ball Function	Bank	LVDS	Dual Function	Ball Number	Ball Function	Bank	LVDS	Dual Function
AF22	PB51A	4	T		AF22	PB51A	4	T	
AB17	PB51B	4	C		AB17	PB51B	4	C	
AE22	PB52A	4	T		AE22	PB52A	4	T	
AA18	PB52B	4	C		AA18	PB52B	4	C	
AE19	PB53A	4	T		AE19	PB53A	4	T	
GND	GND4	4			GND	GND4	4		
AE20	PB53B	4	C		AE20	PB53B	4	C	
AA19	PB54A	4	T	BDQS54	AA19	PB54A	4	T	BDQS54
Y18	PB54B	4	C		Y18	PB54B	4	C	
AF23	PB55A	4	T		AF23	PB55A	4	T	
AA20	PB55B	4	C		AA20	PB55B	4	C	
AC18	PB56A	4	T		AC18	PB56A	4	T	
AB18	PB56B	4	C		AB18	PB56B	4	C	
AF24	PB57A	4	T		AF24	PB57A	4	T	
-	-	-			GND	GND4	4		
AE23	PB57B	4	C		AE23	PB57B	4	C	
AD19	NC	-			AD19	PB58A	4	T	
AD20	NC	-			AD20	PB58B	4	C	
AC19	NC	-			AC19	PB59A	4	T	
AB19	NC	-			AB19	PB59B	4	C	
AD21	NC	-			AD21	PB60A	4	T	
AC20	NC	-			AC20	PB60B	4	C	
AF25	NC	-			AF25	PB61A	4	T	
-	-	-			GND	GND4	4		
AE25	NC	-			AE25	PB61B	4	C	
AB21	NC	-			AB21	PB62A	4	T	BDQS62
AB20	NC	-			AB20	PB62B	4	C	
AE24	NC	-			AE24	PB63A	4	T	
AD23	NC	-			AD23	PB63B	4	C	
AD22	NC	-			AD22	PB64A	4	T	
AC21	NC	-			AC21	PB64B	4	C	
AC22	NC	-			AC22	PB65A	4	T	
AB22	NC	-			AB22	PB65B	4	C	
GND	GND4	4			GND	GND4	4		
GND	GND3	3			GND	GND3	3		
AC23	PR48B	3	C	VREF2_3	AC23	PR68B	3	C	VREF2_3
AC24	PR48A	3	T	VREF1_3	AC24	PR68A	3	T	VREF1_3
AD24	NC	-			AD24	PR67B	3	C	
AD25	NC	-			AD25	PR67A	3	T	
AE26	NC	-			AE26	PR66B	3	C	
AD26	NC	-			AD26	PR66A	3	T	
Y20	NC	-			Y20	PR65B	3	C	

**LFCEP/EC20, LFCEP/EC33 Logic Signal Connections: 672 fpBGA (Cont.)**

LFCEP/EC20					LFCEP/EC33				
Ball Number	Ball Function	Bank	LVDS	Dual Function	Ball Number	Ball Function	Bank	LVDS	Dual Function
Y19	NC	-			Y19	PR65A	3	T	RDQS65
AA23	NC	-			AA23	PR64B	3	C	
-	-	-			GND	GND3	3		
AA22	NC	-			AA22	PR64A	3	T	
AB23	NC	-			AB23	PR63B	3	C	
AB24	NC	-			AB24	PR63A	3	T	
Y21	NC	-			Y21	PR62B	3	C	
AA21	NC	-			AA21	PR62A	3	T	
Y23	NC	-			Y23	PR61B	3	C	
Y22	NC	-			Y22	PR61A	3	T	
AA24	NC	-			AA24	PR60B	3	C	
-	-	-			GND	GND3	3		
Y24	NC	-			Y24	PR60A	3	T	
AC25	PR47B	3	C		AC25	PR59B	3	C	
AC26	PR47A	3	T		AC26	PR59A	3	T	
AB25	PR46B	3	C		AB25	PR58B	3	C	
AA25	PR46A	3	T		AA25	PR58A	3	T	
AB26	PR45B	3	C		AB26	PR57B	3	C	
AA26	PR45A	3	T	RDQS45	AA26	PR57A	3	T	RDQS57
W23	PR44B	3	C	RLM0_PLLC_IN_A	W23	PR56B	3	C	RLM0_PLLC_IN_A
GND	GND3	3			GND	GND3	3		
W24	PR44A	3	T	RLM0_PLLT_IN_A	W24	PR56A	3	T	RLM0_PLLT_IN_A
W22	PR43B	3	C	RLM0_PLLC_FB_A	W22	PR55B	3	C	RLM0_PLLC_FB_A
W21	PR43A	3	T	RLM0_PLLT_FB_A	W21	PR55A	3	T	RLM0_PLLT_FB_A
Y25	PR42B	3	C	DI/CSSPIN	Y25	PR54B	3	C	DI/CSSPIN
Y26	PR42A	3	T	DOUT/CSON	Y26	PR54A	3	T	DOUT/CSON
W25	PR41B	3	C	BUSY/SISPI	W25	PR53B	3	C	BUSY/SISPI
W26	PR41A	3	T	D7/SPID0	W26	PR53A	3	T	D7/SPID0
V24	CFG2	3			V24	CFG2	3		
V21	CFG1	3			V21	CFG1	3		
V23	CFG0	3			V23	CFG0	3		
V22	PROGRAMN	3			V22	PROGRAMN	3		
V20	CCLK	3			V20	CCLK	3		
V25	INITN	3			V25	INITN	3		
U20	DONE	3			U20	DONE	3		
V26	PR39B	3	C		V26	PR51B	3	C	
GND	GND3	3			GND	GND3	3		
U26	PR39A	3	T		U26	PR51A	3	T	
U24	PR38B	3	C		U24	PR50B	3	C	
U25	PR38A	3	T		U25	PR50A	3	T	
U23	PR37B	3	C		U23	PR49B	3	C	
U22	PR37A	3	T		U22	PR49A	3	T	

**LFECP/EC20, LFECP/EC33 Logic Signal Connections: 672 fpBGA (Cont.)**

LFEC20/LFECP20					LFECP/EC33				
Ball Number	Ball Function	Bank	LVDS	Dual Function	Ball Number	Ball Function	Bank	LVDS	Dual Function
U21	PR36B	3	C		U21	PR48B	3	C	
T21	PR36A	3	T	RDQS36	T21	PR48A	3	T	RDQS48
T25	PR35B	3	C		T25	PR47B	3	C	
GND	GND3	3			GND	GND3	3		
T26	PR35A	3	T		T26	PR47A	3	T	
T22	PR34B	3	C		T22	PR46B	3	C	
T23	PR34A	3	T		T23	PR46A	3	T	
T24	PR33B	3	C		T24	PR45B	3	C	
R23	PR33A	3	T		R23	PR45A	3	T	
R25	PR32B	3	C		R25	PR44B	3	C	
R24	PR32A	3	T		R24	PR44A	3	T	
R26	PR31B	3	C		R26	PR43B	3	C	
GND	GND3	3			GND	GND3	3		
P26	PR31A	3	T		P26	PR43A	3	T	
R21	PR30B	3	C		R21	PR42B	3	C	
R22	PR30A	3	T		R22	PR42A	3	T	
P25	PR29B	3	C		P25	PR41B	3	C	
P24	PR29A	3	T		P24	PR41A	3	T	
P23	PR28B	3	C		P23	PR40B	3	C	
P22	PR28A	3	T	RDQS28	P22	PR40A	3	T	RDQS40
N26	PR27B	3	C		N26	PR39B	3	C	
GND	GND3	3			GND	GND3	3		
M26	PR27A	3	T		M26	PR39A	3	T	
N21	PR26B	3	C		N21	PR38B	3	C	
P21	PR26A	3	T		P21	PR38A	3	T	
N23	PR25B	3	C		N23	PR37B	3	C	
N22	PR25A	3	T		N22	PR37A	3	T	
N25	PR24B	3	C		N25	PR36B	3	C	
N24	PR24A	3	T		N24	PR36A	3	T	
L26	PR22B	2	C	PCLKC2_0	L26	PR34B	2	C	PCLKC2_0
GND	GND2	2			GND	GND2	2		
K26	PR22A	2	T	PCLKT2_0	K26	PR34A	2	T	PCLKT2_0
M22	PR21B	2	C		M22	PR33B	2	C	
M23	PR21A	2	T		M23	PR33A	2	T	
M25	PR20B	2	C		M25	PR32B	2	C	
M24	PR20A	2	T		M24	PR32A	2	T	
M21	PR19B	2	C		M21	PR31B	2	C	
L21	PR19A	2	T	RDQS19	L21	PR31A	2	T	RDQS31
L22	PR18B	2	C		L22	PR30B	2	C	
GND	GND2	2			GND	GND2	2		
L23	PR18A	2	T		L23	PR30A	2	T	
L25	PR17B	2	C		L25	PR29B	2	C	



**LFECP/EC20, LFECP/EC33 Logic Signal Connections: 672 fpBGA (Cont.)**

LFEC20/LFECP20					LFECP/EC33				
Ball Number	Ball Function	Bank	LVDS	Dual Function	Ball Number	Ball Function	Bank	LVDS	Dual Function
L24	PR17A	2	T		L24	PR29A	2	T	
K25	PR16B	2	C		K25	PR28B	2	C	
J25	PR16A	2	T		J25	PR28A	2	T	
J26	PR15B	2	C		J26	PR27B	2	C	
H26	PR15A	2	T		H26	PR27A	2	T	
H25	PR14B	2	C		H25	PR26B	2	C	
GND	GND2	2			GND	GND2	2		
J24	PR14A	2	T		J24	PR26A	2	T	
K21	PR13B	2	C		K21	PR25B	2	C	
K22	PR13A	2	T		K22	PR25A	2	T	
K20	PR12B	2	C		K20	PR24B	2	C	
J20	PR12A	2	T		J20	PR24A	2	T	
K23	PR11B	2	C		K23	PR23B	2	C	
K24	PR11A	2	T		K24	PR23A	2	T	RDQS23
J21	NC	-			J21	PR22B	2	C	
-	-	-			GND	GND2	2		
J22	NC	-			J22	PR22A	2	T	
J23	NC	-			J23	PR21B	2	C	
H22	NC	-			H22	PR21A	2	T	
G26	NC	-			G26	PR20B	2	C	
F26	NC	-			F26	PR20A	2	T	
E26	NC	-			E26	PR19B	2	C	
E25	NC	-			E25	PR19A	2	T	
F25	PR9B	2	C	RUM0_PLLC_FB_A	F25	PR17B	2	C	RUM0_PLLC_FB_A
GND	GND2	2			GND	GND2	2		
G25	PR9A	2	T	RUM0_PLLT_FB_A	G25	PR17A	2	T	RUM0_PLLT_FB_A
H23	PR8B	2	C	RUM0_PLLC_IN_A	H23	PR16B	2	C	RUM0_PLLC_IN_A
H24	PR8A	2	T	RUM0_PLLT_IN_A	H24	PR16A	2	T	RUM0_PLLT_IN_A
H21	PR7B	2	C		H21	PR15B	2	C	
G21	PR7A	2	T		G21	PR15A	2	T	
D26	PR6B	2	C		D26	PR14B	2	C	
D25	PR6A	2	T	RDQS6	D25	PR14A	2	T	RDQS14
F21	PR5B	2	C		F21	PR13B	2	C	
-	-	-			GND	GND2	2		
G22	PR5A	2	T		G22	PR13A	2	T	
G24	PR4B	2	C		G24	PR12B	2	C	
G23	PR4A	2	T		G23	PR12A	2	T	
C26	PR3B	2	C		C26	PR11B	2	C	
C25	PR3A	2	T		C25	PR11A	2	T	
F24	NC	-			F24	PR9B	2	C	
-	-	-			GND	GND2	2		
F23	NC	-			F23	PR9A	2	T	

**LFCEP/EC20, LFCEP/EC33 Logic Signal Connections: 672 fpBGA (Cont.)**

LFCEP/EC20					LFCEP/EC33				
Ball Number	Ball Function	Bank	LVDS	Dual Function	Ball Number	Ball Function	Bank	LVDS	Dual Function
E24	NC	-			E24	PR8B	2	C	
D24	NC	-			D24	PR8A	2	T	
E22	NC	-			E22	PR7B	2	C	
F22	NC	-			F22	PR7A	2	T	
E21	NC	-			E21	PR6B	2	C	
D22	NC	-			D22	PR6A	2	T	RDQS6
E23	PR2B	2	C	VREF1_2	E23	PR2B	2	C	VREF1_2
D23	PR2A	2	T	VREF2_2	D23	PR2A	2	T	VREF2_2
GND	GND2	2			GND	GND2	2		
GND	GND1	1			GND	GND1	1		
G20	NC	-			G20	PT65B	1	C	
F20	NC	-			F20	PT65A	1	T	
D21	NC	-			D21	PT64B	1	C	
C21	NC	-			C21	PT64A	1	T	
C23	NC	-			C23	PT63B	1	C	
C22	NC	-			C22	PT63A	1	T	
B23	NC	-			B23	PT62B	1	C	
C24	NC	-			C24	PT62A	1	T	TDQS62
D20	NC	-			D20	PT61B	1	C	
-	-	-			GND	GND1	1		
E19	NC	-			E19	PT61A	1	T	
B25	NC	-			B25	PT60B	1	C	
B24	NC	-			B24	PT60A	1	T	
B26	NC	-			B26	PT59B	1	C	
A25	NC	-			A25	PT59A	1	T	
C20	NC	-			C20	PT58B	1	C	
C19	NC	-			C19	PT58A	1	T	
A24	PT57B	1	C		A24	PT57B	1	C	
-	-	-			GND	GND1	1		
A23	PT57A	1	T		A23	PT57A	1	T	
E18	PT56B	1	C		E18	PT56B	1	C	
D19	PT56A	1	T		D19	PT56A	1	T	
F19	PT55B	1	C		F19	PT55B	1	C	
B22	PT55A	1	T		B22	PT55A	1	T	
G19	PT54B	1	C		G19	PT54B	1	C	
B21	PT54A	1	T	TDQS54	B21	PT54A	1	T	TDQS54
D18	PT53B	1	C		D18	PT53B	1	C	
GND	GND1	1			GND	GND1	1		
C18	PT53A	1	T		C18	PT53A	1	T	
F18	PT52B	1	C		F18	PT52B	1	C	
A22	PT52A	1	T		A22	PT52A	1	T	
G18	PT51B	1	C		G18	PT51B	1	C	

**LFCEP/EC20, LFCEP/EC33 Logic Signal Connections: 672 fpBGA (Cont.)**

LFCEP/EC20					LFCEP/EC33				
Ball Number	Ball Function	Bank	LVDS	Dual Function	Ball Number	Ball Function	Bank	LVDS	Dual Function
A21	PT51A	1	T		A21	PT51A	1	T	
E17	PT50B	1	C		E17	PT50B	1	C	
B17	PT50A	1	T		B17	PT50A	1	T	
C17	PT49B	1	C		C17	PT49B	1	C	
GND	GND1	1			GND	GND1	1		
D17	PT49A	1	T		D17	PT49A	1	T	
F17	PT48B	1	C		F17	PT48B	1	C	
E20	PT48A	1	T		E20	PT48A	1	T	
G17	PT47B	1	C		G17	PT47B	1	C	
B20	PT47A	1	T		B20	PT47A	1	T	
E16	PT46B	1	C		E16	PT46B	1	C	
A20	PT46A	1	T	TDQS46	A20	PT46A	1	T	TDQS46
A19	PT45B	1	C		A19	PT45B	1	C	
GND	GND1	1			GND	GND1	1		
B19	PT45A	1	T		B19	PT45A	1	T	
D16	PT44B	1	C		D16	PT44B	1	C	
C16	PT44A	1	T		C16	PT44A	1	T	
F16	PT43B	1	C		F16	PT43B	1	C	
A18	PT43A	1	T		A18	PT43A	1	T	
G16	PT42B	1	C		G16	PT42B	1	C	
B18	PT42A	1	T		B18	PT42A	1	T	
A17	PT41B	1	C		A17	PT41B	1	C	
GND	GND1	1			GND	GND1	1		
A16	PT41A	1	T		A16	PT41A	1	T	
D15	PT40B	1	C		D15	PT40B	1	C	
B16	PT40A	1	T		B16	PT40A	1	T	
E15	PT39B	1	C		E15	PT39B	1	C	
C15	PT39A	1	T		C15	PT39A	1	T	
F15	PT38B	1	C		F15	PT38B	1	C	
G15	PT38A	1	T	TDQS38	G15	PT38A	1	T	TDQS38
B15	PT37B	1	C		B15	PT37B	1	C	
GND	GND1	1			GND	GND1	1		
A15	PT37A	1	T		A15	PT37A	1	T	
E14	PT36B	1	C		E14	PT36B	1	C	
G14	PT36A	1	T		G14	PT36A	1	T	
D14	PT35B	1	C	VREF2_1	D14	PT35B	1	C	VREF2_1
E13	PT35A	1	T	VREF1_1	E13	PT35A	1	T	VREF1_1
F14	PT34B	1	C		F14	PT34B	1	C	
C14	PT34A	1	T		C14	PT34A	1	T	
B14	PT33B	0	C	PCLKC0_0	B14	PT33B	0	C	PCLKC0_0
GND	GND0	0			GND	GND0	0		
A14	PT33A	0	T	PCLKT0_0	A14	PT33A	0	T	PCLKT0_0

**LFECP/EC20, LFECP/EC33 Logic Signal Connections: 672 fpBGA (Cont.)**

LFEC20/LFECP20					LFECP/EC33				
Ball Number	Ball Function	Bank	LVDS	Dual Function	Ball Number	Ball Function	Bank	LVDS	Dual Function
D13	PT32B	0	C	VREF1_0	D13	PT32B	0	C	VREF1_0
C13	PT32A	0	T	VREF2_0	C13	PT32A	0	T	VREF2_0
A13	PT31B	0	C		A13	PT31B	0	C	
B13	PT31A	0	T		B13	PT31A	0	T	
F13	PT30B	0	C		F13	PT30B	0	C	
F12	PT30A	0	T	TDQS30	F12	PT30A	0	T	TDQS30
A12	PT29B	0	C		A12	PT29B	0	C	
GND	GND0	0			GND	GND0	0		
B12	PT29A	0	T		B12	PT29A	0	T	
A11	PT28B	0	C		A11	PT28B	0	C	
B11	PT28A	0	T		B11	PT28A	0	T	
D12	PT27B	0	C		D12	PT27B	0	C	
C12	PT27A	0	T		C12	PT27A	0	T	
B10	PT26B	0	C		B10	PT26B	0	C	
A10	PT26A	0	T		A10	PT26A	0	T	
G12	PT25B	0	C		G12	PT25B	0	C	
GND	GND0	0			GND	GND0	0		
A9	PT25A	0	T		A9	PT25A	0	T	
E12	PT24B	0	C		E12	PT24B	0	C	
B9	PT24A	0	T		B9	PT24A	0	T	
F11	PT23B	0	C		F11	PT23B	0	C	
A8	PT23A	0	T		A8	PT23A	0	T	
D11	PT22B	0	C		D11	PT22B	0	C	
C11	PT22A	0	T	TDQS22	C11	PT22A	0	T	TDQS22
B8	PT21B	0	C		B8	PT21B	0	C	
GND	GND0	0			GND	GND0	0		
B7	PT21A	0	T		B7	PT21A	0	T	
E11	PT20B	0	C		E11	PT20B	0	C	
A7	PT20A	0	T		A7	PT20A	0	T	
G11	PT19B	0	C		G11	PT19B	0	C	
C7	PT19A	0	T		C7	PT19A	0	T	
G10	PT18B	0	C		G10	PT18B	0	C	
C6	PT18A	0	T		C6	PT18A	0	T	
C10	PT17B	0	C		C10	PT17B	0	C	
GND	GND0	0			GND	GND0	0		
D10	PT17A	0	T		D10	PT17A	0	T	
F10	PT16B	0	C		F10	PT16B	0	C	
A6	PT16A	0	T		A6	PT16A	0	T	
E10	PT15B	0	C		E10	PT15B	0	C	
C9	PT15A	0	T		C9	PT15A	0	T	
G9	PT14B	0	C		G9	PT14B	0	C	
D9	PT14A	0	T	TDQS14	D9	PT14A	0	T	TDQS14

**LFECP/EC20, LFECP/EC33 Logic Signal Connections: 672 fpBGA (Cont.)**

LFEC20/LFECP20					LFECP/EC33				
Ball Number	Ball Function	Bank	LVDS	Dual Function	Ball Number	Ball Function	Bank	LVDS	Dual Function
A5	PT13B	0	C		A5	PT13B	0	C	
GND	GND0	0			GND	GND0	0		
A4	PT13A	0	T		A4	PT13A	0	T	
F9	PT12B	0	C		F9	PT12B	0	C	
B6	PT12A	0	T		B6	PT12A	0	T	
E9	PT11B	0	C		E9	PT11B	0	C	
C8	PT11A	0	T		C8	PT11A	0	T	
G8	PT10B	0	C		G8	PT10B	0	C	
B5	PT10A	0	T		B5	PT10A	0	T	
A3	PT9B	0	C		A3	PT9B	0	C	
GND	GND0	0			GND	GND0	0		
A2	PT9A	0	T		A2	PT9A	0	T	
F8	PT8B	0	C		F8	PT8B	0	C	
B4	PT8A	0	T		B4	PT8A	0	T	
E8	PT7B	0	C		E8	PT7B	0	C	
B3	PT7A	0	T		B3	PT7A	0	T	
D8	PT6B	0	C		D8	PT6B	0	C	
G7	PT6A	0	T	TDQS6	G7	PT6A	0	T	TDQS6
C4	PT5B	0	C		C4	PT5B	0	C	
C5	PT5A	0	T		C5	PT5A	0	T	
E7	PT4B	0	C		E7	PT4B	0	C	
D4	PT4A	0	T		D4	PT4A	0	T	
F7	PT3B	0	C		F7	PT3B	0	C	
D6	PT3A	0	T		D6	PT3A	0	T	
D7	PT2B	0	C		D7	PT2B	0	C	
E6	PT2A	0	T		E6	PT2A	0	T	
GND	GND0	0			GND	GND0	0		
K10	GND	-			K10	GND	-		
K11	GND	-			K11	GND	-		
K12	GND	-			K12	GND	-		
K13	GND	-			K13	GND	-		
K14	GND	-			K14	GND	-		
K15	GND	-			K15	GND	-		
K16	GND	-			K16	GND	-		
L10	GND	-			L10	GND	-		
L11	GND	-			L11	GND	-		
L12	GND	-			L12	GND	-		
L13	GND	-			L13	GND	-		
L14	GND	-			L14	GND	-		
L15	GND	-			L15	GND	-		
L16	GND	-			L16	GND	-		
L17	GND	-			L17	GND	-		

**LFCEP/EC20, LFCEP/EC33 Logic Signal Connections: 672 fpBGA (Cont.)**

LFCEP/EC20					LFCEP/EC33				
Ball Number	Ball Function	Bank	LVDS	Dual Function	Ball Number	Ball Function	Bank	LVDS	Dual Function
M10	GND	-			M10	GND	-		
M11	GND	-			M11	GND	-		
M12	GND	-			M12	GND	-		
M13	GND	-			M13	GND	-		
M14	GND	-			M14	GND	-		
M15	GND	-			M15	GND	-		
M16	GND	-			M16	GND	-		
M17	GND	-			M17	GND	-		
N10	GND	-			N10	GND	-		
N11	GND	-			N11	GND	-		
N12	GND	-			N12	GND	-		
N13	GND	-			N13	GND	-		
N14	GND	-			N14	GND	-		
N15	GND	-			N15	GND	-		
N16	GND	-			N16	GND	-		
N17	GND	-			N17	GND	-		
P10	GND	-			P10	GND	-		
P11	GND	-			P11	GND	-		
P12	GND	-			P12	GND	-		
P13	GND	-			P13	GND	-		
P14	GND	-			P14	GND	-		
P15	GND	-			P15	GND	-		
P16	GND	-			P16	GND	-		
P17	GND	-			P17	GND	-		
R10	GND	-			R10	GND	-		
R11	GND	-			R11	GND	-		
R12	GND	-			R12	GND	-		
R13	GND	-			R13	GND	-		
R14	GND	-			R14	GND	-		
R15	GND	-			R15	GND	-		
R16	GND	-			R16	GND	-		
R17	GND	-			R17	GND	-		
T10	GND	-			T10	GND	-		
T11	GND	-			T11	GND	-		
T12	GND	-			T12	GND	-		
T13	GND	-			T13	GND	-		
T14	GND	-			T14	GND	-		
T15	GND	-			T15	GND	-		
T16	GND	-			T16	GND	-		
T17	GND	-			T17	GND	-		
U10	GND	-			U10	GND	-		
U11	GND	-			U11	GND	-		

**LFCEP/EC20, LFCEP/EC33 Logic Signal Connections: 672 fpBGA (Cont.)**

LFCEP/EC20					LFCEP/EC33				
Ball Number	Ball Function	Bank	LVDS	Dual Function	Ball Number	Ball Function	Bank	LVDS	Dual Function
U12	GND	-			U12	GND	-		
U13	GND	-			U13	GND	-		
U14	GND	-			U14	GND	-		
U15	GND	-			U15	GND	-		
U16	GND	-			U16	GND	-		
U17	GND	-			U17	GND	-		
H10	VCC	-			H10	VCC	-		
H11	VCC	-			H11	VCC	-		
H16	VCC	-			H16	VCC	-		
H17	VCC	-			H17	VCC	-		
H18	VCC	-			H18	VCC	-		
H19	VCC	-			H19	VCC	-		
H8	VCC	-			H8	VCC	-		
H9	VCC	-			H9	VCC	-		
J18	VCC	-			J18	VCC	-		
J9	VCC	-			J9	VCC	-		
K8	VCC	-			K8	VCC	-		
L19	VCC	-			L19	VCC	-		
M19	VCC	-			M19	VCC	-		
N7	VCC	-			N7	VCC	-		
R20	VCC	-			R20	VCC	-		
R7	VCC	-			R7	VCC	-		
T19	VCC	-			T19	VCC	-		
V18	VCC	-			V18	VCC	-		
V8	VCC	-			V8	VCC	-		
V9	VCC	-			V9	VCC	-		
W10	VCC	-			W10	VCC	-		
W11	VCC	-			W11	VCC	-		
W16	VCC	-			W16	VCC	-		
W17	VCC	-			W17	VCC	-		
W18	VCC	-			W18	VCC	-		
W19	VCC	-			W19	VCC	-		
W8	VCC	-			W8	VCC	-		
W9	VCC	-			W9	VCC	-		
H12	VCCIO0	0			H12	VCCIO0	0		
H13	VCCIO0	0			H13	VCCIO0	0		
J10	VCCIO0	0			J10	VCCIO0	0		
J11	VCCIO0	0			J11	VCCIO0	0		
J12	VCCIO0	0			J12	VCCIO0	0		
J13	VCCIO0	0			J13	VCCIO0	0		
H14	VCCIO1	1			H14	VCCIO1	1		
H15	VCCIO1	1			H15	VCCIO1	1		

**LFCEP/EC20, LFCEP/EC33 Logic Signal Connections: 672 fpBGA (Cont.)**

LFCEP/EC20					LFCEP/EC33				
Ball Number	Ball Function	Bank	LVDS	Dual Function	Ball Number	Ball Function	Bank	LVDS	Dual Function
J14	VCCIO1	1			J14	VCCIO1	1		
J15	VCCIO1	1			J15	VCCIO1	1		
J16	VCCIO1	1			J16	VCCIO1	1		
J17	VCCIO1	1			J17	VCCIO1	1		
K17	VCCIO2	2			K17	VCCIO2	2		
K18	VCCIO2	2			K18	VCCIO2	2		
L18	VCCIO2	2			L18	VCCIO2	2		
M18	VCCIO2	2			M18	VCCIO2	2		
N18	VCCIO2	2			N18	VCCIO2	2		
N19	VCCIO2	2			N19	VCCIO2	2		
P18	VCCIO3	3			P18	VCCIO3	3		
P19	VCCIO3	3			P19	VCCIO3	3		
R18	VCCIO3	3			R18	VCCIO3	3		
R19	VCCIO3	3			R19	VCCIO3	3		
T18	VCCIO3	3			T18	VCCIO3	3		
U18	VCCIO3	3			U18	VCCIO3	3		
V14	VCCIO4	4			V14	VCCIO4	4		
V15	VCCIO4	4			V15	VCCIO4	4		
V16	VCCIO4	4			V16	VCCIO4	4		
V17	VCCIO4	4			V17	VCCIO4	4		
W14	VCCIO4	4			W14	VCCIO4	4		
W15	VCCIO4	4			W15	VCCIO4	4		
V10	VCCIO5	5			V10	VCCIO5	5		
V11	VCCIO5	5			V11	VCCIO5	5		
V12	VCCIO5	5			V12	VCCIO5	5		
V13	VCCIO5	5			V13	VCCIO5	5		
W12	VCCIO5	5			W12	VCCIO5	5		
W13	VCCIO5	5			W13	VCCIO5	5		
P8	VCCIO6	6			P8	VCCIO6	6		
P9	VCCIO6	6			P9	VCCIO6	6		
R8	VCCIO6	6			R8	VCCIO6	6		
R9	VCCIO6	6			R9	VCCIO6	6		
T9	VCCIO6	6			T9	VCCIO6	6		
U9	VCCIO6	6			U9	VCCIO6	6		
K9	VCCIO7	7			K9	VCCIO7	7		
L9	VCCIO7	7			L9	VCCIO7	7		
M8	VCCIO7	7			M8	VCCIO7	7		
M9	VCCIO7	7			M9	VCCIO7	7		
N8	VCCIO7	7			N8	VCCIO7	7		
N9	VCCIO7	7			N9	VCCIO7	7		
G13	VCCAUX	-			G13	VCCAUX	-		
H20	VCCAUX	-			H20	VCCAUX	-		



**LFECP/EC20, LFECP/EC33 Logic Signal Connections: 672 fpBGA (Cont.)**

LFEC20/LFECP20					LFECP/EC33				
Ball Number	Ball Function	Bank	LVDS	Dual Function	Ball Number	Ball Function	Bank	LVDS	Dual Function
H7	VCCAUX	-			H7	VCCAUX	-		
J19	VCCAUX	-			J19	VCCAUX	-		
J8	VCCAUX	-			J8	VCCAUX	-		
K7	VCCAUX	-			K7	VCCAUX	-		
L20	VCCAUX	-			L20	VCCAUX	-		
M20	VCCAUX	-			M20	VCCAUX	-		
M7	VCCAUX	-			M7	VCCAUX	-		
N20	VCCAUX	-			N20	VCCAUX	-		
P20	VCCAUX	-			P20	VCCAUX	-		
P7	VCCAUX	-			P7	VCCAUX	-		
T20	VCCAUX	-			T20	VCCAUX	-		
T7	VCCAUX	-			T7	VCCAUX	-		
T8	VCCAUX	-			T8	VCCAUX	-		
V19	VCCAUX	-			V19	VCCAUX	-		
V7	VCCAUX	-			V7	VCCAUX	-		
W20	VCCAUX	-			W20	VCCAUX	-		
Y13	VCCAUX	-			Y13	VCCAUX	-		
Y7	VCCAUX	-			Y7	VCCAUX	-		
K19	VCC <sup>1</sup>	-			K19	VCCPLL	-		
L8	VCC <sup>1</sup>	-			L8	VCCPLL	-		
U19	VCC <sup>1</sup>	-			U19	VCCPLL	-		
U8	VCC <sup>1</sup>	-			U8	VCCPLL	-		

1. Tied to V<sub>CCPLL</sub>.

## Thermal Management

Thermal management is recommended as part of any sound FPGA design methodology. To assess the thermal characteristics of a system, Lattice specifies a maximum allowable junction temperature in all device data sheets. Designers must complete a thermal analysis of their specific design to ensure that the device and package do not exceed the junction temperature limits. Refer to the Thermal Management document to find the device/package specific thermal values.

### For Further Information

For further information regarding Thermal Management, refer to the following located on the Lattice website at [www.latticesemi.com](http://www.latticesemi.com).

- Thermal Management document
- Technical Note TN1052 - Power Estimation and Management for LatticeECP/EC and LatticeXP Devices
- Power Calculator tool included with Lattice's ispLEVER design tool, or as a standalone download from [www.latticesemi.com/software](http://www.latticesemi.com/software)

## Part Number Description

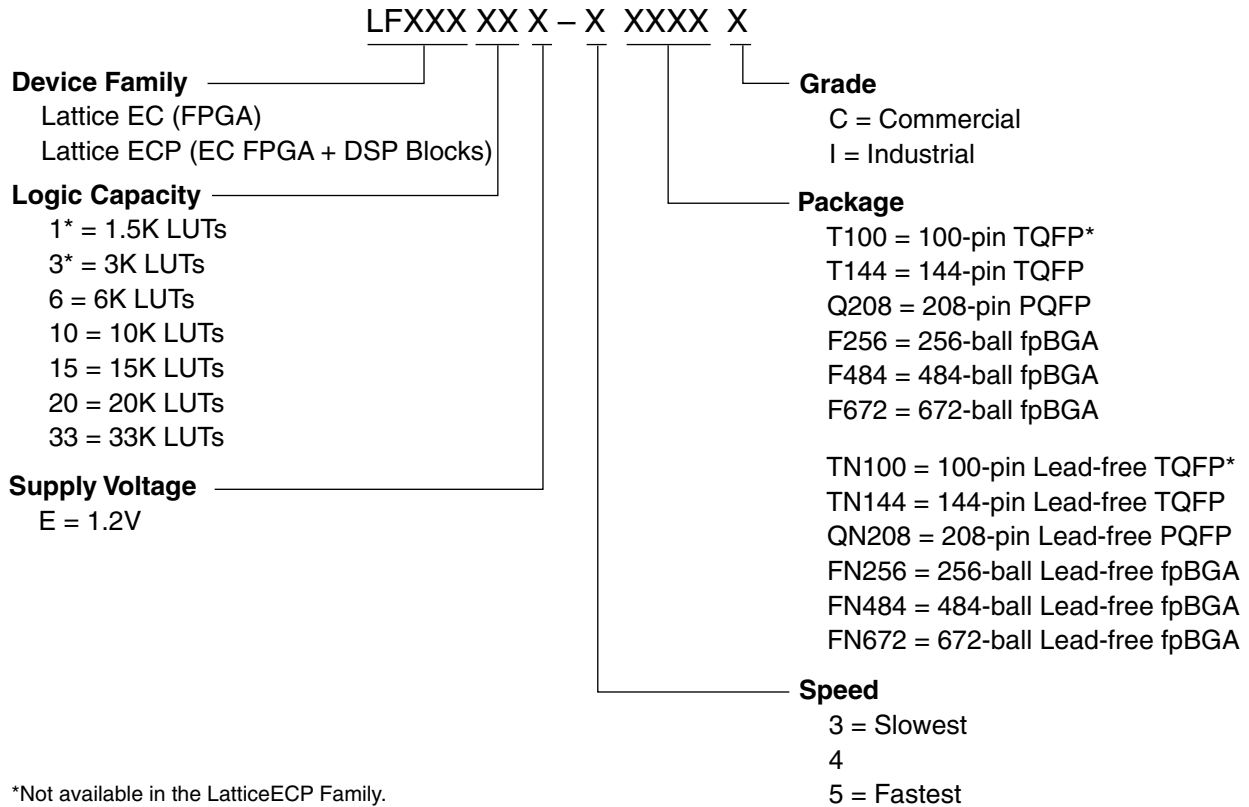

## Ordering Information

Note: LatticeECP/EC devices are dual marked. For example, the commercial speed grade LFEC20E-4F484C is also marked with industrial grade -3I (LFEC20E-3F484I). The commercial grade is one speed grade faster than the associated dual mark industrial grade. The slowest commercial speed grade does not have industrial markings. The markings appear as follows:

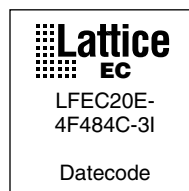

**Conventional Packaging****LatticeEC Commercial**

Part Number	I/Os	Grade	Package	Pins	Temp.	LUTs
LFEC1E-3Q208C	112	-3	PQFP	208	COM	1.5K
LFEC1E-4Q208C	112	-4	PQFP	208	COM	1.5K
LFEC1E-5Q208C	112	-5	PQFP	208	COM	1.5K
LFEC1E-3T144C	97	-3	TQFP	144	COM	1.5K
LFEC1E-4T144C	97	-4	TQFP	144	COM	1.5K
LFEC1E-5T144C	97	-5	TQFP	144	COM	1.5K
LFEC1E-3T100C	67	-3	TQFP	100	COM	1.5K
LFEC1E-4T100C	67	-4	TQFP	100	COM	1.5K
LFEC1E-5T100C	67	-5	TQFP	100	COM	1.5K

Part Number	I/Os	Grade	Package	Pins	Temp.	LUTs
LFEC3E-3F256C	160	-3	fpBGA	256	COM	3.1K
LFEC3E-4F256C	160	-4	fpBGA	256	COM	3.1K
LFEC3E-5F256C	160	-5	fpBGA	256	COM	3.1K
LFEC3E-3Q208C	145	-3	PQFP	208	COM	3.1K
LFEC3E-4Q208C	145	-4	PQFP	208	COM	3.1K
LFEC3E-5Q208C	145	-5	PQFP	208	COM	3.1K
LFEC3E-3T144C	97	-3	TQFP	144	COM	3.1K
LFEC3E-4T144C	97	-4	TQFP	144	COM	3.1K
LFEC3E-5T144C	97	-5	TQFP	144	COM	3.1K
LFEC3E-3T100C	67	-3	TQFP	100	COM	3.1K
LFEC3E-4T100C	67	-4	TQFP	100	COM	3.1K
LFEC3E-5T100C	67	-5	TQFP	100	COM	3.1K

Part Number	I/Os	Grade	Package	Pins	Temp.	LUTs
LFEC6E-3F484C	224	-3	fpBGA	484	COM	6.1K
LFEC6E-4F484C	224	-4	fpBGA	484	COM	6.1K
LFEC6E-5F484C	224	-5	fpBGA	484	COM	6.1K
LFEC6E-3F256C	195	-3	fpBGA	256	COM	6.1K
LFEC6E-4F256C	195	-4	fpBGA	256	COM	6.1K
LFEC6E-5F256C	195	-5	fpBGA	256	COM	6.1K
LFEC6E-3Q208C	147	-3	PQFP	208	COM	6.1K
LFEC6E-4Q208C	147	-4	PQFP	208	COM	6.1K
LFEC6E-5Q208C	147	-5	PQFP	208	COM	6.1K
LFEC6E-3T144C	97	-3	TQFP	144	COM	6.1K
LFEC6E-4T144C	97	-4	TQFP	144	COM	6.1K
LFEC6E-5T144C	97	-5	TQFP	144	COM	6.1K

Part Number	I/Os	Grade	Package	Pins	Temp.	LUTs
LFEC10E-3F484C	288	-3	fpBGA	484	COM	10.2K
LFEC10E-4F484C	288	-4	fpBGA	484	COM	10.2K
LFEC10E-5F484C	288	-5	fpBGA	484	COM	10.2K
LFEC10E-3F256C	195	-3	fpBGA	256	COM	10.2K

## LatticeEC Commercial (Continued)

Part Number	I/Os	Grade	Package	Pins	Temp.	LUTs
LFEC10E-4F256C	195	-4	fpBGA	256	COM	10.2K
LFEC10E-5F256C	195	-5	fpBGA	256	COM	10.2K
LFEC10E-3Q208C	147	-3	PQFP	208	COM	10.2K
LFEC10E-4Q208C	147	-4	PQFP	208	COM	10.2K
LFEC10E-5Q208C	147	-5	PQFP	208	COM	10.2K

Part Number	I/Os	Grade	Package	Pins	Temp.	LUTs
LFEC15E-3F484C	352	-3	fpBGA	484	COM	15.3K
LFEC15E-4F484C	352	-4	fpBGA	484	COM	15.3K
LFEC15E-5F484C	352	-5	fpBGA	484	COM	15.3K
LFEC15E-3F256C	195	-3	fpBGA	256	COM	15.3K
LFEC15E-4F256C	195	-4	fpBGA	256	COM	15.3K
LFEC15E-5F256C	195	-5	fpBGA	256	COM	15.3K

Part Number	I/Os	Grade	Package	Pins	Temp.	LUTs
LFEC20E-3F672C	400	-3	fpBGA	672	COM	19.7K
LFEC20E-4F672C	400	-4	fpBGA	672	COM	19.7K
LFEC20E-5F672C	400	-5	fpBGA	672	COM	19.7K
LFEC20E-3F484C	360	-3	fpBGA	484	COM	19.7K
LFEC20E-4F484C	360	-4	fpBGA	484	COM	19.7K
LFEC20E-5F484C	360	-5	fpBGA	484	COM	19.7K

Part Number	I/Os	Grade	Package	Pins	Temp.	LUTs
LFEC33E-3F672C	496	-3	fpBGA	672	COM	32.8K
LFEC33E-4F672C	496	-4	fpBGA	672	COM	32.8K
LFEC33E-5F672C	496	-5	fpBGA	672	COM	32.8K
LFEC33E-3F484C	360	-3	fpBGA	484	COM	32.8K
LFEC33E-4F484C	360	-4	fpBGA	484	COM	32.8K
LFEC33E-5F484C	360	-5	fpBGA	484	COM	32.8K

## LatticeECP Commercial

Part Number	I/Os	Grade	Package	Pins	Temp.	LUTs
LFCEP6E-3F484C	224	-3	fpBGA	484	COM	6.1K
LFCEP6E-4F484C	224	-4	fpBGA	484	COM	6.1K
LFCEP6E-5F484C	224	-5	fpBGA	484	COM	6.1K
LFCEP6E-3F256C	195	-3	fpBGA	256	COM	6.1K
LFCEP6E-4F256C	195	-4	fpBGA	256	COM	6.1K
LFCEP6E-5F256C	195	-5	fpBGA	256	COM	6.1K
LFCEP6E-3Q208C	147	-3	PQFP	208	COM	6.1K
LFCEP6E-4Q208C	147	-4	PQFP	208	COM	6.1K
LFCEP6E-5Q208C	147	-5	PQFP	208	COM	6.1K
LFCEP6E-3T144C	97	-3	TQFP	144	COM	6.1K
LFCEP6E-4T144C	97	-4	TQFP	144	COM	6.1K
LFCEP6E-5T144C	97	-5	TQFP	144	COM	6.1K

Part Number	I/Os	Grade	Package	Pins	Temp.	LUTs
LFCEP10E-3F484C	288	-3	fpBGA	484	COM	10.2K
LFCEP10E-4F484C	288	-4	fpBGA	484	COM	10.2K
LFCEP10E-5F484C	288	-5	fpBGA	484	COM	10.2K
LFCEP10E-3F256C	195	-3	fpBGA	256	COM	10.2K
LFCEP10E-4F256C	195	-4	fpBGA	256	COM	10.2K
LFCEP10E-5F256C	195	-5	fpBGA	256	COM	10.2K
LFCEP10E-3Q208C	147	-3	PQFP	208	COM	10.2K
LFCEP10E-4Q208C	147	-4	PQFP	208	COM	10.2K
LFCEP10E-5Q208C	147	-5	PQFP	208	COM	10.2K

Part Number	I/Os	Grade	Package	Pins	Temp.	LUTs
LFCEP15E-3F484C	352	-3	fpBGA	484	COM	15.3K
LFCEP15E-4F484C	352	-4	fpBGA	484	COM	15.3K
LFCEP15E-5F484C	352	-5	fpBGA	484	COM	15.3K
LFCEP15E-3F256C	195	-3	fpBGA	256	COM	15.3K
LFCEP15E-4F256C	195	-4	fpBGA	256	COM	15.3K
LFCEP15E-5F256C	195	-5	fpBGA	256	COM	15.3K

Part Number	I/Os	Grade	Package	Pins	Temp.	LUTs
LFCEP20E-3F672C	400	-3	fpBGA	672	COM	19.7K
LFCEP20E-4F672C	400	-4	fpBGA	672	COM	19.7K
LFCEP20E-5F672C	400	-5	fpBGA	672	COM	19.7K
LFCEP20E-3F484C	360	-3	fpBGA	484	COM	19.7K
LFCEP20E-4F484C	360	-4	fpBGA	484	COM	19.7K
LFCEP20E-5F484C	360	-5	fpBGA	484	COM	19.7K

Part Number	I/Os	Grade	Package	Pins	Temp.	LUTs
LFCEP33E-3F672C	496	-3	fpBGA	672	COM	32.8K
LFCEP33E-4F672C	496	-4	fpBGA	672	COM	32.8K
LFCEP33E-5F672C	496	-5	fpBGA	672	COM	32.8K

## LatticeECP Commercial (Continued)

Part Number	I/Os	Grade	Package	Pins	Temp.	LUTs
LFECP33E-3F484C	360	-3	fpBGA	484	COM	32.8K
LFECP33E-4F484C	360	-4	fpBGA	484	COM	32.8K
LFECP33E-5F484C	360	-5	fpBGA	484	COM	32.8K

## LatticeEC Industrial

Part Number	I/Os	Grade	Package	Pins	Temp.	LUTs
LFEC1E-3Q208I	112	-3	PQFP	208	IND	1.5K
LFEC1E-4Q208I	112	-4	PQFP	208	IND	1.5K
LFEC1E-3T144I	97	-3	TQFP	144	IND	1.5K
LFEC1E-4T144I	97	-4	TQFP	144	IND	1.5K
LFEC1E-3T100I	67	-3	TQFP	100	IND	1.5K
LFEC1E-4T100I	67	-4	TQFP	100	IND	1.5K

Part Number	I/Os	Grade	Package	Pins	Temp.	LUTs
LFEC3E-3F256I	160	-3	fpBGA	256	IND	3.1K
LFEC3E-4F256I	160	-4	fpBGA	256	IND	3.1K
LFEC3E-3Q208I	145	-3	PQFP	208	IND	3.1K
LFEC3E-4Q208I	145	-4	PQFP	208	IND	3.1K
LFEC3E-3T144I	97	-3	TQFP	144	IND	3.1K
LFEC3E-4T144I	97	-4	TQFP	144	IND	3.1K
LFEC3E-3T100I	67	-3	TQFP	100	IND	3.1K
LFEC3E-4T100I	67	-4	TQFP	100	IND	3.1K

Part Number	I/Os	Grade	Package	Pins	Temp.	LUTs
LFEC6E-3F484I	224	-3	fpBGA	484	IND	6.1K
LFEC6E-4F484I	224	-4	fpBGA	484	IND	6.1K
LFEC6E-3F256I	195	-3	fpBGA	256	IND	6.1K
LFEC6E-4F256I	195	-4	fpBGA	256	IND	6.1K
LFEC6E-3Q208I	147	-3	PQFP	208	IND	6.1K
LFEC6E-4Q208I	147	-4	PQFP	208	IND	6.1K
LFEC6E-3T144I	97	-3	TQFP	144	IND	6.1K
LFEC6E-4T144I	97	-4	TQFP	144	IND	6.1K

Part Number	I/Os	Grade	Package	Pins	Temp.	LUTs
LFEC10E-3F484I	288	-3	fpBGA	484	IND	10.2K
LFEC10E-4F484I	288	-4	fpBGA	484	IND	10.2K
LFEC10E-3F256I	195	-3	fpBGA	256	IND	10.2K
LFEC10E-4F256I	195	-4	fpBGA	256	IND	10.2K
LFEC10E-3 P208I	147	-3	PQFP	208	IND	10.2K
LFEC10E-4 P208I	147	-4	PQFP	208	IND	10.2K

## LatticeEC Industrial (Continued)

Part Number	I/Os	Grade	Package	Pins	Temp.	LUTs
LFEC15E-3F484I	352	-3	fpBGA	484	IND	15.3K
LFEC15E-4F484I	352	-4	fpBGA	484	IND	15.3K
LFEC15E-3F256I	195	-3	fpBGA	256	IND	15.3K
LFEC15E-4F256I	195	-4	fpBGA	256	IND	15.3K

Part Number	I/Os	Grade	Package	Pins	Temp.	LUTs
LFEC20E-3F672I	400	-3	fpBGA	672	IND	19.7K
LFEC20E-4F672I	400	-4	fpBGA	672	IND	19.7K
LFEC20E-3F484I	360	-3	fpBGA	484	IND	19.7K
LFEC20E-4F484I	360	-4	fpBGA	484	IND	19.7K

Part Number	I/Os	Grade	Package	Pins	Temp.	LUTs
LFEC33E-3F672I	496	-3	fpBGA	672	IND	32.8
LFEC33E-4F672I	496	-4	fpBGA	672	IND	32.8
LFEC33E-3F484I	360	-3	fpBGA	484	IND	32.8
LFEC33E-4F484I	360	-4	fpBGA	484	IND	32.8

## LatticeECP Industrial

Part Number	I/Os	Grade	Package	Pins	Temp.	LUTs
LFECP6E-3F484I	224	-3	fpBGA	484	IND	6.1K
LFECP6E-4F484I	224	-4	fpBGA	484	IND	6.1K
LFECP6E-3F256I	195	-3	fpBGA	256	IND	6.1K
LFECP6E-4F256I	195	-4	fpBGA	256	IND	6.1K
LFECP6E-3Q208I	147	-3	PQFP	208	IND	6.1K
LFECP6E-4Q208I	147	-4	PQFP	208	IND	6.1K
LFECP6E-3T144I	97	-3	TQFP	144	IND	6.1K
LFECP6E-4T144I	97	-4	TQFP	144	IND	6.1K

Part Number	I/Os	Grade	Package	Pins	Temp.	LUTs
LFECP10E-3F484I	288	-3	fpBGA	484	IND	10.2K
LFECP10E-4F484I	288	-4	fpBGA	484	IND	10.2K
LFECP10E-3F256I	195	-3	fpBGA	256	IND	10.2K
LFECP10E-4F256I	195	-4	fpBGA	256	IND	10.2K
LFECP10E-3Q208I	147	-3	PQFP	208	IND	10.2K
LFECP10E-4Q208I	147	-4	PQFP	208	IND	10.2K

Part Number	I/Os	Grade	Package	Pins	Temp.	LUTs
LFECP15E-3F484I	352	-3	fpBGA	484	IND	15.3K
LFECP15E-4F484I	352	-4	fpBGA	484	IND	15.3K
LFECP15E-3F256I	195	-3	fpBGA	256	IND	15.3K
LFECP15E-4F256I	195	-4	fpBGA	256	IND	15.3K



---

**LatticeECP Industrial (Continued)**

<b>Part Number</b>	<b>I/Os</b>	<b>Grade</b>	<b>Package</b>	<b>Pins</b>	<b>Temp.</b>	<b>LUTs</b>
LFCEP20E-3F672I	400	-3	fpBGA	672	IND	19.7K
LFCEP20E-4F672I	400	-4	fpBGA	672	IND	19.7K
LFCEP20E-3F484I	360	-3	fpBGA	484	IND	19.7K
LFCEP20E-4F484I	360	-4	fpBGA	484	IND	19.7K

<b>Part Number</b>	<b>I/Os</b>	<b>Grade</b>	<b>Package</b>	<b>Pins</b>	<b>Temp.</b>	<b>LUTs</b>
LFCEP33E-3F672I	496	-3	fpBGA	672	IND	32.8K
LFCEP33E-4F672I	496	-4	fpBGA	672	IND	32.8K
LFCEP33E-3F484I	360	-3	fpBGA	484	IND	32.8K
LFCEP33E-4F484I	360	-4	fpBGA	484	IND	32.8K

**Lead-Free Packaging****LatticeEC Commercial**

Part Number	I/Os	Grade	Package	Pins/Balls	Temp.	LUTs
LFEC1E-3QN208C	112	-3	Lead-Free PQFP	208	COM	1.5K
LFEC1E-4QN208C	112	-4	Lead-Free PQFP	208	COM	1.5K
LFEC1E-5QN208C	112	-5	Lead-Free PQFP	208	COM	1.5K
LFEC1E-3TN144C	97	-3	Lead-Free TQFP	144	COM	1.5K
LFEC1E-4TN144C	97	-4	Lead-Free TQFP	144	COM	1.5K
LFEC1E-5TN144C	97	-5	Lead-Free TQFP	144	COM	1.5K
LFEC1E-3TN100C	67	-3	Lead-Free TQFP	100	COM	1.5K
LFEC1E-4TN100C	67	-4	Lead-Free TQFP	100	COM	1.5K
LFEC1E-5TN100C	67	-5	Lead-Free TQFP	100	COM	1.5K

Part Number	I/Os	Grade	Package	Pins/Balls	Temp.	LUTs
LFEC3E-3FN256C	160	-3	Lead-Free fpBGA	256	COM	3.1K
LFEC3E-4FN256C	160	-4	Lead-Free fpBGA	256	COM	3.1K
LFEC3E-5FN256C	160	-5	Lead-Free fpBGA	256	COM	3.1K
LFEC3E-3QN208C	145	-3	Lead-Free PQFP	208	COM	3.1K
LFEC3E-4QN208C	145	-4	Lead-Free PQFP	208	COM	3.1K
LFEC3E-5QN208C	145	-5	Lead-Free PQFP	208	COM	3.1K
LFEC3E-3TN144C	97	-3	Lead-Free TQFP	144	COM	3.1K
LFEC3E-4TN144C	97	-4	Lead-Free TQFP	144	COM	3.1K
LFEC3E-5TN144C	97	-5	Lead-Free TQFP	144	COM	3.1K
LFEC3E-3TN100C	67	-3	Lead-Free TQFP	100	COM	3.1K
LFEC3E-4TN100C	67	-4	Lead-Free TQFP	100	COM	3.1K
LFEC3E-5TN100C	67	-5	Lead-Free TQFP	100	COM	3.1K

Part Number	I/Os	Grade	Package	Pins/Balls	Temp.	LUTs
LFEC6E-3FN484C	224	-3	Lead-Free fpBGA	484	COM	6.1K
LFEC6E-4FN484C	224	-4	Lead-Free fpBGA	484	COM	6.1K
LFEC6E-5FN484C	224	-5	Lead-Free fpBGA	484	COM	6.1K
LFEC6E-3FN256C	195	-3	Lead-Free fpBGA	256	COM	6.1K
LFEC6E-4FN256C	195	-4	Lead-Free fpBGA	256	COM	6.1K
LFEC6E-5FN256C	195	-5	Lead-Free fpBGA	256	COM	6.1K
LFEC6E-3QN208C	147	-3	Lead-Free PQFP	208	COM	6.1K
LFEC6E-4QN208C	147	-4	Lead-Free PQFP	208	COM	6.1K
LFEC6E-5QN208C	147	-5	Lead-Free PQFP	208	COM	6.1K
LFEC6E-3TN144C	97	-3	Lead-Free TQFP	144	COM	6.1K
LFEC6E-4TN144C	97	-4	Lead-Free TQFP	144	COM	6.1K
LFEC6E-5TN144C	97	-5	Lead-Free TQFP	144	COM	6.1K

Part Number	I/Os	Grade	Package	Pins/Balls	Temp.	LUTs
LFEC10E-3FN484C	288	-3	Lead-Free fpBGA	484	COM	10.2K
LFEC10E-4FN484C	288	-4	Lead-Free fpBGA	484	COM	10.2K
LFEC10E-5FN484C	288	-5	Lead-Free fpBGA	484	COM	10.2K
LFEC10E-3FN256C	195	-3	Lead-Free fpBGA	256	COM	10.2K

## LatticeEC Commercial (Continued)

Part Number	I/Os	Grade	Package	Pins/Balls	Temp.	LUTs
LFEC10E-4FN256C	195	-4	Lead-Free fpBGA	256	COM	10.2K
LFEC10E-5FN256C	195	-5	Lead-Free fpBGA	256	COM	10.2K
LFEC10E-3QN208C	147	-3	Lead-Free PQFP	208	COM	10.2K
LFEC10E-4QN208C	147	-4	Lead-Free PQFP	208	COM	10.2K
LFEC10E-5QN208C	147	-5	Lead-Free PQFP	208	COM	10.2K

Part Number	I/Os	Grade	Package	Pins/Balls	Temp.	LUTs
LFEC15E-3FN484C	352	-3	Lead-Free fpBGA	484	COM	15.3K
LFEC15E-4FN484C	352	-4	Lead-Free fpBGA	484	COM	15.3K
LFEC15E-5FN484C	352	-5	Lead-Free fpBGA	484	COM	15.3K
LFEC15E-3FN256C	195	-3	Lead-Free fpBGA	256	COM	15.3K
LFEC15E-4FN256C	195	-4	Lead-Free fpBGA	256	COM	15.3K
LFEC15E-5FN256C	195	-5	Lead-Free fpBGA	256	COM	15.3K

Part Number	I/Os	Grade	Package	Pins/Balls	Temp.	LUTs
LFEC20E-3FN672C	400	-3	Lead-Free fpBGA	672	COM	19.7K
LFEC20E-4FN672C	400	-4	Lead-Free fpBGA	672	COM	19.7K
LFEC20E-5FN672C	400	-5	Lead-Free fpBGA	672	COM	19.7K
LFEC20E-3FN484C	400	-3	Lead-Free fpBGA	484	COM	19.7K
LFEC20E-4FN484C	400	-4	Lead-Free fpBGA	484	COM	19.7K
LFEC20E-5FN484C	400	-5	Lead-Free fpBGA	484	COM	19.7K

Part Number	I/Os	Grade	Package	Pins/Balls	Temp.	LUTs
LFEC33E-3FN672C	496	-3	Lead-Free fpBGA	672	COM	32.8K
LFEC33E-4FN672C	496	-4	Lead-Free fpBGA	672	COM	32.8K
LFEC33E-5FN672C	496	-5	Lead-Free fpBGA	672	COM	32.8K
LFEC33E-3FN484C	360	-3	Lead-Free fpBGA	484	COM	32.8K
LFEC33E-4FN484C	360	-4	Lead-Free fpBGA	484	COM	32.8K
LFEC33E-5FN484C	360	-5	Lead-Free fpBGA	484	COM	32.8K

## LatticeECP Commercial

Part Number	I/Os	Grade	Package	Pins/Balls	Temp.	LUTs
LFCEP6E-3FN484C	224	-3	Lead-Free fpBGA	484	COM	6.1K
LFCEP6E-4FN484C	224	-4	Lead-Free fpBGA	484	COM	6.1K
LFCEP6E-5FN484C	224	-5	Lead-Free fpBGA	484	COM	6.1K
LFCEP6E-3FN256C	195	-3	Lead-Free fpBGA	256	COM	6.1K
LFCEP6E-4FN256C	195	-4	Lead-Free fpBGA	256	COM	6.1K
LFCEP6E-5FN256C	195	-5	Lead-Free fpBGA	256	COM	6.1K
LFCEP6E-3QN208C	147	-3	Lead-Free PQFP	208	COM	6.1K
LFCEP6E-4QN208C	147	-4	Lead-Free PQFP	208	COM	6.1K
LFCEP6E-5QN208C	147	-5	Lead-Free PQFP	208	COM	6.1K
LFCEP6E-3TN144C	97	-3	Lead-Free TQFP	144	COM	6.1K
LFCEP6E-4TN144C	97	-4	Lead-Free TQFP	144	COM	6.1K
LFCEP6E-5TN144C	97	-5	Lead-Free TQFP	144	COM	6.1K

Part Number	I/Os	Grade	Package	Pins/Balls	Temp.	LUTs
LFCEP10E-3FN484C	288	-3	Lead-Free fpBGA	484	COM	10.2K
LFCEP10E-4FN484C	288	-4	Lead-Free fpBGA	484	COM	10.2K
LFCEP10E-5FN484C	288	-5	Lead-Free fpBGA	484	COM	10.2K
LFCEP10E-3FN256C	195	-3	Lead-Free fpBGA	256	COM	10.2K
LFCEP10E-4FN256C	195	-4	Lead-Free fpBGA	256	COM	10.2K
LFCEP10E-5FN256C	195	-5	Lead-Free fpBGA	256	COM	10.2K
LFCEP10E-3QN208C	147	-3	Lead-Free PQFP	208	COM	10.2K
LFCEP10E-4QN208C	147	-4	Lead-Free PQFP	208	COM	10.2K
LFCEP10E-5QN208C	147	-5	Lead-Free PQFP	208	COM	10.2K

Part Number	I/Os	Grade	Package	Pins/Balls	Temp.	LUTs
LFCEP15E-3FN484C	352	-3	Lead-Free fpBGA	484	COM	15.3K
LFCEP15E-4FN484C	352	-4	Lead-Free fpBGA	484	COM	15.3K
LFCEP15E-5FN484C	352	-5	Lead-Free fpBGA	484	COM	15.3K
LFCEP15E-3FN256C	195	-3	Lead-Free fpBGA	256	COM	15.3K
LFCEP15E-4FN256C	195	-4	Lead-Free fpBGA	256	COM	15.3K
LFCEP15E-5FN256C	195	-5	Lead-Free fpBGA	256	COM	15.3K

Part Number	I/Os	Grade	Package	Pins/Balls	Temp.	LUTs
LFCEP20E-3FN672C	400	-3	Lead-Free fpBGA	672	COM	19.7K
LFCEP20E-4FN672C	400	-4	Lead-Free fpBGA	672	COM	19.7K
LFCEP20E-5FN672C	400	-5	Lead-Free fpBGA	672	COM	19.7K
LFCEP20E-3FN484C	400	-3	Lead-Free fpBGA	484	COM	19.7K
LFCEP20E-4FN484C	400	-4	Lead-Free fpBGA	484	COM	19.7K
LFCEP20E-5FN484C	400	-5	Lead-Free fpBGA	484	COM	19.7K

Part Number	I/Os	Grade	Package	Pins/Balls	Temp.	LUTs
LFCEP33E-3FN672C	496	-3	Lead-Free fpBGA	672	COM	32.8K
LFCEP33E-4FN672C	496	-4	Lead-Free fpBGA	672	COM	32.8K
LFCEP33E-5FN672C	496	-5	Lead-Free fpBGA	672	COM	32.8K

## LatticeECP Commercial (Continued)

Part Number	I/Os	Grade	Package	Pins/Balls	Temp.	LUTs
LFECP33E-3FN484C	360	-3	Lead-Free fpBGA	484	COM	32.8K
LFECP33E-4FN484C	360	-4	Lead-Free fpBGA	484	COM	32.8K
LFECP33E-5FN484C	360	-5	Lead-Free fpBGA	484	COM	32.8K

## LatticeEC Industrial

Part Number	I/Os	Grade	Package	Pins/Balls	Temp.	LUTs
LFEC1E-3QN208I	112	-3	Lead-Free PQFP	208	IND	1.5K
LFEC1E-4QN208I	112	-4	Lead-Free PQFP	208	IND	1.5K
LFEC1E-3TN144I	97	-3	Lead-Free TQFP	144	IND	1.5K
LFEC1E-4TN144I	97	-4	Lead-Free TQFP	144	IND	1.5K
LFEC1E-3TN100I	67	-3	Lead-Free TQFP	100	IND	1.5K
LFEC1E-4TN100I	67	-4	Lead-Free TQFP	100	IND	1.5K

Part Number	I/Os	Grade	Package	Pins/Balls	Temp.	LUTs
LFEC3E-3FN256I	160	-3	Lead-Free fpBGA	256	IND	3.1K
LFEC3E-4FN256I	160	-4	Lead-Free fpBGA	256	IND	3.1K
LFEC3E-3QN208I	145	-3	Lead-Free PQFP	208	IND	3.1K
LFEC3E-4QN208I	145	-4	Lead-Free PQFP	208	IND	3.1K
LFEC3E-3TN144I	97	-3	Lead-Free TQFP	144	IND	3.1K
LFEC3E-4TN144I	97	-4	Lead-Free TQFP	144	IND	3.1K
LFEC3E-3TN100I	67	-3	Lead-Free TQFP	100	IND	3.1K
LFEC3E-4TN100I	67	-4	Lead-Free TQFP	100	IND	3.1K

Part Number	I/Os	Grade	Package	Pins/Balls	Temp.	LUTs
LFEC6E-3FN484I	224	-3	Lead-Free fpBGA	484	IND	6.1K
LFEC6E-4FN484I	224	-4	Lead-Free fpBGA	484	IND	6.1K
LFEC6E-3FN256I	195	-3	Lead-Free fpBGA	256	IND	6.1K
LFEC6E-4FN256I	195	-4	Lead-Free fpBGA	256	IND	6.1K
LFEC6E-3QN208I	147	-3	Lead-Free PQFP	208	IND	6.1K
LFEC6E-4QN208I	147	-4	Lead-Free PQFP	208	IND	6.1K
LFEC6E-3TN144I	97	-3	Lead-Free TQFP	144	IND	6.1K
LFEC6E-4TN144I	97	-4	Lead-Free TQFP	144	IND	6.1K

Part Number	I/Os	Grade	Package	Pins/Balls	Temp.	LUTs
LFEC10E-3FN484I	288	-3	Lead-Free fpBGA	484	IND	10.2K
LFEC10E-4FN484I	288	-4	Lead-Free fpBGA	484	IND	10.2K
LFEC10E-3FN256I	195	-3	Lead-Free fpBGA	256	IND	10.2K
LFEC10E-4FN256I	195	-4	Lead-Free fpBGA	256	IND	10.2K
LFEC10E-3QN208I	147	-3	Lead-Free PQFP	208	IND	10.2K
LFEC10E-4QN208I	147	-4	Lead-Free PQFP	208	IND	10.2K

## LatticeEC Industrial (Continued)

Part Number	I/Os	Grade	Package	Pins/Balls	Temp.	LUTs
LFEC15E-3FN484I	352	-3	Lead-Free fpBGA	484	IND	15.3K
LFEC15E-4FN484I	352	-4	Lead-Free fpBGA	484	IND	15.3K
LFEC15E-3FN256I	195	-3	Lead-Free fpBGA	256	IND	15.3K
LFEC15E-4FN256I	195	-4	Lead-Free fpBGA	256	IND	15.3K

Part Number	I/Os	Grade	Package	Pins/Balls	Temp.	LUTs
LFEC20E-3FN672I	400	-3	Lead-Free fpBGA	672	IND	19.7K
LFEC20E-4FN672I	400	-4	Lead-Free fpBGA	672	IND	19.7K
LFEC20E-3FN484I	400	-3	Lead-Free fpBGA	484	IND	19.7K
LFEC20E-4FN484I	400	-4	Lead-Free fpBGA	484	IND	19.7K

Part Number	I/Os	Grade	Package	Pins/Balls	Temp.	LUTs
LFEC33E-3FN672I	496	-3	Lead-Free fpBGA	672	IND	32.8K
LFEC33E-4FN672I	496	-4	Lead-Free fpBGA	672	IND	32.8K
LFEC33E-3FN484I	360	-3	Lead-Free fpBGA	484	IND	32.8K
LFEC33E-4FN484I	360	-4	Lead-Free fpBGA	484	IND	32.8K

## LatticeECP Industrial

Part Number	I/Os	Grade	Package	Pins/Balls	Temp.	LUTs
LFEC6E-3FN484I	224	-3	Lead-Free fpBGA	484	IND	6.1K
LFEC6E-4FN484I	224	-4	Lead-Free fpBGA	484	IND	6.1K
LFEC6E-3FN256I	195	-3	Lead-Free fpBGA	256	IND	6.1K
LFEC6E-4FN256I	195	-4	Lead-Free fpBGA	256	IND	6.1K
LFEC6E-3QN208I	147	-3	Lead-Free PQFP	208	IND	6.1K
LFEC6E-4QN208I	147	-4	Lead-Free PQFP	208	IND	6.1K
LFEC6E-3TN144I	97	-3	Lead-Free TQFP	144	IND	6.1K
LFEC6E-4TN144I	97	-4	Lead-Free TQFP	144	IND	6.1K

Part Number	I/Os	Grade	Package	Pins/Balls	Temp.	LUTs
LFEC10E-3FN484I	288	-3	Lead-Free fpBGA	484	IND	10.2K
LFEC10E-4FN484I	288	-4	Lead-Free fpBGA	484	IND	10.2K
LFEC10E-3FN256I	195	-3	Lead-Free fpBGA	256	IND	10.2K
LFEC10E-4FN256I	195	-4	Lead-Free fpBGA	256	IND	10.2K
LFEC10E-3QN208I	147	-3	Lead-Free PQFP	208	IND	10.2K
LFEC10E-4QN208I	147	-4	Lead-Free PQFP	208	IND	10.2K

Part Number	I/Os	Grade	Package	Pins/Balls	Temp.	LUTs
LFEC15E-3FN484I	352	-3	Lead-Free fpBGA	484	IND	15.3K
LFEC15E-4FN484I	352	-4	Lead-Free fpBGA	484	IND	15.3K
LFEC15E-3FN256I	195	-3	Lead-Free fpBGA	256	IND	15.3K
LFEC15E-4FN256I	195	-4	Lead-Free fpBGA	256	IND	15.3K

---

**LatticeECP Industrial (Continued)**

<b>Part Number</b>	<b>I/Os</b>	<b>Grade</b>	<b>Package</b>	<b>Pins/Balls</b>	<b>Temp.</b>	<b>LUTs</b>
LFCEP20E-3FN672I	400	-3	Lead-Free fpBGA	672	IND	19.7K
LFCEP20E-4FN672I	400	-4	Lead-Free fpBGA	672	IND	19.7K
LFCEP20E-3FN484I	400	-3	Lead-Free fpBGA	484	IND	19.7K
LFCEP20E-4FN484I	400	-4	Lead-Free fpBGA	484	IND	19.7K

<b>Part Number</b>	<b>I/Os</b>	<b>Grade</b>	<b>Package</b>	<b>Pins/Balls</b>	<b>Temp.</b>	<b>LUTs</b>
LFCEP33E-3FN672I	496	-3	Lead-Free fpBGA	672	IND	32.8K
LFCEP33E-4FN672I	496	-4	Lead-Free fpBGA	672	IND	32.8K
LFCEP33E-3FN484I	360	-3	Lead-Free fpBGA	484	IND	32.8K
LFCEP33E-4FN484I	360	-4	Lead-Free fpBGA	484	IND	32.8K

## For Further Information

A variety of technical notes for the LatticeECP/EC family are available on the Lattice web site at [www.latticesemi.com](http://www.latticesemi.com).

- LatticeECP/EC sysIO Usage Guide (TN1056)
- LatticeECP/EC sysCLOCK PLL Design and Usage Guide (TN1049)
- Memory Usage Guide for LatticeECP/EC Devices (TN1051)
- LatticeECP/EC DDR Usage Guide (TN1050)
- Power Estimation and Management for LatticeECP/EC and LatticeXP Devices (TN1052)
- LatticeECP-DSP sysDSP Usage Guide (TN1057)
- LatticeECP/EC sysCONFIG Usage Guide (TN1053)
- IEEE 1149.1 Boundary Scan Testability in Lattice Devices

For further information about interface standards refer to the following web sites:

- JEDEC Standards (LVTTTL, LVCMOS, SSTL, HSTL): [www.jedec.org](http://www.jedec.org)
- PCI: [www.pcisig.com](http://www.pcisig.com)



### Revision History

Date	Version	Section	Change Summary
June 2004	01.0	—	Initial release.
August 2004	01.1	Introduction	Added new device LFEC33 in Table 1-1.
		Architecture	Added New device LFEC33 in Tables 2-9, 2-10 and 2-11.
		DC & Switching Characteristics	Added New device LFEC33 on Supply current (Standby) tables.
			Added New device LFEC33 on Initialization Supply current tables.
Ordering Information	Added 33K Logic Capacity Device in Part Number Description section.		
	Added EC33, ECP33 device: Industrial and Commercial to Part Number table.		
	Corrected I/O counts in the part number tables for 100/144 TQFP and 208 PQFP packages to match Table 1-1 on page 1.		
November 2004	01.3	Introduction	Changed DDR333 (166MHz) to DDR400 (200MHz)
			Added "RSDS" offering to the Features list: Flexible I/O Buffer
		Architecture	Added information about Secondary Clock Sources
			Added information about DCS
			Added a section on "Recommended Power-up Sequence"
			Updated Figure 2-24 "DQS Routing"
			Added DSP Block performance numbers to Table 2-11
			Added another row for RSDS in Table 2-13 and Table 2-14
		DC & Switching Characteristics	Updated new timing numbers
			Added numbers to derating table
			Added DC conditions to RSDS table
			Changed LVDS Max. $V_{CCIO}$ to 2.625
			Added a row for RSDS in "Operating Condition" table
			Updated standby and initialization current table
			Added figure 3-12: sysConfig SPI port sequence
			Added DDR Timing Table and DDR Timings Figure 3-6
		Pinout Information	Added LFEC33/EC6 to Pin Information
			Added LFEC33/EC6 to Power Supply and NC Connections
			Added LFEC33/EC6 144 TQFP Logic Signal Connections
			Added LFEC33/EC6 208 PQFP Logic Signal Connections
			Added LFEC33/EC6 256 fpBGA Logic Signal Connections
			Added LFEC33/EC6 484 fpBGA Logic Signal Connections
		Ordering Information	Added 33K Logic Capacity Device in Part Number Description section.
			Added Part Number table for Commercial EC33.
Added Part Number table for Commercial ECP33.			
Added Part Number table for Industrial ECP33.			

Date	Version	Section	Change Summary
December 2004	01.4	Architecture	Updated Hot Socketing Recommended Power Up Sequence section.
		Pinout Information	Added LFEC1, LFEC3, LFECP/EC10, LFECP/EC15 to Pin Information
			Added LFEC1, LFEC3, LFECP/EC10, LFECP/EC15 to Power Supply and NC Connections
			Added LFEC1 and LFEC3 100 TQFP Pinout
			Added LFEC1 and LFEC3 144 TQFP Pinout
			Added LFEC1, LFEC3 and LFECP/EC10 208 PQFP Pinout
			Added LFEC3, LFECP/EC10 and LFECP/EC15 256 fpBGA Pinout
		Ordering Information	Added LFECP/EC10 and LFECP/EC15 484 fpBGA Pinout
			Added Lead-Free Package Designators
Supplemental Information	Updated list of technical notes.		
April 2005	01.5	Architecture	EBR memory support section has been updated with clarification.
			Updated sysIO buffer pair section.
		DC & Switching Characteristics	Hot Socketing Specification has been updated.
			DC Electrical Characteristics table ( $I_{IL}$ , $I_{IH}$ ) has been updated.
			Supply Current (Standby) table has been updated.
			Initialization Supply Current table has been updated.
			External Switching Characteristics section has been updated.
			Removed $t_{RSTW}$ spec. from PLL Parameter table.
			$t_{RST}$ specifications have been updated.
		sysCONFIG Port Timing Specifications ( $t_{BSCl}$ , $t_{ODISS}$ , $t_{PRGMRJ}$ ) have been updated.	
		Pinout Information	Added LFECP/EC33 Pinout Information
			Pin Information Summary table has been updated.
			Power Supply and NC Connection table has been updated.
			484-fpBGA logic connection has been updated (Ball # J6, J17, P6 and P17 for ECP/EC33 are now called VCCPLL).
672-fpBGA logic connection has been updated (Ball # K19, L8, U19, U8 for ECP/EC33 are now called VCCPLL).			
May 2005	01.6	Introduction	ECP/EC33 EBR SRAM Bits and Blocks have been updated to 498K and 54 respectively.
		Architecture	Table 2-10 has been updated (ECP/EC33 EBR SRAM Bits and Blocks have been updated to 498K and 54 respectively.)
			Recommended Power Up Sequence section has been removed.
		DC & Switching Characteristics	Supply Current (Standby) table has been updated.
			Initialization Supply Current table has been updated.
			Vos test condition has been updated to $(VOP+VOM)/2$ .
			Register-to-Register performance table has been updated (rev. G 0.27).
			External switching characteristics have been updated (rev. G 0.27).
			Internal timing parameters have been updated (rev. G 0.27).
			Timing adders have been updated (rev. G 0.27).
		sysCONFIG port timing specifications have been updated.	
		Pinout Information	Pin Information Summary table has been updated.
			Power Supply and NC Connection table has been updated.
		Ordering Information	OPN list has been updated.

Date	Version	Section	Change Summary
September 2005	02.0	Architecture	sysIO section has been updated.
		DC & Switching Characteristics	Recommended Operating Conditions has been updated with $V_{CCPLL}$ .
			DC Electrical Characteristics table has been updated
			Removed 5V Tolerant Input Buffer section.
			Register-to-Register performance table has been updated (rev. G 0.28).
			LatticeECP/EC External Switching Characteristics table has been updated (rev. G 0.28).
			LatticeECP/EC Internal Switching Characteristics table has been updated (rev. G 0.28).
			LatticeECP/EC Family Timing Adders have been updated (rev. G 0.28).
			sysCLOCK PLL timing table has been updated (rev. G 0.28)
			LatticeECP/EC sysCONFIG Port Timing specification table has been updated (rev. G 0.28).
			Master Clock table has been updated (rev. G 0.28).
JTAG Port Timing specification table has been updated (rev. G 0.28).			
Pinout Information	Signal Description table has been updated with $V_{CCPLL}$ .		
November 2005	02.1	DC & Switching Characteristics	Pin-to-Pin Performance table has been updated (G 0.30) - 4:1MUX, 8:1MUX, 16:1MUX, 32:1MUX Register-to-Register Performance (G 0.30) - No timing number changes.
			External Switching Characteristics (G 0.30) - No timing number changes.
			Internal Switching Characteristics (G 0.30) - $t_{SUP\_DSP}$ , $t_{HP\_DSP}$ , $t_{SUO\_DSP}$ , $t_{HO\_DSP}$ , $t_{COI\_DSP}$ , $t_{COD\_DSP}$ numbers have been updated.
			Family Timing Adders (G 0.30) - No timing number changes.
			sysCLOCK PLL Timing (G 0.30) - No timing number changes.
			sysCONFIG Port Timing Specifications (G 0.30) - No timing number changes.
			Master Clock (G 0.30) - No timing number changes.
			JTAG Port Timing Specification (G 0.30) - No timing number changes.
		Ordering Information	Added 208-PQFP lead-free part numbers.
March 2006	02.2	DC & Switching Characteristics	Added footnote 3. to $V_{CCAUX}$ in the Recommended Operating Conditions table.
January 2007	02.3	Architecture	EBR Asynchronous Reset section added.
February 2007	02.4	Architecture	Updated EBR Asynchronous Reset section.
			Updated Maximum Number of Elements in a Block table - MAC value for x9 changed to 2.
May 2007	02.5	Architecture	Updated text in Ripple Mode section.
November 2007	02.6	DC & Switching Characteristics	Added JTAG Port Waveforms diagram.
			Updated $t_{RST}$ timing information in the sysCLOCK PLL Timing table.
		Pinout Information	Added Thermal Management text section.
		Supplemental Information	Updated title list.
February 2008	02.7	DC & Switching Characteristics	Read/Write Mode (Normal) and Read/Write Mode with Input and Output Registers waveforms in the EBR Memory Timing Diagrams section have been updated.