

# LH28F016SU

16M (1M × 16, 2M × 8) Flash Memory

## FEATURES

- User-Configurable x8 or x16 Operation
- User-Selectable 3.3 V or 5 V  $V_{CC}$
- 70 ns Maximum Access Time
- 0.32 MB/sec Write Transfer Rate
- 100,000 Erase Cycles per Block
- 32 Independently Lockable Blocks
- 5 V Write/Erase Operation (5 V  $V_{PP}$ )
  - No Requirement for DC/DC Converter to Write/Erase
- Minimum 2.7 V Read capability
  - 160 ns Maximum Access Time ( $V_{CC} = 2.7 V$ )
- Revolutionary Architecture
  - Pipelined Command Execution
  - Write During Erase
  - Command Superset of Sharp LH28F008SA
- 5  $\mu A$  (Typ.)  $I_{CC}$  in CMOS Standby
- 1  $\mu A$  (Typ.) Deep Power-Down
- State-of-the-Art 0.55  $\mu m$  ETOX™ Flash Technology
- 56-Pin, 1.2 mm × 14 mm × 20 mm TSOP (Type I) Package

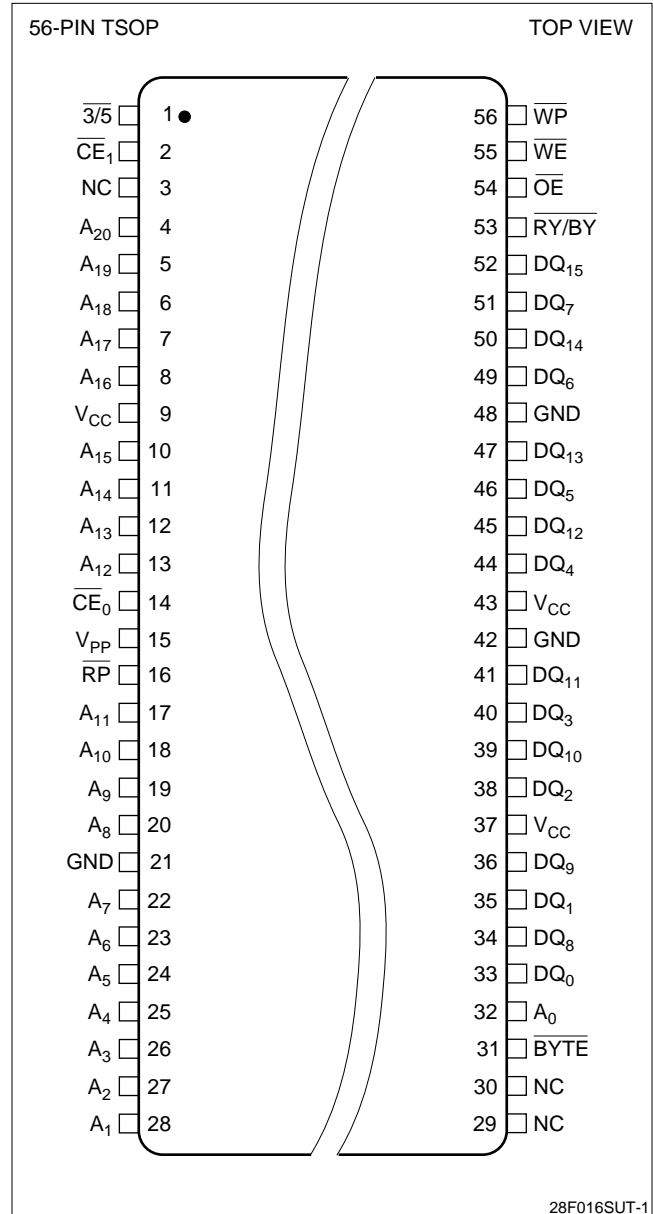


Figure 1. TSOP Configuration

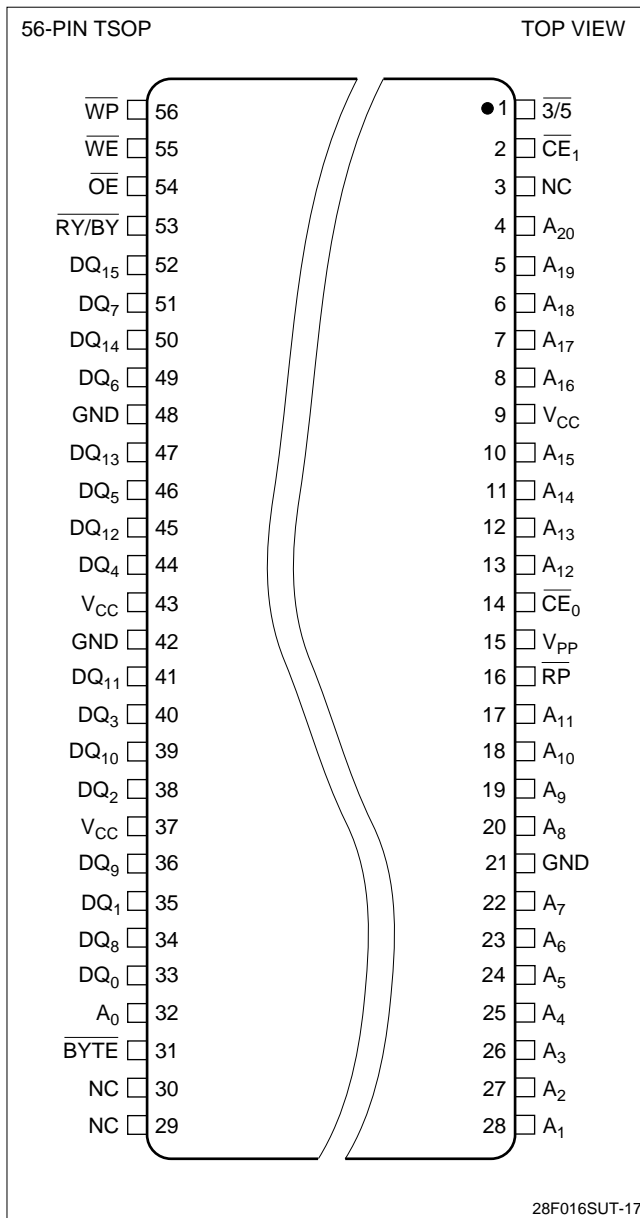


Figure 2. TSOP Reverse Bend Configuration

## INTRODUCTION

Sharp's LH28F016SU 16M Flash Memory is a revolutionary architecture which enables the design of truly mobile, high performance, personal computing and communication products. With innovative capabilities, 5 V single voltage operation and very high read/write performance, the LH28F016SU is also the ideal choice for designing embedded mass storage memory systems.

The LH28F016SU is a very high density, highest performance non-volatile read/write solution for solid-state storage applications. Its symmetrically blocked architecture (100% compatible with the LH28F008SA 8M Flash memory), extended cycling, low power 3.3 V operation, very fast write and read performance and selective block locking provide a highly flexible memory component suitable for high density memory cards, Resident Flash Arrays and PCMCIA-ATA Flash Drives. The LH28F016SU's dual read voltage enables the design of memory cards which can interchangeably be read/written in 3.3 V and 5.0 V systems. Its x8/x16 architecture allows the optimization of memory to processor interface. The flexible block locking option enables bundling of executable application software in a Resident Flash Array or memory card. Manufactured on Sharp's 0.55  $\mu\text{m}$  ETOX™ process technology, the LH28F016SU is the most cost-effective, high-density 3.3 V flash memory.

## DESCRIPTION

The LH28F016SU is a high performance 16M (16,777,216 bit) block erasable non-volatile random access memory organized as either 1M × 16 or 2M × 8. The LH28F016SU includes thirty-two 64K (65,536) blocks or thirty-two 32-KW (32,768) blocks. A chip memory map is shown in Figure 4.

The implementation of a new architecture, with many enhanced features, will improve the device operating characteristics and results in greater product reliability and ease of use.

Among the significant enhancements of the LH28F016SU:

- 5 V Write/Erase Operation (5 V  $V_{PP}$ )
- 3.3 V Low Power Capability (2.7 V  $V_{CC}$  Read)
- Improved Write Performance
- Dedicated Block Write/Erase Protection

A  $\overline{3/5}$  input pin reconfigures the device internally for optimized 3.3 V or 5.0 V read/write operation.

The LH28F016SU will be available in a 56-pin, 1.2 mm thick × 14 mm × 20 mm TSOP (Type I) package. This form factor and pinout allow for very high board layout densities.



## PIN DESCRIPTION

SYMBOL	TYPE	NAME AND FUNCTION
$A_0$	INPUT	<b>BYTE-SELECT ADDRESS:</b> Selects between high and low byte when device is in x8 mode. This address is latched in x8 Data Writes. Not used in x16 mode (i.e., the $A_0$ input buffer is turned off when $\overline{BYTE}$ is high).
$A_1 - A_{15}$	INPUT	<b>WORD-SELECT ADDRESSES:</b> Select a word within one 64K block. $A_6 - A_{15}$ selects 1 of 1024 rows, and $A_1 - A_5$ selects 16 of 512 columns. These addresses are latched during Data Writes.
$A_{16} - A_{20}$	INPUT	<b>BLOCK-SELECT ADDRESSES:</b> Select 1 of 32 Erase blocks. These addresses are latched during Data Writes, Erase and Lock-Block operations.
$DQ_0 - DQ_7$	INPUT/OUTPUT	<b>LOW-BYTE DATA BUS:</b> Inputs data and commands during CUI write cycles. Outputs array, buffer, identifier or status data in the appropriate Read mode. Floated when the chip is de-selected or the outputs are disabled.
$DQ_8 - DQ_{15}$	INPUT/OUTPUT	<b>HIGH-BYTE DATA BUS:</b> Inputs data during x16 Data-Write operations. Outputs array, buffer or identifier data in the appropriate Read mode; not used for Status register reads. Floated when the chip is de-selected or the outputs are disabled.
$\overline{CE}_0, \overline{CE}_1$	INPUT	<b>CHIP ENABLE INPUTS:</b> Activate the device's control logic, input buffers, decoders and sense amplifiers. With either $\overline{CE}_0$ or $\overline{CE}_1$ high, the device is de-selected and power consumption reduces to Standby levels upon completion of any current Data-Write or Erase operations. Both $\overline{CE}_0, \overline{CE}_1$ must be low to select the device. All timing specifications are the same for both signals. Device Selection occurs with the latter falling edge of $\overline{CE}_0$ or $\overline{CE}_1$ . The first rising edge of $\overline{CE}_0$ or $\overline{CE}_1$ disables the device.
$\overline{RP}$	INPUT	<b>RESET/POWER-DOWN:</b> With $\overline{RP}$ low, the device is reset, any current operation is aborted and device is put into the deep power down mode. When the power is turned on, $\overline{RP}$ pin is turned to low in order to return the device to default configuration. When the $\overline{3/5}$ pin is switched, or when the power transition is occurred, or at the power on/off, $\overline{RP}$ is required to stay low in order to protect data from noise. When returning from Deep Power-Down, a recovery time of 400 ns ( $V_{CC} +5.0\text{ V} \pm 0.5\text{ V}$ ) is required to allow these circuits to power-up. When $\overline{RP}$ goes low, any current or pending WSM operation(s) are terminated, and the device is reset. All Status registers return to ready (with all status flags cleared). After returning, the device is in read array mode.
$\overline{OE}$	INPUT	<b>OUTPUT ENABLE:</b> Gates device data through the output buffers when low. The outputs float to tri-state off when $\overline{OE}$ is high. <b>NOTE:</b> $\overline{CE}_X$ overrides $\overline{OE}$ , and $\overline{OE}$ overrides $\overline{WE}$ .
$\overline{WE}$	INPUT	<b>WRITE ENABLE:</b> Controls access to the CUI, Page Buffers, Data Queue Registers and Address Queue Latches. $\overline{WE}$ is active low, and latches both address and data (command or array) on its rising edge.
$\overline{RY}/\overline{BY}$	OPEN DRAIN OUTPUT	<b>READY/BUSY:</b> Indicates status of the internal WSM. When low, it indicates that the WSM is busy performing an operation. $\overline{RY}/\overline{BY}\#$ high indicates that the WSM is ready for new operations (or WSM has completed all pending operations), or Erase is Suspended, or the device is in deep power-down mode. This output is always active (i.e., not floated to tri-state off when $\overline{OE}$ or $\overline{CE}_0, \overline{CE}_1$ are high), except if a $\overline{RY}/\overline{BY}$ Pin Disable command is issued.

## PIN DESCRIPTION (Continued)

SYMBOL	TYPE	NAME AND FUNCTION
$\overline{WP}$	INPUT	<b>WRITE PROTECT:</b> Erase blocks can be locked by writing a non-volatile lock-bit for each block. When $\overline{WP}$ is low, those locked blocks as reflected by the Block-Lock Status bits (BSR.6), are protected from inadvertent Data Writes or Erases. When $\overline{WP}$ is high, all blocks can be Written or Erased regardless of the state of the lock-bits. The $\overline{WP}$ input buffer is disabled when $\overline{RP}$ transitions low (deep power-down mode).
$\overline{BYTE}$	INPUT	<b>BYTE ENABLE:</b> $\overline{BYTE}$ low places device x8 mode. All data is then input or output on $DQ_0 - DQ_7$ , and $DQ_8 - DQ_{15}$ float. Address $A_0$ selects between the high and low byte. $\overline{BYTE}$ high places the device in x16 mode, and turns off the $A_0$ input buffer. Address $A_1$ , then becomes the lowest order address.
$\overline{3/5}$	INPUT	<b>3.3/5.0 VOLT SELECT:</b> $\overline{3/5}$ high configures internal circuits for 3.3 V operation. $\overline{3/5}$ low configures internal circuits for 5.0 V operation. <b>NOTES:</b> Reading the array with $\overline{3/5}$ high in a 5.0 V system could damage the device. There is a significant delay from $\overline{3/5}$ switching to valid data.
$V_{PP}$	SUPPLY	<b>ERASE/WRITE POWER SUPPLY:</b> For erasing memory array blocks or writing words/bytes/pages into the flash array.
$V_{CC}$	SUPPLY	<b>DEVICE POWER SUPPLY (3.3 V ±0.3 V, 5.0 V ±0.5 V) (2.7 V ~ 3.6 V at Read Operation):</b> Do not leave any power pins floating.
GND	SUPPLY	<b>GROUND FOR ALL INTERNAL CIRCUITRY:</b> Do not leave any ground pins floating.
NC		<b>NO CONNECT:</b> No internal connection to die, lead may be driven or left floating.

A Command User Interface (CUI) serves as the system interface between the microprocessor or microcontroller and the internal memory operation.

Internal Algorithm Automation allows Byte/Word Writes and Block Erase operations to be executed using a Two-Write command sequence to the CUI in the same way as the LH28F008SA 8M Flash memory.

A Superset of commands have been added to the basic LH28F008SA command-set to achieve higher write performance and provide additional capabilities. These new commands and features include:

- Page Buffer Writes to Flash
- Command Queuing Capability
- Automatic Data Writes During Erase
- Software Locking of Memory Blocks
- Two-Byte Successive Writes in 8-bit Systems
- Erase All Unlocked Blocks

Writing of memory data is performed in either byte or word increments typically within 8  $\mu$ s, a 25% improvement over the LH28F008SA. A Block Erase operation erases one of the 32 blocks in typically 0.7 seconds, independent of the other blocks, which is about 55% improvement over the LH28F008SA.

The LH28F016SU incorporates two Page Buffers of 256 Bytes (128 Words) each to allow page data writes. This feature can improve a system write performance over previous flash memory devices.

All operations are started by a sequence of Write commands to the device. Three Status Registers (described in detail later) and a  $\overline{RY}/\overline{BY}$  output pin provide information on the progress of the requested operation.

While the LH28F008SA requires an operation to complete before the next operation can be requested, the LH28F016SU allows queuing of the next operation while the memory executes the current operation. This eliminates system overhead when writing several bytes in a row to the array or erasing several blocks at the same time. The LH28F016SUR-10 can also perform write operations to one block of memory while performing erase of another block.

The LH28F016SU provides user-selectable block locking to protect code or data such as Device Drivers, PCMCIA card information, ROM-Executable O/S or Application Code. Each block has an associated non-volatile lock-bit which determines the lock status of the block. In addition, the LH28F016SU has a master Write Protect pin ( $\overline{WP}$ ) which prevents any modifications to memory blocks whose lock-bits are set.

The LH28F016SU contains three types of Status Registers to accomplish various functions:

- A Compatible Status Register (CSR) which is 100% compatible with the LH28F008SA Flash memory's Status Register. This register, when used alone, provides a straightforward upgrade capability to the LH28F016SU from a LH28F008SA based design.
- A Global Status Register (GSR) which informs the system of command Queue status, Page Buffer status, and overall Write State Machine (WSM) status.
- 32 Block Status Registers (BSRs) which provide block-specific status information such as the block lock-bit status.

The GSR and BSR memory maps for Byte-Wide and Word-Wide modes are shown in Figures 5 and 6.

The LH28F016SU incorporates an open drain  $\overline{RY}/\overline{BY}$  output pin. This feature allows the user to OR-tie many  $\overline{RY}/\overline{BY}$  pins together in a multiple memory configuration such as a Resident Flash Array.

The LH28F016SU also incorporates a dual chip-enable function with two input pins,  $\overline{CE}_0$  and  $\overline{CE}_1$ . These pins have exactly the same functionality as the regular chip-enable pin  $\overline{CE}$  on the LH28F008SA. For minimum chip designs,  $\overline{CE}_1$  may be tied to ground and use  $\overline{CE}_0$  as the chip enable input. The LH28F016SU uses the logical combination of these two signals to enable or disable the entire chip. Both  $\overline{CE}_0$  and  $\overline{CE}_1$  must be active low to enable the device and if either one becomes inactive, the chip will be disabled. This feature, along with the open drain  $\overline{RY}/\overline{BY}$  pin, allows the system designer to reduce the number of control pins used in a large array of 16M devices.

The  $\overline{BYTE}$  pin allows either x8 or x16 read/writes to the LH28F016SU.  $\overline{BYTE}$  at logic low selects 8-bit mode with address  $A_0$  selecting between low byte and high byte. On the other hand,  $\overline{BYTE}$  at logic high enables 16-bit operation with address  $A_1$  becoming the lowest order address and address  $A_0$  is not used (don't care). A block diagram is shown in Figure 3.

The LH28F016SU is specified for a maximum access time of each version, as follows:

OPERATING TEMPERATURE	V <sub>CC</sub> SUPPLY	MAX. ACCESS (T <sub>ACC</sub> )
0 - 70°C	4.75 - 5.25 V	70 ns
0 - 70°C	4.5 - 5.5 V	80 ns
0 - 70°C	3.0 - 3.6 V	120 ns
0 - 70°C	2.7 - 3.6 V	160 ns

The LH28F016SU incorporates an Automatic Power Saving (APS) feature which substantially reduces the active current when the device is in static mode of operation (addresses not switching).

In APS mode, the typical I<sub>CC</sub> current is 2 mA at 5.0V (1 mA at 3.3 V).

A Deep Power-Down mode of operation is invoked when the  $\overline{RP}$  (called  $\overline{PWD}$  on the LH28F008SA) pin transitions low, any current operation is aborted and the device is put into the deep power-down mode. This mode brings the device power consumption to less than 5  $\mu$ A typically, and provides additional write protection by acting as a device reset pin during power transitions. When the power is turned on,  $\overline{RP}$  pin turned to low order to return the device to default configuration. When the  $\overline{3/5}$  pin is switched, or when the power transition is occurred, or at the power on/off,  $\overline{RP}$  is required to stay low in order to protect data from noise. A recovery time of 550 ns ( $V_{CC} = 5.0 \text{ V} \pm 0.5 \text{ V}$ ) is required from  $\overline{RP}$  switching high until outputs are again valid. In the Deep Power-Down state, the WSM is reset (any current operation will abort) and the CSR, GSR and BSR registers are cleared.

A CMOS Standby mode of operation is enabled when either  $\overline{CE}_0$  or  $\overline{CE}_1$  transitions high and  $\overline{RP}$  stays high with all input control pins at CMOS levels. In this mode, the device typically draws an I<sub>CC</sub> standby current of 10  $\mu$ A.

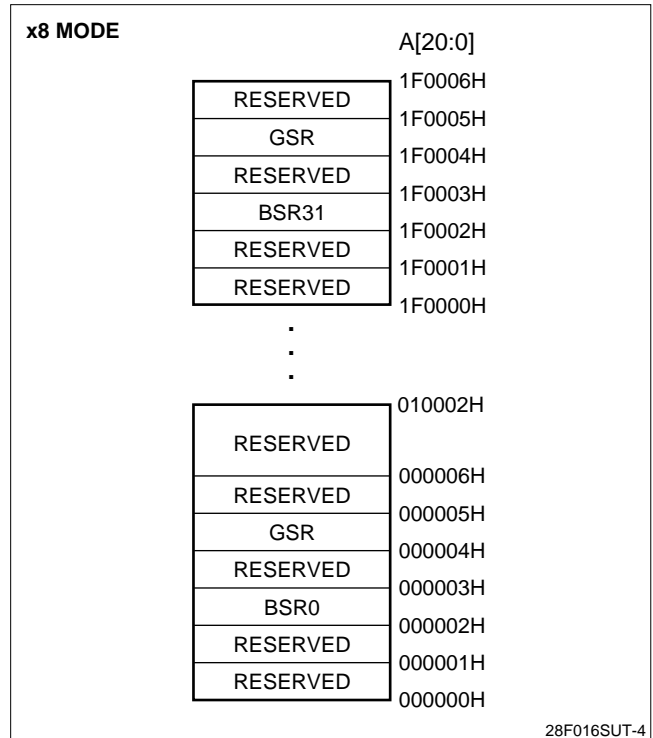
**MEMORY MAP**

1FFFFFFH		
1F0000H	64KB BLOCK	31
1EFFFFH		
1E0000H	64KB BLOCK	30
1DFFFFH		
1D0000H	64KB BLOCK	29
1CFFFFH		
1C0000H	64KB BLOCK	28
1BFFFFH		
1B0000H	64KB BLOCK	27
1AFFFFH		
1A0000H	64KB BLOCK	26
19FFFFH		
190000H	64KB BLOCK	25
18FFFFH		
180000H	64KB BLOCK	24
17FFFFH		
170000H	64KB BLOCK	23
16FFFFH		
160000H	64KB BLOCK	22
15FFFFH		
150000H	64KB BLOCK	21
14FFFFH		
140000H	64KB BLOCK	20
13FFFFH		
130000H	64KB BLOCK	19
12FFFFH		
120000H	64KB BLOCK	18
11FFFFH		
110000H	64KB BLOCK	17
10FFFFH		
100000H	64KB BLOCK	16
0FFFFFH		
0F0000H	64KB BLOCK	15
0EFFFFH		
0E0000H	64KB BLOCK	14
0DFFFFH		
0D0000H	64KB BLOCK	13
0CFFFFH		
0C0000H	64KB BLOCK	12
0BFFFFH		
0B0000H	64KB BLOCK	11
0AFFFFH		
0A0000H	64KB BLOCK	10
09FFFFH		
090000H	64KB BLOCK	9
08FFFFH		
080000H	64KB BLOCK	8
07FFFFH		
070000H	64KB BLOCK	7
06FFFFH		
060000H	64KB BLOCK	6
05FFFFH		
050000H	64KB BLOCK	5
04FFFFH		
040000H	64KB BLOCK	4
03FFFFH		
030000H	64KB BLOCK	3
02FFFFH		
020000H	64KB BLOCK	2
01FFFFH		
010000H	64KB BLOCK	1
00FFFFH		
000000H	64KB BLOCK	0

28F016SUT-3

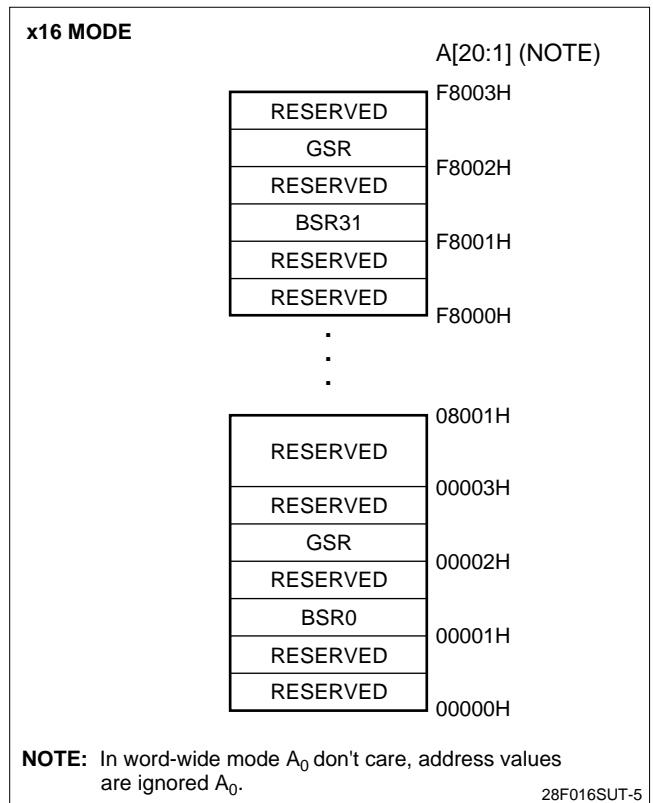
**Figure 4. LH28F016SU Memory Map (Byte-Wide Mode)**

**Extended Status Registers Memory Map**



28F016SUT-4

**Figure 5. Extended Status Register Memory Map (Byte-Wide Mode)**



28F016SUT-5

**Figure 6. Extended Status Register Memory Map (Word-Wide Mode)**

## BUS OPERATIONS, COMMANDS AND STATUS REGISTER DEFINITIONS

### Bus Operations for Word-Wide Mode ( $\overline{\text{BYTE}} = V_{\text{IH}}$ )

MODE	$\overline{\text{RP}}$	$\overline{\text{CE}}_1$	$\overline{\text{CE}}_0$	$\overline{\text{OE}}$	$\overline{\text{WE}}$	$\text{A}_1$	$\text{DQ}_0 - \text{DQ}_{15}$	$\overline{\text{RY}}/\overline{\text{BY}}$	NOTE
Read	$V_{\text{IH}}$	$V_{\text{IL}}$	$V_{\text{IL}}$	$V_{\text{IL}}$	$V_{\text{IH}}$	X	$\text{D}_{\text{OUT}}$	X	1, 2, 7
Output Disable	$V_{\text{IH}}$	$V_{\text{IL}}$	$V_{\text{IL}}$	$V_{\text{IH}}$	$V_{\text{IH}}$	X	High-Z	X	1, 6, 7
Standby	$V_{\text{IH}}$	$V_{\text{IL}}$ $V_{\text{IH}}$ $V_{\text{IH}}$	$V_{\text{IH}}$ $V_{\text{IL}}$ $V_{\text{IH}}$	X	X	X	High-Z	X	1, 6, 7
Deep Power-Down	$V_{\text{IL}}$	X	X	X	X	X	High-Z	$V_{\text{OH}}$	1, 3
Manufacturer ID	$V_{\text{IH}}$	$V_{\text{IL}}$	$V_{\text{IL}}$	$V_{\text{IL}}$	$V_{\text{IH}}$	$V_{\text{IL}}$	00B0H	$V_{\text{OH}}$	4
Device ID	$V_{\text{IH}}$	$V_{\text{IL}}$	$V_{\text{IL}}$	$V_{\text{IL}}$	$V_{\text{IH}}$	$V_{\text{IH}}$	6688H	$V_{\text{OH}}$	4
Write	$V_{\text{IH}}$	$V_{\text{IL}}$	$V_{\text{IL}}$	$V_{\text{IH}}$	$V_{\text{IL}}$	X	$\text{D}_{\text{IN}}$	X	1, 5, 6

### Bus Operations For Byte-Wide Mode ( $\overline{\text{BYTE}} = V_{\text{IL}}$ )

MODE	$\overline{\text{RP}}$	$\overline{\text{CE}}_1$	$\overline{\text{CE}}_0$	$\overline{\text{OE}}$	$\overline{\text{WE}}$	$\text{A}_0$	$\text{DQ}_0 - \text{DQ}_7$	$\overline{\text{RY}}/\overline{\text{BY}}$	NOTE
Read	$V_{\text{IH}}$	$V_{\text{IL}}$	$V_{\text{IL}}$	$V_{\text{IL}}$	$V_{\text{IH}}$	X	$\text{D}_{\text{OUT}}$	X	1, 2, 7
Output Disable	$V_{\text{IH}}$	$V_{\text{IL}}$	$V_{\text{IL}}$	$V_{\text{IH}}$	$V_{\text{IH}}$	X	High-Z	X	1, 6, 7
Standby	$V_{\text{IH}}$	$V_{\text{IL}}$ $V_{\text{IH}}$ $V_{\text{IH}}$	$V_{\text{IH}}$ $V_{\text{IL}}$ $V_{\text{IH}}$	X	X	X	High-Z	X	1, 6, 7
Deep Power-Down	$V_{\text{IL}}$	X	X	X	X	X	High-Z	$V_{\text{OH}}$	1, 3
Manufacturer ID	$V_{\text{IH}}$	$V_{\text{IL}}$	$V_{\text{IL}}$	$V_{\text{IL}}$	$V_{\text{IH}}$	$V_{\text{IL}}$	B0H	$V_{\text{OH}}$	4
Device ID	$V_{\text{IH}}$	$V_{\text{IL}}$	$V_{\text{IL}}$	$V_{\text{IL}}$	$V_{\text{IH}}$	$V_{\text{IH}}$	88H	$V_{\text{OH}}$	4
Write	$V_{\text{IH}}$	$V_{\text{IL}}$	$V_{\text{IL}}$	$V_{\text{IH}}$	$V_{\text{IL}}$	X	$\text{D}_{\text{IN}}$	X	1, 5, 6

#### NOTES:

- X can be  $V_{\text{IH}}$  or  $V_{\text{IL}}$  for address or control pins except for  $\overline{\text{RY}}/\overline{\text{BY}}$ , which is either  $V_{\text{OL}}$  or  $V_{\text{OH}}$ .
- $\overline{\text{RY}}/\overline{\text{BY}}$  output is open drain. When the WSM is ready, Erase is suspended or the device is in deep power-down mode,  $\overline{\text{RY}}/\overline{\text{BY}}$  will be at  $V_{\text{OH}}$  if it is tied to  $V_{\text{CC}}$  through a resistor. When the  $\overline{\text{RY}}/\overline{\text{BY}}$  at  $V_{\text{OH}}$  is independent of  $\overline{\text{OE}}$  while a WSM operation is in progress.
- $\overline{\text{RP}}$  at  $\text{GND} \pm 0.2 \text{ V}$  ensures the lowest deep power-down current.
- $\text{A}_0$  and  $\text{A}_1$  at  $V_{\text{IL}}$  provide manufacturer ID codes in x8 and x16 modes respectively.  $\text{A}_0$  and  $\text{A}_1$ , at  $V_{\text{IH}}$  provide device ID codes in x8 and x16 modes respectively. All other addresses are set to zero.
- Commands for different Erase operations, Data Write operations of Lock-Block operations can only be successfully completed when  $V_{\text{PP}} = V_{\text{PPH}}$ .
- While the WSM is running,  $\overline{\text{RY}}/\overline{\text{BY}}$  in Level-Mode (default) stays at  $V_{\text{OL}}$  until all operations are complete.  $\overline{\text{RY}}/\overline{\text{BY}}$  goes to  $V_{\text{OH}}$  when the WSM is not busy or in erase suspend mode.
- $\overline{\text{RY}}/\overline{\text{BY}}$  may be at  $V_{\text{OL}}$  while the WSM is busy performing various operations. For example, a status register read during a write operations.



## LH28F008SA-Compatible Mode Command Bus Definitions

COMMAND	FIRST BUS CYCLE			SECOND BUS CYCLE			NOTE
	OPER.	ADDRESS	DATA	OPER.	ADDRESS	DATA	
Read Array	Write	X	FFH	Read	AA	AD	
Intelligent Identifier	Write	X	90H	Read	IA	ID	1
Read Compatible Status Register	Write	X	70H	Read	X	CSRD	2
Clear Status Register	Write	X	50H				3
Word Write	Write	X	40H	Write	WA	WD	
Alternate Word/Byte Write	Write	X	10H	Write	WA	WD	
Block Erase/Confirm	Write	X	20H	Write	BA	D0H	
Erase Suspend/Resume	Write	X	B0H	Write	X	D0H	

**ADDRESS**

AA = Array Address  
 BA = Block Address  
 IA = Identifier Address  
 WA = Write Address  
 X = Don't Care

**DATA**

AD = Array Data  
 CSRD = CSR Data  
 ID = Identifier Data  
 WD = Write Data

**NOTES:**

1. Following the intelligent identifier command, two Read operations access the manufacturer and device signature codes.
2. The CSR is automatically available after device enters Data Write, Erase or Suspend operations.
3. Clears CSR.3, CSR.4, and CSR.5. Also clears GSR.5 and all BSR.5 and BSR.2 bits. See Status register definitions.

## LH28F016SU Performance Enhancement Command Bus Definitions

COMMAND	MODE	FIRST BUS CYCLE			SECOND BUS CYCLE			THIRD BUS CYCLE			NOTE
		OPER.	ADDR.	DATA	OPER.	ADDR.	DATA	OPER.	ADDR.	DATA	
Read Extended Status Register		Write	X	71H	Read	RA	GSRD BSRD				1
Page Buffer Swap		Write	X	72H							7
Read Page Buffer		Write	X	75H	Read	PA	PD				
Single Load to Page Buffer		Write	X	74H	Write	PA	PD				
Sequential Load to Page Buffer	x8	Write	X	E0H	Write	X	BCL	Write	X	BCH	4, 6, 10
	x16	Write	X	E0H	Write	X	WCL	Write	X	WCH	4, 5, 6, 10
Page Buffer Write to Flash	x8	Write	X	0CH	Write	A0	BC (L, H)	Write	WA	BC (H, L)	3, 4, 9, 10
	x16	Write	X	0CH	Write	X	WCL	Write	WA	WCH	4, 5, 10
Two-Byte Write	x8	Write	X	FBH	Write	A0	WD (L, H)	Write	WA	WD (H, L)	3
Block Erase/Confirm		Write	X	20H	Write	BA	D0H				
Lock Block/Confirm		Write	X	77H	Write	BA	D0H				
Upload Status Bits/Confirm		Write	X	97H	Write	X	D0H				2
Upload Device Information		Write	X	99H	Write	X	D0H				
Erase All Unlocked Blocks/Confirm		Write	X	A7H	Write	X	D0H				
$\overline{RY}/\overline{BY}$ Enable to Level-Mode		Write	X	96H	Write	X	01H				8
$\overline{RY}/\overline{BY}$ Pulse-On-Write		Write	X	96H	Write	X	02H				8
$\overline{RY}/\overline{BY}$ Pulse-On-Erase		Write	X	96H	Write	X	03H				8
$\overline{RY}/\overline{BY}$ Disable		Write	X	96H	Write	X	04H				8
Sleep		Write	X	F0H							
Abort		Write	X	80H							

**ADDRESS**

BA = Block Address  
 PA = Page Buffer Address  
 RA = Extended Register Address  
 WA = Write Address  
 X = Don't Care

**DATA**

AD = Array Data  
 PD = Page Buffer Data  
 BSRD = BSR Data  
 GSRD = GSR Data  
 WC (L, H) = Word Count (Low, High)  
 BC (L, H) = Byte Count (Low, High)  
 WD (L, H) = Write Data (Low, High)

**NOTES:**

1. RA can be the GSR address or any BSR address. See Figure 5 and 6 for Extended Status Register Memory Maps.
2. Upon device power-up, all BSR lock-bits come up locked. The Uploaded Status Bits command must be written to reflect the actual lock-bit status.
3.  $A_0$  is automatically complemented to load second byte of data.  $\overline{\text{BYTE}}$  must be at  $V_{IL}$ .  $A_0$  value determines which WD/BC is supplied first:  $A_0 = 0$  looks at the WDL/BCL,  $A_0 = 1$  looks at the WDH/BCH.
4. BCH/WCH must be at 00H for this product because of the 256-Byte (128 Word) Page Buffer size and to avoid writing the Page Buffer contents into more than one 256-Byte segment within an array block. They are simply shown for future Page Buffer expandability.
5. In x16 mode, only the lower byte  $DQ_0 - DQ_7$  is used for WCL and WCH. The upper byte  $DQ_8 - DQ_{15}$  is a don't care.
6. PA and PD (Whose count is given in cycles 2 and 3) are supplied starting in the 4th cycle which is not shown.
7. This command allows the user to swap between available Page Buffers (0 or 1).
8. These commands reconfigure  $\overline{\text{RY}}/\overline{\text{BY}}$  output to one of two pulse-modes or enable and disable the  $\overline{\text{RY}}/\overline{\text{BY}}$  function.
9. Write address, WA, is the Destination address in the flash array which must match the Source address in the Page Buffer. Refer to the LH28F016SU User's Manual.
10. BCL = 00H corresponds to a Byte count of 1. Similarly, WCL = 00H corresponds to a Word count of 1.

**Compatible Status Register**

WSMS	ESS	ES	DWS	VPPS	R	R	R
7	6	5	4	3	2	1	0

CSR.7 = WRITE STATE MACHINE STATUS (WSMS)  
 1 = Ready  
 0 = Busy

CSR.6 = ERASE-SUSPEND STATUS (ESS)  
 1 = Erase Suspended  
 0 = Erase in Progress/Completed

CSR.5 = ERASE STATUS (ES)  
 1 = Error in Block Erasure  
 0 = Successful Block Erase

CSR.4 = DATA-WRITE STATUS (DWS)  
 1 = Error in Data Write  
 0 = Data Write Successful

CSR.3 =  $V_{PP}$  STATUS (VPPS)  
 1 =  $V_{PP}$  Low Detect, Operation Abort  
 0 =  $V_{PP}$  OK

**NOTES:**

1.  $\overline{\text{RY}}/\overline{\text{BY}}$  output or WSMS bit must be checked to determine completion of an operation (Erase Suspend, Erase or Data Write) before the appropriate Status bit (ESS, ES or DWS) is checked for success.
2. If DWS and ES are set to '1' during an erase attempt, an improper command sequence was entered. Clear the CSR and attempt the operation again.
3. The VPPS bit, unlike an A/D converter, does not provide continuous indication of  $V_{PP}$  level. The WSM interrogates  $V_{PP}$ 's level only after the Data-Write or Erase command sequences have been entered, and informs the system if  $V_{PP}$  has not been switched on. VPPS is not guaranteed to report accurate feedback between  $V_{PPL}$  and  $V_{PPH}$ .
4. CSR.2 - CSR.0 = Reserved for future enhancements. These bits are reserved for future use and should be masked out when polling the CSR.

## GLOBAL STATUS REGISTER

WSMS	OSS	DOS	DSS	QS	PBAS	PBS	PBSS
7	6	5	4	3	2	1	0

GSR.7 = WRITE STATE MACHINE STATUS (WSMS)

- 1 = Ready
- 0 = Busy

GSR.6 = OPERATION SUSPEND STATUS (OSS)

- 1 = Operation Suspended
- 0 = Operation in Progress/Completed

GSR.5 = DEVICE OPERATION STATUS (DOS)

- 1 = Operation Unsuccessful
- 0 = Operation Successful or Currently Running

GSR.4 = DEVICE SLEEP STATUS(DSS)

- 1 = Device in Sleep
- 0 = Device Not in Sleep

MATRIX 5/4

- 00 = Operation Successful or currently Running
- 01 = Device in Sleep Mode or Pending Sleep
- 10 = Operation Unsuccessful
- 11 = Operation Unsuccessful or Aborted

GSR.3 = QUEUE STATUS (QS)

- 1 = Queue Full
- 0 = Queue Available

GSR.2 = PAGE BUFFER AVAILABLE STATUS (PBAS)

- 1 = One or Two Page Buffers Available
- 0 = No Page Buffer Available

GSR.1 = PAGE BUFFER STATUS (PBS)

- 1 = Selected Page Buffer Ready
- 0 = Selected Page Buffer Busy

GSR.0 = PAGE BUFFER SELECT STATUS (PBSS)

- 1 = Page Buffer 1 Selected
- 0 = Page buffer 0 Selected

**NOTES:**

1.  $\overline{RY}/\overline{BY}$  output or WSMS bit must be checked to determine completion of an operation (Block Lock, Suspend, any  $\overline{RY}/\overline{BY}$  reconfiguration, Upload Status Bits, Erase or Data Write) before the appropriate Status bit (OSS or DOS) is checked for success.
2. If operation currently running, then GSR.7 = 0.
3. If device pending sleep, then GSR.7 = 0.
4. Operation aborted: Unsuccessful due to Abort command.
5. The device contains two Page Buffers.
6. Selected Page Buffer is currently busy with WSM operation.
7. When multiple operations are queued, checking BSR.7 only provides indication of completion for that particular block. GSR.7 provides indication when all queued operations are completed.

**BLOCK STATUS REGISTER**

BS	BLS	BOS	BOAS	QS	VPPS	R	R
7	6	5	4	3	2	1	0

BSR.7 = BLOCK STATUS (BS)  
1 = Ready  
0 = Busy

BSR.6 = BLOCK-LOCK STATUS (BLS)  
1 = Block Unlocked for Write/Erase  
0 = Block Locked for Write/Erase

BSR.5 = BLOCK OPERATION STATUS (BOS)  
1 = Operation Unsuccessful  
0 = Operation Successful or Currently Running

BSR.4 = BLOCK OPERATION ABORT STATUS (BOAS)  
1 = Operation Aborted  
0 = Operation Not Aborted

MATRIX 5/4  
00 = Operation Successful or Currently Running  
01 = Not a valid Combination  
10 = Operation Unsuccessful  
11 = Operation Aborted

BSR.3 = QUEUE STATUS (QS)  
1 = Queue Full  
0 = Queue Available

BSR.2 = V<sub>PP</sub> STATUS (V<sub>PPS</sub>)  
1 = V<sub>PP</sub> Low Detect, Operation Abort  
0 = V<sub>PP</sub> OK

**NOTES:**

1.  $\overline{RY}/\overline{BY}$  output or BS bit must be checked to determine completion of an operation (Block Lock, Suspend, Erase or Data Write) before the appropriate Status bits (BOS, BLS) is checked for success.
2. The BOAS bit will not be set until BSR.7 = 1.
3. Operation halted via Abort command.
4. BSR.1-0 = Reserved for future enhancements. These bits are reserved for future use; mask them out when polling the BSRs.
5. When multiple operations are queued, checking BSR.7 only provides indication of completion for that particular block. GSR.7 provides indication when all queued operations are completed.

**ELECTRICAL SPECIFICATIONS****Absolute Maximum Ratings\***

Temperature under bias ..... 0°C to +80°C

Storage temperature ..... -65°C to +125°C

*\*WARNING: Stressing the device beyond the “Absolute Maximum Ratings” may cause permanent damage. These are stress ratings only. Operation beyond the “Operating Conditions” is not recommended and extended exposure beyond the “Operating Conditions” may affect device reliability.*

**V<sub>CC</sub> = 3.3 V ± 0.3 V Systems<sup>4</sup>**

SYMBOL	PARAMETER	MIN.	MAX.	UNITS	TEST CONDITIONS	NOTE
T <sub>A</sub>	Operating Temperature, Commercial	0	70	°C	Ambient Temperature	1
V <sub>CC</sub>	V <sub>CC</sub> with Respect to GND	-0.2	7.0	V		2
V <sub>PP</sub>	V <sub>PP</sub> Supply Voltage with Respect to GND	-0.2	7.0	V		2
V	Voltage on any Pin (Except V <sub>CC</sub> , V <sub>PP</sub> ) with Respect to GND	-0.5	V <sub>CC</sub> + 0.5	V		2
I	Current into any Non-Supply Pin		±30	mA		
I <sub>OUT</sub>	Output Short Circuit Current		100.0	mA		3

**V<sub>CC</sub> = 5.0 V ± 0.5 V Systems<sup>4</sup>**

SYMBOL	PARAMETER	MIN.	MAX.	UNITS	TEST CONDITIONS	NOTE
T <sub>A</sub>	Operating Temperature, Commercial	0	70	°C	Ambient Temperature	1
V <sub>CC</sub>	V <sub>CC</sub> with Respect to GND	-0.2	7.0	V		2
V <sub>PP</sub>	V <sub>PP</sub> Supply Voltage with Respect to GND	-0.2	7.0	V		2
V	Voltage on any Pin (Except V <sub>CC</sub> , V <sub>PP</sub> ) with Respect to GND	-0.5	7.0	V		2
I	Current into any Non-Supply Pin		±30	mA		
I <sub>OUT</sub>	Output Short Circuit Current		100.0	mA		3

**NOTES:**

1. Operating temperature is for commercial product defined by this specification.
2. Minimum DC voltage is -0.5 V on input/output pins. During transitions, this level may undershoot to -2.0 V for periods < 20 ns. Maximum DC voltage on input/output pins is V<sub>CC</sub> + 0.5 V which, during transitions, may overshoot to V<sub>CC</sub> + 2.0 V for periods < 20 ns.
3. Output shorted for no more than one second. No more than one output shorted at a time.
4. AC specifications are valid at both voltage ranges. See DC Characteristics tables for voltage range-specific specifications.

## Capacitance

### For 3.3 V Systems

SYMBOL	PARAMETER	TYP.	MAX.	UNITS	TEST CONDITIONS	NOTE
$C_{IN}$	Capacitance Looking into an Address/Control Pin	6	8	pF	$T_A = 25^\circ\text{C}$ , $f = 1.0\text{ MHz}$	1
$C_{OUT}$	Capacitance Looking into an Output Pin	8	12	pF	$T_A = 25^\circ\text{C}$ , $f = 1.0\text{ MHz}$	1
$C_{LOAD}$	Load Capacitance Driven by Outputs for Timing Specifications		50	pF	For $V_{CC} = 3.3\text{ V} \pm 0.3\text{ V}$	1
	Equivalent Testing Load Circuit		2.5	ns	50 $\Omega$ transmission line delay	

## Capacitance

### For 5.0 V Systems

SYMBOL	PARAMETER	TYP.	MAX.	UNITS	TEST CONDITIONS	NOTE
$C_{IN}$	Capacitance Looking into an Address/Control Pin	6	8	pF	$T_A = 25^\circ\text{C}$ , $f = 1.0\text{ MHz}$	1
$C_{OUT}$	Capacitance Looking into an Output Pin	8	12	pF	$T_A = 25^\circ\text{C}$ , $f = 1.0\text{ MHz}$	1
$C_{LOAD}$	Load Capacitance Driven by Outputs for Timing Specifications		100	pF	For $V_{CC} = 5.0\text{ V} \pm 0.5\text{ V}$	1
	Equivalent Testing Load Circuit $V_{CC} \pm 10\%$		2.5	ns	25 $\Omega$ transmission line delay	
	Equivalent Testing Load Circuit $V_{CC} \pm 5\%$		2.5	ns	83 $\Omega$ transmission line delay	

#### NOTE:

1. Sampled, not 100% tested.

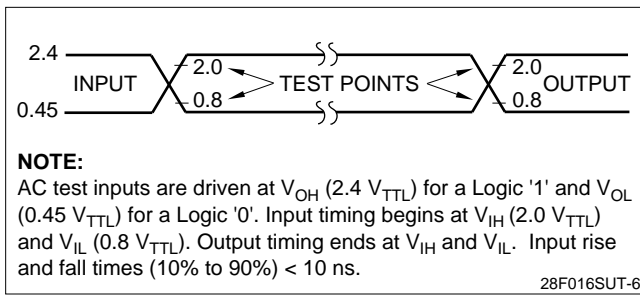
## Timing Nomenclature

All 3.3 V system timings are measured from where signals cross 1.5 V. For 5.0 V systems use the standard JEDEC crosspoint definitions. Each timing parameter consists of 5 characters. Some common examples are defined below:

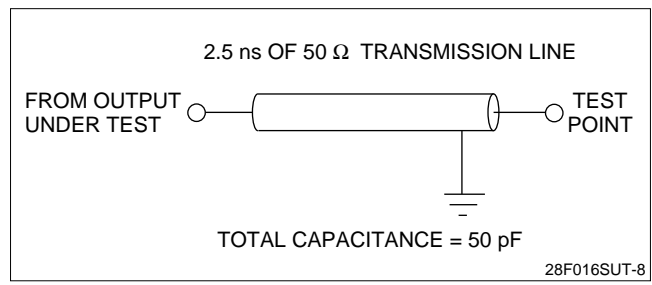
$t_{CE}$   $t_{ELQV}$  time (t) from  $\overline{CE}$  (E) going low (L) to the outputs (Q) becoming valid (V)  
 $t_{OE}$   $t_{GLQV}$  time (t) from  $\overline{OE}$  (G) going low (L) to the outputs (Q) becoming valid (V)  
 $t_{ACC}$   $t_{AVQV}$  time (t) from address (A) valid (V) to the outputs (Q) becoming valid (V)  
 $t_{AS}$   $t_{AVWH}$  time (t) from address (A) valid (V) to  $\overline{WE}$  (W) going high (H)  
 $t_{DH}$   $t_{WHDx}$  time (t) from  $\overline{WE}$  (W) going high (H) to when the data (D) can become undefined (X)

	PIN CHARACTERS		PIN STATES
A	Address Inputs	H	High
D	Data Inputs	L	Low
Q	Data Outputs	V	Valid
E	$\overline{CE}$ (Chip Enable)	X	Driven, but not necessarily valid
G	$\overline{OE}$ (Output Enable)	Z	High Impedance
W	$\overline{WE}$ (Write Enable)		
P	$\overline{RP}$ (Deep Power-Down Pin)		
R	$\overline{RY}/\overline{BY}$ (Ready/Busy)		
V	Any Voltage Level		
Y	$\overline{3/5}$ Pin		
5 V	$V_{CC}$ at 4.5 V Min.		
3 V	$V_{CC}$ at 3.0 V Min.		

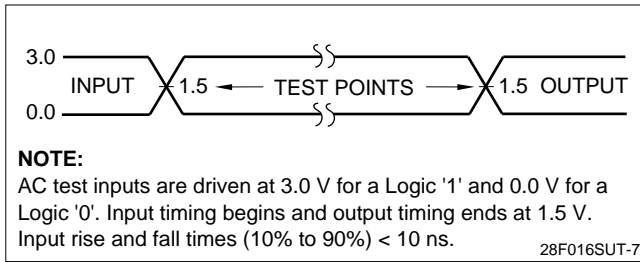




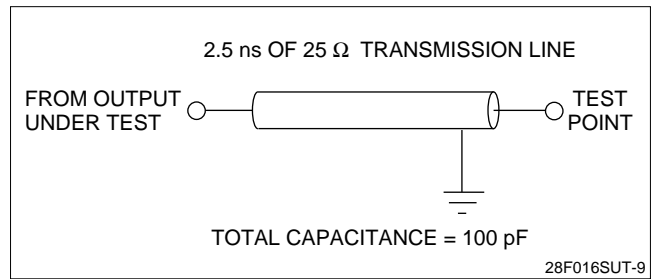
**Figure 7. Transient Input/Output Reference Waveform ( $V_{CC} = 5.0 V$ )**



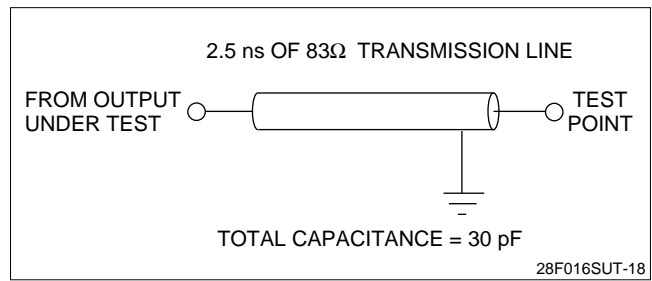
**Figure 9. Transient Equivalent Testing Load Circuit ( $V_{CC} = 3.3 V$ )**



**Figure 8. Equivalent Testing Load Circuit ( $V_{CC} = 3.3 V$ )**



**Figure 10. Transient Equivalent Testing Load Circuit ( $V_{CC} = 5.0 V$ )**



**Figure 11. High Speed Transient Equivalent Testing Load Circuit ( $V_{CC} = 5.0 V \pm 5\%$ )**

## DC Characteristics

$$V_{CC} = 3.3 \text{ V} \pm 0.3 \text{ V}, T_A = 0^\circ\text{C to } +70^\circ\text{C}$$

$$\overline{3/5} = \text{Pin Set High for 3.3 V Operations}$$

SYMBOL	PARAMETER	TYP.	MIN.	MAX.	UNITS	TEST CONDITIONS	NOTE
$I_{IL}$	Input Load Current			±1	μA	$V_{CC} = V_{CC} \text{ MAX.}, V_{IN} = V_{CC} \text{ or GND}$	1
$I_{LO}$	Output Leakage Current			±10	μA	$V_{CC} = V_{CC} \text{ MAX.}, V_{IN} = V_{CC} \text{ or GND}$	1
$I_{CCS}$	$V_{CC}$ Standby Current	4		8	μA	$V_{CC} = V_{CC} \text{ MAX.},$ $\overline{CE}_0, \overline{CE}_1, \overline{RP} = V_{CC} \pm 0.2 \text{ V}$ $\overline{BYTE}, \overline{WP}, \overline{3/5} = V_{CC} \pm 0.2 \text{ V or GND}$ $\pm 0.2 \text{ V}$	1, 4
		1		4	mA	$V_{CC} = V_{CC} \text{ MAX.},$ $\overline{CE}_0, \overline{CE}_1, \overline{RP} = V_{IH}$ $\overline{BYTE}, \overline{WP}, \overline{3/5} = V_{IH} \text{ or } V_{IL}$	
$I_{CCD}$	$V_{CC}$ Deep Power-Down Current	1		5	μA	$\overline{RP} = \text{GND} \pm 0.2 \text{ V}$	1
$I_{CCR}^1$	$V_{CC}$ Read Current	30		35	mA	$V_{CC} = V_{CC} \text{ MAX.},$ CMOS: $\overline{CE}_0, \overline{CE}_1 = \text{GND} \pm 0.2 \text{ V}$ $\overline{BYTE} = \text{GND} \pm 0.2 \text{ V or } V_{CC} \pm 0.2 \text{ V}$ Inputs = $\text{GND} \pm 0.2 \text{ V or } V_{CC} \pm 0.2 \text{ V}$ TTL: $\overline{CE}_0, \overline{CE}_1 = V_{IL},$ $\overline{BYTE} = V_{IH} \text{ or } V_{IL}$ Inputs = $V_{IL} \text{ or } V_{IH}$ $f = 8 \text{ MHz}, I_{OUT} = 0 \text{ mA}$	1, 3, 4
$I_{CCR}^2$	$V_{CC}$ Read Current	15		20	mA	$V_{CC} = V_{CC} \text{ MAX.},$ CMOS: $\overline{CE}_0, \overline{CE}_1 = \text{GND} \pm 0.2 \text{ V}$ $\overline{BYTE} = V_{CC} \pm 0.2 \text{ V or GND} \pm 0.2 \text{ V}$ Inputs = $\text{GND} \pm 0.2 \text{ V or } V_{CC} \pm 0.2 \text{ V}$ TTL: $\overline{CE}_0, \overline{CE}_1 = V_{IL},$ $\overline{BYTE} = V_{IH} \text{ or } V_{IL}$ Inputs = $V_{IL} \text{ or } V_{IH}$ $f = 4 \text{ MHz}, I_{OUT} = 0 \text{ mA}$	1, 3, 4
$I_{CCW}$	$V_{CC}$ Write Current	8		12	mA	Word/Byte Write in Progress	1
$I_{CCE}$	$V_{CC}$ Block Erase Current	6		12	mA	Block Erase in Progress	1
$I_{CCES}$	$V_{CC}$ Erase Suspend Current	3		6	mA	$\overline{CE}_0, \overline{CE}_1 = V_{IH}$ Block Erase Suspended	1, 2
$I_{PPS}$	$V_{PP}$ Standby Current	±1		±10	μA	$V_{PP} \leq V_{CC}$	1
$I_{PPD}$	$V_{PP}$ Deep Power-Down Current	0.2		5	μA	$\overline{RP} = \text{GND} \pm 0.2 \text{ V}$	

**DC Characteristics (Continued)**

$$V_{CC} = 3.3 \text{ V} \pm 0.3 \text{ V}, T_A = 0^\circ\text{C to } +70^\circ\text{C}$$

$$\overline{3/5} = \text{Pin Set High for 3.3 V Operations}$$

SYMBOL	PARAMETER	TYPE	MIN.	MAX.	UNITS	TEST CONDITIONS	NOTE
$I_{PPR}$	$V_{PP}$ Read Current			200	$\mu\text{A}$	$V_{PP} > V_{CC}$	1
$I_{PPW}$	$V_{PP}$ Write Current	40		60	mA	$V_{PP} = V_{PPH}$ , Word/Byte Write in Progress	1
$I_{PPE}$	$V_{PP}$ Erase Current	20		40	mA	$V_{PP} = V_{PPH}$ , Block Erase in Progress	1
$I_{PPES}$	$V_{PP}$ Erase Suspend Current			200	$\mu\text{A}$	$V_{PP} = V_{PPH}$ , Block Erase Suspended	1
$V_{IL}$	Input Low Voltage		-0.3	0.8	V		
$V_{IH}$	Input High Voltage		2.0	$V_{CC} + 0.3$	V		
$V_{OL}$	Output Low Voltage			0.4	V	$V_{CC} = V_{CC} \text{ MIN. and } I_{OL} = 4 \text{ mA}$	
$V_{OH}^1$	Output High Voltage		2.4		V	$I_{OH} = 2.0 \text{ mA}$ $V_{CC} = V_{CC} \text{ MIN.}$	
$V_{OH}^2$			$V_{CC} - 0.2$		V	$I_{OH} = 100 \mu\text{A}$ $V_{CC} = V_{CC} \text{ MIN.}$	
$V_{PPL}$	$V_{PP}$ during Normal Operations		0.0	5.5	V		
$V_{PPH}$	$V_{PP}$ during Write/Erase Operations	5.0	4.5	5.5	V		
$V_{LKO}$	$V_{CC}$ Erase/Write Lock Voltage		2.0		V		

**NOTES:**

- All currents are in RMS unless otherwise noted. Typical values at  $V_{CC} = 3.3 \text{ V}$ ,  $V_{PP} = 5.0 \text{ V}$ ,  $T = 25^\circ\text{C}$ . These currents are valid for all product versions (package and speeds).
- $I_{CCES}$  is specified with the device de-selected. If the device is read while in erase suspend mode, current draw is the sum of  $I_{CCES}$  and  $I_{CCR}$ .
- Automatic Power Saving (APS) reduces  $I_{CCR}$  to less than 1 mA in Static operation.
- CMOS inputs are either  $V_{CC} \pm 0.2 \text{ V}$  or  $\text{GND} \pm 0.2 \text{ V}$ . TTL Inputs are either  $V_{IL}$  or  $V_{IH}$ .

## DC Characteristics

 $V_{CC} = 5.0\text{ V} \pm 0.5\text{ V}, T_A = 0^\circ\text{C to } +70^\circ\text{C}$ 
 $\overline{3.5}$  Pin Set Low for 5 V Operations

SYMBOL	PARAMETER	TYP.	MIN.	MAX.	UNITS	TEST CONDITIONS	NOTE
$I_{IL}$	Input Load Current			$\pm 1$	$\mu\text{A}$	$V_{CC} = V_{CC\text{ MAX.}}, V_{IN} = V_{CC}$ or GND	1
$I_{LO}$	Output Leakage Current			$\pm 10$	$\mu\text{A}$	$V_{CC} = V_{CC\text{ MAX.}}, V_{IN} = V_{CC}$ or GND	1
$I_{CCS}$	$V_{CC}$ Standby Current	5		10	$\mu\text{A}$	$V_{CC} = V_{CC\text{ MAX.}},$ $\overline{CE}_0, \overline{CE}_1, \overline{RP} = V_{CC} \pm 0.2\text{ V}$ $\overline{BYTE}, \overline{WP}, \overline{3/5} = V_{CC} \pm 0.2\text{ V}$ or GND $\pm 0.2\text{ V}$	1, 4
		2		4	mA	$V_{CC} = V_{CC\text{ MAX.}},$ $\overline{CE}_0, \overline{CE}_1, \overline{RP} = V_{IH}$ $\overline{BYTE}, \overline{WP}, \overline{3/5} = V_{IH}$ or $V_{IL}$	
$I_{CCD}$	$V_{CC}$ Deep Power-Down Current	1		5	$\mu\text{A}$	$\overline{RP} = \text{GND} \pm 0.2\text{ V}$	1
$I_{CCR}^1$	$V_{CC}$ Read Current	50		60	mA	$V_{CC} = V_{CC\text{ MAX.}},$ CMOS: $\overline{CE}_0, \overline{CE}_1 = \text{GND} \pm 0.2\text{ V}$ $\overline{BYTE} = \text{GND} \pm 0.2\text{ V}$ or $V_{CC} \pm 0.2\text{ V}$ Inputs = GND $\pm 0.2\text{ V}$ or $V_{CC} \pm 0.2\text{ V}$ TTL: $\overline{CE}_0, \overline{CE}_1 = V_{IL},$ $\overline{BYTE} = V_{IH}$ or $V_{IL}$ Inputs = $V_{IL}$ or $V_{IH}$ $f = 10\text{ MHz}, I_{OUT} = 0\text{ mA}$	1, 3, 4
$I_{CCR}^2$	$V_{CC}$ Read Current	30		35	mA	$V_{CC} = V_{CC\text{ MAX.}},$ CMOS: $\overline{CE}_0, \overline{CE}_1 = \text{GND} \pm 0.2\text{ V}$ $\overline{BYTE} = V_{CC} \pm 0.2\text{ V}$ or GND $\pm 0.2\text{ V}$ Inputs = GND $\pm 0.2\text{ V}$ or $V_{CC} \pm 0.2\text{ V}$ TTL: $\overline{CE}_0, \overline{CE}_1 = V_{IL},$ $\overline{BYTE} = V_{IH}$ or $V_{IL}$ Inputs = $V_{IL}$ or $V_{IH}$ $f = 5\text{ MHz}, I_{OUT} = 0\text{ mA}$	1, 3, 4
$I_{CCW}$	$V_{CC}$ Write Current	25		35	mA	Word/Byte Write in Progress	1
$I_{CCE}$	$V_{CC}$ Block Erase Current	18		25	mA	Block Erase in Progress	1
$I_{CCES}$	$V_{CC}$ Erase Suspend Current	5		10	mA	$\overline{CE}_0, \overline{CE}_1 = V_{IH}$ Block Erase Suspended	1, 2
$I_{PPS}$	$V_{PP}$ Standby Current			$\pm 10$	$\mu\text{A}$	$V_{PP} \leq V_{CC}$	1
$I_{PPD}$	$V_{PP}$ Deep Power-Down Current	0.2		5	$\mu\text{A}$	$\overline{RP} = \text{GND} \pm 0.2\text{ V}$	1

**DC Characteristics (Continued)**

$$V_{CC} = 5.0 \text{ V} \pm 0.5 \text{ V}, T_A = 0^\circ\text{C to } +70^\circ\text{C}$$

$\overline{3.5}$  Pin Set Low for 5 V Operations

SYMBOL	PARAMETER	TYPE	MIN.	MAX.	UNITS	TEST CONDITIONS	NOTE
$I_{PPR}$	$V_{PP}$ Read Current	65		200	$\mu\text{A}$	$V_{PP} > V_{CC}$	1
$I_{PPW}$	$V_{PP}$ Write Current	40		60	mA	$V_{PP} = V_{PPH}$ , Word/Byte Write in Progress	1
$I_{PPE}$	$V_{PP}$ Erase Current	20		40	mA	$V_{PP} = V_{PPH}$ , Block Erase in Progress	1
$I_{PPES}$	$V_{PP}$ Erase Suspend Current	65		200	$\mu\text{A}$	$V_{PP} = V_{PPH}$ , Block Erase Suspended	1
$V_{IL}$	Input Low Voltage		-0.5	0.8	V		
$V_{IH}$	Input High Voltage		2.0	$V_{CC} + 0.5$	V		
$V_{OL}$	Output Low Voltage			0.45	V	$V_{CC} = V_{CC \text{ MIN.}}$ and $I_{OL} = 5.8 \text{ mA}$	
$V_{OH}^1$	Output High Voltage		$0.85 V_{CC}$		V	$I_{OH} = -2.5 \text{ mA}$ $V_{CC} = V_{CC \text{ MIN.}}$	
$V_{OH}^2$			$V_{CC} - 0.4$		V	$I_{OH} = -100 \mu\text{A}$ $V_{CC} = V_{CC \text{ MIN.}}$	
$V_{PPL}$	$V_{PP}$ during Normal Operations		0.0	5.5	V		
$V_{PPH}$	$V_{PP}$ during Write/Erase Operations	5.0	4.5	5.5	V		
$V_{LKO}$	$V_{CC}$ Erase/Write Lock Voltage		2.0		V		

**NOTES:**

- All currents are in RMS unless otherwise noted. Typical values at  $V_{CC} = 5.0 \text{ V}$ ,  $V_{PP} = 5.0 \text{ V}$ ,  $T = 25^\circ\text{C}$ . These currents are valid for all product versions (package and speeds).
- $I_{CCES}$  is specified with the device de-selected. If the device is read while in erase suspend mode, current draw is the sum of  $I_{CCES}$  and  $I_{CCR}$ .
- Automatic Power Saving (APS) reduces  $I_{CCR}$  to less than 2 mA in Static operation.
- CMOS inputs are either  $V_{CC} \pm 0.2 \text{ V}$  or  $\text{GND} \pm 0.2 \text{ V}$ . TTL Inputs are either  $V_{IL}$  or  $V_{IH}$ .

AC Characteristics - Read Only Operations<sup>1</sup> $T_A = 0^\circ\text{C}$  to  $+70^\circ\text{C}$ 

SYMBOL	PARAMETER	$V_{CC} = 3.3\text{ V} \pm 0.3\text{ V}$		$V_{CC} = 2.7\text{ V} - 3.6\text{ V}$		UNITS	NOTE
		MIN.	MAX.	MIN.	MAX.		
$t_{AVAV}$	Read Cycle Time	120		160		ns	
$t_{AVEL}$	Address Setup to $\overline{CE}$ Going Low	10		10		ns	3, 4
$t_{AVGL}$	Address Setup to $\overline{OE}$ Going Low	0		0		ns	3, 4
$t_{AVQV}$	Address to Output Delay		120		160	ns	
$t_{ELQV}$	$\overline{CE}$ to Output Delay		120		160	ns	2
$t_{PHQV}$	$\overline{RP}$ High to Output Delay		620		650	ns	
$t_{GLQV}$	$\overline{OE}$ to Output Delay		45		45	ns	2
$t_{ELQX}$	$\overline{CE}$ to Output in Low Z	0		0		ns	3
$t_{EHQZ}$	$\overline{CE}$ to Output in High Z		50		50	ns	3
$t_{GLQX}$	$\overline{OE}$ to Output in Low Z	0		0		ns	3
$t_{GHQZ}$	$\overline{OE}$ to Output in High Z		30		30	ns	3
$t_{OH}$	Output Hold from Address, $\overline{CE}$ or $\overline{OE}$ change, whichever occurs first	0		0		ns	3
$t_{FLQV}$ $t_{FHQV}$	$\overline{BYTE}$ to Output Delay		120		160	ns	3
$t_{FLQZ}$	$\overline{BYTE}$ Low to Output in High Z		30		30	ns	3
$t_{ELFL}$ $t_{ELFH}$	$\overline{BYTE}$ High or Low to $\overline{CE}$ Low		5		5	ns	3

AC Characteristics - Read Only Operations<sup>1</sup> Continued $T_A = 0^\circ\text{C}$  to  $+70^\circ\text{C}$ 

SYMBOL	PARAMETER	$V_{CC} = 5.0\text{ V} \pm 0.25\text{ V}$		$V_{CC} = 5.0\text{ V} \pm 0.5\text{ V}$		UNITS	NOTE
		MIN.	MAX.	MIN.	MAX.		
$t_{AVAV}$	Read Cycle Time	70		80		ns	
$t_{AVEL}$	Address Setup to $\overline{CE}$ Going Low	10		10		ns	3, 4
$t_{AVGL}$	Address Setup to $\overline{OE}$ Going Low	0		0		ns	3, 4
$t_{AVQV}$	Address to Output Delay		70		80	ns	
$t_{ELQV}$	$\overline{CE}$ to Output Delay		70		80	ns	2
$t_{PHQV}$	$\overline{RP}$ High to Output Delay		400		480	ns	
$t_{GLQV}$	$\overline{OE}$ to Output Delay		30		35	ns	2
$t_{ELQX}$	$\overline{CE}$ to Output in Low Z	0		0		ns	3
$t_{EHQZ}$	$\overline{CE}$ to Output in High Z		25		30	ns	3
$t_{GLQX}$	$\overline{OE}$ to Output in Low Z	0		0		ns	3
$t_{GHQZ}$	$\overline{OE}$ to Output in High Z		25		30	ns	3
$t_{OH}$	Output Hold from Address, $\overline{CE}$ or $\overline{OE}$ change, whichever occurs first	0		0		ns	3
$t_{FLQV}$ $t_{FHQV}$	$\overline{BYTE}$ to Output Delay		70		80	ns	3
$t_{FLQZ}$	$\overline{BYTE}$ Low to Output in High Z		25		30	ns	3
$t_{ELFL}$ $t_{ELFH}$	$\overline{CE}$ Low to BYTE High or Low		5		5	ns	3

## NOTES:

1. See AC Input/Output Reference Waveforms for timing measurements.
2.  $\overline{OE}$  may be delayed up to  $t_{ELQV} - t_{GLQV}$  after the falling edge of  $\overline{CE}$  without impact on  $t_{ELQV}$ .
3. Sampled, not 100% tested.
4. This timing parameter is used to latch the correct BSR data onto the outputs.

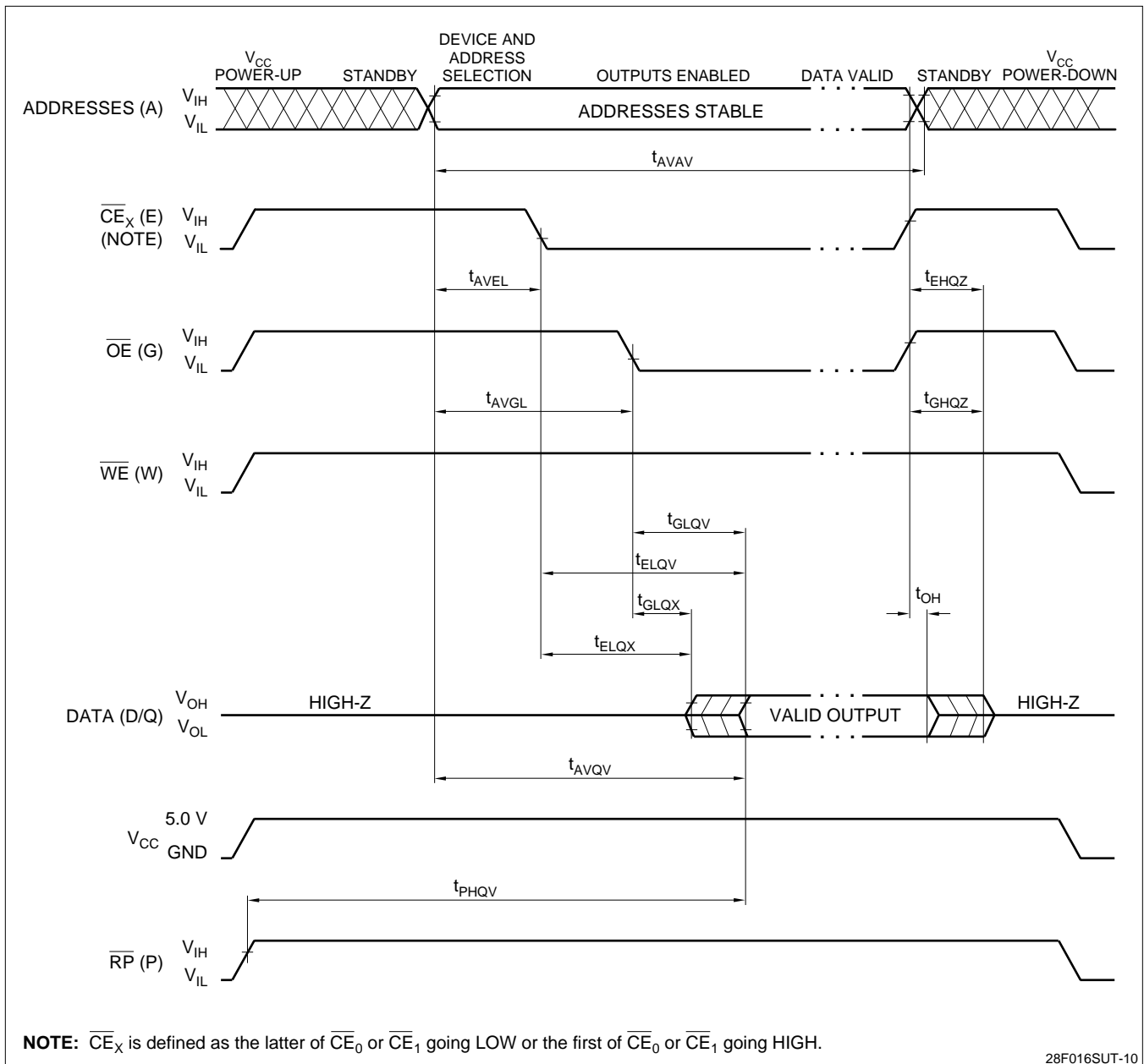
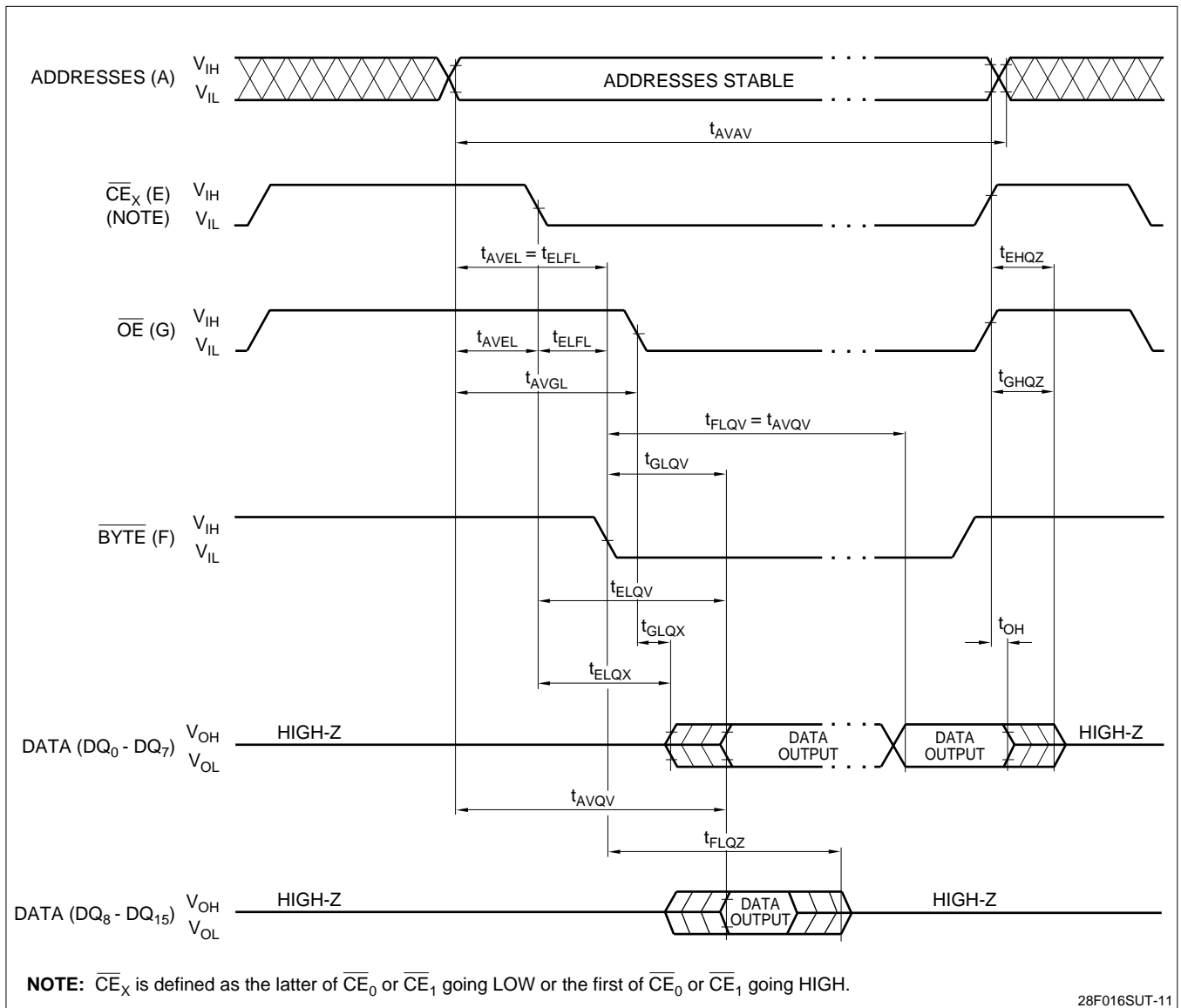


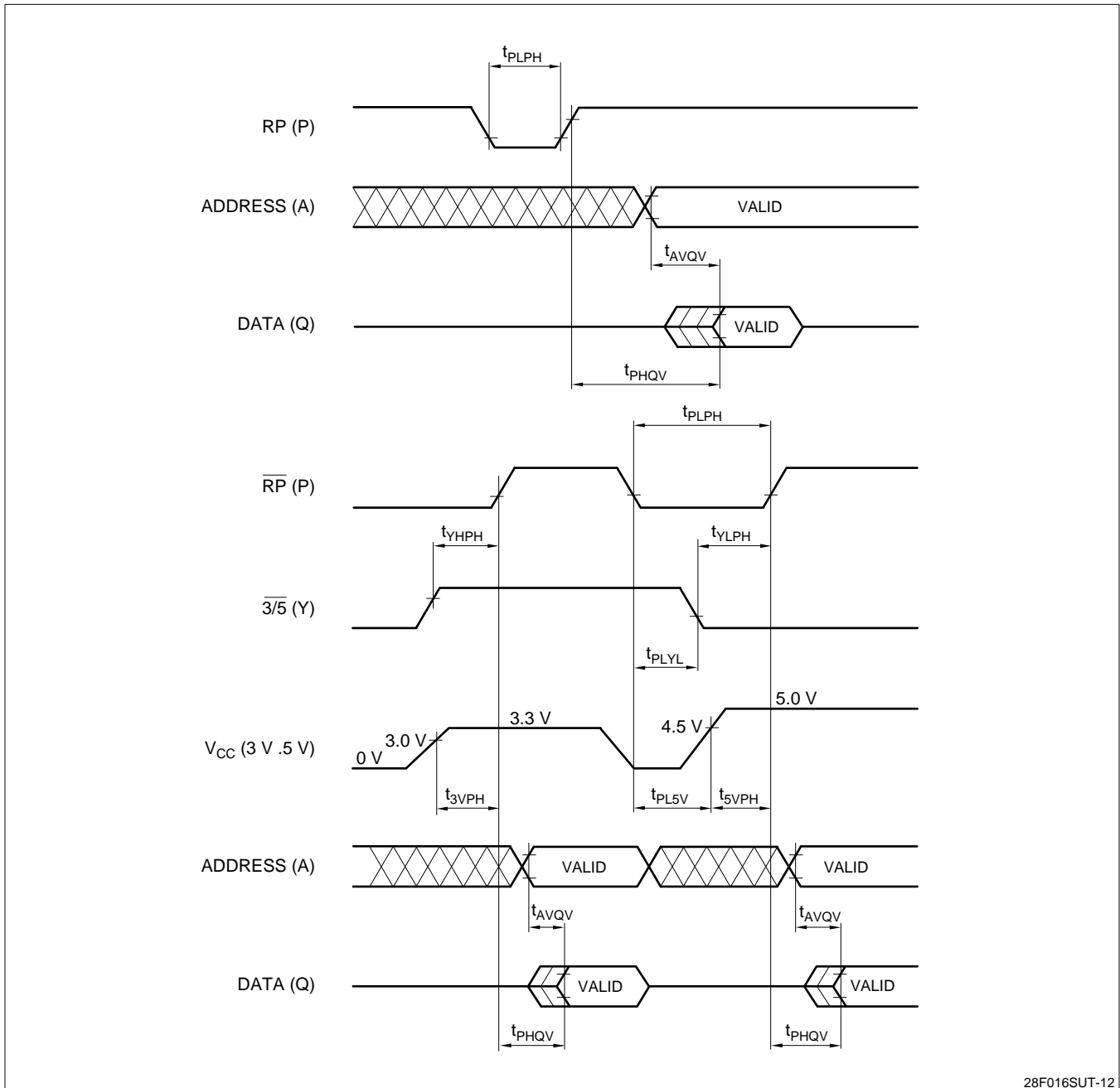
Figure 12. Read Timing Waveforms





28F016SUT-11

Figure 13.  $\overline{BYTE}$  Timing Waveforms



28F016SUT-12

Figure 14.  $V_{CC}$  Power-Up and  $\overline{RP}$  Reset Waveforms

SYMBOL	PARAMETER	MIN.	MAX.	UNIT	NOTE
$t_{PLYL}$ $t_{PLYH}$	$\overline{RP}$ Low to $\overline{3/5}$ Low (High)	0		$\mu\text{s}$	
$t_{YLPH}$ $t_{YHPH}$	$\overline{3/5}$ Low (High) to $\overline{RP}$ High	2		$\mu\text{s}$	1
$t_{PL5V}$ $t_{PL3V}$	$\overline{RP}$ Low to $V_{CC}$ at 4.5 V MIN. (to $V_{CC}$ at 3.0 V min or 3.6 V MAX.)	0		$\mu\text{s}$	2
$t_{PLPH}$	$\overline{RP}$ 'Low'	100		ns	
$t_{5VPH}$	$V_{CC}$ at 4.5 V to $\overline{RP}$ High	100		ns	3
$t_{3VPH}$	$V_{CC}$ at 3.0 V or $\overline{RP}$ High	100		ns	3
$t_{AVQV}$	Address Valid to Data Valid for $V_{CC} = 5 \text{ V} \pm 10\%$		100	ns	4
$t_{PHQV}$	$\overline{RP}$ High to Data Valid for $V_{CC} = 5 \text{ V} \pm 10\%$		480	ns	4

**NOTES:**

$\overline{CE}_0$ ,  $\overline{CE}_1$  and  $\overline{OE}$  are switched low after Power-Up.

1. Minimum of 2  $\mu\text{s}$  is required to meet the specified  $t_{PHQV}$  times.

2. The power supply may start to switch concurrently with  $\overline{RP}$  going Low.

3. The address access time and  $\overline{RP}$  high to data valid time are shown for 5 V  $V_{CC}$  operation.

Refer to the AC Characteristics Read Only Operations 3.3 V  $V_{CC}$  operation and all other speed options.

AC Characteristics for  $\overline{WE}$  - Controlled Command Write Operations<sup>1</sup> $T_A = 0^\circ\text{C}$  to  $+70^\circ\text{C}$ 

SYMBOL	PARAMETER	TYP.	$V_{CC} = 3.3 \pm 0.3 \text{ V}$			NOTE
			MIN.	MAX.	UNITS	
$t_{AVAV}$	Write Cycle Time		120		ns	
$t_{VPWH}$	$V_{PP}$ Setup to $\overline{WE}$ Going High		100		ns	3
$t_{PHEL}$	$\overline{RP}$ Setup to $\overline{CE}$ Going Low		480		ns	
$t_{ELWL}$	$\overline{CE}$ Setup to $\overline{WE}$ Going Low		10		ns	
$t_{AVWH}$	Address Setup to $\overline{WE}$ Going High		75		ns	2, 6
$t_{DVWH}$	Data Setup to $\overline{WE}$ Going High		75		ns	2, 6
$t_{WLWH}$	$\overline{WE}$ Pulse Width		75		ns	
$t_{WHDX}$	Data Hold from $\overline{WE}$ High		10		ns	2
$t_{WHAX}$	Address Hold from $\overline{WE}$ High		10		ns	2
$t_{WHEH}$	$\overline{CE}$ Hold from $\overline{WE}$ High		10		ns	
$t_{WHWL}$	$\overline{WE}$ Pulse Width High		75		ns	
$t_{GHWL}$	Read Recovery before Write		0		ns	
$t_{WHRL}$	$\overline{WE}$ High to $\overline{RY/BY}$ Going Low			100	ns	
$t_{RHPL}$	$\overline{RP}$ Hold from Valid Status Register (CSR, GSR, BSR) Data and $\overline{RY/BY}$ High		0		ns	3
$t_{PHWL}$	$\overline{RP}$ High Recovery to $\overline{WE}$ Going Low		1		$\mu\text{s}$	
$t_{WHGL}$	Write Recovery before Read		120		ns	
$t_{QVVL}$	$V_{PP}$ Hold from Valid Status Register (CSR, GSR, BSR) Data and $\overline{RY/BY}$ High		0		$\mu\text{s}$	
$t_{WHQV}^1$	Duration of Byte Write Operation	12	5		$\mu\text{s}$	4, 5
$t_{WHQV}^2$	Duration of Block Erase Operation		0.3		s	4

AC Characteristics for  $\overline{WE}$  - Controlled Command Write Operations<sup>1</sup> (Continued) $T_A = 0^\circ\text{C}$  to  $+70^\circ\text{C}$ 

SYMBOL	PARAMETER	$V_{CC} = 5.0 \pm 0.25 \text{ V}$			$V_{CC} = 5.0 \pm 0.5 \text{ V}$			UNITS	NOTE
		TYP.	MIN.	MAX.	TYP.	MIN.	MAX.		
$t_{AVAV}$	Write Cycle Time		70			80		ns	
$t_{VPWH}$	$V_{PP}$ Setup to $\overline{WE}$ Going High		100			100		ns	3
$t_{PHEL}$	$\overline{RP}$ Setup to $\overline{CE}$ Going Low		480			480		ns	
$t_{ELWL}$	$\overline{CE}$ Setup to $\overline{WE}$ Going Low		0			0		ns	
$t_{AVWH}$	Address Setup to $\overline{WE}$ Going High		50			50		ns	2, 6
$t_{DVWH}$	Data Setup to $\overline{WE}$ Going High		50			50		ns	2, 6
$t_{WLWH}$	$\overline{WE}$ Pulse Width		40			50		ns	
$t_{WHDX}$	Data Hold from $\overline{WE}$ High		0			10		ns	2
$t_{WHAX}$	Address Hold from $\overline{WE}$ High		10			10		ns	2
$t_{WHEH}$	$\overline{CE}$ Hold from $\overline{WE}$ High		10			10		ns	
$t_{WHWL}$	$\overline{WE}$ Pulse Width High		30			30		ns	
$t_{GHWL}$	Read Recovery before Write		0			0		ns	
$t_{WHRL}$	$\overline{WE}$ High to $\overline{RY}/\overline{BY}$ Going Low			100			100	ns	
$t_{RHPL}$	$\overline{RP}$ Hold from Valid Status Register (CSR, GSR, BSR) Data and $\overline{RY}/\overline{BY}$ High		0			0		ns	3
$t_{PHWL}$	$\overline{RP}$ High Recovery to $\overline{WE}$ Going Low		1			1		$\mu\text{s}$	
$t_{WHGL}$	Write Recovery before Read		60			65		ns	
$t_{QVVL}$	$V_{PP}$ Hold from Valid Status Register (CSR, GSR, BSR) Data and $\overline{RY}/\overline{BY}$ High		0			0		$\mu\text{s}$	
$t_{WHQV}^1$	Duration of Word/Byte Write Operation	8	4.5		8	4.5		$\mu\text{s}$	4, 5
$t_{WHQV}^2$	Duration of Block Erase Operation		0.3			0.3		s	4

**NOTES:**

$\overline{CE}$  is defined as the latter of  $\overline{CE}_0$  or  $\overline{CE}_1$  going Low or the first of  $\overline{CE}_0$  or  $\overline{CE}_1$  going High.

1. Read timing during write and erase are the same as for normal read.
2. Refer to command definition tables for valid address and data values.
3. Sampled, but not 100% tested.
4. Write/Erase durations are measured to valid Status Register (CSR) Data.
5. Word/Byte write operations are typically performed with 1 Programming Pulse.
6. Address and Data are latched on the rising edge of  $\overline{WE}$  for all Command Write Operations.

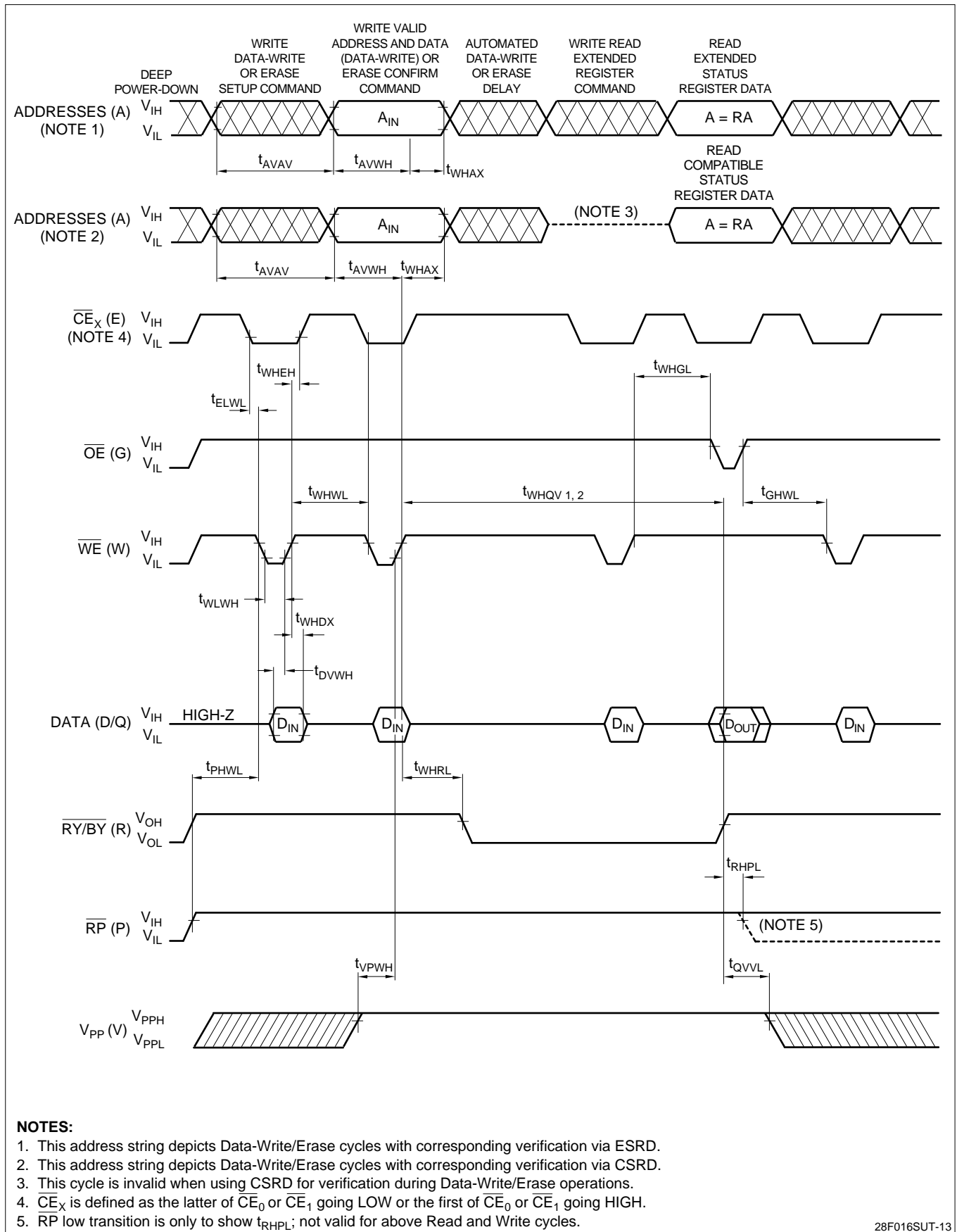


Figure 15. AC Waveforms for Command Write Operations

AC Characteristics for  $\overline{CE}$  - Controlled Command Write Operations<sup>1</sup> $T_A = 0^\circ\text{C}$  to  $+70^\circ\text{C}$ 

SYMBOL	PARAMETER	$V_{CC} = 3.3\text{ V} \pm 0.3\text{ V}$			UNITS	NOTE
		TYP.	MIN.	MAX.		
$t_{AVAV}$	Write Cycle Time		150		ns	
$t_{PHWL}$	$\overline{RP}$ Setup to $\overline{WE}$ Going Low		480		ns	3
$t_{VPEH}$	$V_{PP}$ Set up to $\overline{CE}$ Going High		100		ns	3
$t_{WLEL}$	$\overline{WE}$ Setup to $\overline{CE}$ Going Low		0		ns	
$t_{AVEH}$	Address Setup to $\overline{CE}$ Going High		75		ns	2, 6
$t_{DVEH}$	Data Setup to $\overline{CE}$ Going High		75		ns	2, 6
$t_{ELEH}$	$\overline{CE}$ Pulse Width		75		ns	
$t_{EHDX}$	Data Hold from $\overline{CE}$ High		10		ns	2
$t_{EHAX}$	Address Hold from $\overline{CE}$ High		10		ns	2
$t_{EHWH}$	$\overline{WE}$ Hold from $\overline{CE}$ High		10		ns	
$t_{EHEL}$	$\overline{CE}$ Pulse Width High		75		ns	
$t_{GHEL}$	Read Recovery before Write		0		ns	
$t_{EHRL}$	$\overline{CE}$ High to $\overline{RY}/\overline{BY}$ Going Low			100	ns	
$t_{RHPL}$	$\overline{RP}$ Hold from Valid Status Register (CSR, GSR, BSR) Data and $\overline{RY}/\overline{BY}$ High		0		ns	3
$t_{PHEL}$	$\overline{RP}$ High Recovery to $\overline{CE}$ Going Low		1		$\mu\text{s}$	
$t_{EHGL}$	Write Recovery before Read		120		ns	
$t_{QVVL}$	$V_{PP}$ Hold from Valid Status Register (CSR, GSR, BSR) Data and $\overline{RY}/\overline{BY}$ High		0		$\mu\text{s}$	
$t_{EHQV}^1$	Duration of Byte Write Operation	12	5		$\mu\text{s}$	4, 5
$t_{EHQV}^2$	Duration of Block Erase Operation		0.3		s	4

AC Characteristics for  $\overline{CE}$  - Controlled Command Write Operations<sup>1</sup> (Continued) $T_A = 0^\circ\text{C}$  to  $+70^\circ\text{C}$ 

SYMBOL	PARAMETER	$V_{CC} = 5.0\text{ V} \pm 0.25\text{ V}$			$V_{CC} = 5.0\text{ V} \pm 0.5\text{ V}$			UNITS	NOTE
		TYP.	MIN.	MAX.	TYP.	MIN.	MAX.		
$t_{AVAV}$	Write Cycle Time		70			80		ns	
$t_{PHWL}$	$\overline{RP}$ Setup to $\overline{WE}$ Going Low		480			480		ns	3
$t_{VPEH}$	$V_{PP}$ Set up to $\overline{CE}$ Going High		100			100		ns	3
$t_{WLEL}$	$\overline{WE}$ Setup to $\overline{CE}$ Going Low		0			0		ns	
$t_{AVEH}$	Address Setup to $\overline{CE}$ Going High		50			50		ns	2, 6
$t_{DVEH}$	Data Setup to $\overline{CE}$ Going High		50			50		ns	2, 6
$t_{ELEH}$	$\overline{CE}$ Pulse Width		40			50		ns	
$t_{EHDX}$	Data Hold from $\overline{CE}$ High		0			0		ns	2
$t_{EHAX}$	Address Hold from $\overline{CE}$ High		10			10		ns	2
$t_{EHWH}$	$\overline{WE}$ Hold from $\overline{CE}$ High		10			10		ns	
$t_{EHEL}$	$\overline{CE}$ Pulse Width High		30			50		ns	
$t_{GHEL}$	Read Recovery before Write		0			0		ns	
$t_{EHRL}$	$\overline{CE}$ High to $\overline{RY}/\overline{BY}$ Going Low			100			100	ns	
$t_{RHPL}$	$\overline{RP}$ Hold from Valid Status Register (CSR, GSR, BSR) Data and $\overline{RY}/\overline{BY}$ High		0			0		ns	3
$t_{PHEL}$	$\overline{RP}$ High Recovery to $\overline{CE}$ Going Low		1			1		$\mu\text{s}$	
$t_{EHGL}$	Write Recovery before Read		60			80		ns	
$t_{QVVL}$	$V_{PP}$ Hold from Valid Status Register (CSR, GSR, BSR) Data and $\overline{RY}/\overline{BY}$ High		0			0		$\mu\text{s}$	
$t_{EHQV}^1$	Duration of Byte Write Operation	8	4.5		8	4.5		$\mu\text{s}$	4, 5
$t_{EHQV}^2$	Duration of Block Erase Operation		0.3			0.3		s	4

**NOTES:**

$\overline{CE}$  is defined as the latter of  $\overline{CE}_0$  or  $\overline{CE}_1$  going Low or the first of  $\overline{CE}_0$  or  $\overline{CE}_1$  going High.

1. Read timing during write and erase are the same as for normal read.
2. Refer to command definition tables for valid address and data values.
3. Sampled, but not 100% tested.
4. Write/Erase durations are measured to valid Status Register (CSR) Data.
5. Word/Byte write operations are typically performed with 1 Programming Pulse.
6. Address and Data are latched on the rising edge of  $\overline{CE}$  for all Command Write Operations.



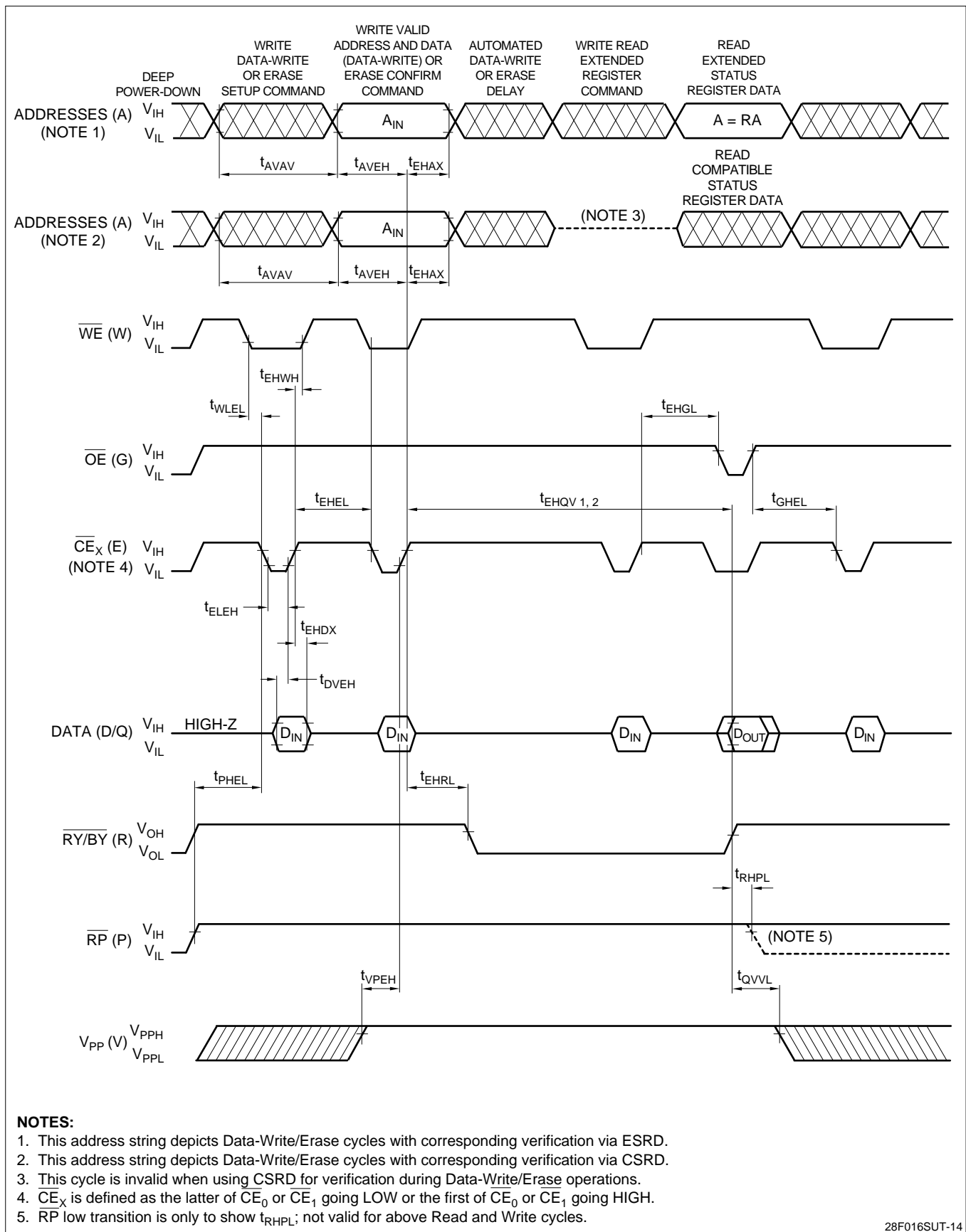


Figure 16. Alternate AC Waveforms for Command Write Operations

AC Characteristics for Page Buffer Write Operations<sup>1</sup> $T_A = 0^\circ\text{C to } +70^\circ\text{C}$ 

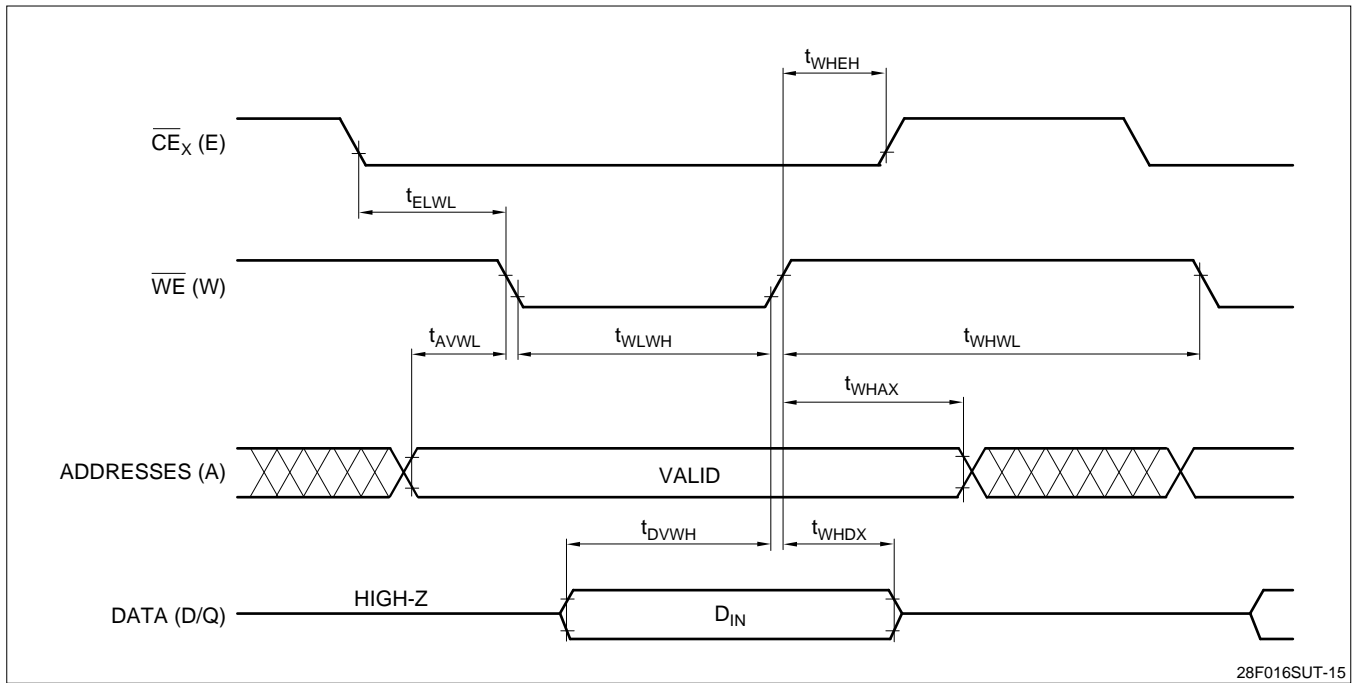
SYMBOL	PARAMETER	$V_{CC} = 3.3\text{ V} \pm 0.3\text{ V}$			UNITS	NOTE
		TYP.	MIN.	MAX.		
$t_{AVAV}$	Write Cycle Time		120		ns	
$t_{ELWL}$	$\overline{CE}$ Setup to $\overline{WE}$ Going Low		10		ns	
$t_{AVWL}$	Address Setup to $\overline{WE}$ Going Low		0		ns	3
$t_{DVWH}$	Data Setup to $\overline{WE}$ Going High		75		ns	2
$t_{WLWH}$	$\overline{WE}$ Pulse Width		75		ns	
$t_{WHDX}$	Data Hold from $\overline{WE}$ High		10		ns	2
$t_{WHAX}$	Address Hold from $\overline{WE}$ High		10		ns	2
$t_{WHEH}$	$\overline{CE}$ Hold from $\overline{WE}$ High		10		ns	
$t_{WHWL}$	$\overline{WE}$ Pulse Width High		45		ns	
$t_{GHWL}$	Read Recovery before Write		0		ns	
$t_{WHGL}$	Write Recovery before Read		95		ns	

SYMBOL	PARAMETER	$V_{CC} = 5.0\text{ V} \pm 0.25\text{ V}$			$V_{CC} = 5.0\text{ V} \pm 0.5\text{ V}$			UNITS	NOTE
		TYP.	MIN.	MAX.	TYP.	MIN.	MAX.		
$t_{AVAV}$	Write Cycle Time		70			80		ns	
$t_{ELWL}$	$\overline{CE}$ Setup to $\overline{WE}$ Going Low		0			0		ns	
$t_{AVWL}$	Address Setup to $\overline{WE}$ Going Low		0			0		ns	3
$t_{DVWH}$	Data Setup to $\overline{WE}$ Going High		50			50		ns	2
$t_{WLWH}$	$\overline{WE}$ Pulse Width		40			50		ns	
$t_{WHDX}$	Data Hold from $\overline{WE}$ High		0			0		ns	2
$t_{WHAX}$	Address Hold from $\overline{WE}$ High		10			10		ns	2
$t_{WHEH}$	$\overline{CE}$ Hold from $\overline{WE}$ High		10			10		ns	
$t_{WHWL}$	$\overline{WE}$ Pulse Width High		30			30		ns	
$t_{GHWL}$	Read Recovery before Write		0			0		ns	
$t_{WHGL}$	Write Recovery before Read		60			65		ns	

**NOTES:**

$\overline{CE}$  is defined as the latter of  $\overline{CE}_0$  or  $\overline{CE}_1$  going Low or the first of  $\overline{CE}_0$  or  $\overline{CE}_1$  going High.

1. These are  $\overline{WE}$  controlled write timings, equivalent  $\overline{CE}$  controlled write timings apply.
2. Sampled, but not 100% tested.
3. Address must be valid during the entire  $\overline{WE}$  Low pulse.



Figuer 17. Page Buffer Write Timing Waveforms

**Erase and Word/Byte Write Performance**

$V_{CC} = 3.3\text{ V} \pm 0.3\text{ V}$ ,  $T_A = 0^\circ\text{C}$  to  $+70^\circ\text{C}$

SYMBOL	PARAMETER	TYP. <sup>(1)</sup>	MIN.	MAX.	UNITS	TEST CONDITIONS	NOTE
$t_{WHRH}^1$	Word/Byte Write Time	12			$\mu\text{s}$		2
$t_{WHRH}^2$	Block Write Time	0.8		2.1	s	Byte Write Mode	2
$t_{WHRH}^3$	Block Write Time	0.4		1.0	s	Word Write Mode	2
	Block Erase Time	0.9		10	s		2
	Full Chip Erase Time	28.8			s		2

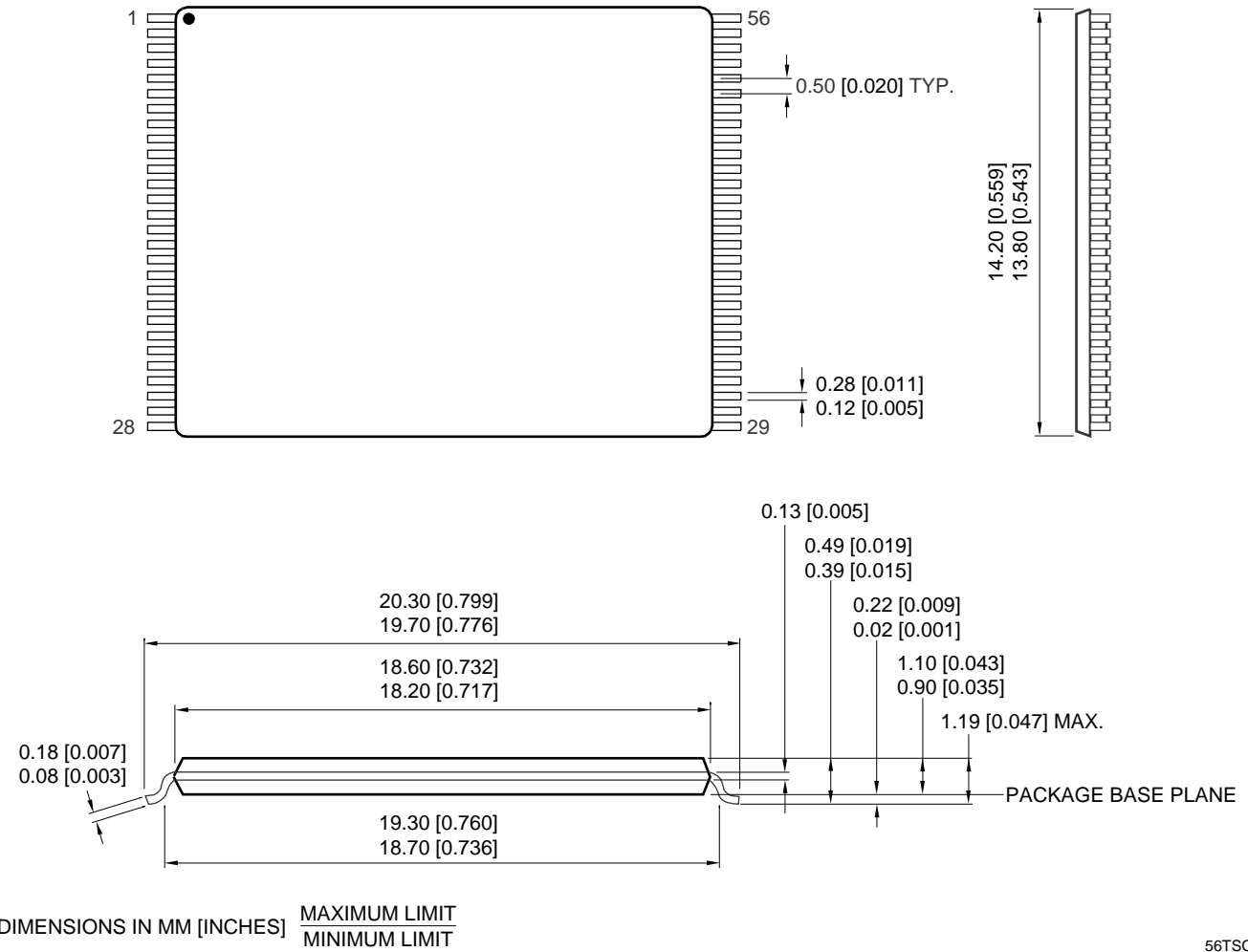
$V_{CC} = 5.0\text{ V} \pm 0.5\text{ V}$ ,  $T_A = 0^\circ\text{C}$  to  $+70^\circ\text{C}$

SYMBOL	PARAMETER	TYP. <sup>(1)</sup>	MIN.	MAX.	UNITS	TEST CONDITIONS	NOTE
$t_{WHRH}^1$	Byte Write Time	8			$\mu\text{s}$		2
$t_{WHRH}^2$	Block Write Time	0.54		2.1	s	Byte Write Mode	2
$t_{WHRH}^3$	Block Write Time	0.27		1.0	s	Word Write Mode	2
	Block Erase Time	0.7		10	s		2
	Full Chip Erase Time	22.4			s		2

**NOTES:**

- 1.  $25^\circ\text{C}$ ,  $V_{PP} = 5.0\text{ V}$ .
- 2. Excludes System-Level Overhead.

56TSOP (TSOP056-P-1420)



56TSOP

ORDERING INFORMATION

LH28F016SU    T    -##  
Device Type    Package    Speed

{ 70 70 ns    Access Time (ns)  
  10 100 ns

56-pin, 1.2 mm x 14 mm x 20 mm TSOP (Type I) (TSOP056-P-1420)

16M (1M x 16, 2M x 8) Flash Memory

Example: LH28F016SUT-70 (16M (1M x 16, 2M x 8) Flash Memory, 70 ns, 56-pin TSOP)

28F016SUT-16

**LIFE SUPPORT POLICY**

SHARP components should not be used in medical devices with life support functions or in safety equipment (or similar applications where component failure would result in loss of life or physical harm) without the written approval of an officer of the SHARP Corporation.

**WARRANTY**

SHARP warrants to Customer that the Products will be free from defects in material and workmanship under normal use and service for a period of one year from the date of invoice. Customer's exclusive remedy for breach of this warranty is that SHARP will either (i) repair or replace, at its option, any Product which fails during the warranty period because of such defect (if Customer promptly reported the failure to SHARP in writing) or, (ii) if SHARP is unable to repair or replace, SHARP will refund the purchase price of the Product upon its return to SHARP. This warranty does not apply to any Product which has been subjected to misuse, abnormal service or handling, or which has been altered or modified in design or construction, or which has been serviced or repaired by anyone other than SHARP. The warranties set forth herein are in lieu of, and exclusive of, all other warranties, express or implied. ALL EXPRESS AND IMPLIED WARRANTIES OF MERCHANTABILITY, FITNESS FOR USE AND FITNESS FOR A PARTICULAR PURPOSE ARE SPECIFICALLY EXCLUDED.

SHARP reserves the right to make changes in specifications at any time and without notice. SHARP does not assume any responsibility for the use of any circuitry described; no circuit patent licenses are implied.

---

**SHARP**<sup>®</sup>**NORTH AMERICA**

SHARP Electronics Corporation  
Microelectronics Group  
5700 NW Pacific Rim Blvd., M/S 20  
Camas, WA 98607, U.S.A.  
Phone: (360) 834-2500  
Telex: 49608472 (SHARPCAM)  
Facsimile: (360) 834-8903  
<http://www.sharpmeg.com>

**EUROPE**

SHARP Electronics (Europe) GmbH  
Microelectronics Division  
SonninstraÙe 3  
20097 Hamburg, Germany  
Phone: (49) 40 2376-2286  
Telex: 2161867 (HEEG D)  
Facsimile: (49) 40 2376-2232

**ASIA**

SHARP Corporation  
Integrated Circuits Group  
2613-1 Ichinomoto-Cho  
Tenri-City, Nara, 632, Japan  
Phone: (07436) 5-1321  
Telex: LABOMETA-B J63428  
Facsimile: (07436) 5-1532