

LI-OV9782-MPI-103H SPECIFICATION

**Rev 1.1
Leopard Imaging Inc.**

Contents

Version History	3
Key Information	4
Pin Assignment	5
Electrical Characteristics	6
1. Absolute Maximum Ratings	6
2. Functional temperature	6
3. DC Characteristics	7
4. Timing Characteristics.....	7
5. SCCB Timing	8
6. Format and Frame rate.....	9
7. Power Up Sequence.....	9
8. Power Down Sequence.....	10
Mechanical Drawing	12



LI-OV9782-MIPI-103H SPECIFICATION

Version History

Version	Description	Release Date
1.0	First Release	10. Oct. 2017
1.1	Update pin assignment	28. Feb. 2018



LI-OV9782-MIPI-103H SPECIFICATION

Key Information

Module Part#		LI-OV9782-MIPI-103H
Sensor Type		OV9782
Array Size		1296 x 816
Power Supply	core	1.2V
	analog	2.8V
	I/O	1.8V
Lens Size		1/4"
F.NO		2.5
FOV		103° (HFOV), 170° (DFOV)
Focal Length		2.0 mm
Focusing Range		30 cm ~ Infinity
TV Distortion		< -88 %
Sensitivity		TBD
Pixel size		3 um x 3 um
IR Cutter		No filter
Sensor Temperature Range	Operating	-30 °C to +85 °C
	Stable Image	0 °C to +50 °C
Output Formats		10-bit RAW
Maximum Image Transfer Rate		1280 x 800: 120fps
Max S/N ratio		TBD
Scan mode		Progressive
Power Requirement	Active	134 mW
	Standby	65 uA
	XSHUTDOWN	50 uA
Interface		MIPI
Color / Mono		Color



LI-OV9782-MIPI-103H SPECIFICATION

Pin Assignment

No.	Name	Pin type	Description
1	SDA	I/O	SCCB data
2	SCL	Input	SCCB input clock
3	DOVDD1.8V	Power	Power for I/O circuit
4	MCP	I/O	MIPI positive clock
5	MCN	I/O	MIPI negative clock
6	DGND	Ground	
7	MDP0	I/O	MIPI positive data [0]
8	MDN0	I/O	MIPI negative data [0]
9	DGND	Ground	
10	MDP1	I/O	MIPI positive data [1]
11	MDN1	I/O	MIPI negative data [1]
12	DGND	Ground	
13	ILPWM	I/O	Mechanical Shutter output indicator
14	GPIO2	I/O	General purpose I/O
15	AGND	Ground	
16	FSIN	I/O	Frame sync input
17	SID	input	SCCB ID select input
18	DVDD1.2V	Power	Power for digital circuit
19	XCLK	Input	System input clock
20	STROBE	I/O	Frame exposure output indicator
21	RESET	Input	Reset and power down (active low with internal pull down resistor)
22	AVDD2.8V	Power	Analog power
23	ULPM	I/O	ALS trigger indicator
24	GND	Ground	



LI-OV9782-MIPI-103H SPECIFICATION

Electrical Characteristics

1. Absolute Maximum Ratings

parameter		absolute maximum rating ^a
ambient storage temperature		-40°C to +125°C
supply voltage (with respect to ground)	V_{DD-A}	4.5V
	V_{DD-D}	3V
	V_{DD-IO}	4.5V
electro-static discharge (ESD)	human body model	2000V
	machine model	200V
all input/output voltages (with respect to ground)		-0.3V to $V_{DD-IO} + 1V$
I/O current on any input or output pin		± 200 mA
peak solder temperature (10 second dwell time)		245°C

- a. exceeding the absolute maximum ratings shown above invalidates all AC and DC electrical specifications and may result in permanent damage to the device. Exposure to absolute maximum rated conditions for extended periods may affect device reliability.

2. Functional temperature

parameter	range
operating temperature ^a	-30°C to +85°C junction temperature
stable image temperature ^b	0°C to 50°C junction temperature

- a. sensor functions but image quality may be noticeably different at temperatures outside of stable image range
b. image quality remains stable throughout this temperature range



LI-OV9782-MIPI-103H SPECIFICATION

3. DC Characteristics ($T_A = 23\text{ }^\circ\text{C} \pm 2\text{ }^\circ\text{C}$)

symbol	parameter	min	typ	max	unit
supply					
V_{DD-A}	supply voltage (analog)	2.6	2.8	3.0	V
V_{DD-IO}	supply voltage (digital I/O)	1.7	1.8	3.0	V
V_{DD-D}	supply voltage (digital core)	1.14	1.2	1.26	V
I_{DD-A}			24		mA
I_{DD-IO}	active (operating) current ^a		2.5		mA
I_{DD-D}			52		mA
$I_{DDS-SCCB}^b$	standby current		65		μA
$I_{DDS-XSHUTDOWN}$			50		μA
digital inputs (typical conditions: AVDD = 2.8V, DVDD = 1.5V, DOVDD = 1.8V)					
V_{IL}	input voltage LOW			0.54	V
V_{IH}	input voltage HIGH	1.26			V
C_{IN}	input capacitor			10	pF
digital outputs (standard loading 25 pF)					
V_{OH}	output voltage HIGH	1.62			V
V_{OL}	output voltage LOW			0.18	V
serial interface inputs					
V_{IL}^c	SIOC and SIOD	-0.5	0	0.54	V
V_{IH}	SIOC and SIOD	1.28	1.8	3.0	V

a. 1280x800 @ 120fps

b. with XVCLK

c. based on DOVDD = 1.8V

4. Timing Characteristics

symbol	parameter	min	typ	max	unit
oscillator and clock input					
f_{OSC}	frequency (XVCLK)	6	24	27	MHz
t_r, t_f	clock input rise/fall time			5 (10 ^a)	ns

a. if using internal PLL



5. SCCB timing

a. SCCB interface timing

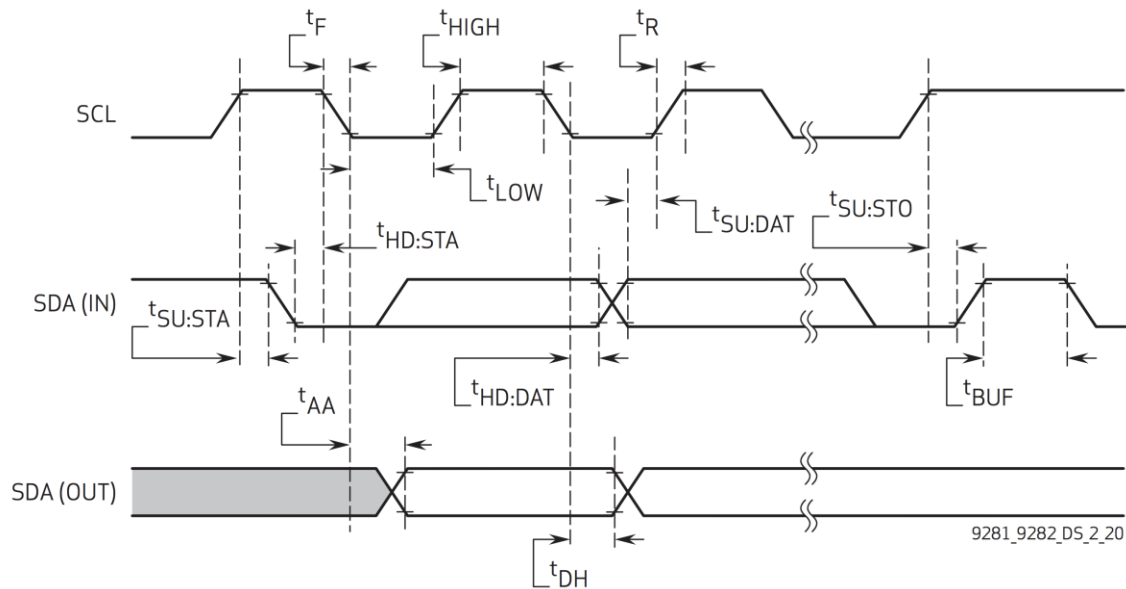

b. SCCB interface timing Specification^{ab}

symbol	parameter	min	typ	max	unit
f_{SCL}	clock frequency			400	kHz
t_{LOW}	clock low period	1.3			μs
t_{HIGH}	clock high period	0.6			μs
t_{AA}	SCL low to data out valid	0.1		0.9	μs
t_{BUF}	bus free time before new start	1.3			μs
$t_{HD:STA}$	start condition hold time	0.6			μs
$t_{SU:STA}$	start condition setup time	0.6			μs
$t_{HD:DAT}$	data in hold time	0			μs
$t_{SU:DAT}$	data in setup time	0.1			μs
$t_{SU:STO}$	stop condition setup time	0.6			μs
t_R, t_F	SCCB rise/fall times			0.3	μs
t_{DH}	data out hold time	0.05			μs

a. SCCB timing is based on 400kHz mode

b. timing measurement shown at the beginning of the rising edge or the end of the falling edge signifies 30%, timing measurement shown in the middle of the rising/falling edge signifies 50%, timing measurement shown at the beginning of the falling edge or the end of the rising edge signifies 70%

6. Format and frame rate

format ^a	resolution ^b	max frame rate	methodology	typical MIPI data rate
full resolution	1280x800	120 fps	full	2-lane @ 800Mbps
720p	1280x720	130 fps	cropping	2-lane @ 800Mbps
VGA	640x480	180 fps	cropping	2-lane @ 800Mbps
640x400	640x400	210 fps	4:1 sub-sampling	2-lane @ 800Mbps

- a. all formats with minimum four dummy lines and four dummy pixels
 b. supports zero row overhead time (ROT) readout

7. Power Up Sequence

a. Power Up Sequence

case	DVDD	XSHUTDOWN	power up sequence requirement
1	external	GPIO	Refer to figure 2-8 1. AVDD rising can occur before or after DOVDD rising as long as they are rising before XSHUTDOWN rising 2. XSHUTDOWN is pulled up after AVDD and DOVDD are stable 3. DVDD rises after DOVDD, but before XSHUTDOWN is pulled high

b. Power Up Sequence timing constraints

constraint	label	min	max	unit
AVDD rising – DOVDD rising	t0	0	∞	ms
DOVDD rising – AVDD rising	t1			ms
AVDD or DOVDD rising, whichever is last – XSHUTDOWN rising	t2	1		ms
XSHUTDOWN rising – first SCCB transaction	t3	8192		XVCLK cycles
minimum number of XVCLK cycles prior to the first SCCB transaction	t4	8192		XVCLK cycles
PLL start up/lock time	t5		0.2	ms
entering streaming mode – first frame start sequence (fixed part)	t6		10	ms
entering streaming mode – first frame start sequence (variable part)	t7	delay is the exposure time value		lines
DOVDD to external DVD rising	t8	0		ms
DOVDD rising to XSHUTDOWN rising	t9	0		ms

Figure 2-8



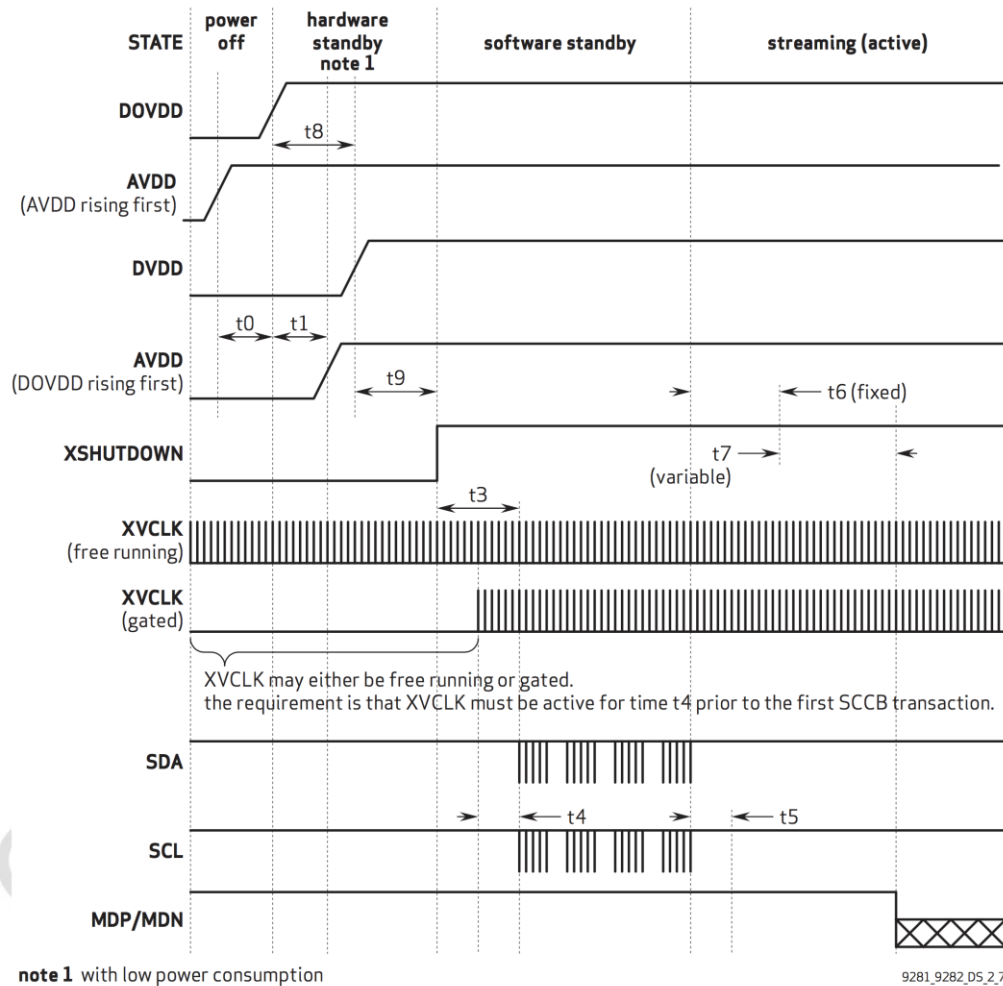

Figure 2-8

8. Power Down Sequence

a. Power Down Sequence

case	DVDD	XSHUTDOWN	power down sequence requirement
1	external	GPIO	Refer to figure 2-9 1. software standby recommended 2. pull XSHUTDOWN low for minimum power consumption 3. pull DVDD low 4. AVDD and DOVDD may fall in any order

b. Power Down Sequence timing constraints

constraint	label	min	max	unit
enter software standby SCCB command device in software standby mode	t0		when a frame of MIPI data is output, wait for the MIPI end code before entering the software for standby; otherwise, enter the software standby mode immediately	
minimum of XVCLK cycles after the last SCCB transaction or MIPI frame end	t1	512		XVCLK cycles
last SCCB transaction or MIPI frame end, XSHUTDOWN falling	t2	512		XVCLK cycles
XSHUTDOWN falling - AVDD falling or DOVDD falling whichever is first	t3	0.0		ms
AVDD falling - DOVDD falling	t4		AVDD and DOVDD may fall in any order, the falling separation can vary from 0 ns to infinity	ms
DOVDD falling - AVDD falling	t5			ms
XSHUTDOWN falling - DVDD falling	t6	0		ms
DVDD falling to DOVDD falling	t7	0		ms

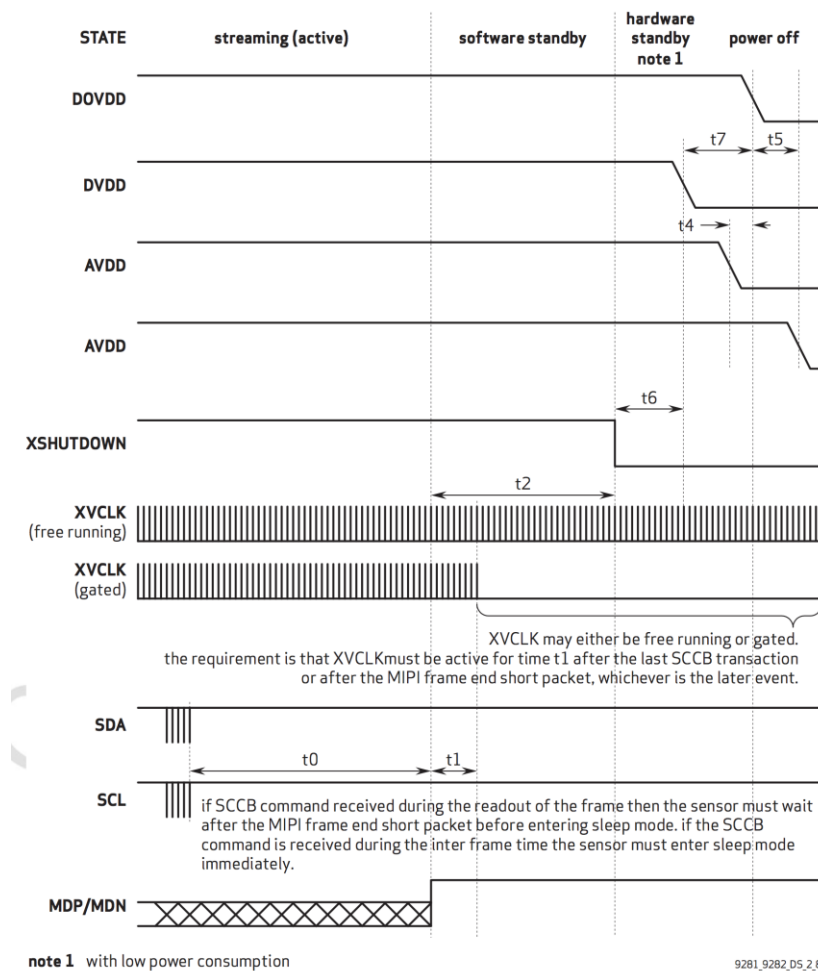

Figure 2-9



