



LL4148 / LL4448

SMALL SIGNAL SWITCHING DIODE

FEATURES

- Silicon epitaxial planar diode
- Fast switching diodes
- 500mw power dissipation
- High temperature soldering guaranteed
250°C/10S at terminals

MECHANICAL DATA

Case: MINI MELF glass sealed envelope.

Terminals: Plated axial leads, solderable per MIL-STD-750, Method 2026

Polarity: Color band denotes cathode end

Mounting Position: Any

Weight: 0.002 ounce, 0.05 grams

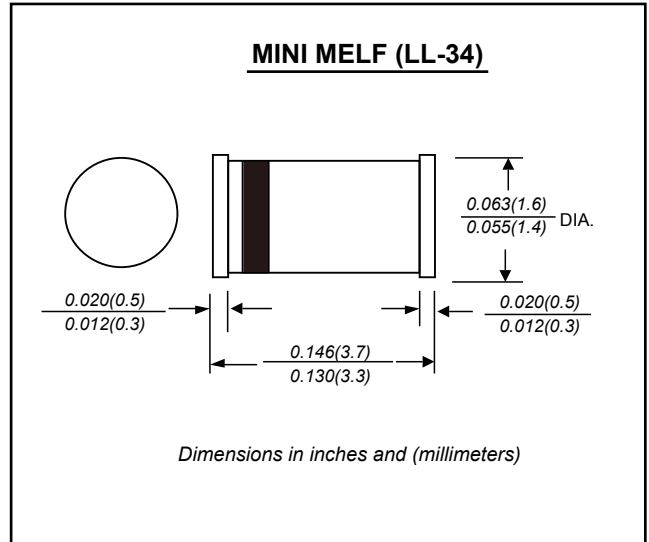

Maximum Ratings ($T_A=25^\circ\text{C}$ Unless otherwise noted)

Characteristic	Symbol	LL4148 / LL4448	Unit
Non-Repetitive Peak Voltage	V_{RM}	100	V
Peak Repetitive Reverse Voltage Working Peak Reverse Voltage DC Blocking Voltage	V_{PWM} V_{RWM} V_R	75	V
Average Rectified Output Current (1)	I_O	150	mA
Non-Repetitive Peak Forward Surge Current @t=1.0us	I_{FSM}	2.0	A
Power Dissipation	P_d	500	mW
Thermal Resistance Junction to Ambient	$R_{\theta JA}$	300	K/W
Operating and Storage Temperature Range	T_J, T_{STG}	-65 to +175	$^\circ\text{C}$

Electrical Characteristics ($T_A=25^\circ\text{C}$ Unless otherwise noted)

Characteristic	Symbol	Min	Max	Unit
Reverse Breakdown Voltage $I_R=100\mu\text{A}$	$V_{(BR)R}$	100	-	V
Forward Voltage LL4148 $I_F=10\text{ mA}$ LL4448 $I_F=5\text{ mA}$ $I_F=100\text{ mA}$	V_F	0.62	1.0 0.72 1.0	V
Leakage Current $V_R=20\text{V}$ $V_R=75\text{V}$ $V_R=75\text{V}, T_j=150^\circ\text{C}$	I_R	- - -	25 5 50	μA
Junction Capacitance	C_j	-	4	PF
Reverse Recovery Time $I_F=10\text{ mA}, I_R=1\text{ mA}, V_R=6\text{V}, R_L=100\Omega$	T_{RR}	-	4	nS

Note: 1. Valid Provided that device Terminals are Kept at Ambient Temperature.



LL4148 / LL4448

RATINGS AND CHARACTERISTIC CURVES

FIG. 1-ADMISSIBLE POWER DISSIPATION VERSUS AMBIENT TEMPERATURE

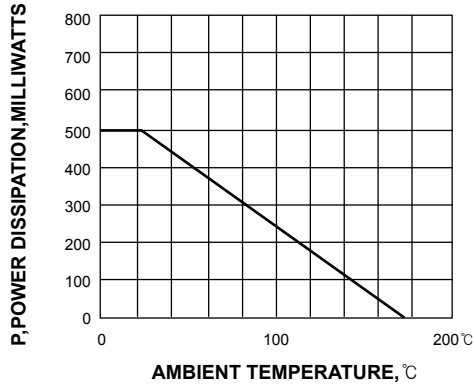

FIG. 2-REVERSE CURRENT VERSUS CONTINUOUS REVERSE VOLTAGE (TYPICAL VALUES)

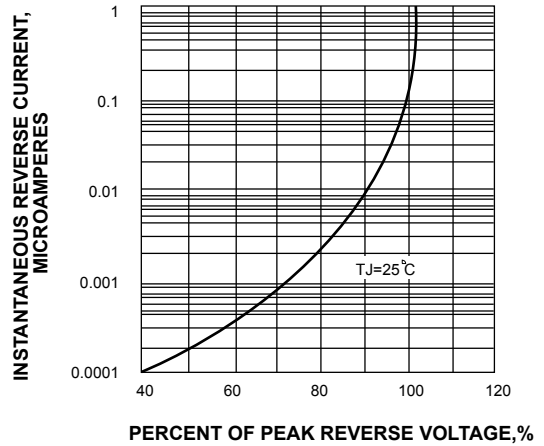

FIG. 3-FORWARD CHARACTERISTICS

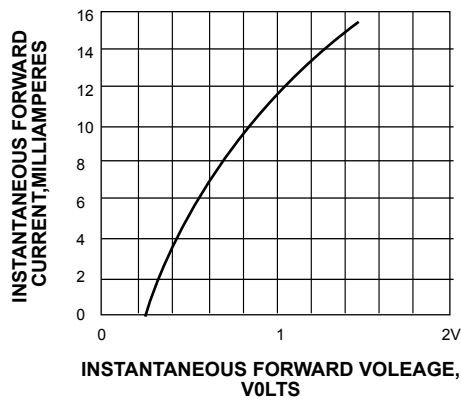

FIG. 4-RELATIVE CAPACTANCE VERSUS REVERSE VOLTAGE

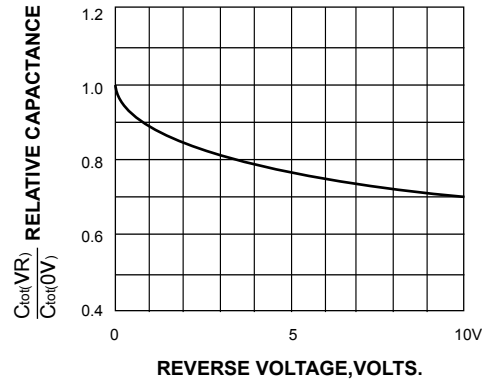

FIG. 5-ADMISSIBLE REPETITIVE PEAK FORWARD CURRENT VERSUS PULSE DURATION

