

Main Product Characteristics:

V_{DSS}	-60V
$R_{DS(on)}$	12m Ω (typ.)
I_D	-60A

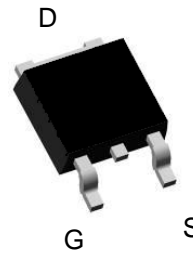

TO-252

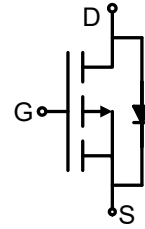

Schematic diagram

Features and Benefits:

- Advanced trench MOSFET process technology
- Special designed for PWM, load switching and general purpose applications
- Ultra low on-resistance with low gate charge
- High Power and current handing capability
- Fully Avalanche Rated

Description:

It utilizes the advanced trench processing techniques to achieve extremely low on resistance and low gate charge. These features combine to make this design an extremely efficient and reliable device for use in PWM, load switching and a wide variety of other applications.

Absolute max Rating:

Symbol	Parameter	Max.	Units
$I_D @ T_C = 25^\circ\text{C}$	Continuous Drain Current, $V_{GS} @ 10\text{V}$ ①	-60	A
$I_D @ T_C = 100^\circ\text{C}$	Continuous Drain Current, $V_{GS} @ 10\text{V}$ ①	-50	
I_{DM}	Pulsed Drain Current②	-240	
I_{SM}	Pulsed Source Current (Body Diode)②	-240	
$P_D @ T_C = 25^\circ\text{C}$	Power Dissipation③	166	W
V_{DS}	Drain-Source Voltage	-60	V
V_{GS}	Gate-to-Source Voltage	± 20	V
E_{AS}	Single Pulse Avalanche Energy @ $L=0.3\text{mH}$	300	mJ
I_{AS}	Single Pulse Avalanche Current @ $L=0.3\text{mH}$	44	A
T_J T_{STG}	Operating Junction and Storage Temperature Range	-55 to + 150	$^\circ\text{C}$

Thermal Resistance

Symbol	Characterizes	Value	Unit
$R_{\theta JA}$	Junction-to-ambient ($t \leq 10s$) ④	62	$^{\circ}C/W$
$R_{\theta JC}$	Maximum Junction-to-Case ⑤	0.75	$^{\circ}C/W$

Electrical Characterizes @ $T_A=25^{\circ}C$ unless otherwise specified

Symbol	Parameter	Min.	Typ.	Max.	Units	Conditions
BV_{DSS}	Drain-to-Source breakdown voltage	-60	—	—	V	$V_{GS} = 0V, I_D = -250\mu A$
$R_{DS(on)}$	Static Drain-to-Source on-resistance	—	12	25	m Ω	$V_{GS} = -10V,$ $I_D = -23A$
		—	22	—		$T_J = 125^{\circ}C$
$V_{GS(th)}$	Gate threshold voltage	-1	—	-3	V	$V_{DS} = V_{GS}, I_D = -250\mu A$
I_{DSS}	Drain-to-Source leakage current	—	—	-1	μA	$V_{DS} = -60V, V_{GS} = 0V$
		—	—	-50		$T_J = 125^{\circ}C$
I_{GSS}	Gate-to-Source forward leakage	—	—	100	nA	$V_{GS} = 20V$
	Gate-to-Source reverse leakage	—	—	-100		$V_{GS} = -20V$
Q_g	Total gate charge	—	—	170	nC	$I_D = -30A,$ $V_{DD} = -40V,$ $V_{GS} = -10V$
Q_{gs}	Gate-to-Source charge	—	—	30		
Q_{gd}	Gate-to-Drain("Miller") charge	—	—	70		
$t_{d(on)}$	Turn-on delay time	—	15.2	—	ns	$V_{DD} = -30V, I_D = -20A,$ $R_L = 1.50\Omega, R_G = 3.00\Omega,$ $V_{GS} = -10V$
t_r	Rise time	—	23.7	—		
$t_{d(off)}$	Turn-Off delay time	—	53.3	—		
t_f	Fall time	—	12.7	—		
C_{iss}	Input capacitance	—	7456	—	pF	$V_{DS} = -25V,$ $V_{GS} = 0V,$ $f = 1MHz$
C_{oss}	Output capacitance	—	376	—		
C_{rss}	Reverse transfer capacitance	—	293	—		

Source-Drain Ratings and Characteristics

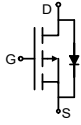
Symbol	Parameter	Min.	Typ.	Max.	Units	Conditions
I_S	Maximum Body-Diode Continuous Current	—	-60	—	A	MOSFET symbol showing the integral reverse p-n junction diode. 
I_{SM}	Maximum Body-Diode Pulse Current	—	-240	—	A	
V_{SD}	Diode Forward Voltage	—	-0.74	-1.2	V	$T_J = 25^{\circ}C, I_S = -10A, V_{GS} = 0V$
t_{rr}	Reverse Recovery Time	—	38.2	—	nS	$T_J = 25^{\circ}C, I_F = -20A, di/dt = 100A/\mu s$
Q_{rr}	Reverse Recovery Charge	—	62.5	—	nC	

Test circuits and Wave forms

EAS Test Circuit:

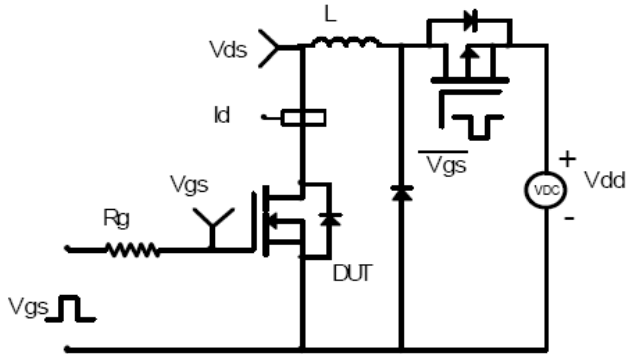

Gate charge test circuit:

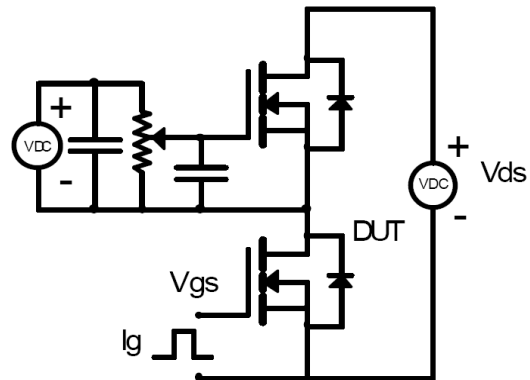

Switching Time Test Circuit:

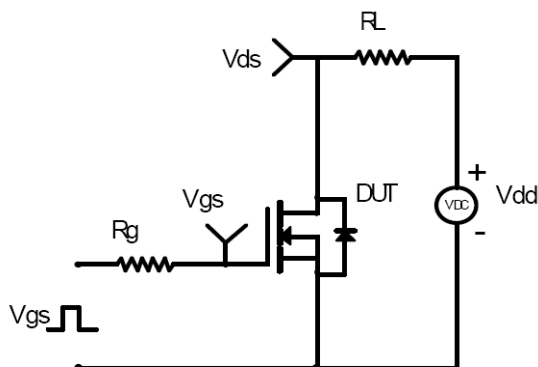

Switching Waveforms:

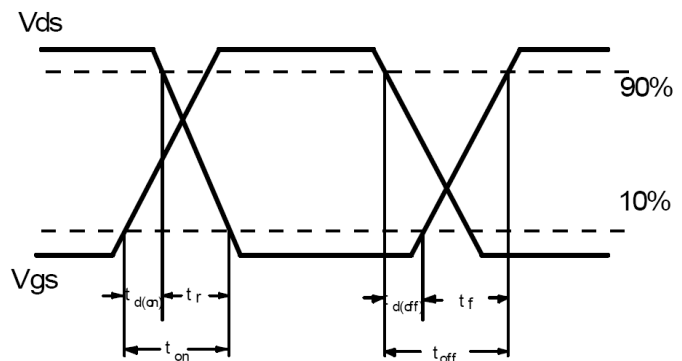

Notes:

- ① Calculated continuous current based on maximum allowable junction temperature.
- ② Repetitive rating; pulse width limited by max. junction temperature.
- ③ The power dissipation P_D is based on max. junction temperature, using junction-to-case thermal resistance.
- ④ The value of $R_{\theta JA}$ is measured with the device mounted on 1 in 2 FR-4 board with 2oz. Copper, in a still air environment with $T_A = 25^\circ\text{C}$

■ TO-252 Package information

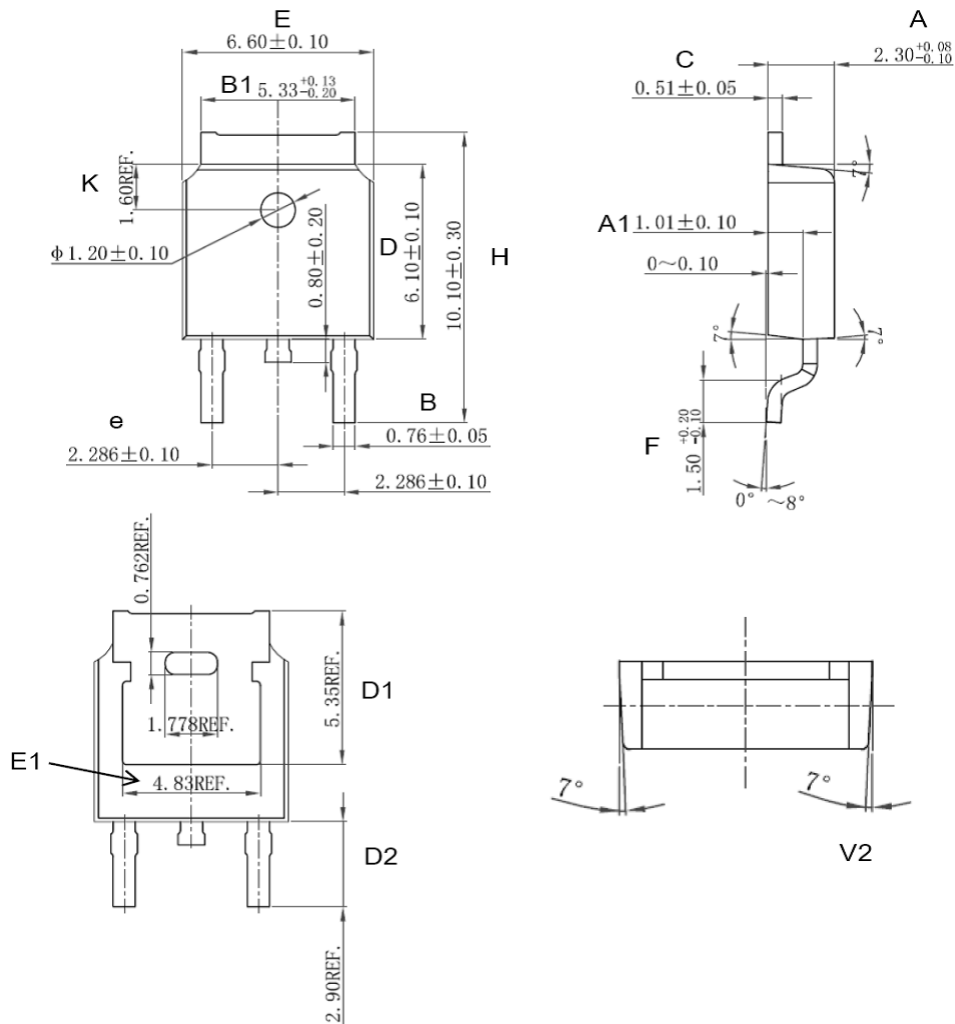

Symbol	Dimension In Millimeters			Dimension In Inches		
	Min	Nom	Max	Min	Nom	Max
A	2.200	2.300	2.380	0.087	0.091	0.094
A1	0.910	1.010	1.110	0.036	0.040	0.044
B	0.710	0.760	0.810	0.028	0.030	0.032
B1	5.130	5.330	5.460	0.202	0.210	0.215
C	0.460	0.510	0.560	0.018	0.020	0.022
D	6.000	6.100	6.200	0.236	0.240	0.244
D1	5.350 (REF)			0.211 (REF)		
D2	2.900 (REF)			0.114 (REF)		
E	6.500	6.600	6.700	0.256	0.260	0.264
E1	4.83 (REF)			0.190 (REF)		
e	2.186	2.286	2.386	0.086	0.090	0.094
H	9.800	10.100	10.400	0.386	0.398	0.409
F	1.400	1.500	1.700	0.055	0.059	0.067
K	1.600 (REF)			0.063 (REF)		
V2	8° (REF)			8° (REF)		

Shanghai Leiditech Electronic Co.,Ltd
 Email: sale1@leiditech.com
 Tel : +86- 021 50828806
 Fax : +86- 021 50477059