

FEATURES

- 20 μ A Supply Current
- 8-Lead SOIC
- 125mA Output Current
- 2.5V Reference
- Reference Output Sources 4mA and Sinks 4mA
- Open Collector
- Comparator Sinks 10mA
- Logic Shutdown
- 0.2V Dropout Voltage
- Thermal Limiting

APPLICATIONS

- Battery Systems
- Battery Backup System
- Portable Terminals
- Portable Instruments
- Memory Keep Alive

DESCRIPTION

The LT1120A is a combination micropower positive regulator and free collector comparator on a single monolithic chip. With only 20 μ A supply current, the LT1120A can supply over 125mA of output current. Input voltage range is from 4.5V to 36V and dropout voltage is 0.6V at 125mA. Dropout voltage decreases with lower load currents. Also included on the chip is a class B output 2.5V reference that can either source or sink current. This allows it to be used as a supply splitter or auxiliary output. A shutdown pin allows logic shutdown of the output.

The comparator can be used for system or battery monitoring. For example, the comparator can be used to warn of low system voltage. Frequency compensation of the comparator for amplifier applications can be obtained by adding external output capacitance.

TYPICAL APPLICATION

5V Regulator

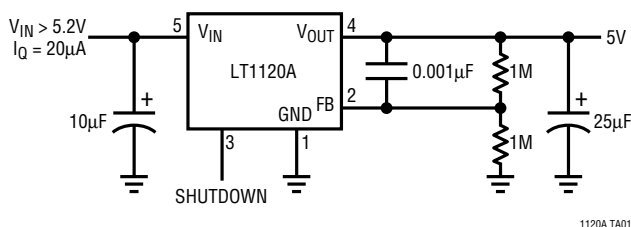

Dropout Voltage and Supply Current

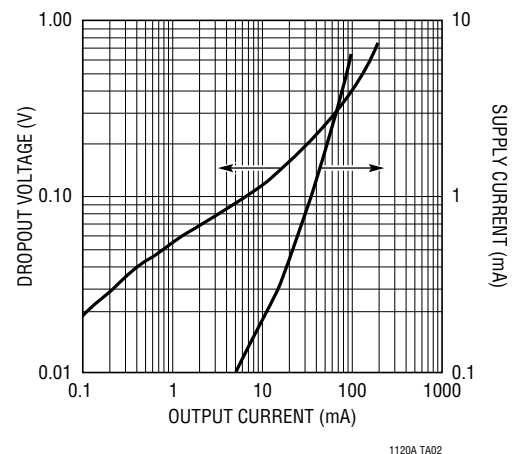

ABSOLUTE MAXIMUM RATINGS

| | |
|-------------------------------------|--------------------|
| Input Voltage | 36V |
| NPN Collector Voltage | 36V |
| Output Short-Circuit Duration | Indefinite |
| Power Dissipation | Internally Limited |
| Operating Temperature Range | |
| LT1120AC | 0°C to 100°C |
| Storage Temperature Range | |
| LT1120AC | -65°C to 150°C |

PACKAGE/ORDER INFORMATION

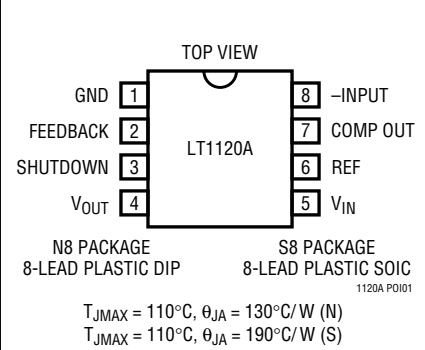
| | |
|--|--------------------------|
|  | ORDER PART NUMBER |
| | LT1120ACN8 LT1120ACS8 |
| | S8 PART MARKING |
| | 1120A |

Consult factory for Industrial and Military grade parts.

ELECTRICAL CHARACTERISTICS $T_J = 25^\circ\text{C}$

| PARAMETER | CONDITIONS | MIN | TYP | MAX | UNITS |
|------------------------|---|------|----------------|----------------|--------------------------------------|
| Reference | | | | | |
| Reference Voltage | $4.5\text{V} \leq V_{IN} \leq 36\text{V}$ | 2.46 | 2.50 | 2.54 | V |
| Line Regulation | $4.5\text{V} \leq V_{IN} \leq 36\text{V}$ | | 0.01 | 0.015 | %/V |
| Load Regulation | $-2.0\text{mA} \leq I_{REF} \leq 2\text{mA}$, $V_{IN} = 12\text{V}$ | | 0.3 | 0.6 | % |
| Output Source Current | $V_{IN} = 5\text{V}$ | 2 | 4 | | mA |
| Output Sink Current | $V_{IN} = 5\text{V}$ | 2 | 4 | | mA |
| Temperature Stability | | | 1 | | % |
| Regulator | | | | | |
| Supply Current | $V_{IN} = 6\text{V}$, $I_{OUT} \leq 100\mu\text{A}$ $V_{IN} = 36\text{V}$, $I_{OUT} \leq 100\mu\text{A}$ $V_{IN} = 12\text{V}$, $I_{OUT} = 125\text{mA}$ | | 20 30 11 | 25 40 20 | μA μA mA |
| Output Current | $(V_{IN} - V_{OUT}) \geq 1\text{V}$, $V_{IN} \geq 6\text{V}$ | 125 | | | mA |
| Load Regulation | $(V_{IN} - V_{OUT}) \geq 1\text{V}$, $V_{IN} \geq 6\text{V}$ | | 0.2 | 0.5 | % |
| Line Regulation | $6\text{V} \leq V_{IN} \leq 36\text{V}$ | | 0.01 | 0.015 | %/V |
| Dropout Voltage | $I_{OUT} = 100\mu\text{A}$ $I_{OUT} = 125\text{mA}$ | | 0.02 0.40 | 0.05 0.65 | V V |
| Feedback Sense Voltage | $V_{IN} = 12\text{V}$ | 2.44 | 2.5 | 2.56 | V |
| Shutdown Pin Voltage | $V_{OUT} \leq 0.5\text{V}$ | | | 0.4 | V |
| | Normal | | | | |
| | Shutdown | 2.2 | 1.4 | | V |
| Shutdown Pin Current | $V_{IN} = 1.4\text{V}$ | | 10 | | μA |
| Feedback Bias Current | | | 15 | 40 | nA |
| Minimum Load Current | $V_{IN} = 36\text{V}$ | | 1 | 5 | μA |
| Short Circuit Current | $V_{IN} = 36\text{V}$ | | 250 | 400 | mA |
| Comparator | | | | | |
| Offset Voltage | $V_{IN} = 36\text{V}$ | | 3 | 7 | mV |
| Bias Current | $V_{IN} = 36\text{V}$ | | 15 | 40 | nA |
| Gain | $\Delta V_{OUT} = 29\text{V}$, $R_L = 20\text{k}$ | 2000 | 10000 | | V/V |
| Power Supply Rejection | $4.5\text{V} \leq V_S \leq 36\text{V}$ | 80 | 96 | | dB |
| Output Sink Current | $V_{IN} = 4.5\text{V}$ | 10 | 18 | | mA |
| Saturation Voltage | $I_{OUT} = 1\text{mA}$ | | 0.4 | 0.6 | V |
| Input Voltage Range | | 0 | | $V_{IN} - 1$ | V |
| Response Time | | | 5 | | μs |
| Leakage Current | $V_{IN} = 36\text{V}$, $V(\text{Pin } 7) = 36\text{V}$ | | | 2 | μA |

ELECTRICAL CHARACTERISTICS

| PARAMETER | CONDITIONS | | MIN | TYP | MAX | UNITS |
|------------------------------|--|---|------|------|------|---------|
| Reference | | | | | | |
| Reference Voltage | $4.5V \leq V_{IN} \leq 36V$ | ● | 2.40 | 2.50 | 2.55 | V |
| Line Regulation | $4.5V \leq V_{IN} \leq 36V$ | ● | | 0.01 | 0.02 | %/V |
| Load Regulation | $-2.0mA \leq I_{REF} \leq 2mA, V_{IN} = 12V$ | ● | | 0.4 | 0.8 | % |
| Output Source Current | $V_{IN} = 5V$ | ● | 2 | | | mA |
| Output Sink Current | $V_{IN} = 5V$ | ● | 2 | | | mA |
| Regulator | | | | | | |
| Supply Current | $V_{IN} = 6V, I_{OUT} \leq 100\mu A$ | ● | | 30 | 40 | μA |
| | $V_{IN} = 36V, I_{OUT} \leq 100\mu A$ | ● | | 40 | 50 | μA |
| | $V_{IN} = 12V, I_{OUT} = 125mA$ | ● | | 11 | 20 | mA |
| Output Current | $(V_{IN} - V_{OUT}) \geq 1V, V_{IN} \geq 6V$ | ● | 125 | | | mA |
| Load Regulation | $(V_{IN} - V_{OUT}) \geq 1V, V_{IN} \geq 6V$ | ● | | | 1 | % |
| Line Regulation | $6V \leq V_{IN} \leq 36V$ | ● | | | 0.02 | %/V |
| Dropout Voltage | $I_{OUT} = 100\mu A$ | ● | | | 0.06 | V |
| | $I_{OUT} = 125mA$ | ● | | | 0.85 | V |
| Feedback Sense Voltage | $V_{IN} = 12V$ | ● | 2.38 | 2.5 | 2.57 | V |
| Feedback Bias Current | | ● | | | 50 | nA |
| Minimum Load Current | $V_{IN} = 36V$ | ● | | | 50 | μA |
| Short Circuit Current | $V_{IN} = 36V$ | ● | | 240 | 400 | mA |
| Comparator | | | | | | |
| Offset Voltage | $V_{IN} = 36V$ | ● | | | 10 | mV |
| Bias Current | $V_{IN} = 36V$ | ● | | 15 | 60 | nA |
| Gain | $\Delta V_{OUT} = 29V, R_L = 20k$ | ● | 1000 | | | V/V |
| Output Sink Current (Note 1) | $V_{IN} = 4.5V$ | ● | 5 | 10 | | mA |
| Leakage Current | $V_{IN} = 36V, V(\text{Pin } 7) = 36V$ | ● | | | 8 | μA |

The ● denotes specifications which apply over the operating temperature range.

Note 1: For $T_A \leq -40^\circ C$ output sink current drops to 2.5mA.

TYPICAL PERFORMANCE CHARACTERISTICS

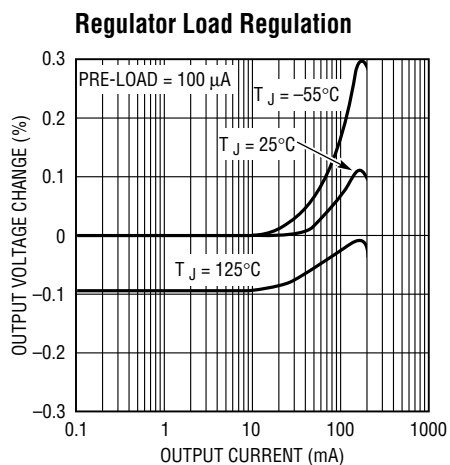

1120A G01

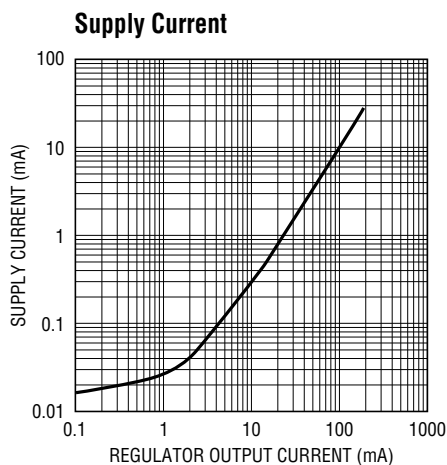

1120A G02

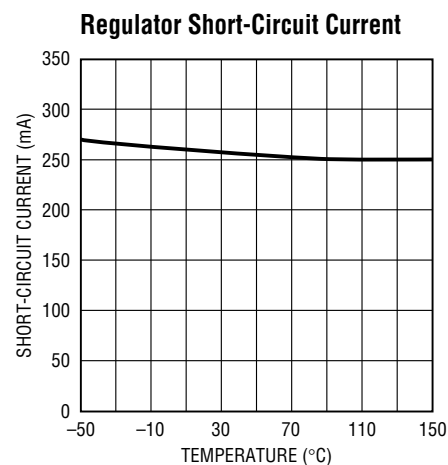

1120A G03

TYPICAL PERFORMANCE CHARACTERISTICS

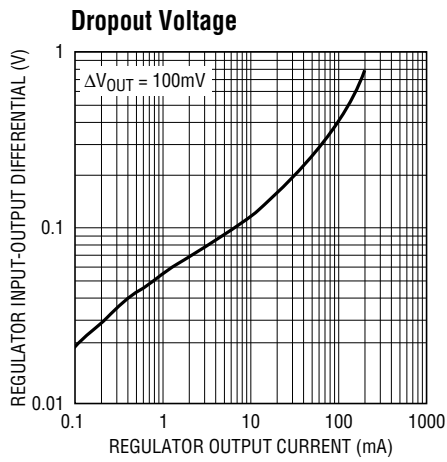

1120A G04

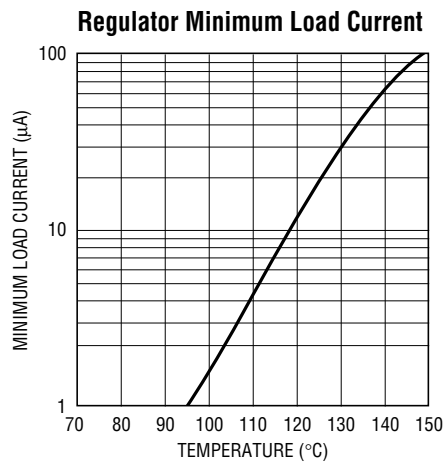

1120A G05

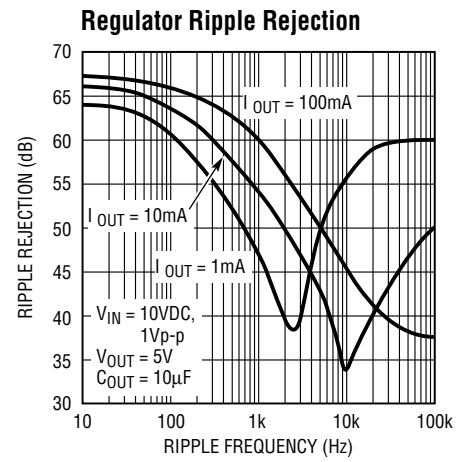

1120A G06

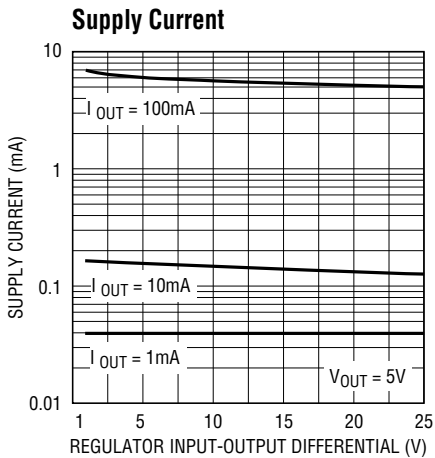

1120A G07

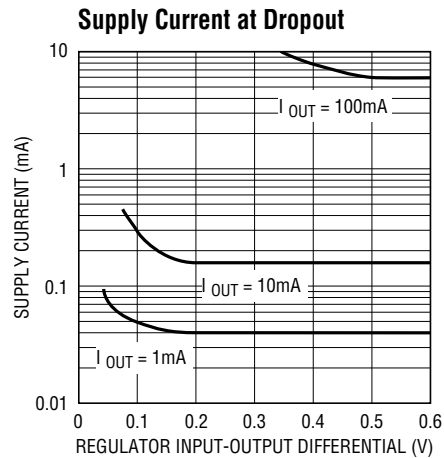

1120A G08

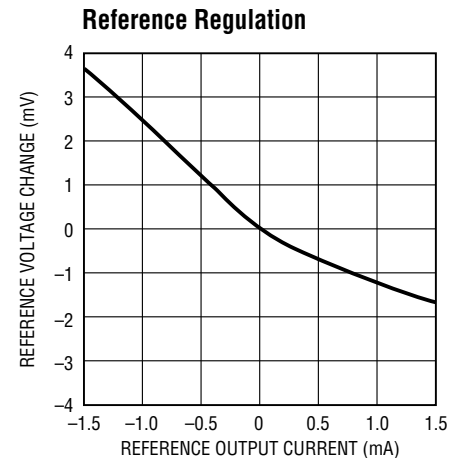

1120A G09

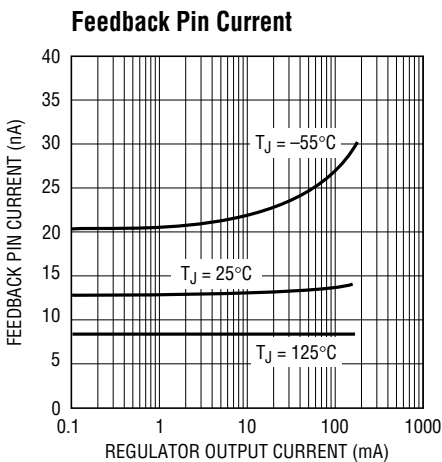

1120A G10

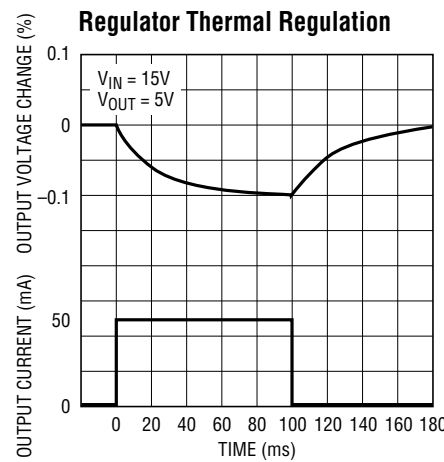

1120A G11

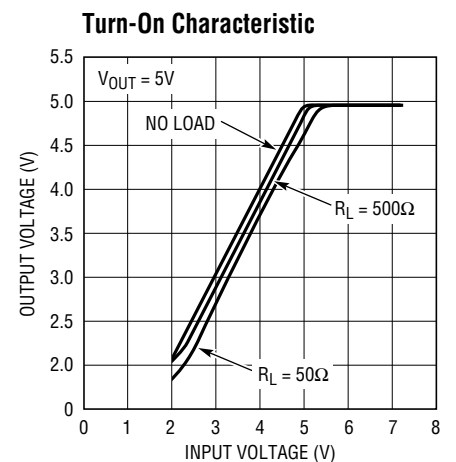

1120A G12

PIN FUNCTIONS

Pin 1 (Ground):

Pin 2 (Feedback): This is the feedback point of the regulator. When operating, it is nominally at 2.5V. Optimum source resistance is 200k to 500k. The feedback pin should not be driven below ground or more positive than 5V.

Pin 3 (Shutdown): A logic 1 shuts off main regulator. Caution: noise or leakage into the shutdown pin can affect output voltage.

Pin 4 (Regulator Output): Main output, requires 10 μ F output capacitor. Can be shorted to V_{IN} or ground without damaging device.

Pin 5 (Input Supply): Bypass with 10 μ F cap. Must always be more positive than ground.

Pin 6 (Reference): 2.5V can source or sink current. May be shorted to ground or up to 5V. Voltages in excess of 5V can damage the device.

Pin 7 (Comparator Output): May be connected to any voltage from ground to 36V more positive than ground (operates above V_{IN}). Short circuit protected.

Pin 8 (Comparator Input): Inverting comparator input.

BLOCK DIAGRAM

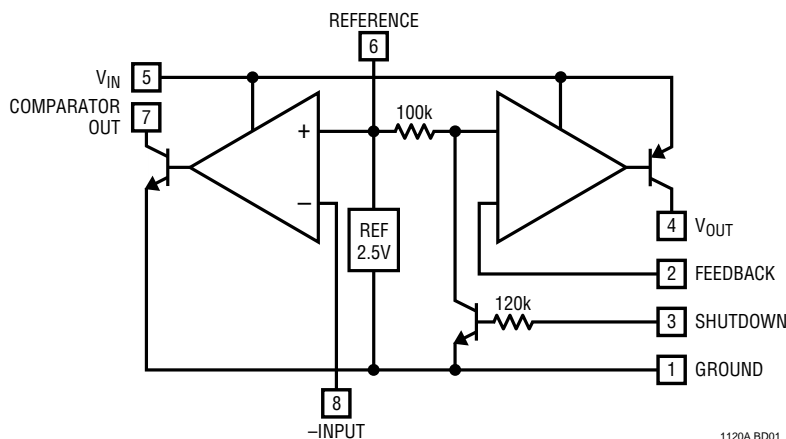

APPLICATIONS INFORMATION

The LT1120A is especially suited for micropower system applications. For example, the comparator section of the LT1120A may be used as a battery checker to provide an indication of low battery. Another type of system application for the LT1120A would be to generate the equivalent of split supplies off of a single power input. The regulator section provides regulated output voltage and the reference, which can both source and sink current is then an artificial system ground providing a split supply for the system.

For many applications the comparator can be frequency compensated to operate as an amplifier. Compensation values for various gains are given in the data sheet. The comparator gain is purposely low to make it easier to frequency compensate as an amplifier. The NPN output is capable of sinking 10mA and can drive loads connected to voltages in excess of the positive power supply. This is useful for driving switches or linear regulators off of a higher input voltage.

APPLICATIONS INFORMATION

Reference

Internal to the LT1120A is a 2.5V trimmed class B output reference. The reference was designed to be able to source or sink current so it could be used in supply splitting applications as well as a general purpose reference for external circuitry. The design of the reference allows it to source and sink typically 4mA. The available source and sink current decreases as temperature increases. It is sometimes desirable to decrease the AC output impedance by placing an output capacitor on Pin 6. The reference in the LT1120A becomes unstable with large capacitive loads placed directly on it. When using an output capacitor, about 20Ω should be used to isolate the capacitor from the reference pin. This 20Ω resistor can be placed directly in series with the capacitor or alternatively the reference line can have 20Ω placed in series with it and then a capacitor to ground. This is shown in Figure 1. Other than placing large capacitive loads on the reference, no other precautions are necessary and the reference is stable with nominal stray capacitances.

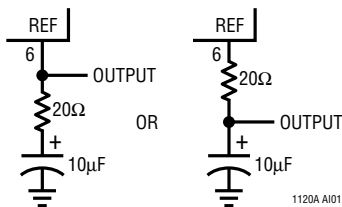

Figure 1. Bypassing Reference

Overload Protection

The main regulator in the LT1120A is current limited at approximately 250mA. The current limit is stable with both input voltage and temperature.

Like most other IC regulators, a minimum load is required on the output of the LT1120A to maintain regulation. For

most standard regulators this is normally specified at 5mA. Of course, for a micropower regulator this would be a tremendously large current. The output current must be large enough to absorb all the leakage current of the pass transistor at the maximum operating temperature. It also affects the transient response; low output currents have long recovery times from load transients. At high operating temperatures the minimum load current increases and having too low of a load current may cause the output to go unregulated. Devices are tested for minimum load current at high temperature. The output voltage setting resistors to the feedback terminal can usually be used to provide the minimum load current.

Frequency Compensation

The LT1120A is frequency compensated by a dominant pole on the output. An output capacitor of $10\mu\text{F}$ is usually large enough to provide good stability. **Increasing the output capacitor above $10\mu\text{F}$ further improves stability.** In order to ensure stability, a feedback capacitor is needed between the output pin and the feedback pin. This is because stray capacitance can form another pole with the large value of feedback resistors used with the LT1120A. Also, a feedback capacitor minimizes noise pickup and improves ripple rejection.

With the large dynamic operating range of the output current, 10000:1, frequency response changes widely. Low AC impedance capacitors are needed to insure stability. While solid tantalum are best, aluminum electrolytics can be used but larger capacitor values may be needed.

TYPICAL APPLICATIONS

Regulator with Output Voltage Monitor

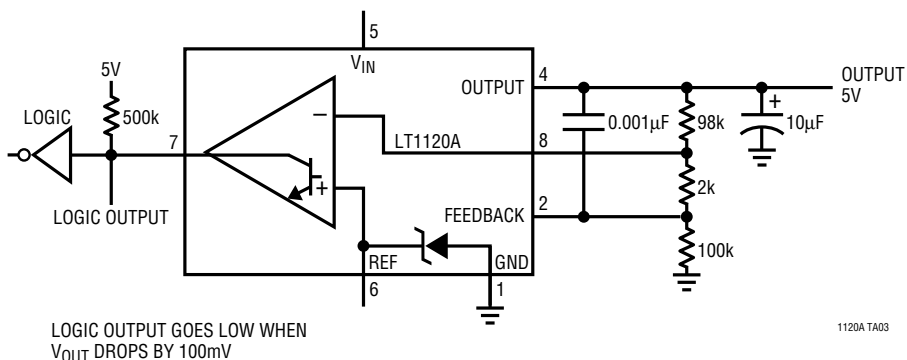

1120A TA03

Compensating the Comparator as an Op Amp

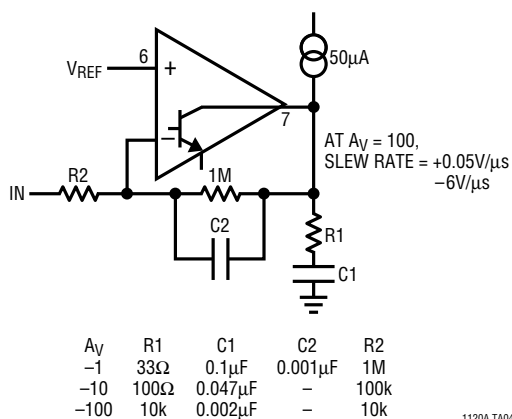

1120A TA04

Current Limited 1 Amp Regulator

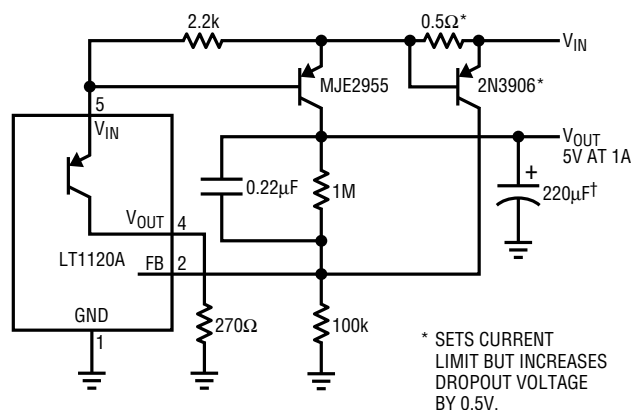

* SETS CURRENT LIMIT BUT INCREASES DROPOUT VOLTAGE BY 0.5V.

† MUST HAVE LOW ESR. SEVERAL 100µF CAPACITORS CAN BE PARALLELED.

1120A TA06

Battery Backup Regulator

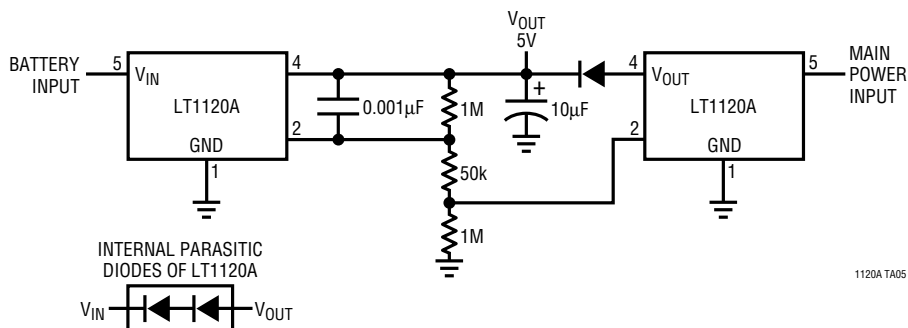

1120A TA05

PACKAGE DESCRIPTION

Dimension in inches (millimeters) unless otherwise noted.

**N8 Package
8-Lead Plastic DIP**

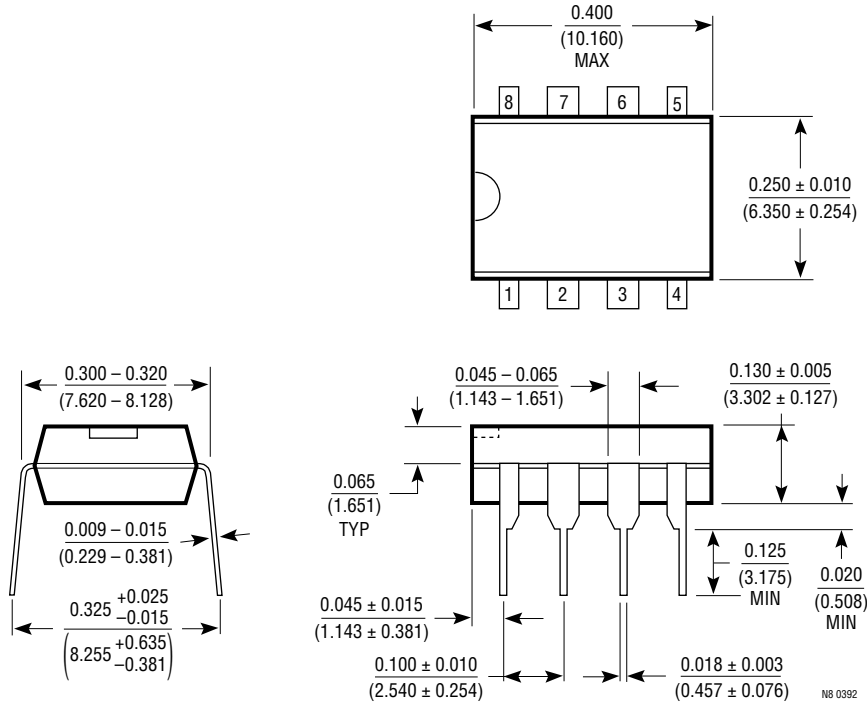

**S8 Package
8-Lead Plastic SOIC (Narrow)**

