

LT1W67A(Under Development)

1616 Size, 0.8mm Thickness, Compact Full Color Leadless Chip LED Device

Outline Dimensions

(Unit : mm)

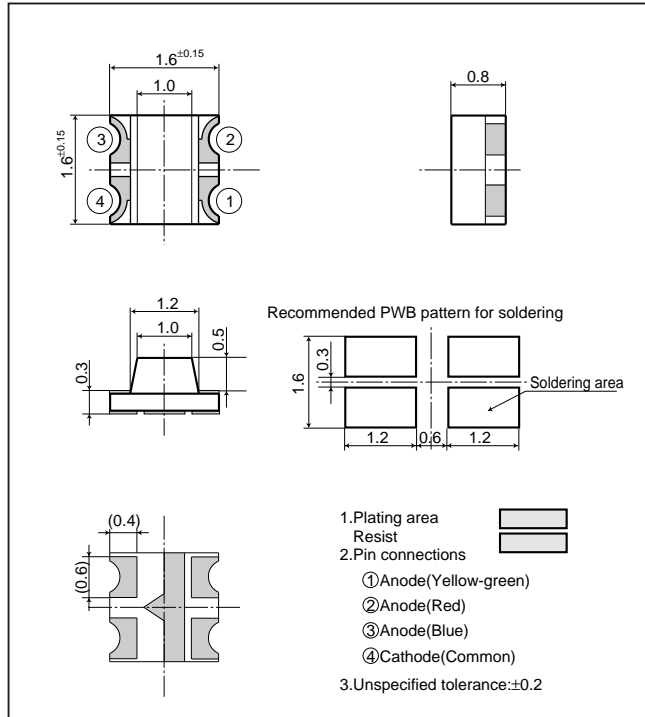

Radiation Diagram

(Ta=25°C)

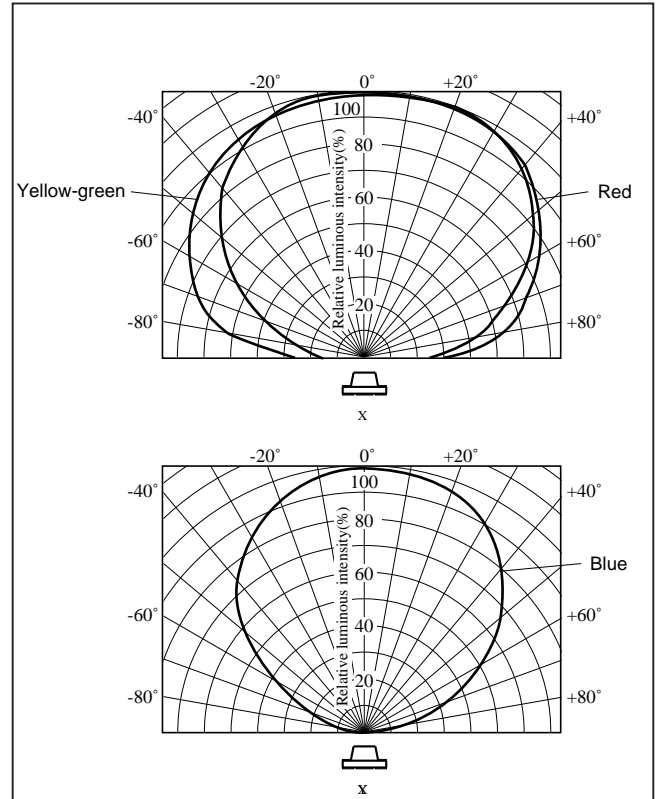

Absolute Maximum Ratings

(Ta=25°C)

Model No.	Radiation color	Radiation material	Power dissipation P ^{*1} (mW)	Forward current I _F (mA)	Peak forward current I _{FM} ^{*2} (mA)	Derating factor (mA/°C)		Reverse voltage V _R (V)	Operating temperature T _{opr} (°C)	Storage temperature T _{stg} (°C)	Soldering temperature T _{sol} ^{*3} (°C)
						DC	Pulse				
LT1W67A	Blue	GaN on SiC	200	30	100	0.67	1.33	5	-30 to +85	-40 to +100	260
	Yellow-green	GaP	84	30	50	0.40	0.67	5	-30 to +85	-40 to +100	260
	Red	GaAsP on GaP	84	30	50	0.40	0.67	5	-30 to +85	-40 to +100	260

*1 The value is specified under the condition that either color is lightened separately.

When all diodes are lightened simultaneously, the power dissipation of each diode should be less than 30% of the value specified in this table.

*2 Duty ratio=1/10, Pulse width=0.1ms

*3 For 3s or less at the temperature of hand soldering. Temperature of reflow soldering is shown on the below page.

Electro-optical Characteristics

(Ta=25°C)

Lens type	Model No.	Radiation color	Forward voltage V _F (V)		Peak emission wavelength		Luminous intensity		Spectrum radiation bandwidth		Reverse current		Terminal capacitance		Page for characteristics diagrams
			TYP	MAX	λ _p (nm) TYP	I _F (mA)	I _v (mcd) TYP	I _F (mA)	Δλ(nm) TYP	I _F (mA)	I _R (μA) MAX	V _R (V)	C _t (pF) TYP	(MHz)	
Milky diffusion	LT1W67A	Blue	4.4	5.6	430	20	6.5	20	70	20	10	4	50	1	—
		Yellow-green	2.1	2.8	565	20	13.0	20	30	20	10	4	35	1	—
		Red	2.0	2.8	635	20	8.5	20	35	20	10	4	20	1	—

(Notice) • In the absence of confirmation by device specification sheets, SHARP takes no responsibility for any defects that may occur in equipment using any SHARP devices shown in catalogs, data books, etc. Contact SHARP in order to obtain the latest device specification sheets before using any SHARP device.

(Internet) • Data for sharp's optoelectronic/power device is provided for internet.(Address <http://www.sharp.co.jp/ecg/>)