

1.3MHz Step-Up DC/DC Converter in SC70 and ThinSOT

FEATURES

- **1.3MHz Switching Frequency**
- **High Output Voltage: Up to 36V**
- **300mA Integrated Switch**
- 12V at 70mA from 5V Input
- 5V at 60mA from 3.3V Input
- Wide Input Range: 2.5V to 16V
- Uses Small Surface Mount Components
- Low Shutdown Current: <math><1\mu\text{A}</math>
- Low Profile (1mm) SC70 and SOT-23 (ThinSOT™) Packages

APPLICATIONS

- Digital Cameras
- CCD Bias Supply
- XDSL Power Supply
- TFT-LCD Bias Supply
- Local 5V or 12V Supply
- Medical Diagnostic Equipment
- Battery Backup

DESCRIPTION

The LT[®]3460 is a general purpose step-up DC/DC converter. The LT3460 switches at 1.3MHz, allowing the use of tiny, low cost and low height capacitors and inductors. The constant frequency results in low, predictable output noise that is easy to filter.

The high voltage switch in the LT3460 is rated at 38V, making the device ideal for boost converters up to 36V. The LT3460 can generate 12V at up to 70mA from a 5V supply.

The LT3460 is available in SC70 and SOT-23 packages.

LT, LTC and LT are registered trademarks of Linear Technology Corporation. ThinSOT is a trademark of Linear Technology Corporation.

TYPICAL APPLICATION

5V to 12V, 70mA Step-Up DC/DC Converter

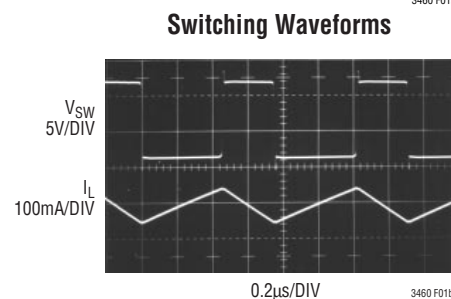
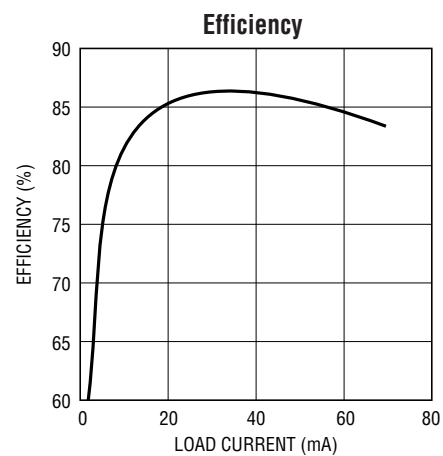
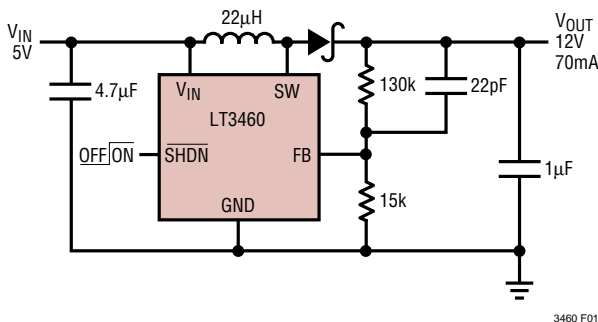

ABSOLUTE MAXIMUM RATINGS (Note 1)

Input Voltage (V_{IN})	16V	Operating Ambient Temperature Range (Note 2)	-40°C to 85°C
SW Voltage	38V	Maximum Junction Temperature	125°C
FB Voltage	5V	Storage Temperature Range	-65°C to 150°C
SHDN Voltage	16V	Lead Temperature (Soldering, 10 sec)	300°C

PACKAGE/ORDER INFORMATION

<p>S5 PACKAGE 5-LEAD PLASTIC TSOT-23</p> <p>$T_{JMAX} = 125^{\circ}C$, $\theta_{JA} = 256^{\circ}C/W$ IN FREE AIR $\theta_{JA} = 120^{\circ}C/W$ ON BOARD OVER GROUND PLANE</p>	ORDER PART NUMBER	<p>S6 PACKAGE 6-LEAD PLASTIC SC70</p> <p>$T_{JMAX} = 125^{\circ}C$, $\theta_{JA} = 400^{\circ}C/W$ IN FREE AIR $\theta_{JA} = 270^{\circ}C/W$ ON BOARD OVER GROUND PLANE</p>	ORDER PART NUMBER
	LT3460ES5		LT3460ESC6
	S5 PART MARKING		SC6 PART MARKING
LTB1	LAAF		

Consult LTC Marketing for parts specified with wider operating temperature ranges.

ELECTRICAL CHARACTERISTICS

The ● denotes the specifications which apply over the full operating temperature range, otherwise specifications are at $T_A = 25^{\circ}C$, $V_{IN} = 3V$, $V_{SHDN} = 3V$, unless otherwise noted.

PARAMETER	CONDITIONS	MIN	TYP	MAX	UNITS
Minimum Operating Voltage		2.5			V
Maximum Operating Voltage				16	V
Feedback Voltage		1.235	1.255	1.275	V
		● 1.225		1.280	V
Feedback Line Regulation	$2.5V < V_{IN} < 16V$		0.015		%/V
FB Pin Bias Current		● 5	25	80	nA
Supply Current	$\overline{SHDN} = 0V$		2.0	3.0	mA
			0.1	0.5	μA
Switching Frequency		1.0	1.3	1.7	MHz
Maximum Duty Cycle		85	90		%
Switch Current Limit		300	420	600	mA
Switch V_{CESAT}	$I_{SW} = 250mA$		320	450	mV
Switch Leakage Current	$V_{SW} = 5V$		0.01	1	μA
SHDN Voltage High		1.5			V
SHDN Voltage Low				0.4	V
SHDN Pin Bias Current			40		μA

Note 1: Absolute Maximum Ratings are those values beyond which the life of a device may be impaired.

Note 2: The LT3460E is guaranteed to meet specifications from 0°C to 70°C. Specifications over the -40°C to 85°C operating temperature range are assured by design, characterization and correlation with statistical process controls.

TYPICAL PERFORMANCE CHARACTERISTICS

Quiescent Current

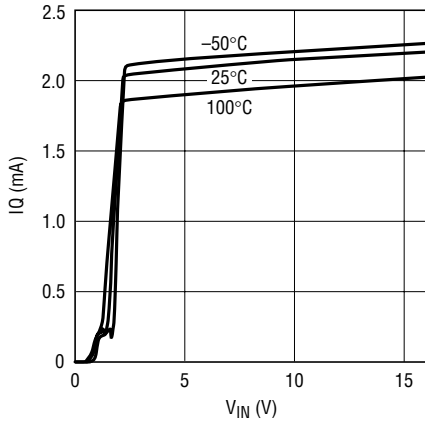

3460 G01

Switching Frequency

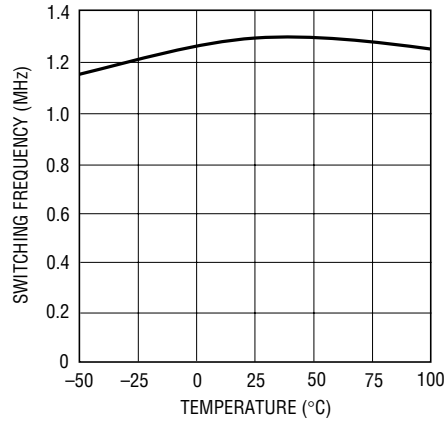

3460 G02

SHDN Pin Bias Current

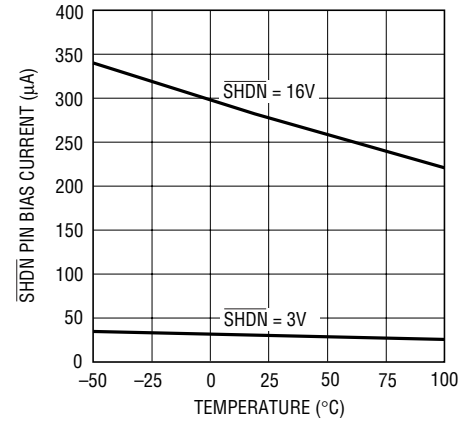

3460 G03

Feedback Bias Current

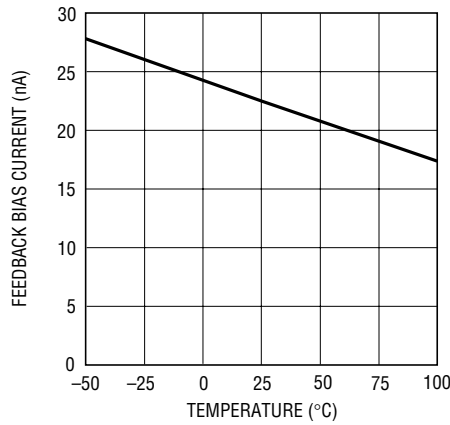

3460 G04

Feedback Voltage

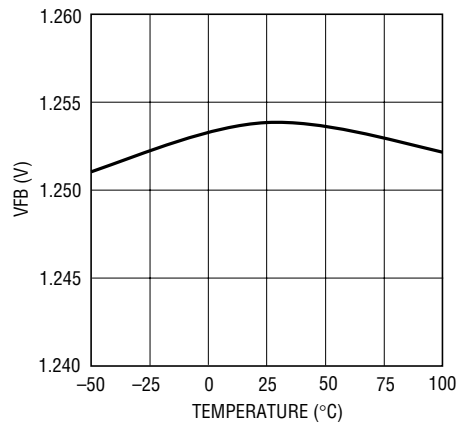

3460 G05

Switch Saturation Voltage (V_{CESAT})

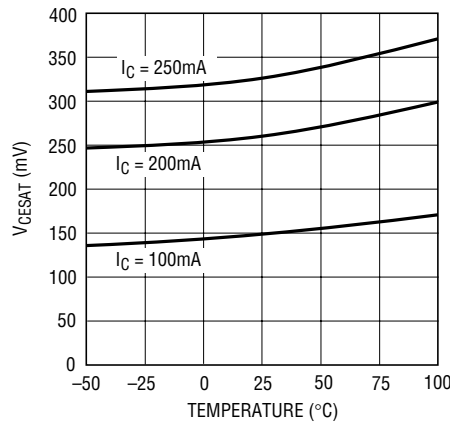

3460 G06

Current Limit vs Duty Cycle

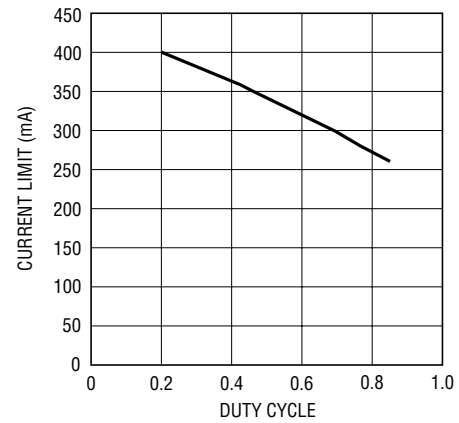

3460 G07

PIN FUNCTIONS (ThinSOT/SC70 Packages)

SW (Pin 1/Pin 1): Switch Pin. Connect inductor/diode here. Minimize trace at this pin to reduce EMI.

GND (Pin 2/Pins 2 and 5): Ground Pin. Tie directly to local ground plane.

FB (Pin 3/Pin 3): Feedback Pin. Reference voltage is 1.255V. Connect resistor divider tap here. Minimize trace area at FB. Set V_{OUT} according to $V_{OUT} = 1.255V (1 + R1/R2)$.

SHDN (Pin 4/Pin 4): Shutdown Pin. Tie to 1.5V or higher to enable device; 0.4V or less to disable device. Also functions as soft-start. Use RC filter (47k, 47nF typ) as shown in Figure 1.

V_{IN} (Pin 5/Pin 6): Input Supply Pin. Must be locally bypassed.

BLOCK DIAGRAM

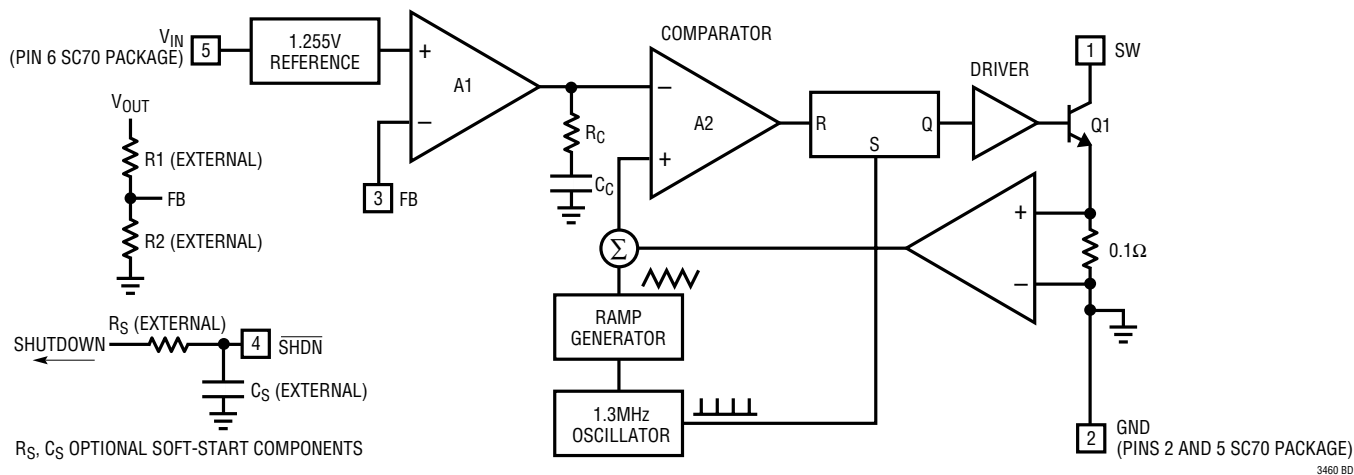

Figure 1. Block Diagram

OPERATION

The LT3460 uses a constant frequency, current mode control scheme to provide excellent line and load regulation. Operation can be best understood by referring to the block diagram in Figure 1. At the start of each oscillator cycle, the SR latch is set, which turns on the power switch Q1. A voltage proportional to the switch current is added to a stabilizing ramp and the resulting sum is fed into the positive terminal of the PWM comparator A2. When this voltage exceeds the level at the negative input of A2, the SR

latch is reset turning off the power switch. The level at the negative input of A2 is set by the error amplifier A1, and is simply an amplified version of the difference between the feedback voltage and the reference voltage of 1.255V. In this manner, the error amplifier sets the correct peak current level to keep the output in regulation. If the error amplifier's output increases, more current is delivered to the output; if it decreases, less current is delivered.

OPERATION

Feedback Loop Compensation

The LT3460 has an internal feedback compensation network as shown in Figure 1 (R_C and C_C). However, because the small signal characteristics of a boost converter change with operation conditions, the internal compensation network cannot satisfy all applications. A properly designed external feed forward capacitor from V_{OUT} to FB (C_F in Figure 2) will correct the loop compensation for most applications.

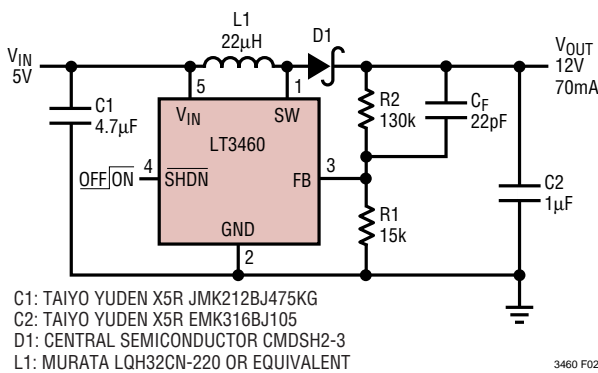

Figure 2. 5V to 12V Step-Up Converter

The LT3460 uses peak current mode control. The current feedback makes the inductor very similar to a current source in the medium frequency range. The power stage transfer function in the medium frequency range can be approximated as:

$$G_P(s) = \frac{K1}{s \cdot C2}$$

where $C2$ is the output capacitance, and $K1$ is a constant based on the operating point of the converter. In continuous current mode, $K1$ increases as the duty cycle decreases.

The internal compensation network R_C , C_C can be approximated as follows in medium frequency range:

$$G_C(s) = K2 \cdot \frac{s \cdot R_C \cdot C_C + 1}{s \cdot C_C}$$

The zero

$$f_z = \frac{1}{2 \cdot \pi \cdot R_C \cdot C_C}$$

is about 70kHz.

The feedback loop gain $T(s) = K3 \cdot G_P(s) \cdot G_C(s)$. If it crosses over 0dB far before f_z , the phase margin will be small. Figure 3 is the Bode plot of the feedback loop gain measured from the converter shown in Figure 2 without the feedforward capacitor C_F . The result agrees with the previous discussion: Phase margin of about 20° is insufficient.

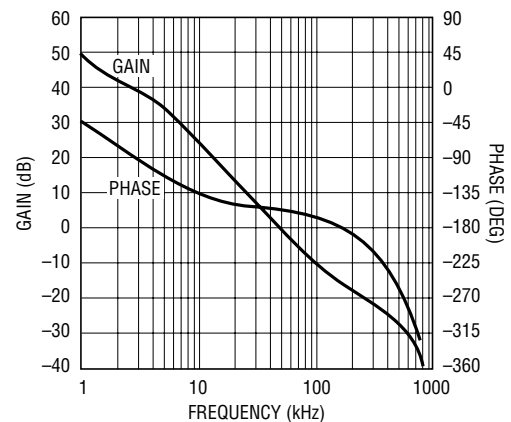

Figure 3

In order to improve the phase margin, a feed-forward capacitor C_F in Figure 2 can be used.

Without the feed-forward capacitor, the transfer function from V_{OUT} to FB is:

$$\frac{FB}{V_{OUT}} = \frac{R1}{R1 + R2}$$

With the feed-forward capacitor C_F , the transfer function becomes:

$$\frac{FB}{V_{OUT}} = \frac{R1}{R1 + R2} \cdot \frac{s \cdot R2 \cdot C_F + 1}{s \cdot \frac{R1 \cdot R2}{R1 + R2} \cdot C_F + 1}$$

The feed-forward capacitor C_F generates a zero and a pole. The zero always appears before the pole. The frequency distance between the zero and the pole is determined only by the ratio between V_{OUT} and FB. To give maximum phase

OPERATION

margin, C_F should be chosen so that the midpoint frequency between the zero and the pole is at the cross over frequency.

With $C_F = 20\text{pF}$, the feedback loop Bode plot is reshaped as shown in Figure 4. The phase margin is about 60° .

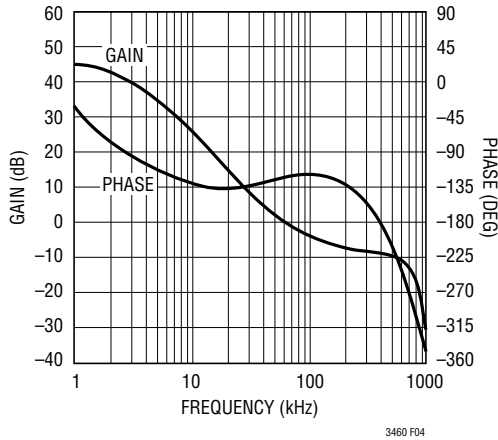

Figure 4.

The feed-forward capacitor increases the gain at high frequency. The feedback loop therefore needs to have enough attenuation at the switching frequency to reject the switching noise. Additional internal compensation components have taken this into consideration.

For most of the applications of LT3460, the output capacitor ESR zero is at very high frequency and can be ignored. If a low frequency ESR zero exists, for example, when a high-ESR Tantalum capacitor is used at the output, the phase margin may be enough even without a feed-forward capacitor. In these cases, the feed-forward capacitor should not be added because it may cause the feedback loop to not have enough attenuation at the switching frequency.

Layout Hints

The high speed operation of the LT3460 demands careful attention to board layout. You will not get advertised performance with careless layout. Figure 5 shows the recommended component placement.

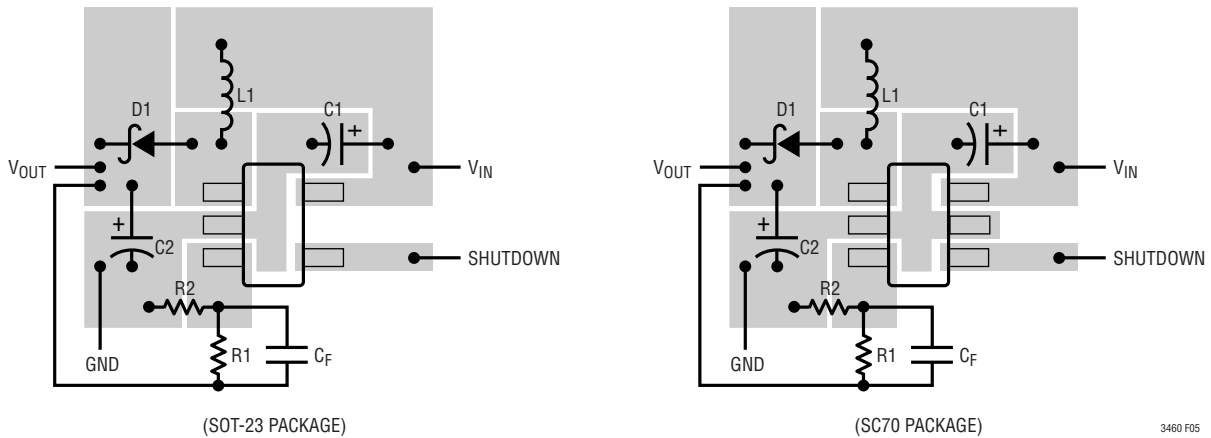
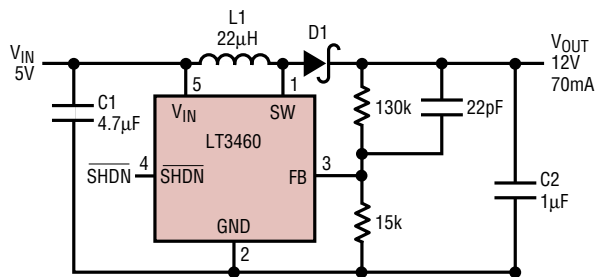

Figure 5. Suggested Layout

TYPICAL APPLICATIONS

5V to 12V Step-Up Converter



- C1: TAIYO YUDEN X5R JMK212BJ475
- C2: TAIYO YUDEN X5R EMK212BJ105
- D1: CENTRAL SEMICONDUCTOR CMDSH2-3
- L1: MURATA LQH32CN-220 OR EQUIVALENT

3460 TA01

Efficiency

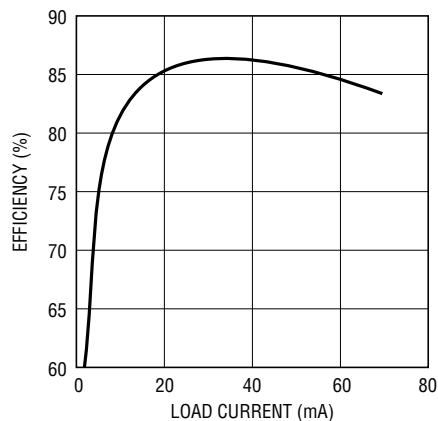

3460 TA01a

Load Step Response

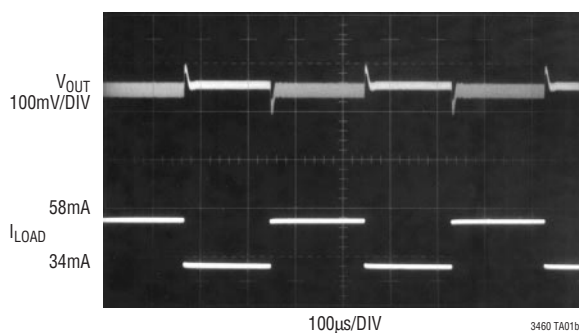

100µs/DIV

3460 TA01b

5V to 12V with Soft-Start Circuit

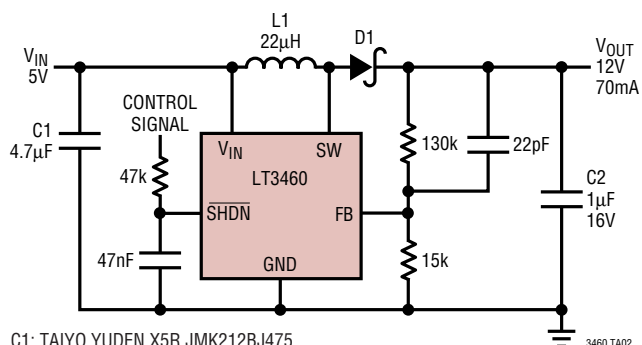

- C1: TAIYO YUDEN X5R JMK212BJ475
- C2: TAIYO YUDEN X5R EMK212BJ105
- D1: CENTRAL SEMICONDUCTOR CMDSH2-3
- L1: MURATA LQH32CN-220 OR EQUIVALENT

3460 TA02

Input Current and Output Voltage

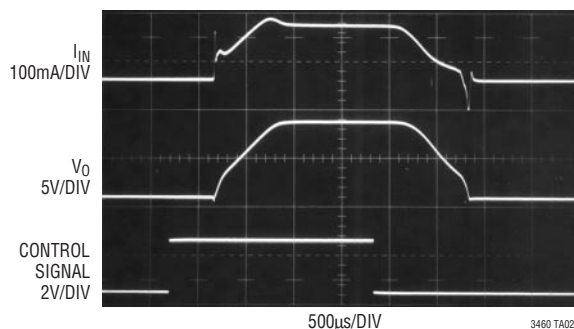

500µs/DIV

3460 TA02b

TYPICAL APPLICATIONS

3.3V to 12V Step-Up Converter

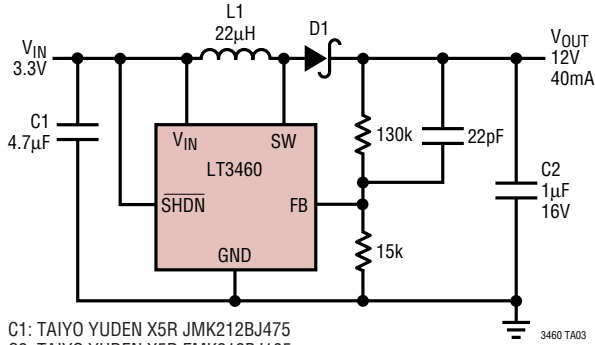

C1: TAIYO YUDEN X5R JMK212BJ475
 C2: TAIYO YUDEN X5R EMK212BJ105
 D1: CENTRAL SEMICONDUCTOR CMDSH2-3
 L1: MURATA LQH32CN-220 OR EQUIVALENT

3460 TA03

Efficiency

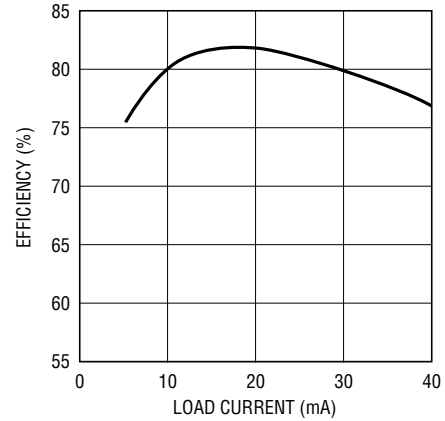

3460 TA03a

Li-Ion to 5V Step-Up Converter

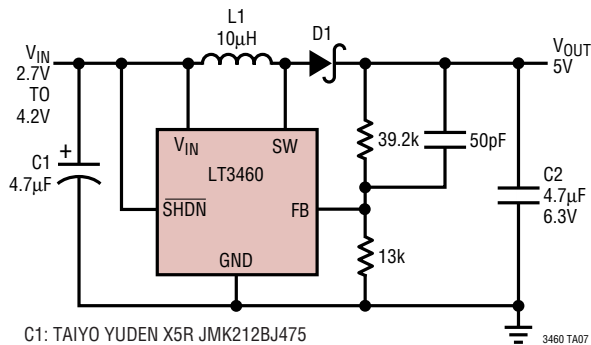

C1: TAIYO YUDEN X5R JMK212BJ475
 C2: TAIYO YUDEN X5R JMK212BJ475
 D1: PHILIPS PMEG2010
 L1: MURATA LQH32CN-100 OR EQUIVALENT

3460 TA07

Efficiency

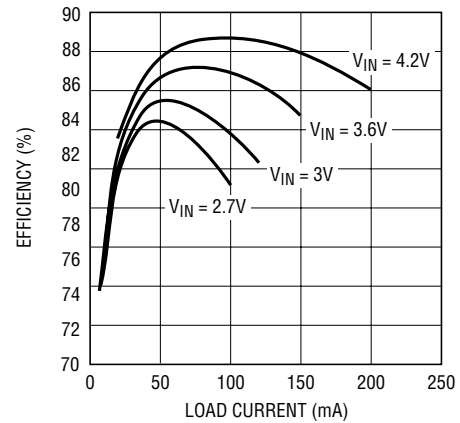

3460 TA07a

TYPICAL APPLICATIONS

12V to 36V Step-Up Converter

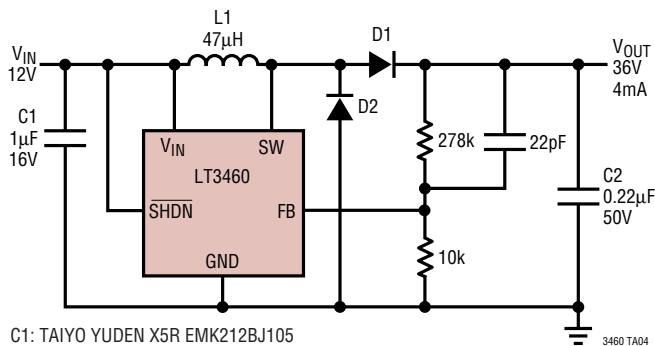

C1: TAIYO YUDEN X5R EMK212BJ105
 C2: TAIYO YUDEN X7R UMK212BJ224
 D1, D2: CENTRAL SEMICONDUCTOR CMOD4448
 L1: TAIYO YUDEN LB2012

3460 TA04

Load Step Response

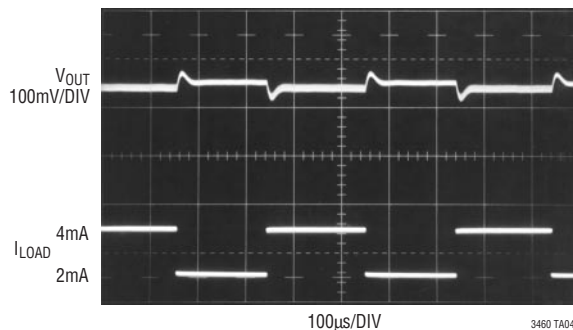

3460 TA04a

5V to 36V Step-Up Converter

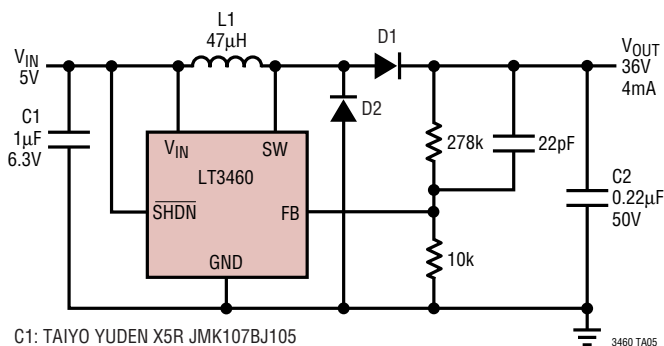

C1: TAIYO YUDEN X5R JMK107BJ105
 C2: TAIYO YUDEN X7R UMK212BJ224
 D1, D2: CENTRAL SEMICONDUCTOR CMOD4448
 L1: TAIYO YUDEN LB2012

3460 TA05

Load Step Response

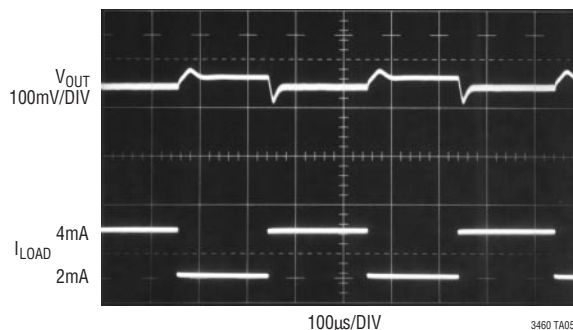

3460 TA05a

PACKAGE DESCRIPTION

S5 Package
5-Lead Plastic TSOT-23
 (Reference LTC DWG # 05-08-1635)

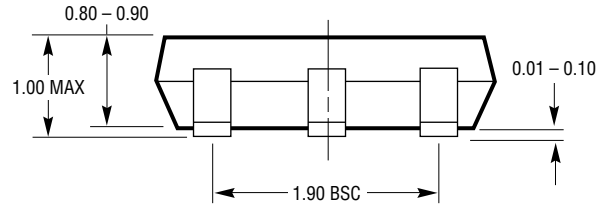
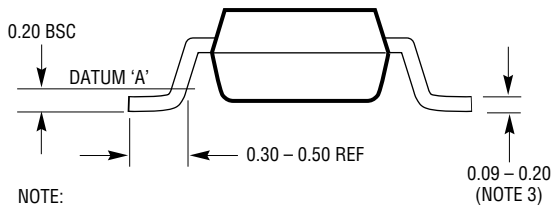
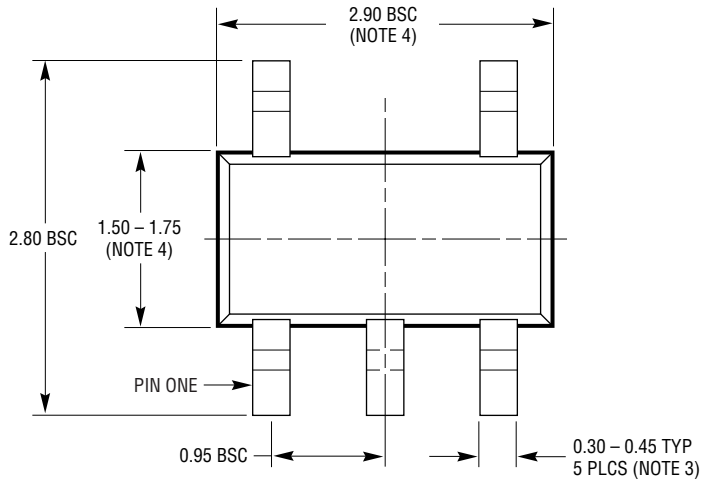
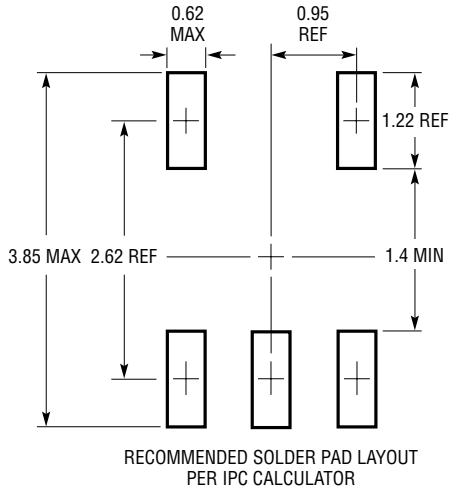

S5 TSOT-23 0302

- NOTE:
1. DIMENSIONS ARE IN MILLIMETERS
 2. DRAWING NOT TO SCALE
 3. DIMENSIONS ARE INCLUSIVE OF PLATING
 4. DIMENSIONS ARE EXCLUSIVE OF MOLD FLASH AND METAL BURR
 5. MOLD FLASH SHALL NOT EXCEED 0.254mm
 6. JEDEC PACKAGE REFERENCE IS MO-193

PACKAGE DESCRIPTION

SC6 Package
6-Lead Plastic SC70
 (Reference LTC DWG # 05-08-1638)

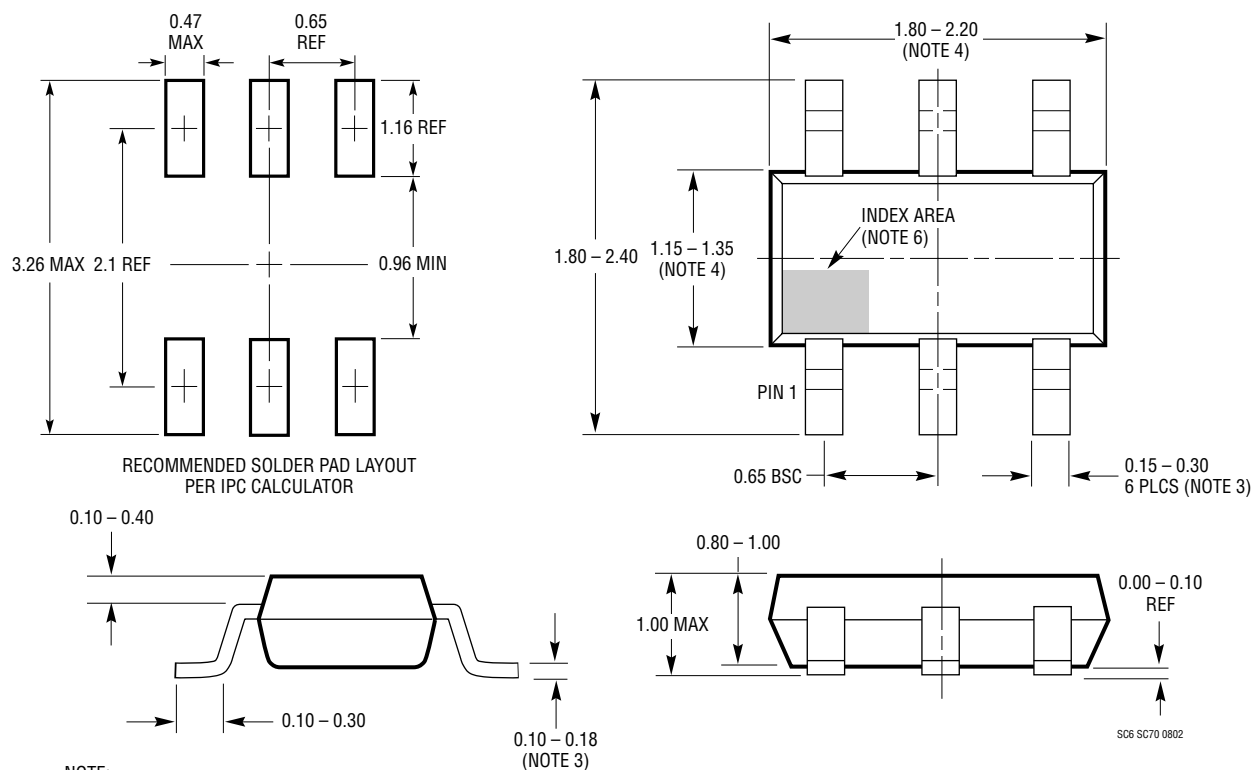

- NOTE:
1. DIMENSIONS ARE IN MILLIMETERS
 2. DRAWING NOT TO SCALE
 3. DIMENSIONS ARE INCLUSIVE OF PLATING
 4. DIMENSIONS ARE EXCLUSIVE OF MOLD FLASH AND METAL BURR
 5. MOLD FLASH SHALL NOT EXCEED 0.254mm
 6. DETAILS OF THE PIN 1 IDENTIFIER ARE OPTIONAL, BUT MUST BE LOCATED WITHIN THE INDEX AREA
 7. EIAJ PACKAGE REFERENCE IS EIAJ SC-70

TYPICAL APPLICATIONS

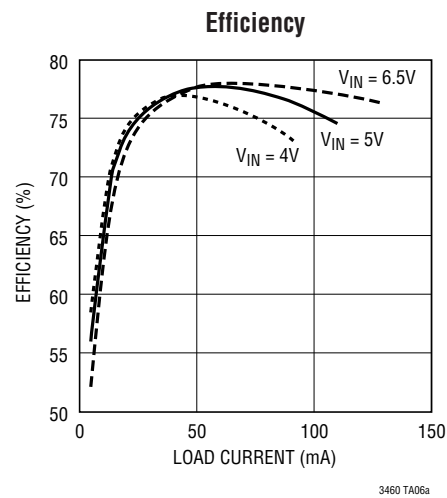
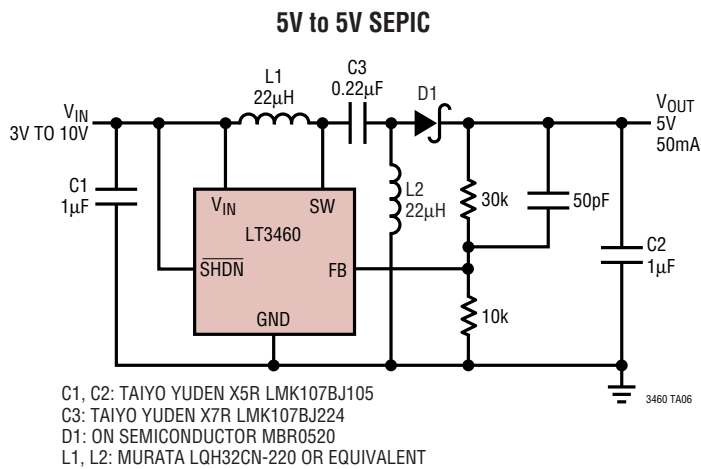

RELATED PARTS

PART NUMBER	DESCRIPTION	COMMENTS
LT1613	550mA (I_{SW}), 1.4MHz, High Efficiency Step-Up DC/DC Converter	V_{IN} : 0.9V to 10V, $V_{OUT(MAX)}$ = 34V, I_Q = 3mA, I_{SD} < 1µA, ThinSOT Package
LT1615/LT1615-1	300mA/80mA (I_{SW}), Constant Off-Time, High Efficiency Step-Up DC/DC Converter	V_{IN} : 1.2V to 15V, $V_{OUT(MAX)}$ = 34V, I_Q = 20µA, I_{SD} < 1µA, ThinSOT Package
LT1944/LT1944-1	Dual Output 350mA/100mA (I_{SW}), Constant Off-Time, High Efficiency Step-Up DC/DC Converter	V_{IN} : 1.2V to 15V, $V_{OUT(MAX)}$ = 34V, I_Q = 20µA, I_{SD} < 1µA, MS Package
LT1945	Dual Output, Pos/Neg, 350mA (I_{SW}), Constant Off-Time, High Efficiency Step-Up DC/DC Converter	V_{IN} : 1.2V to 15V, $V_{OUT(MAX)}$ = ±34V, I_Q = 20µA, I_{SD} < 1µA, MS Package
LT1961	1.5A (I_{SW}), 1.25MHz, High Efficiency Step-Up DC/DC Converter	V_{IN} : 3V to 25V, $V_{OUT(MAX)}$ = 35V, I_Q = 0.9mA, I_{SD} < 6µA, MS8E Package
LTC3400/LTC3400B	600mA (I_{SW}), 1.2MHz, Synchronous Step-Up DC/DC Converter	V_{IN} : 0.85V to 5V, $V_{OUT(MAX)}$ = 5V, I_Q = 19µA/300µA, I_{SD} < 1µA, ThinSOT Package
LTC3401/LTC3402	1A/2A (I_{SW}), 3MHz, Synchronous Step-Up DC/DC Converter	V_{IN} : 0.5V to 5V, $V_{OUT(MAX)}$ = 6V, I_Q = 38µA, I_{SD} < 1µA, MS Package
LT3461/LT3461A	0.3A (I_{SW}), 1.3MHz/3MHz, High Efficiency Step-Up DC/DC Converter with Integrated Schottky	V_{IN} : 2.5V to 16V, $V_{OUT(MAX)}$ = 38V, I_Q = 2.8mA, I_{SD} < 1µA, SC70, ThinSOT Packages
LT3464	0.08A (I_{SW}), High Efficiency Step-Up DC/DC Converter with Integrated Schottky, Output Disconnect	V_{IN} : 2.3V to 10V, $V_{OUT(MAX)}$ = 34V, I_Q = 25µA, I_{SD} < 1µA, ThinSOT Package
LT3465/LT3465A	Constant Current, 1.2MHz/2.7MHz, High Efficiency White LED Boost Regulator with Integrated Schottky Diode	V_{IN} : 2.7V to 16V, $V_{OUT(MAX)}$ = 30V, I_Q = 1.9mA, I_{SD} < 1µA, ThinSOT Package