

**DESCRIPTION**

The LX2202 Linear Battery Charger is a multi-state (2 stage) Li-Ion battery charger (Constant current / Constant voltage) that is designed to minimize battery charge time (even from current limited sources such as USB) and provide a simplified interface to control battery discharge.

LX2202 features up to 2A charging current from an AC adapter and an isolated battery topology to minimize charge time from current limited sources such as USB. A thermal control loop maintains a safe operating temperature at all times.

The LX2202 provides a seamless complete battery interface. When the input power source is removed, the LX2202 provides the discharge path for the battery with extremely low discharge impedance. This eliminates the need for external discharge switch and voltage supervisors.

In USB mode, the LX2202 provides three levels of current limit: 100mA, 500mA, and off.

The LX2202 (compared to the LX2201) has improved charge and discharge mode detection circuitry. A UVLO feature prevents battery charging when VDD is less than 3.6V.

The LX2202 uses three resistors to program the constant charge current level, for setting the termination charge current, and for varying the USB charge current limits. LX2202 support two types of Li-Ion battery chemistry; 4.1V and 4.2V through logical input (VM pin). The LX2202 provides a charging status indicator.

The LX2202 features a pre-charge conditioning mode for batteries that have been deeply discharged and also has a top off charge mode for batteries that are left on the charger for extended periods.

The LX2202 is available in a high power 4mm x 4mm, 20-pin MLP, surface mount package.

**KEY FEATURES**

- Up to 2A Charge Current
- Internal Pass Element Can Function as a Reverse Direction Load Switch
- USB Compliant Charging States using optional USB input
- Isolated Battery Topology
- Low R<sub>DS(ON)</sub> in Discharge Mode
- Full Capacity Charging
- True Charge Indicator
- Wall Supply Regulator Tolerance 5V + 10%
- Topping Charge with Voltage Monitoring Mode
- Improved charge/discharge mode detection circuitry
- Small, High Power 20-lead MLP package
- Selectable Li-Ion Battery for 4.1V or 4.2V Applications

**APPLICATIONS**

- Batteries up to 4AH Ratings (C/2)
- Cell Phones
- PDAs
- Charging Cradles
- Digital Cameras
- Low Cost Single Li-Ion Cell Chargers

**IMPORTANT:** For the most current data, consult MICROSEMI's website: <http://www.microsemi.com>

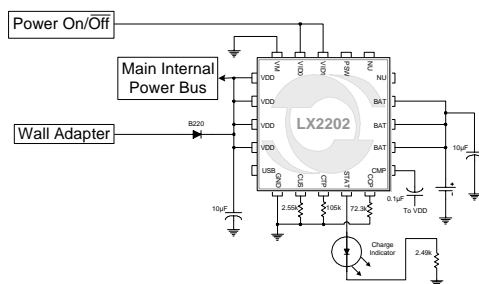
**PRODUCT HIGHLIGHT**

**State Select Truth Table**

VID0	VID1	VDD > V <sub>BAT</sub>	V <sub>BAT</sub> > VDD
0	0	Switch open – charging disabled.	Switch open – discharge disabled.
0	1	Charging – USB high level if using USB.	Switch open – discharge disabled.
1	0	Charging – USB low level if using USB.	Battery Discharging. MOSFET fully enhanced with current flow V <sub>BAT</sub> to VDD.
1	1	Charging – USB high level if using USB.	Battery Discharging. MOSFET fully enhanced with current flow V <sub>BAT</sub> to VDD.

**PACKAGE ORDER INFO**

T <sub>A</sub> (°C)	<b>LQ</b>	<b>Plastic MLP 4x4mm 20-Pin</b>
	RoHS Compliant / Pb-free	
-40 to 125	LX2202CLQ	

Note: Available in Tape & Reel.  
Append the letters "TR" to the part number.  
(i.e. LX2202CLQ-TR)

**ABSOLUTE MAXIMUM RATINGS**

Supply Voltage (V <sub>USB</sub> or V <sub>VDD</sub> )	-0.3V to 7V
Analog Input Signals (VID <sub>x</sub> , VM, SNS)	-0.3V to 7V
Battery Charging Current (I <sub>BAT</sub> )	2A
Discharge Current (I <sub>VDD</sub> )	3A
Operating Junction Temperature	150°C
Storage Temperature Range	-65°C to 150°C
USB Maximum DC Current	500mA
USB Maximum Surge Current	2A
RoHS / Pb-free Peak Package Solder Reflow Temperature (40 second maximum exposure)	260°C(+0, -5)

Note: Exceeding these ratings could cause damage to the device. All voltages are with respect to Ground. Currents are positive into, negative out of specified terminal.

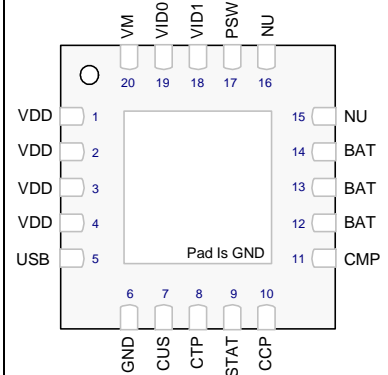
**PACKAGE PIN OUT**

**LQ PACKAGE**  
(Top View)

RoHS / Pb-free 100% Matte Tin Lead Finish

**THERMAL DATA**
**LQ Plastic Micro Lead Frame Quad Package 20-Pin**

**THERMAL RESISTANCE-JUNCTION TO AMBIENT,  $\theta_{JA}$**

**40°C/W**

Junction Temperature Calculation:  $T_J = T_A + (P_D \times \theta_{JA})$ .

The  $\theta_{JA}$  numbers are guidelines for the thermal performance of the device/pc-board system. All of the above assume no ambient airflow.

**FUNCTIONAL PIN DESCRIPTION**

Name	Description
BAT	Charging Output - This pin is wired to the positive terminal of the battery. (The negative battery terminal is wired to GND.)
CCP	Charge Current Programming Pin - A resistor (RCP) is connected between this pin and GND. The constant current is determined by the following relationship: $I_{BAT(MAX)} = \frac{73200}{R_{CCP}}$
CMP	Compensation Pin - Connect a 0.1 $\mu$ F compensation capacitor from this pin to VDD.
CTP	Charge Termination Programming Pin - A resistor (RTP) is connected between this pin and GND. The termination charge current is determined by the following relationship: $I_{BAT(MIN)} = \frac{5250}{R_{CTP}}$
CUS	Maximum USB Current Programming Pin - A resistor (RUS) is connected between this pin and GND. The Hi Level charge current is determined by the following relationship: $I_{USB(HIGH)} = \frac{1211}{R_{USB}}$
GND	Common Ground
NU	This pin is floating and will not affect performance.
PSW	PMOS Switch driver - This output is designed to drive the gate of an external PMOS power switch. The driver is pulled low (PMOS on state) when $V_{DD} > V_{BAT}$ .
VDD	Common Power Node - Connects to system power bus.
VID <sub>x</sub>	State Select Input - Applying a two bit TTL compatible signal sets the desired state of the charger corresponding to the Truth Table.
USB	Voltage Input - Current limited USB input. Apply a USB compliant power input.
VM	Voltage Mode Select - Selects the constant voltage charge level. Wired to USB for 4.1V and GND for 4.2V.
STAT	Status - This pin is a logic high level when the battery is being charged. A low signal indicates either under voltage lockout, charge completed, or $V_{BAT} > V_{DD}$ , or $VID_0 = VID_1 = 0$ .

**ELECTRICAL CHARACTERISTICS**

Unless otherwise specified, the following specifications apply over the ambient temperature  $0^{\circ}\text{C} \leq T_A \leq 70^{\circ}\text{C}$  except where otherwise noted and the following test conditions:  $V_{DD} = 5.0\text{V}$ ,  $V_M = \text{GND}$ ,  $V_{ID0} = V_{ID1} = V_{BAT}$ ,  $R_{CCP} = 72.3\text{k}$ ,  $R_{CTP} = 105\text{k}$ ,  $R_{USB} = 2.55\text{k}$ .

Parameter	Symbol	Test Conditions	LX2202			Units
			Min	Typ	Max	
<b>MAIN CIRCUITRY</b>						
Input Voltage	$V_{DD}$		4.5		6	V
USB Input voltage	$V_{USB}$		4.35		6	V
Under Voltage Charging Lockout	$V_{DDUVLO}$	$V_{BAT} = 0$ ; Rising $V_{DD}$		3.60	3.85	V
Quiescent Current	$I_{GND}$	$V_{DD} > V_{BAT}$		2.1	4	mA
		$V_{DD} < V_{BAT}$		20	40	$\mu\text{A}$
		$V_{DD} < V_{BAT}$ , $V_{ID0} = V_{ID1} = 0\text{V}$		9	15	$\mu\text{A}$
CTP Bias Voltage	$V_{CTP}$	$I_{BAT} > 100\text{mA}$		1.26		V
CCP Bias Voltage	$V_{CCP}$			1.26		V
CUS Bias Voltage	$V_{CUS}$			2.6		V
<b>CONSTANT VOLTAGE MODE</b>						
Constant Voltage Charge Voltage	$V_{CVL}$	$V_M = \text{Lo}$ ; $-40\text{C}$ to $125\text{C}$	4.16	4.2	4.24	V
		$V_M = \text{Hi}$ ; $-40$ to $125\text{C}$	4.06	4.1	4.14	
Top Off Charge Droop Threshold	$V_{DRP}$		96	97	98	$\% V_{BAT} / V_{CVL}$
<b>CONSTANT CURRENT MODE</b>						
BAT Constant Current Accuracy	$I_{CCL}$		0.85	1	1.15	A
Conditioning Current	$I_{COND}$	$V_{BAT} < V_{CTV}$ ; @ $25^{\circ}\text{C}$	3.0	4.6	6.0	$\% I_{BAT} / I_{CCL}$
Conditioning Current Mode Threshold Voltage	$V_{CTV}$			2.8		V
Charge Termination Current Accuracy	$I_{BAT}$	@ $25^{\circ}\text{C}$	35	50	65	mA
<b>USB CURRENT LIMIT</b>						
USB Low Current Limit	$I_{IN}$	$V_{USB} = 5\text{V}$ , $V_{DD} < V_{USB}$ , $V_{ID1} = \text{Lo}$	85	93	100	mA
USB High Current Limit	$I_{IN}$	$V_{USB} = 5\text{V}$ , $V_{DD} < V_{USB}$ , $V_{ID1} = \text{Hi}$	425	463	500	mA
<b>LOGIC</b>						
STAT Logic High Output	$V_{STAT}$	$V_{USB} = 5.0\text{V}$ , $I_{STAT} = -5\text{mA}$		4.5	5	V
STAT Logic Low Output	$V_{STAT}$	$V_{USB} = 5.0\text{V}$ , $I_{STAT} = 25\mu\text{A}$			0.4	V
State Select Threshold	$V_{VID}$	Logic Hi	2.0			V
		Logic Lo			0.8	
VM Select Threshold	$V_{VM}$	Logic Hi	2.0			V
		Logic Lo			0.8	
<b>THERMAL SHUTDOWN</b>						
Maximum Junction Temperature	$T_J$	$V_{USB} = 5.0\text{V}$ , $I_{OUT} = 1\text{A}$ , Temperature Rising	130	140	150	$^{\circ}\text{C}$
<b>BI-DIRECTIONAL PASS ELEMENT CONTROL</b>						
Discharge Switch On Resistance	$R_{DS(ON)}$	$I_{BAT} = -1\text{A}$ (Not Tested)		130	150	m $\Omega$
Charging Threshold	$V_{CHG}$	$V_{USB} > V_{BAT} + V_{CHG}$		40		mV
Discharging Threshold	$V_{DCH}$	$V_{USB} < V_{BAT} + V_{DCH}$		60		mV
Pass Element Switch Mode Delay	tsw	Charge-to-discharge or Discharge-to-charge		5	10	$\mu\text{s}$
<b>PSW FET DRIVER</b>						
High Output Voltage	$V_{PSW}$	$V_{USB} < V_{BAT}$ , $I_{PSW} = 0$ , $V_{BAT} = 4.2\text{V}$	4.1	4.2		V
Low Output Voltage	$V_{PSW}$	$V_{USB} > V_{BAT}$ , $I_{PSW} = 0$		0	0.2	V
ORing Resistance	$R_{PSW}$		5	10	15	K $\Omega$
Switch Delay (after tsw)	$t_{PSW}$	$C_{PSW} = 1000\text{pF}$ , to $V_{PSW} = (V_{BAT} - 1\text{V})$	0	500	1000	Ns
<b>HEAD ROOM</b>						
Charging headroom		$V_{DD} - V_{BAT}$ , $I_{BATT} = 5\text{mA}$ ; not tested in production		65		mV
Discharging headroom		$V_{BAT} - V_{DD}$ , $I_{BATT} = -20\text{mA}$ ; not tested in production		65		mV

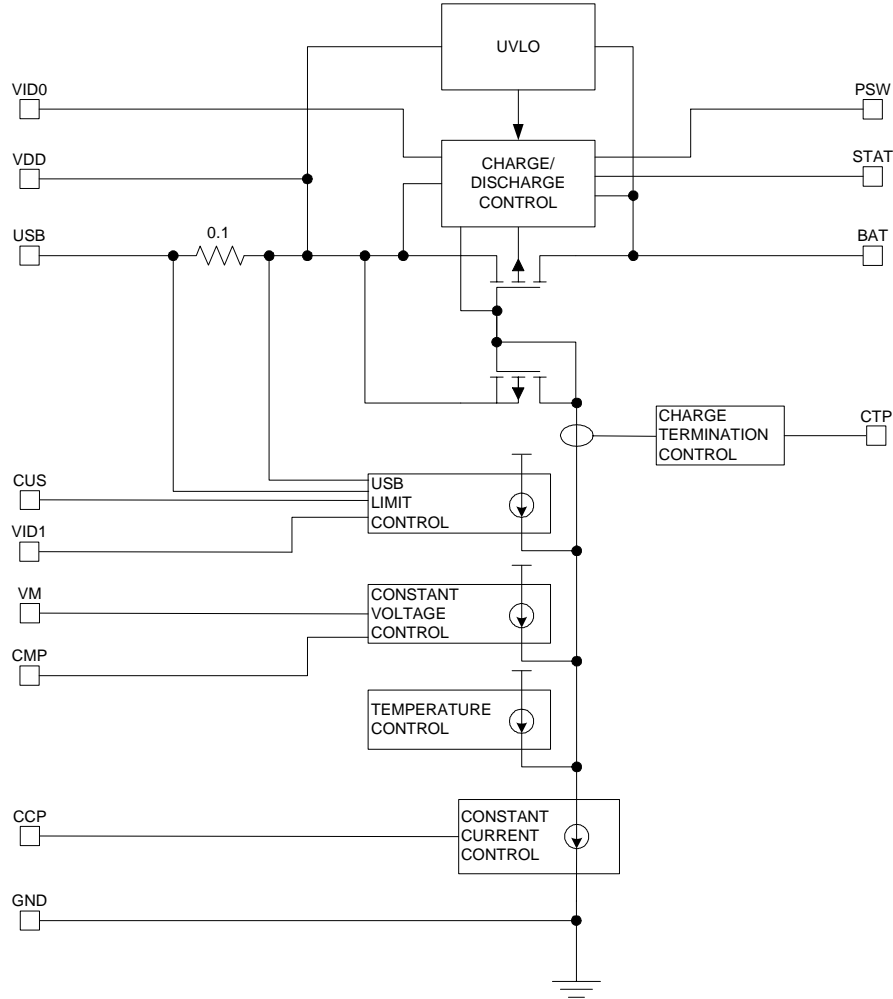
**SIMPLIFIED BLOCK DIAGRAM**

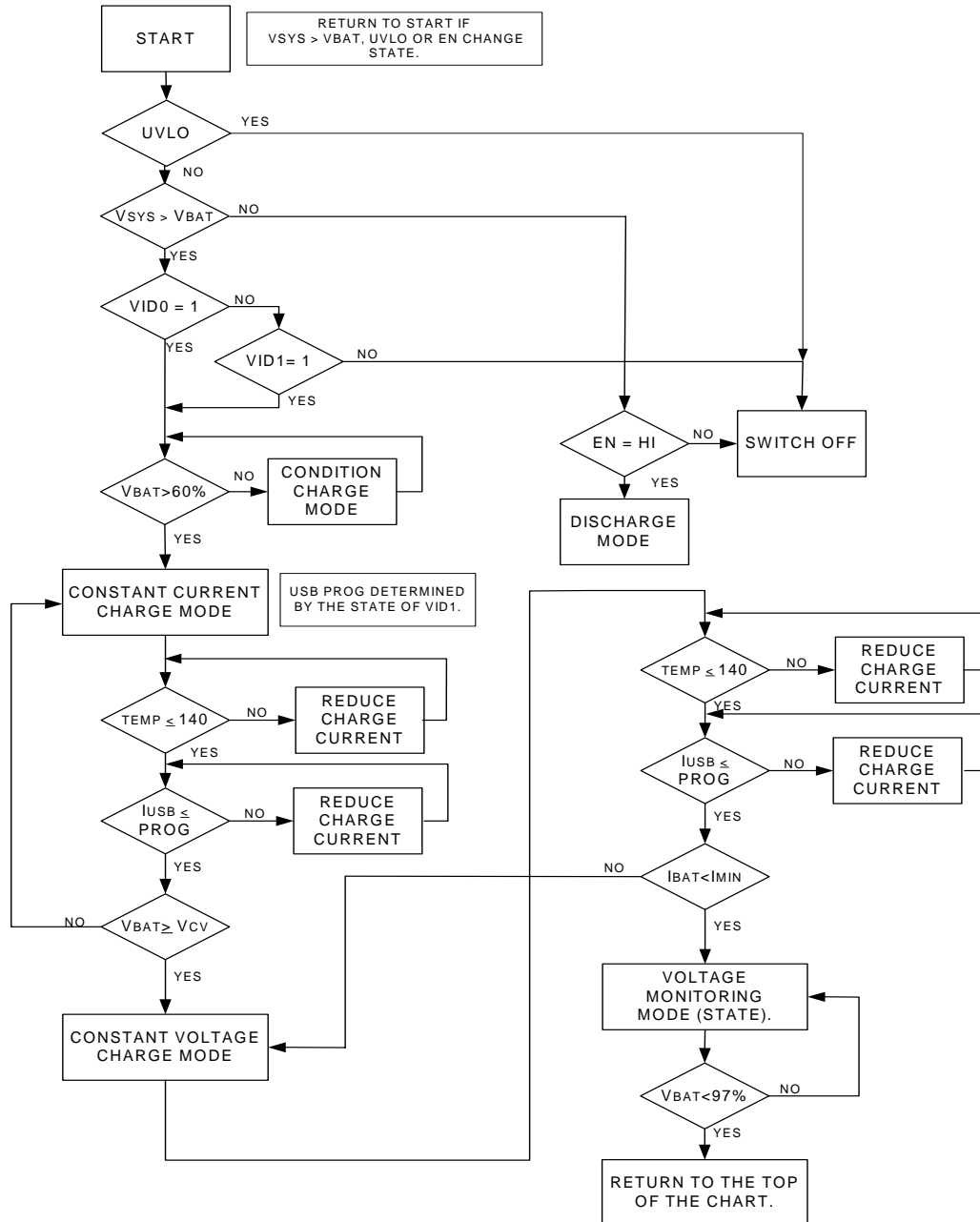
**Figure 1 – Simplified Block Diagram**

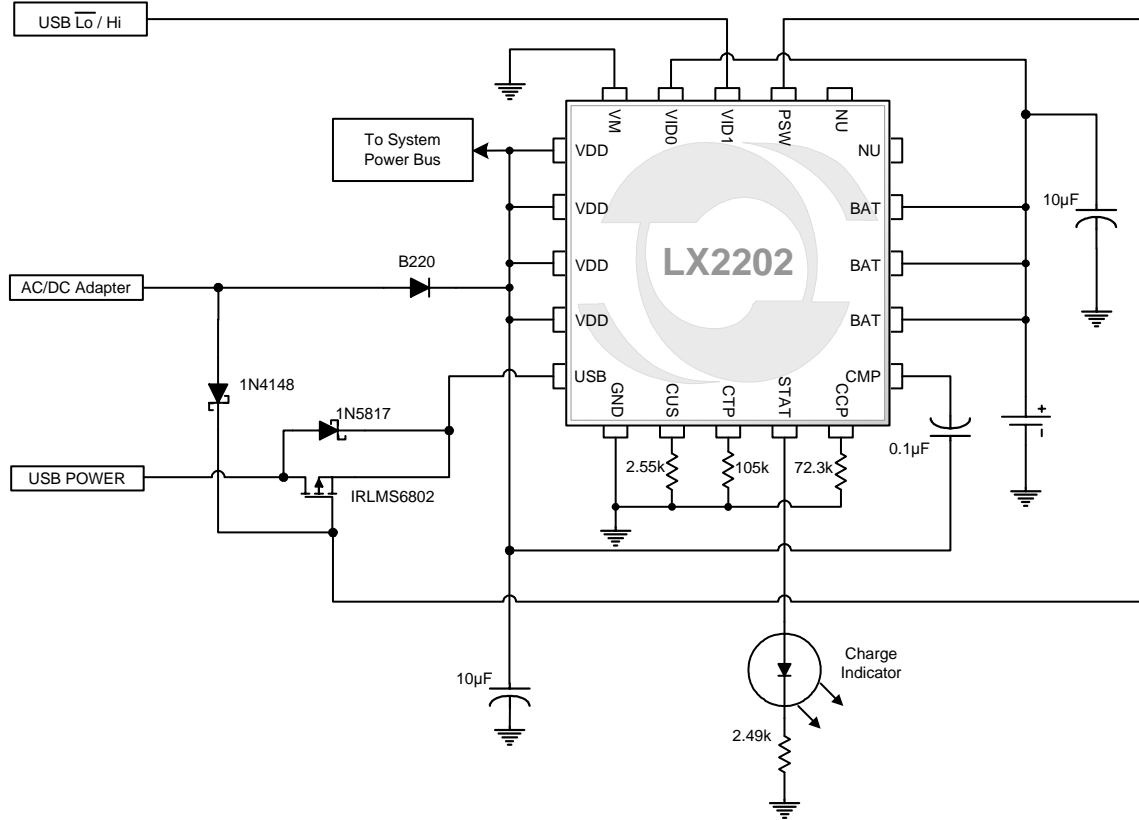
**APPLICATION CIRCUITS**
**LX2202 CONTROL FLOW DIAGRAM**

**Figure 2 – Control Flow Diagram**

**APPLICATION SCHEMATICS**

**State Select Truth Table**

VID0	VID1	VDD > V <sub>BAT</sub>	V <sub>BAT</sub> > VDD
0	0	Switch open – charging disabled.	Switch open – discharge disabled.
0	1	Charging – USB high level if using USB.	Switch open – discharge disabled.
1	0	Charging – USB low level if using USB.	Battery Discharging. MOSFET fully enhanced with current flow V <sub>BAT</sub> to VDD.
1	1	Charging – USB high level if using USB.	Battery Discharging. MOSFET fully enhanced with current flow V <sub>BAT</sub> to VDD.

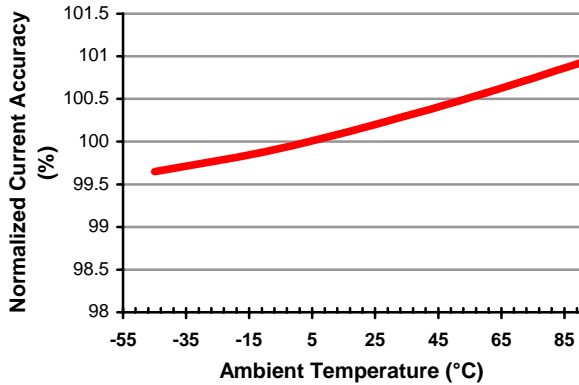
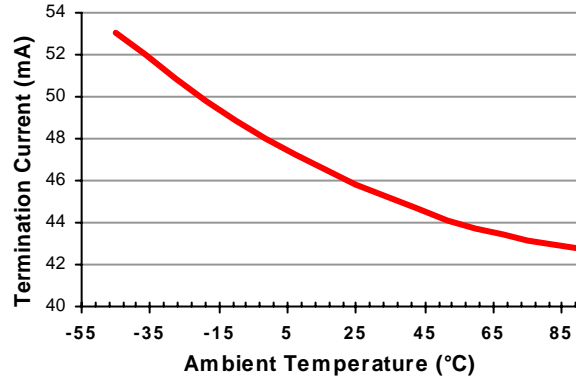
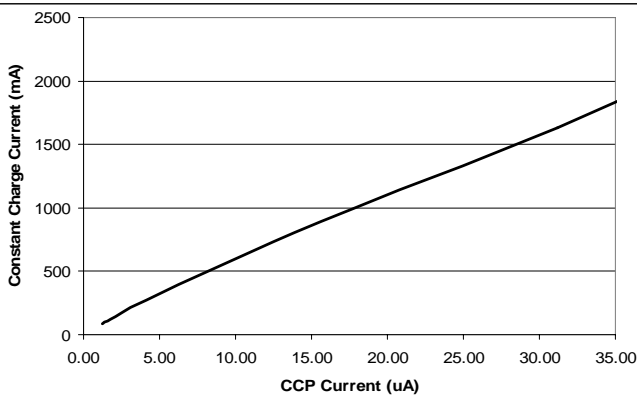
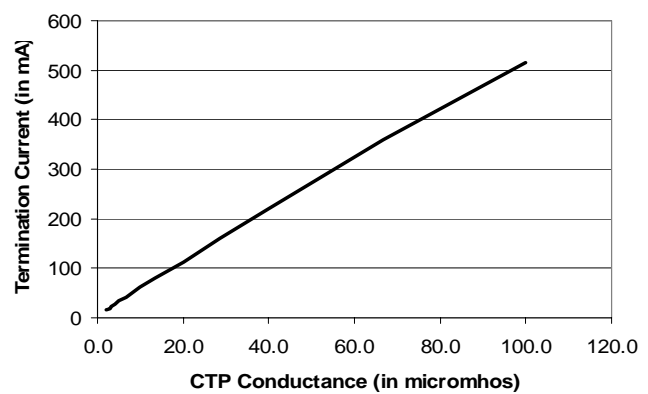
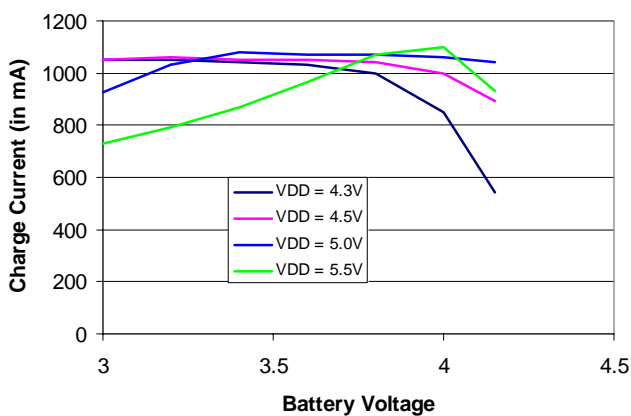
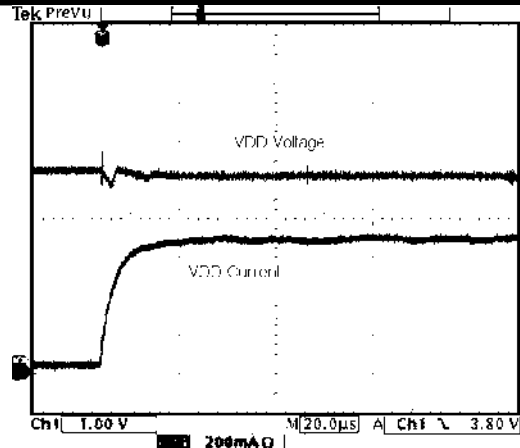
**Figure 3 – AC Adapter and USB Supply (Charge and Discharge Modes)**

(1N4148 and IRLMS6802 are optional to lower USB voltage drop.)

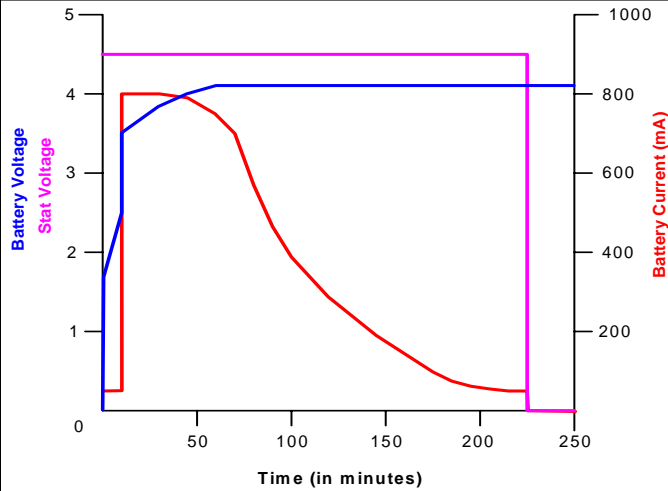
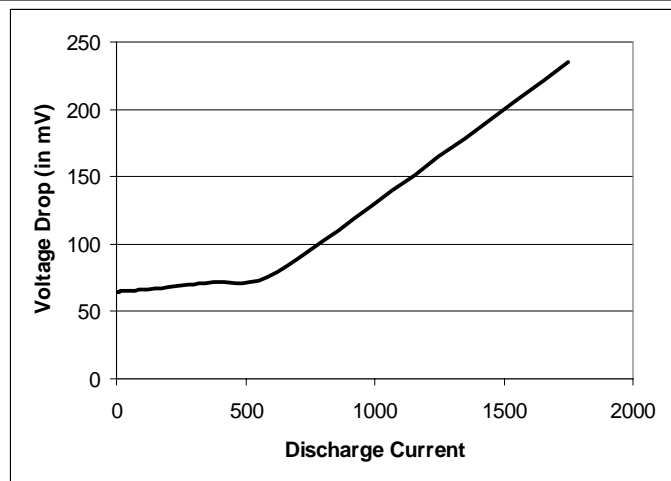
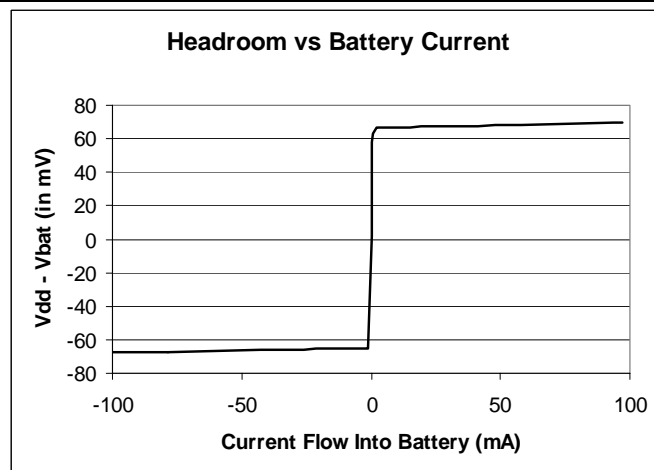
**CHARGING CURRENT ACCURACY OVER TEMP**

**TERMINATION CURRENT OVER TEMP**

**CONSTANT CURRENT PROGRAMMING**

**TERMINATION CURRENT VS CTP CONDUCTANCE**

**CHARGING CURRENT OVER VDD VOLTAGE**

**DISCHARGE MODE DYNAMIC RESPONSE**

**CHARGING PROFILE**

**DISCHARGE VOLTAGE DROP**

**HEADROOM CONTROL**



**THEORY OF OPERATION****GENERAL DESCRIPTION**

The LX2202 is designed to charge a single cell Lithium Ion battery using two steps: a constant current step followed by a constant voltage step. The basic charger function uses the VDD pins as an input and BAT pins as the output. The LX2202 charger has a programmable maximum current (programmable by the resistor value between pin CCP to GND) which is the maximum charging current during the Constant Current Mode of the charging profile. The low dropout of the pass element allows the battery to be charged from a loosely regulated power supply. In the Constant Voltage Mode, the battery terminal voltage can be regulated to 4.1V or 4.2V by strapping the VM pin to VDD or GND, respectively. The charger will terminate constant voltage charging once the current drops below the minimum current setting (programmable by the resistor value between pin CTP to GND).

The LX2202 has an integrated thermostat with a linear thermal regulation loop that will throttle back the charging current to prevent the internal die temperature from exceeding 150°C. This feature prevents damage to the system board when the IC exceeds its thermal temperature.

**CURRENT CHARGE MODE**

A conditioning current is applied to batteries that are deeply discharged and have a terminal voltage less than 60% of the constant voltage level. The conditioning current is 5% of the CCP programmable constant current level (except where it might be limited in the USB states). Once the battery terminal voltage exceeds the 60% level, the full constant current level is applied (unless charging current is limited by one of the other charger control loops).

**CHARGE TERMINATION MODE**

To increase system battery life and avoid float charging, the LX2202 turns off the pass element once the battery has been fully charged. The charge termination state occurs at the end of constant voltage mode. The charge status changes state when charging is completed.

**TOP OFF CHARGE MODE**

Once the charger has completed a charge cycle, if power remains applied, the LX2202 enters a Voltage Monitoring mode. In this mode the LX2202 monitors the battery terminal voltage and applies a top off charge if the battery voltage drops by more than 3% of full scale. This feature is especially important for charging systems in equipment where usage is infrequent.

**USB CHARGE MODE**

The LX2202 is fully compliant with, and supports, the USB specifications – the Low Power Peripheral (100mA) and High Power Peripherals (500mA). VID1 logic input selects USB charge currents. The LX2202 senses the current flowing from the USB terminal to the VDD terminal; then it limits the USB current by reducing the current flowing from  $V_{DD}$  to  $V_{BAT}$ .

**DISCHARGE MODE**

VID0 is used to enable discharge mode enable. The system load is connected to VDD. The input power is connected to VDD through an external diode. When the input power is removed, the battery current flows from  $V_{BAT}$  to VDD. The circuit of Figure 3 shows the LX2202 in a discharge mode configuration with both AC adapter and USB inputs. The USB input is diode ORed to the VDD pin and uses a MOSFET to reduce the diode drop across the ORing diode. The LX2202 provides a signal “PSW” to control the MOSFET for charge and discharge modes. When both AC and USB power are applied the PSW signal is overridden by the AC adapter diode and the MOSFET is turned off.

**UNDER VOLTAGE LOCK OUT**

The LX2202 has an under voltage lock-out feature that monitors the VDD terminal and prevents the battery charger from entering charge mode if the VDD terminal is less than 3.6V (nominal).

**APPLICATION NOTE****REDUCED USB CHARGE TIME**

The LX2202 has an isolated battery topology which reduces charge time from USB when the appliance is turned on while also charging. Because the system power rail can be a higher voltage than the battery voltage, the system will require less power from the USB source which leaves more power available to charge the battery which charges the battery faster. For example, if the system draws 1W, and the USB input is 5V, the system draws  $1W/5V = 200mA$  from the USB source; this leaves 300mA to charge the battery. In a topology where the load connects directly to the battery (as is done with conventional linear chargers), if the average battery voltage is 3.7V, the system will draw  $1W/3.7V = 270mA$  from the USB source, this leaves only 230mA to charge the battery. In this case the LX2202 will charge the battery 30% faster.

**CURRENT LIMITED POWER SUPPLIES**

The LX2202 has special headroom voltage regulation circuitry that allows charging from current limited power sources. The LX2202 increases the impedance of the pass element under small charge or discharge currents so that mode change situations can be more readily detected by the internal circuits. This improved mode discrimination allows the battery to aid the current limited input power supply when the system load demands it and to switch back to charge mode when the system power demand is reduced.

**USB COMPLIANCE**

To be compliant with the USB specification, the +5V current must be less than 100mA in the low power mode and less than 500mA in the high power mode. If the LX2202 is configured as shown in Figure 3, it is possible for the system to consume more than the maximum allowed USB current (in which case the battery charging current will have been fully scaled back). If it is not possible to regulate the load current when charging from a USB power source and strict adherence to the USB power budget is required, in this case the system load can be applied directly across the battery and the LX2202 will prevent the combination of the load plus battery from drawing more power than is allowed for USB compliance.

**LAYOUT GUIDELINES**

- It is important when laying out the LX2202 to place 10 $\mu$ F ceramic capacitors close to the VDD and V<sub>BAT</sub> IC terminals to filter switching transients.
- It is important to provide a low thermal impedance path from the thermal pad on the bottom of the LX2202 package to the ground plane of the circuit board to maximize the heat dissipation.

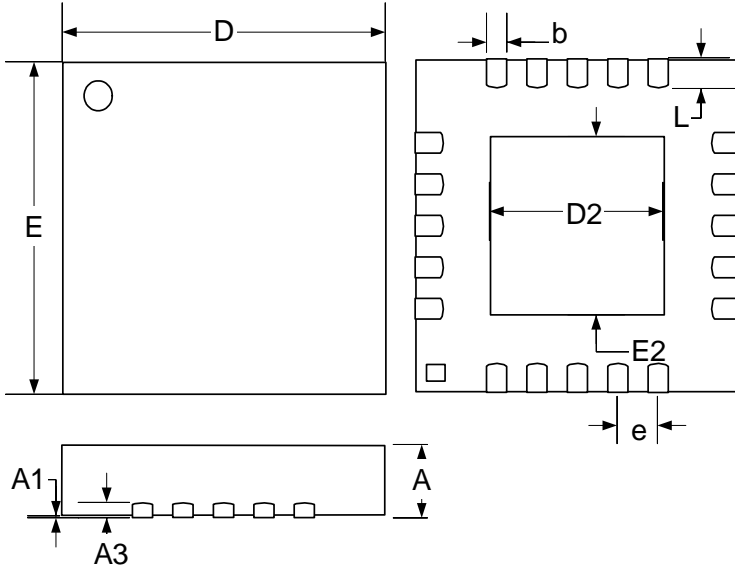
**PACKAGE DIMENSIONS**
**LQ** 20-Pin MLPQ Plastic 4x4mm (114x114DAP)

Dim	MILLIMETERS		INCHES	
	MIN	MAX	MIN	MAX
A	0.80	1.00	0.031	0.039
A1	0.00	0.05	0.000	0.002
A3	0.20	REF	0.008	REF
b	0.18	0.30	0.007	0.088
D	4.00	BSC	0.157	BSC
D2	2.59	2.79	0.102	0.110
E	4.00	BSC	0.157	BSC
E2	2.59	2.79	0.102	0.110
e	0.50	BSC	0.019	BSC
L	0.30	0.50	0.011	0.019



**Microsemi**<sup>®</sup>

**LX2202**

**2A Li-Ion Linear Charger and Power Control**

**PRODUCTION DATA SHEET**

**NOTES**

PRODUCTION DATA – Information contained in this document is proprietary to Microsemi and is current as of publication date. This document may not be modified in any way without the express written consent of Microsemi. Product processing does not necessarily include testing of all parameters. Microsemi reserves the right to change the configuration and performance of the product and to discontinue product at any time.