



#### REVISION HISTORY

<u>Revision</u>	<u>Description</u>	<u>Issue Date</u>
Rev. 1.0	Initial Issue	Jul.25.2004
Rev. 1.1	Adding PKG type : 32 P-DIP	May.14.2007
	Revised Test Condition of I <sub>SB1</sub> /I <sub>DR</sub>	
Rev. 1.2	Deleted L Spec. Added SL Spec. Revised V <sub>TERM</sub> to V <sub>T1</sub> and V <sub>T2</sub> Revised Test Condition of I <sub>CC</sub>	Nov.8.2007
Rev. 1.3	Revised I <sub>SB</sub> /I <sub>DR</sub>	Mar.21.2008
Rev. 1.4	Adding PKG type : 44 TSOP-II	Jul.14.2008
Rev. 1.5	Added I <sub>SB1</sub> /I <sub>DR</sub> values when T <sub>A</sub> = 25°C and T <sub>A</sub> = 40°C	Mar.30.2009
	Revised <b><u>FEATURES &amp; ORDERING INFORMATION</u></b> <b><u>Lead free and green package available to Green package available</u></b> Added packing type in <b><u>ORDERING INFORMATION</u></b> Deleted T <sub>SOLDER</sub> in <b><u>ABSOLUTE MAXIMUM RATINGS</u></b>	
Rev. 1.6	Added PKG type : 32 TSOP-II	Jun.22.2009
Rev. 1.7	Deleted PKG type : 32 TSOP-II	Jul.17.2009
Rev. 1.8	Revised <b><u>PACKAGE OUTLINE DIMENSION</u></b> in page 10/11/12/13	May.7.2010
Rev. 1.9	Revised <b><u>ORDERING INFORMATION</u></b> in page 15 Revised <b><u>PACKAGE OUTLINE DIMENSION</u></b> in page 9	Aug.30.2010
Rev. 1.10	Added PKG type : 32 TSOP-II	Nov.1.2010
Rev. 1.11	Revised <b><u>ORDERING INFORMATION</u></b> in page 16	Mar.9.2011
Rev. 1.12	Deleted PKG type : 44 TSOP-II	Feb.21.2012
Rev. 1.13	Revised <b><u>TEST CONDITION</u></b> of I <sub>CC</sub> /I <sub>CC1</sub> /I <sub>SB1</sub> in <b><u>DC ELECTRICAL CHARACTERISTICS</u></b> (page4) and I <sub>DR</sub> in <b><u>DATA RETENTION CHARACTERISTICS</u></b> (page8) <b><u>PIN CONFIGURATION</u></b> (Page2) <b><u>ORDERING INFORMATION</u></b> (Page15)	Jun.2.2015
Rev. 1.14	Deleted <b><u>WRITE CYCLE</u></b> Notes : 1. WE#,CE# must be high during all address transitions. in page 7 Revised <b><u>ORDERING INFORMATION</u></b> in page 16	Jun.29.2016





### PIN CONFIGURATION

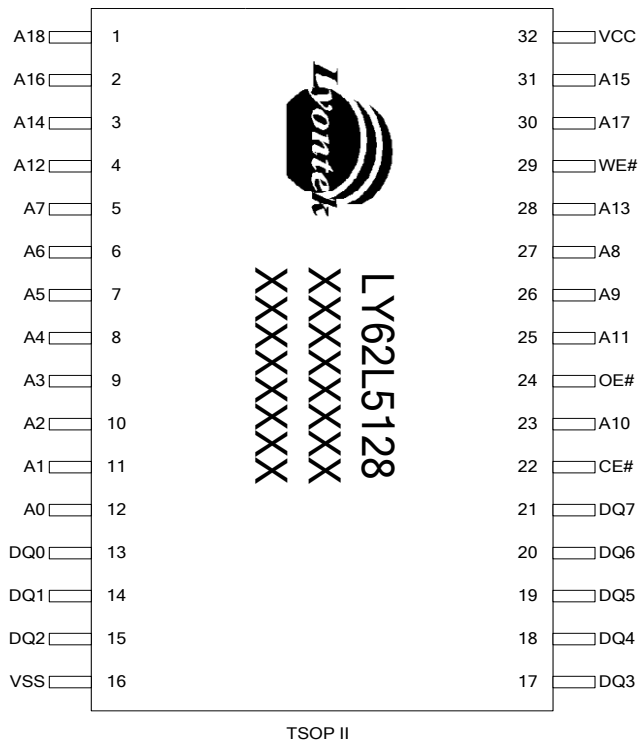
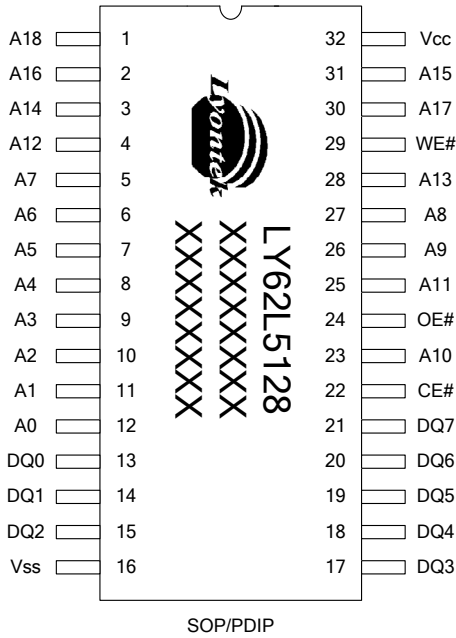



### PIN CONFIGURATION

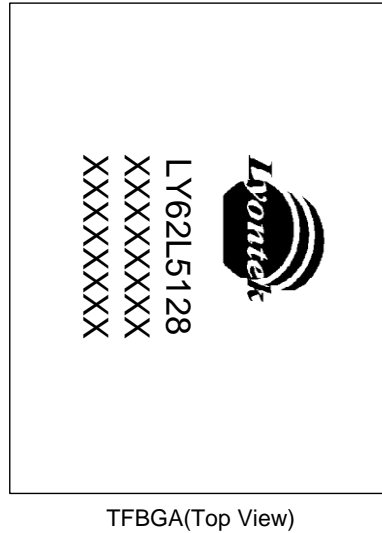
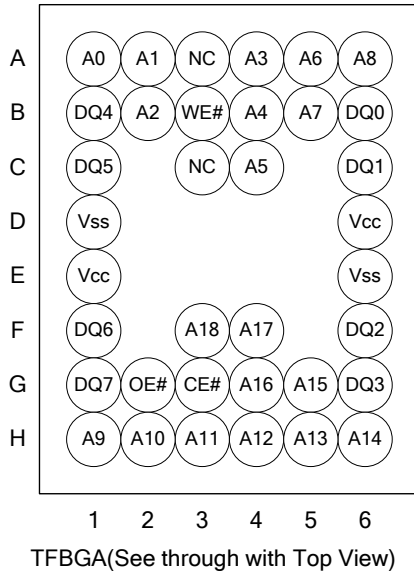

### ABSOLUTE MAXIMUM RATINGS\*

PARAMETER	SYMBOL	RATING	UNIT
Voltage on V <sub>CC</sub> relative to V <sub>SS</sub>	V <sub>T1</sub>	-0.5 to 4.6	V
Voltage on any other pin relative to V <sub>SS</sub>	V <sub>T2</sub>	-0.5 to V <sub>CC</sub> +0.5	V
Operating Temperature	T <sub>A</sub>	0 to 70(C grade)	°C
		-20 to 80(E grade)	
		-40 to 85(I grade)	
Storage Temperature	T <sub>STG</sub>	-65 to 150	°C
Power Dissipation	P <sub>D</sub>	1	W
DC Output Current	I <sub>OUT</sub>	50	mA

\*Stresses greater than those listed under "Absolute Maximum Ratings" may cause permanent damage to the device. This is a stress rating only and functional operation of the device or any other conditions above those indicated in the operational sections of this specification is not implied. Exposure to the absolute maximum rating conditions for extended period may affect device reliability.

### TRUTH TABLE

MODE	CE#	OE#	WE#	I/O OPERATION	SUPPLY CURRENT
Standby	H	X	X	High-Z	I <sub>SB</sub> , I <sub>SB1</sub>
Output Disable	L	H	H	High-Z	I <sub>CC</sub> , I <sub>CC1</sub>
Read	L	L	H	D <sub>OUT</sub>	I <sub>CC</sub> , I <sub>CC1</sub>
Write	L	X	L	D <sub>IN</sub>	I <sub>CC</sub> , I <sub>CC1</sub>

Note: H = V<sub>IH</sub>, L = V<sub>IL</sub>, X = Don't care.



#### DC ELECTRICAL CHARACTERISTICS

PARAMETER	SYMBOL	TEST CONDITION	MIN.	TYP. <sup>*4</sup>	MAX.	UNIT		
Supply Voltage	V <sub>CC</sub>		2.7	3.0	3.6	V		
Input High Voltage	V <sub>IH</sub> <sup>*1</sup>		2.2	-	V <sub>CC</sub> +0.3	V		
Input Low Voltage	V <sub>IL</sub> <sup>*2</sup>		- 0.2	-	0.6	V		
Input Leakage Current	I <sub>LI</sub>	V <sub>CC</sub> ≥ V <sub>IN</sub> ≥ V <sub>SS</sub>	- 1	-	1	μA		
Output Leakage Current	I <sub>LO</sub>	V <sub>CC</sub> ≥ V <sub>OUT</sub> ≥ V <sub>SS</sub> , Output Disabled	- 1	-	1	μA		
Output High Voltage	V <sub>OH</sub>	I <sub>OH</sub> = -1mA	2.2	2.7	-	V		
Output Low Voltage	V <sub>OL</sub>	I <sub>OL</sub> = 2mA	-	-	0.4	V		
Average Operating Power supply Current	I <sub>CC</sub>	Cycle time = Min. CE# = V <sub>IL</sub> , I <sub>I/O</sub> = 0mA Other pins at V <sub>IL</sub> or V <sub>IH</sub>	- 45	-	40	50	mA	
			- 55	-	30	40	mA	
			- 70	-	20	30	mA	
	I <sub>CC1</sub>	Cycle time = 1μs CE# ≤ 0.2V, I <sub>I/O</sub> = 0mA Other pins at 0.2V or V <sub>CC</sub> -0.2V	-	4	5	mA		
Standby Power Supply Current	I <sub>SB</sub>	CE# = V <sub>IH</sub> , other pins at V <sub>IL</sub> or V <sub>IH</sub>	-	0.3	1.25	mA		
	I <sub>SB1</sub>	CE# ≥ V <sub>CC</sub> -0.2V Others at 0.2V or V <sub>CC</sub> - 0.2V	LL	-	2	15	μA	
			LLE/LLI	-	2	20	μA	
			SL <sup>*5</sup>	25°C	-	1	3	μA
			SLE <sup>*5</sup>	40°C	-	1	3	μA
			SLI <sup>*5</sup>		-	1	3	μA
SL	-	1	10	μA				
SLE/SLI	-	1	12	μA				

Notes:

- V<sub>IH</sub>(max) = V<sub>CC</sub> + 3.0V for pulse width less than 10ns.
- V<sub>IL</sub>(min) = V<sub>SS</sub> - 3.0V for pulse width less than 10ns.
- Over/Undershoot specifications are characterized, not 100% tested.
- Typical values are included for reference only and are not guaranteed or tested.  
Typical values are measured at V<sub>CC</sub> = V<sub>CC</sub>(TYP.) and T<sub>A</sub> = 25°C
- This parameter is measured at V<sub>CC</sub> = 3.0V



### CAPACITANCE (T<sub>A</sub> = 25°C, f = 1.0MHz)

PARAMETER	SYMBOL	MIN.	MAX	UNIT
Input Capacitance	C <sub>IN</sub>	-	6	pF
Input/Output Capacitance	C <sub>I/O</sub>	-	8	pF

Note : These parameters are guaranteed by device characterization, but not production tested.

### AC TEST CONDITIONS

Input Pulse Levels	0.2V to V <sub>CC</sub> - 0.2V
Input Rise and Fall Times	3ns
Input and Output Timing Reference Levels	1.5V
Output Load	C <sub>L</sub> = 30pF + 1TTL, I <sub>OH</sub> /I <sub>OL</sub> = -1mA/2mA

### AC ELECTRICAL CHARACTERISTICS

#### (1) READ CYCLE

PARAMETER	SYM.	LY62L5128-45		LY62L5128-55		LY62L5128-70		UNIT
		MIN.	MAX.	MIN.	MAX.	MIN.	MAX.	
Read Cycle Time	t <sub>RC</sub>	45	-	55	-	70	-	ns
Address Access Time	t <sub>AA</sub>	-	45	-	55	-	70	ns
Chip Enable Access Time	t <sub>ACE</sub>	-	45	-	55	-	70	ns
Output Enable Access Time	t <sub>OE</sub>	-	25	-	30	-	35	ns
Chip Enable to Output in Low-Z	t <sub>CLZ</sub> *	10	-	10	-	10	-	ns
Output Enable to Output in Low-Z	t <sub>OLZ</sub> *	5	-	5	-	5	-	ns
Chip Disable to Output in High-Z	t <sub>CHZ</sub> *	-	15	-	20	-	25	ns
Output Disable to Output in High-Z	t <sub>OHZ</sub> *	-	15	-	20	-	25	ns
Output Hold from Address Change	t <sub>OH</sub>	10	-	10	-	10	-	ns

#### (2) WRITE CYCLE

PARAMETER	SYM.	LY62L5128-45		LY62L5128-55		LY62L5128-70		UNIT
		MIN.	MAX.	MIN.	MAX.	MIN.	MAX.	
Write Cycle Time	t <sub>WC</sub>	45	-	55	-	70	-	ns
Address Valid to End of Write	t <sub>AW</sub>	40	-	50	-	60	-	ns
Chip Enable to End of Write	t <sub>CW</sub>	40	-	50	-	60	-	ns
Address Set-up Time	t <sub>AS</sub>	0	-	0	-	0	-	ns
Write Pulse Width	t <sub>WP</sub>	35	-	45	-	55	-	ns
Write Recovery Time	t <sub>WR</sub>	0	-	0	-	0	-	ns
Data to Write Time Overlap	t <sub>DW</sub>	20	-	25	-	30	-	ns
Data Hold from End of Write Time	t <sub>DH</sub>	0	-	0	-	0	-	ns
Output Active from End of Write	t <sub>OW</sub> *	5	-	5	-	5	-	ns
Write to Output in High-Z	t <sub>WHZ</sub> *	-	15	-	20	-	25	ns

\*These parameters are guaranteed by device characterization, but not production tested.



### TIMING WAVEFORMS

#### READ CYCLE 1 (Address Controlled) (1,2)

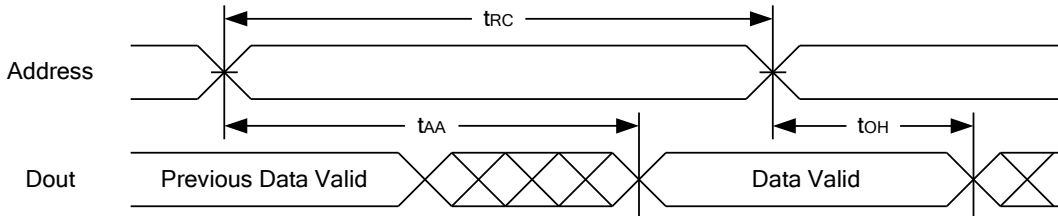

#### READ CYCLE 2 (CE# and OE# Controlled) (1,3,4,5)

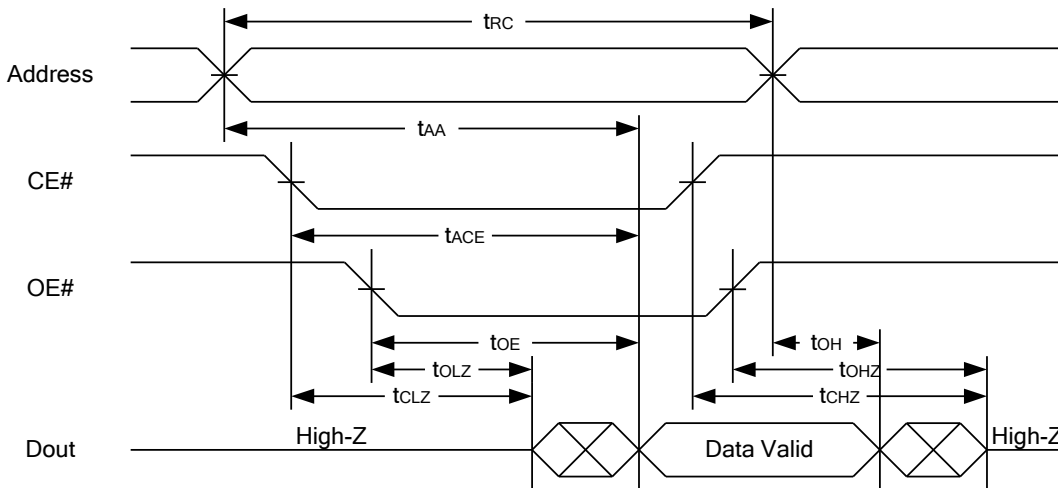

Notes :

1. WE# is high for read cycle.
2. Device is continuously selected OE# = low, CE# = low.
3. Address must be valid prior to or coincident with CE# = low,; otherwise tAA is the limiting parameter.
4. tCLZ, tOLZ, tCHZ and tOHZ are specified with CL = 5pF. Transition is measured ±500mV from steady state.
5. At any given temperature and voltage condition, tCHZ is less than tCLZ, tOHZ is less than tOLZ.







**DATA RETENTION CHARACTERISTICS**

PARAMETER	SYMBOL	TEST CONDITION	MIN.	TYP.	MAX.	UNIT		
V <sub>CC</sub> for Data Retention	V <sub>DR</sub>	CE# ≥ V <sub>CC</sub> - 0.2V or CE2 ≤ 0.2V	1.5	-	3.6	V		
Data Retention Current	I <sub>DR</sub>	V <sub>CC</sub> = 1.5V CE# ≥ V <sub>CC</sub> - 0.2V or CE2 ≤ 0.2V Other pins at 0.2V or V <sub>CC</sub> -0.2V	LL	-	1.0	12	μA	
			LLE/LLI	-	1.0	16	μA	
			SL	25°C	-	0.5	2.5	μA
			SLE	40°C	-	0.5	2.5	μA
			SLI	-	-	0.5	2.5	μA
			SL	-	-	0.5	8	μA
Chip Disable to Data Retention Time	t <sub>CDR</sub>	See Data Retention Waveforms (below)	0	-	-	ns		
Recovery Time	t <sub>R</sub>		t <sub>RC</sub> *	-	-	ns		

t<sub>RC</sub>\* = Read Cycle Time

**DATA RETENTION WAVEFORM**

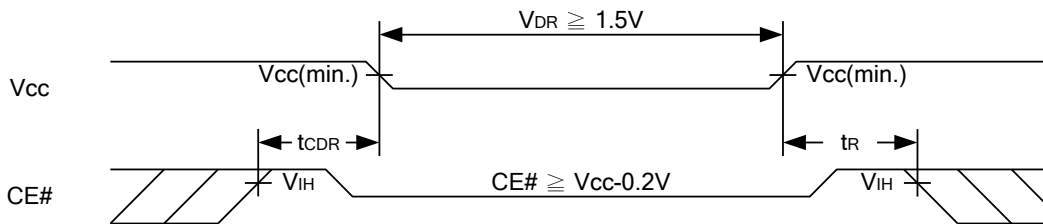



**PACKAGE OUTLINE DIMENSION**

**32 pin 450 mil SOP Package Outline Dimension**

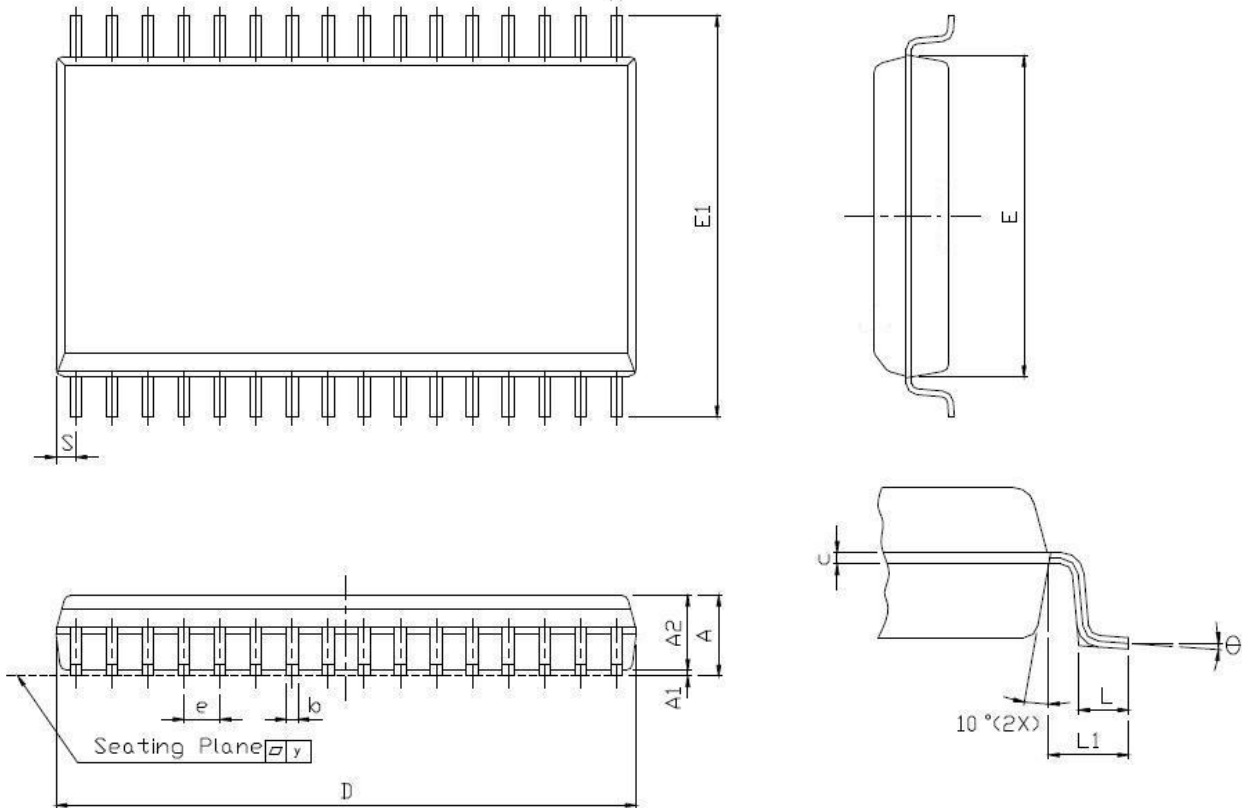

SYM.	UNIT	INCH.(BASE)	MM(REF)
A		0.120(MAX)	3.048(MAX)
A1		0.004(MIN)	0.102(MIN)
A2		0.116(MAX)	2.946(MAX)
b		0.016(TYP)	0.406(TYP)
c		0.008(TYP)	0.203(TYP)
D		0.817(MAX)	20.75(MAX)
E		0.445±0.006	11.303±0.152
E1		0.555±0.025	14.097±0.635
e		0.050(TYP)	1.270(TYP)
L		0.033±0.017	0.838±0.432
L1		0.055±0.008	1.397±0.203
S		0.026(MAX)	0.660(MAX)
y		0.004(MAX)	0.101(MAX)
Θ		0° -10°	0° -10°

**32 pin 600 mil PDIP Package Outline Dimension**

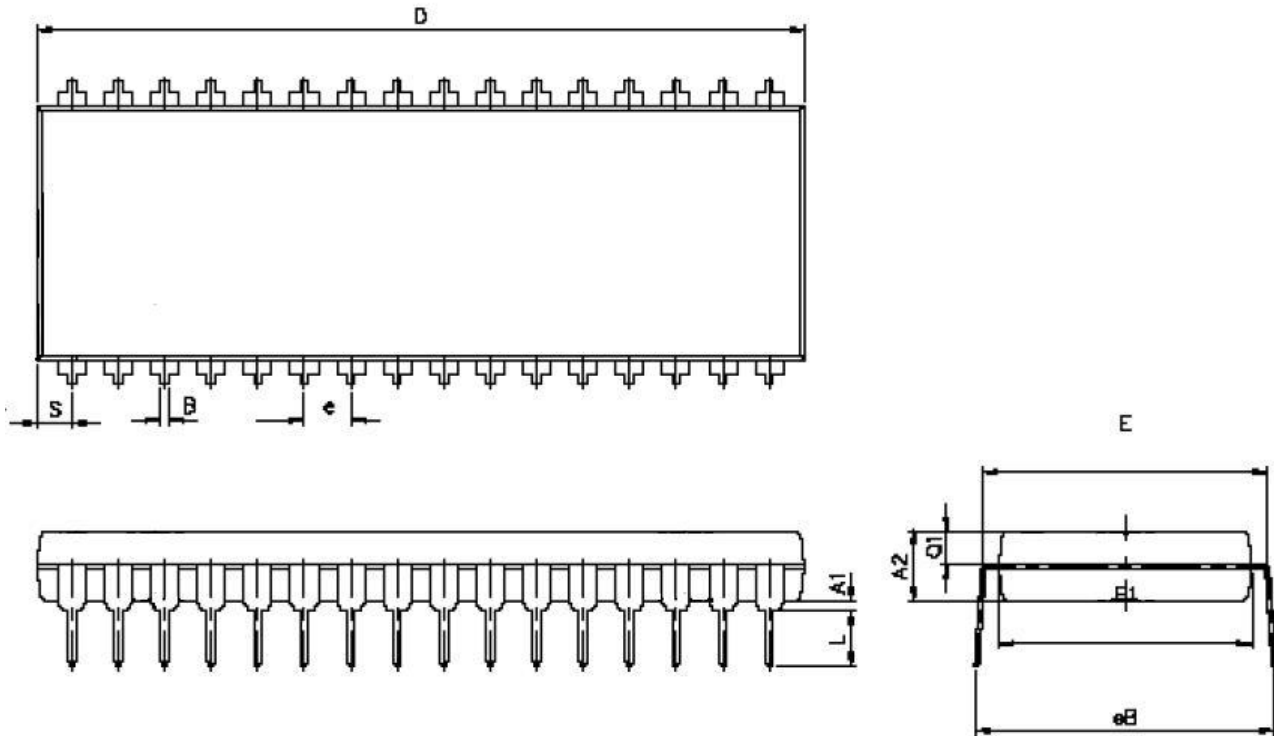

SYM. \ UNIT	INCH(BASE)	MM(REF)
A1	0.015(MIN)	0.381(MIN)
A2	0.155±0.005	3.937±0.127
B	0.018±0.005	0.457±0.127
D	1.650±0.01	41.910±0.254
E	0.600±0.010	15.240±0.254
E1	0.545±0.005	13.843±0.127
e	0.100(TYP)	2.540(TYP)
eB	0.650±0.020	16.510±0.508.
L	0.158±0.043	4.013±1.092
S	0.075±0.010	1.905±0.254
Q1	0.070±0.005	1.778±0.127

Note : D/E1/S dimension do not include mold flash.

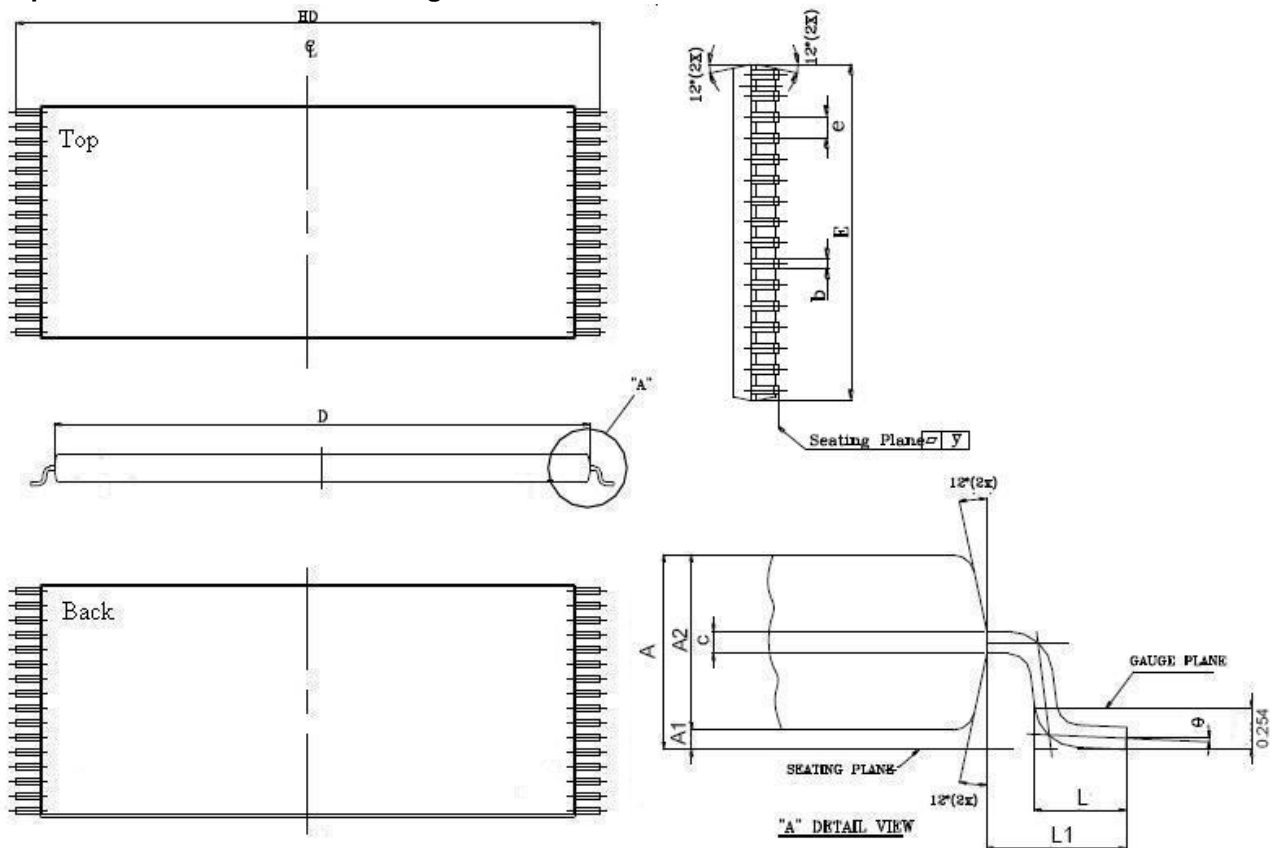
**32 pin 8mm x 20mm TSOP I Package Outline Dimension**

SYM.	UNIT	INCH(BASE)	MM(REF)
A		0.047 (MAX)	1.20 (MAX)
A1		0.004 $\pm$ 0.002	0.10 $\pm$ 0.05
A2		0.039 $\pm$ 0.002	1.00 $\pm$ 0.05
b		0.009 $\pm$ 0.002	0.22 $\pm$ 0.05
c		0.006 $\pm$ 0.002	0.155 $\pm$ 0.055
D		0.724 $\pm$ 0.008	18.40 $\pm$ 0.20
E		0.315 $\pm$ 0.008	8.00 $\pm$ 0.20
e		0.020 (TYP)	0.50 (TYP)
HD		0.787 $\pm$ 0.008	20.00 $\pm$ 0.20
L		0.024 $\pm$ 0.004	0.60 $\pm$ 0.10
L1		0.0315 $\pm$ 0.004	0.08 $\pm$ 0.10
y		0.003 (MAX)	0.08 (MAX)
$\theta$		0°~5°	0°~5°



**32 pin 8mm x 13.4mm sTSSOP Package Outline Dimension**

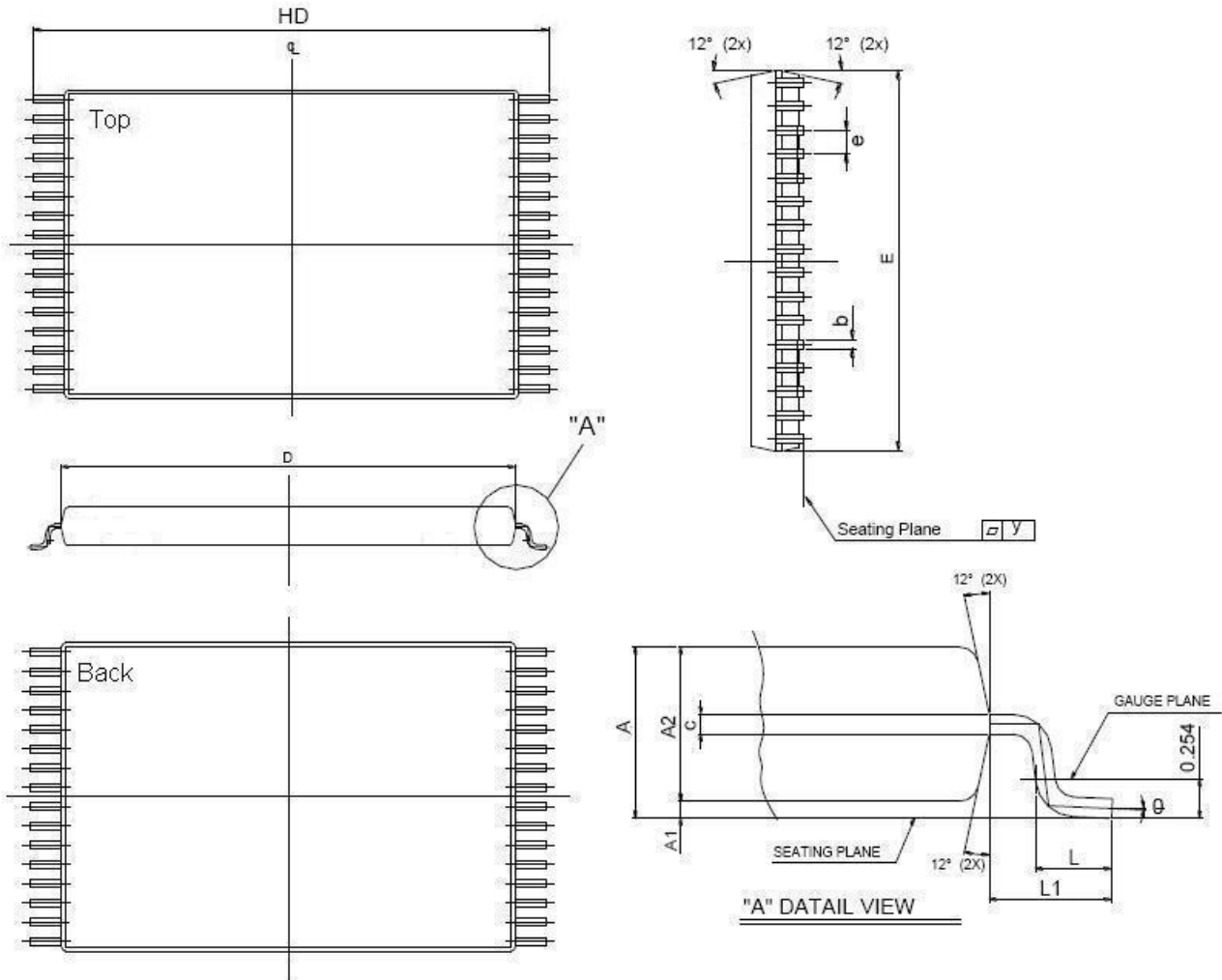

SYM.	UNIT	INCH(BASE)	MM(REF)
A		0.049 (MAX)	1.25 (MAX)
A1		0.004 ±0.002	0.10 ±0.05
A2		0.039 ±0.002	1.00 ±0.05
b		0.009 ±0.002	0.22 ±0.05
c		0.006 ±0.002	0.155 ±0.055
D		0.465 ±0.008	11.80 ±0.20
E		0.315 ±0.008	8.00 ±0.20
e		0.020 (TYP)	0.50 (TYP)
HD		0.528±0.008	13.40 ±0.20.
L		0.02 ±0.008	0.50 ±0.20
L1		0.031 ±0.005	0.8 ±0.125
y		0.003 (MAX)	0.076 (MAX)
θ		0°~5°	0°~5°

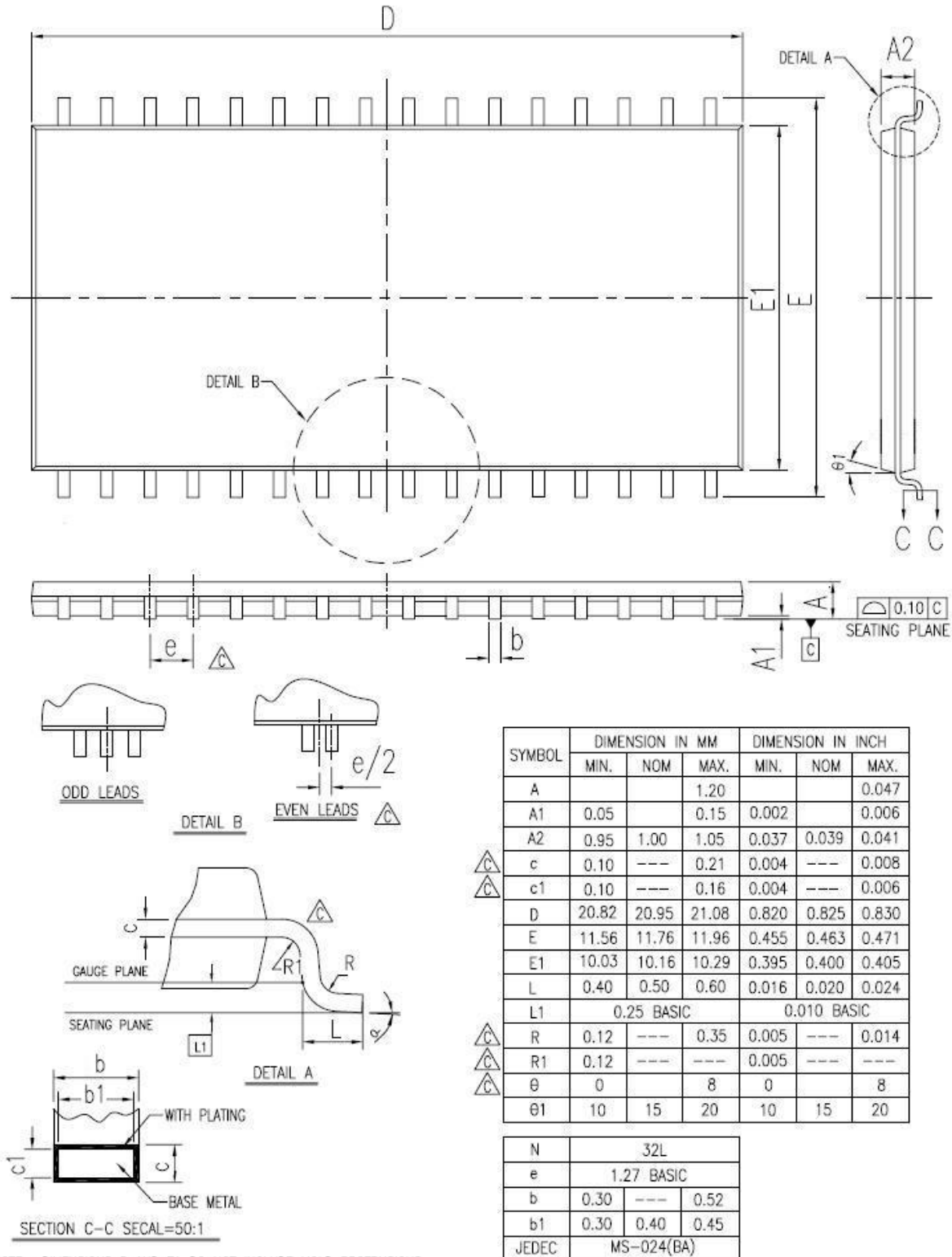
**32-pin 400mil TSOP II Package Outline Dimension**

NOTE : DIMENSIONS D AND E1 DO NOT INCLUDE MOLD PROTRUSIONS.  
D AND E1 ARE MAXIMUM PLASTIC BODY SIZE DIMENSIONS INCLUDING MOLD MISMATCH.

#### 36 ball 6mm x 8mm TFBGA Package Outline Dimension

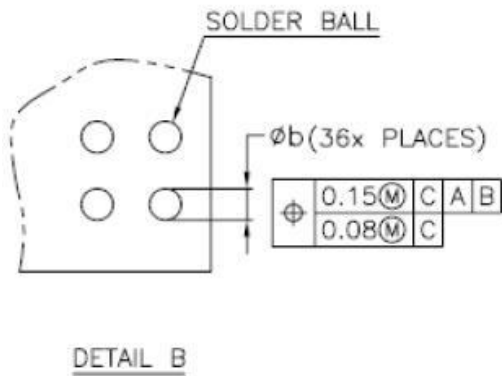
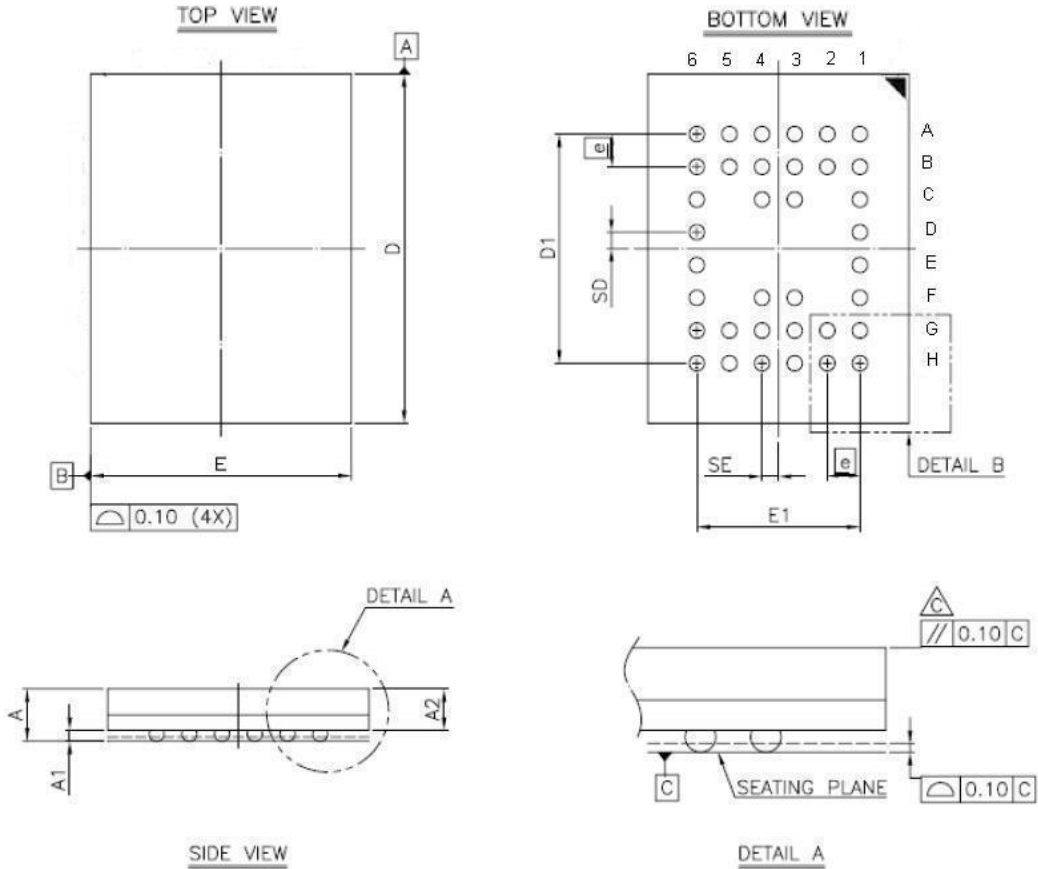

SYM.	DIMENSION (mm)			DIMENSION (inch)		
	MIN.	NOM.	MAX.	MIN.	NOM.	MAX.
A	—	—	1.20	—	—	0.047
A1	0.20	0.25	0.30	0.008	0.010	0.012
A2	—	—	0.94	—	—	0.037
b	0.30	0.35	0.40	0.012	0.014	0.016
D	7.95	8.00	8.05	0.313	0.315	0.317
D1	5.25 BSC			0.207 BSC		
E	5.95	6.00	6.05	0.234	0.236	0.238
E1	3.75 BSC			0.148 BSC		
SE	0.375 TYP			0.015 TYP		
SD	0.375 TYP			0.015 TYP		
e	0.75 BSC			0.030 BSC		

NOTE:

1. CONTROLLING DIMENSION : MILLIMETER.
2. REFERENCE DOCUMENT : JEDEC MO-207.



**ORDERING INFORMATION**

Package Type	Access Time (Speed)(ns)	Power Type	Temperature Range(°C)	Packing Type	Lyontek Item No.
32Pin(450mil) SOP	45	Special Ultra Low Power (SL)	0°C~70°C	Tube	LY62L5128SL-45SL
				Tape Reel	LY62L5128SL-45SLT
			-20°C~80°C	Tube	LY62L5128SL-45SLE
				Tape Reel	LY62L5128SL-45SLET
			-40°C~85°C	Tube	LY62L5128SL-45SLI
				Tape Reel	LY62L5128SL-45SLIT
		Ultra Low Power (LL)	0°C~70°C	Tube	LY62L5128SL-45LL
				Tape Reel	LY62L5128SL-45LLT
			-20°C~80°C	Tube	LY62L5128SL-45LLE
				Tape Reel	LY62L5128SL-45LLET
			-40°C~85°C	Tube	LY62L5128SL-45LLI
				Tape Reel	LY62L5128SL-45LLIT
	55	Special Ultra Low Power (SL)	0°C~70°C	Tube	LY62L5128SL-55SL
				Tape Reel	LY62L5128SL-55SLT
			-20°C~80°C	Tube	LY62L5128SL-55SLE
				Tape Reel	LY62L5128SL-55SLET
			-40°C~85°C	Tube	LY62L5128SL-55SLI
				Tape Reel	LY62L5128SL-55SLIT
		Ultra Low Power (LL)	0°C~70°C	Tube	LY62L5128SL-55LL
				Tape Reel	LY62L5128SL-55LLT
			-20°C~80°C	Tube	LY62L5128SL-55LLE
				Tape Reel	LY62L5128SL-55LLET
			-40°C~85°C	Tube	LY62L5128SL-55LLI
				Tape Reel	LY62L5128SL-55LLIT
70	Special Ultra Low Power (SL)	0°C~70°C	Tube	LY62L5128SL-70SL	
			Tape Reel	LY62L5128SL-70SLT	
		-20°C~80°C	Tube	LY62L5128SL-70SLE	
			Tape Reel	LY62L5128SL-70SLET	
		-40°C~85°C	Tube	LY62L5128SL-70SLI	
			Tape Reel	LY62L5128SL-70SLIT	
	Ultra Low Power (LL)	0°C~70°C	Tube	LY62L5128SL-70LL	
			Tape Reel	LY62L5128SL-70LLT	
		-20°C~80°C	Tube	LY62L5128SL-70LLE	
			Tape Reel	LY62L5128SL-70LLET	
		-40°C~85°C	Tube	LY62L5128SL-70LLI	
			Tape Reel	LY62L5128SL-70LLIT	





#### ORDERING INFORMATION

Package Type	Access Time (Speed)(ns)	Power Type	Temperature Range(°C)	Packing Type	Lyontek Item No.
32Pin(600mil) PDIP	45	Special	0°C~70°C	Tube	LY62L5128PL-45SL
		Ultra Low Power (SL)	-20°C~80°C	Tube	LY62L5128PL-45SLE
			-40°C~85°C	Tube	LY62L5128PL-45SLI
			0°C~70°C	Tube	LY62L5128PL-45LL
		Ultra Low Power (LL)	-20°C~80°C	Tube	LY62L5128PL-45LLE
			-40°C~85°C	Tube	LY62L5128PL-45LLI
	55		Special	0°C~70°C	Tube
		Ultra Low Power (SL)	-20°C~80°C	Tube	LY62L5128PL-55SLE
			-40°C~85°C	Tube	LY62L5128PL-55SLI
			0°C~70°C	Tube	LY62L5128PL-55LL
		Ultra Low Power (LL)	-20°C~80°C	Tube	LY62L5128PL-55LLE
			-40°C~85°C	Tube	LY62L5128PL-55LLI
	70		Special	0°C~70°C	Tube
		Ultra Low Power (SL)	-20°C~80°C	Tube	LY62L5128PL-70SLE
			-40°C~85°C	Tube	LY62L5128PL-70SLI
0°C~70°C			Tube	LY62L5128PL-70LL	
Ultra Low Power (LL)		-20°C~80°C	Tube	LY62L5128PL-70LLE	
		-40°C~85°C	Tube	LY62L5128PL-70LLI	



#### ORDERING INFORMATION

Package Type	Access Time (Speed)(ns)	Power Type	Temperature Range(°C)	Packing Type	Lyontek Item No.
32Pin (8mmx20mm) TSOP I	45	Special Ultra Low Power (SL)	0°C~70°C	Tray	LY62L5128LL-45SL
				Tape Reel	LY62L5128LL-45SLT
			-20°C~80°C	Tray	LY62L5128LL-45SLE
				Tape Reel	LY62L5128LL-45SLET
			-40°C~85°C	Tray	LY62L5128LL-45SLI
				Tape Reel	LY62L5128LL-45SLIT
		Ultra Low Power (LL)	0°C~70°C	Tray	LY62L5128LL-45LL
				Tape Reel	LY62L5128LL-45LLT
			-20°C~80°C	Tray	LY62L5128LL-45LLE
				Tape Reel	LY62L5128LL-45LLET
			-40°C~85°C	Tray	LY62L5128LL-45LLI
				Tape Reel	LY62L5128LL-45LLIT
	55	Special Ultra Low Power (SL)	0°C~70°C	Tray	LY62L5128LL-55SL
				Tape Reel	LY62L5128LL-55SLT
			-20°C~80°C	Tray	LY62L5128LL-55SLE
				Tape Reel	LY62L5128LL-55SLET
			-40°C~85°C	Tray	LY62L5128LL-55SLI
				Tape Reel	LY62L5128LL-55SLIT
		Ultra Low Power (LL)	0°C~70°C	Tray	LY62L5128LL-55LL
				Tape Reel	LY62L5128LL-55LLT
			-20°C~80°C	Tray	LY62L5128LL-55LLE
				Tape Reel	LY62L5128LL-55LLET
			-40°C~85°C	Tray	LY62L5128LL-55LLI
				Tape Reel	LY62L5128LL-55LLIT
70	Special Ultra Low Power (SL)	0°C~70°C	Tray	LY62L5128LL-70SL	
			Tape Reel	LY62L5128LL-70SLT	
		-20°C~80°C	Tray	LY62L5128LL-70SLE	
			Tape Reel	LY62L5128LL-70SLET	
		-40°C~85°C	Tray	LY62L5128LL-70SLI	
			Tape Reel	LY62L5128LL-70SLIT	
	Ultra Low Power (LL)	0°C~70°C	Tray	LY62L5128LL-70LL	
			Tape Reel	LY62L5128LL-70LLT	
		-20°C~80°C	Tray	LY62L5128LL-70LLE	
			Tape Reel	LY62L5128LL-70LLET	
		-40°C~85°C	Tray	LY62L5128LL-70LLI	
			Tape Reel	LY62L5128LL-70LLIT	



#### ORDERING INFORMATION

Package Type	Access Time (Speed)(ns)	Power Type	Temperature Range(°C)	Packing Type	Lyontek Item No.
32Pin (8mmx13.4mm) sTSOP	45	Special Ultra Low Power (SL)	0°C~70°C	Tray	LY62L5128RL-45SL
				Tape Reel	LY62L5128RL-45SLT
			-20°C~80°C	Tray	LY62L5128RL-45SLE
				Tape Reel	LY62L5128RL-45SLET
			-40°C~85°C	Tray	LY62L5128RL-45SLI
				Tape Reel	LY62L5128RL-45SLIT
		Ultra Low Power (LL)	0°C~70°C	Tray	LY62L5128RL-45LL
				Tape Reel	LY62L5128RL-45LLT
			-20°C~80°C	Tray	LY62L5128RL-45LLE
				Tape Reel	LY62L5128RL-45LLET
			-40°C~85°C	Tray	LY62L5128RL-45LLI
				Tape Reel	LY62L5128RL-45LLIT
	55	Special Ultra Low Power (SL)	0°C~70°C	Tray	LY62L5128RL-55SL
				Tape Reel	LY62L5128RL-55SLT
			-20°C~80°C	Tray	LY62L5128RL-55SLE
				Tape Reel	LY62L5128RL-55SLET
			-40°C~85°C	Tray	LY62L5128RL-55SLI
				Tape Reel	LY62L5128RL-55SLIT
		Ultra Low Power (LL)	0°C~70°C	Tray	LY62L5128RL-55LL
				Tape Reel	LY62L5128RL-55LLT
			-20°C~80°C	Tray	LY62L5128RL-55LLE
				Tape Reel	LY62L5128RL-55LLET
			-40°C~85°C	Tray	LY62L5128RL-55LLI
				Tape Reel	LY62L5128RL-55LLIT
70	Special Ultra Low Power (SL)	0°C~70°C	Tray	LY62L5128RL-70SL	
			Tape Reel	LY62L5128RL-70SLT	
		-20°C~80°C	Tray	LY62L5128RL-70SLE	
			Tape Reel	LY62L5128RL-70SLET	
		-40°C~85°C	Tray	LY62L5128RL-70SLI	
			Tape Reel	LY62L5128RL-70SLIT	
	Ultra Low Power (LL)	0°C~70°C	Tray	LY62L5128RL-70LL	
			Tape Reel	LY62L5128RL-70LLT	
		-20°C~80°C	Tray	LY62L5128RL-70LLE	
			Tape Reel	LY62L5128RL-70LLET	
		-40°C~85°C	Tray	LY62L5128RL-70LLI	
			Tape Reel	LY62L5128RL-70LLIT	



#### ORDERING INFORMATION

Package Type	Access Time (Speed)(ns)	Power Type	Temperature Range(°C)	Packing Type	Lyontek Item No.
32Pin(400mil) TSOP II	45	Special Ultra Low Power (SL)	0°C~70°C	Tray	LY62L5128WL-45SL
				Tape Reel	LY62L5128WL-45SLT
			-20°C~80°C	Tray	LY62L5128WL-45SLE
				Tape Reel	LY62L5128WL-45SLET
			-40°C~85°C	Tray	LY62L5128WL-45SLI
				Tape Reel	LY62L5128WL-45SLIT
		Ultra Low Power (LL)	0°C~70°C	Tray	LY62L5128WL-45LL
				Tape Reel	LY62L5128WL-45LLT
			-20°C~80°C	Tray	LY62L5128WL-45LLE
				Tape Reel	LY62L5128WL-45LLET
			-40°C~85°C	Tray	LY62L5128WL-45LLI
				Tape Reel	LY62L5128WL-45LLIT
	55	Special Ultra Low Power (SL)	0°C~70°C	Tray	LY62L5128WL-55SL
				Tape Reel	LY62L5128WL-55SLT
			-20°C~80°C	Tray	LY62L5128WL-55SLE
				Tape Reel	LY62L5128WL-55SLET
			-40°C~85°C	Tray	LY62L5128WL-55SLI
				Tape Reel	LY62L5128WL-55SLIT
		Ultra Low Power (LL)	0°C~70°C	Tray	LY62L5128WL-55LL
				Tape Reel	LY62L5128WL-55LLT
			-20°C~80°C	Tray	LY62L5128WL-55LLE
				Tape Reel	LY62L5128WL-55LLET
			-40°C~85°C	Tray	LY62L5128WL-55LLI
				Tape Reel	LY62L5128WL-55LLIT
70	Special Ultra Low Power (SL)	0°C~70°C	Tray	LY62L5128WL-70SL	
			Tape Reel	LY62L5128WL-70SLT	
		-20°C~80°C	Tray	LY62L5128WL-70SLE	
			Tape Reel	LY62L5128WL-70SLET	
		-40°C~85°C	Tray	LY62L5128WL-70SLI	
			Tape Reel	LY62L5128WL-70SLIT	
	Ultra Low Power (LL)	0°C~70°C	Tray	LY62L5128WL-70LL	
			Tape Reel	LY62L5128WL-70LLT	
		-20°C~80°C	Tray	LY62L5128WL-70LLE	
			Tape Reel	LY62L5128WL-70LLET	
		-40°C~85°C	Tray	LY62L5128WL-70LLI	
			Tape Reel	LY62L5128WL-70LLIT	



#### ORDERING INFORMATION

Package Type	Access Time (Speed)(ns)	Power Type	Temperature Range(°C)	Packing Type	Lyontek Item No.
36Ball (6mmx8mm) TFBGA	45	Special Ultra Low Power (SL)	0°C~70°C	Tray	LY62L5128GL-45SL
				Tape Reel	LY62L5128GL-45SLT
			-20°C~80°C	Tray	LY62L5128GL-45SLE
				Tape Reel	LY62L5128GL-45SLET
			-40°C~85°C	Tray	LY62L5128GL-45SLI
				Tape Reel	LY62L5128GL-45SLIT
		Ultra Low Power (LL)	0°C~70°C	Tray	LY62L5128GL-45LL
				Tape Reel	LY62L5128GL-45LLT
			-20°C~80°C	Tray	LY62L5128GL-45LLE
				Tape Reel	LY62L5128GL-45LLET
			-40°C~85°C	Tray	LY62L5128GL-45LLI
				Tape Reel	LY62L5128GL-45LLIT
	55	Special Ultra Low Power (SL)	0°C~70°C	Tray	LY62L5128GL-55SL
				Tape Reel	LY62L5128GL-55SLT
			-20°C~80°C	Tray	LY62L5128GL-55SLE
				Tape Reel	LY62L5128GL-55SLET
			-40°C~85°C	Tray	LY62L5128GL-55SLI
				Tape Reel	LY62L5128GL-55SLIT
		Ultra Low Power (LL)	0°C~70°C	Tray	LY62L5128GL-55LL
				Tape Reel	LY62L5128GL-55LLT
			-20°C~80°C	Tray	LY62L5128GL-55LLE
				Tape Reel	LY62L5128GL-55LLET
			-40°C~85°C	Tray	LY62L5128GL-55LLI
				Tape Reel	LY62L5128GL-55LLIT
70	Special Ultra Low Power (SL)	0°C~70°C	Tray	LY62L5128GL-70SL	
			Tape Reel	LY62L5128GL-70SLT	
		-20°C~80°C	Tray	LY62L5128GL-70SLE	
			Tape Reel	LY62L5128GL-70SLET	
		-40°C~85°C	Tray	LY62L5128GL-70SLI	
			Tape Reel	LY62L5128GL-70SLIT	
	Ultra Low Power (LL)	0°C~70°C	Tray	LY62L5128GL-70LL	
			Tape Reel	LY62L5128GL-70LLT	
		-20°C~80°C	Tray	LY62L5128GL-70LLE	
			Tape Reel	LY62L5128GL-70LLET	
		-40°C~85°C	Tray	LY62L5128GL-70LLI	
			Tape Reel	LY62L5128GL-70LLIT	



**Lyontek Inc.**

Rev. 1.14

**LY62L5128**  
**512K X 8 BIT LOW POWER CMOS SRAM**

---

THIS PAGE IS LEFT BLANK INTENTIONALLY.