

MITSUBISHI MICROCOMPUTERS 3850 Group

SINGLE-CHIP 8-BIT CMOS MICROCOMPUTER

DESCRIPTION

The 3850 group is the 8-bit microcomputer based on the 740 family core technology.

The 3850 group is designed for the household products and office automation equipment and includes serial I/O functions, 8-bit timer, and A-D converter.

FEATURES

- Basic machine-language instructions 71
- Minimum instruction execution time 0.5 μ s
(at 8 MHz oscillation frequency)
- Memory size
 - ROM 8K to 24K bytes
 - RAM 512 to 640 byte
- Programmable input/output ports 34
- Interrupts 14 sources, 14 vectors
- Timers 8-bit X 4
- Serial I/O 8-bit X 1 (UART or Clock-synchronized)
- PWM 8-bit X 1
- A-D converter 10-bit X 5 channels
- Watchdog timer 16-bit X 1
- Clock generating circuit Built-in 2 circuits
(connect to external ceramic resonator or quartz-crystal oscillator)

- Power source voltage
 - In high-speed mode 4.0 to 5.5 V
(at 8 MHz oscillation frequency)
 - In high-speed mode 2.7 to 5.5 V
(at 4 MHz oscillation frequency)
 - In middle-speed mode 2.7 to 5.5 V
(at 8 MHz oscillation frequency)
 - In low-speed mode 2.7 to 5.5 V
(at 32 kHz oscillation frequency)
- Power dissipation
 - In high-speed mode 34 mW
(at 8 MHz oscillation frequency, at 5 V power source voltage)
 - In low-speed mode 60 μ W
(at 32 kHz oscillation frequency, at 3 V power source voltage)
- Operating temperature range -20 to 85°C

APPLICATION

Office automation equipment, FA equipment, Household products, Consumer electronics, etc.

PIN CONFIGURATION (TOP VIEW)

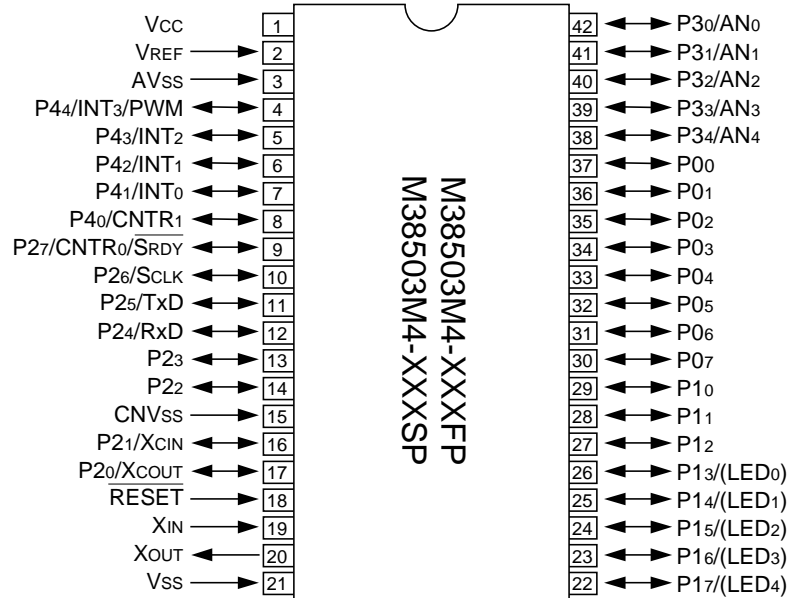

Package type : FP 42P2R-A (42-pin plastic-molded SSOP)
 Package type : SP 42P4B (42-pin shrink plastic-molded DIP)

Fig. 1 M38503M4-XXXXFP/SP pin configuration

FUNCTIONAL BLOCK

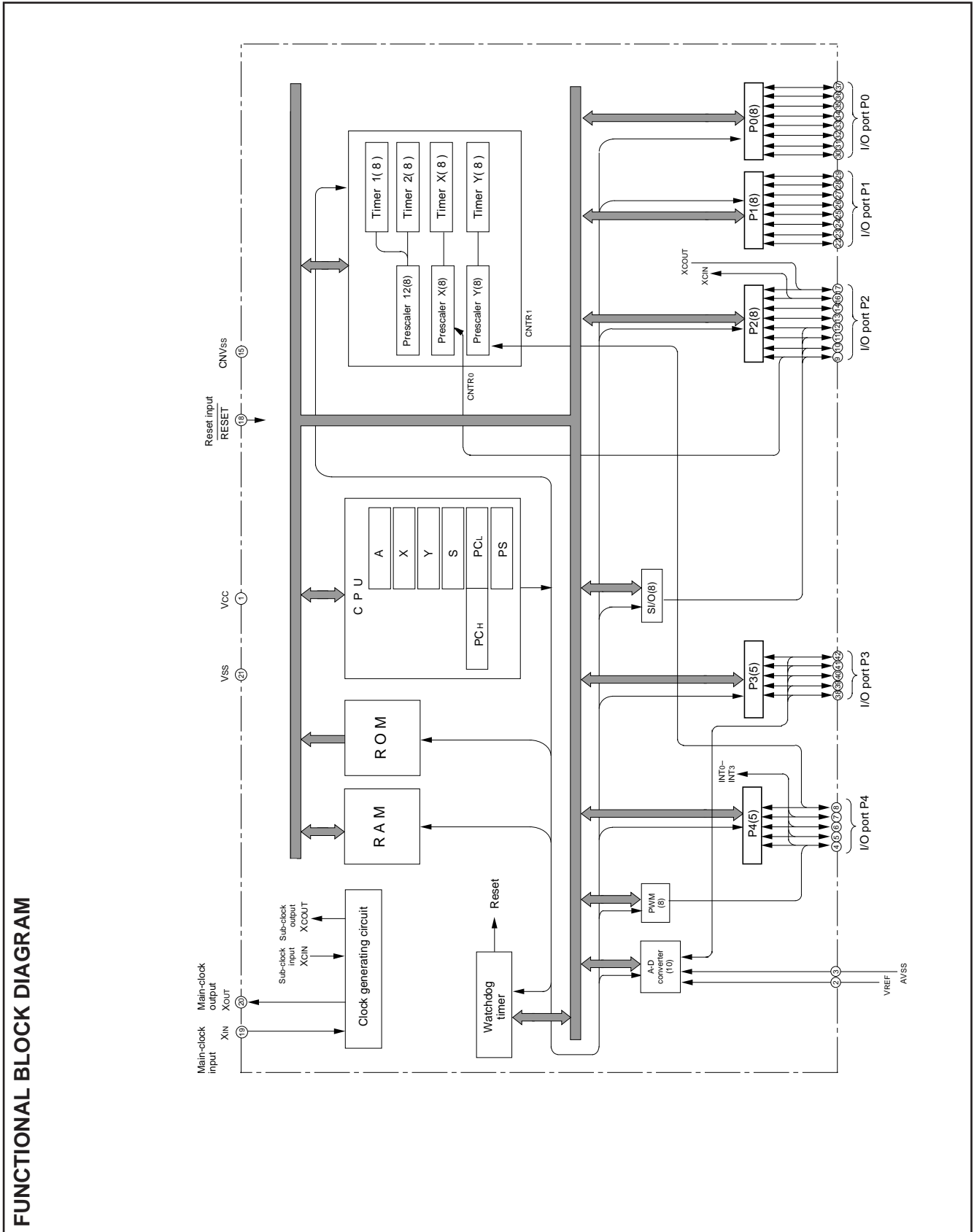

Fig. 2 Functional block diagram

PIN DESCRIPTION

Table 1 Pin description

Pin	Name	Functions	
			Function except a port function
VCC, VSS	Power source	•Apply voltage of 2.7 V – 5.5 V to Vcc, and 0 V to Vss.	
CNVSS	CNVSS input	•This pin controls the operation mode of the chip. •Normally connected to VSS.	
RESET	Reset input	•Reset input pin for active “L.”	
XIN	Clock input	•Input and output pins for the clock generating circuit. •Connect a ceramic resonator or quartz-crystal oscillator between the XIN and XOUT pins to set the oscillation frequency.	
XOUT	Clock output	•When an external clock is used, connect the clock source to the XIN pin and leave the XOUT pin open.	
P00–P07	I/O port P0	•8-bit CMOS I/O port. •I/O direction register allows each pin to be individually programmed as either input or output. •CMOS compatible input level.	
P10–P17	I/O port P1	•CMOS 3-state output structure. •P13 to P17 (5 bits) are enabled to output large current for LED drive.	
P20/XCOUT P21/XCIN	I/O port P2	•8-bit CMOS I/O port. •I/O direction register allows each pin to be individually programmed as either input or output. •CMOS compatible input level. •P20, P21, P24 to P27: CMOS3-state output structure. •P22, P23: N-channel open-drain structure.	• Sub-clock generating circuit I/O pins (connect a resonator)
P22 P23			
P24/RxD P25/TxD			• Serial I/O function pin
P26/SCLK			
P27/CNTR0/ SRDY			• Serial I/O function pin/ Timer X function pin
P30/AN0– P34/AN4	I/O port P3	•8-bit CMOS I/O port with the same function as port P0. •CMOS compatible input level. •CMOS 3-state output structure.	• A-D converter input pin
P40/CNTR1	I/O port P4	•8-bit CMOS I/O port with the same function as port P0. •CMOS compatible input level. •CMOS 3-state output structure.	• Timer Y function pin
P41/INT0– P43/INT2			• Interrupt input pins
P44/INT3/PWM			• Interrupt input pin • PWM output pin

PART NUMBERING

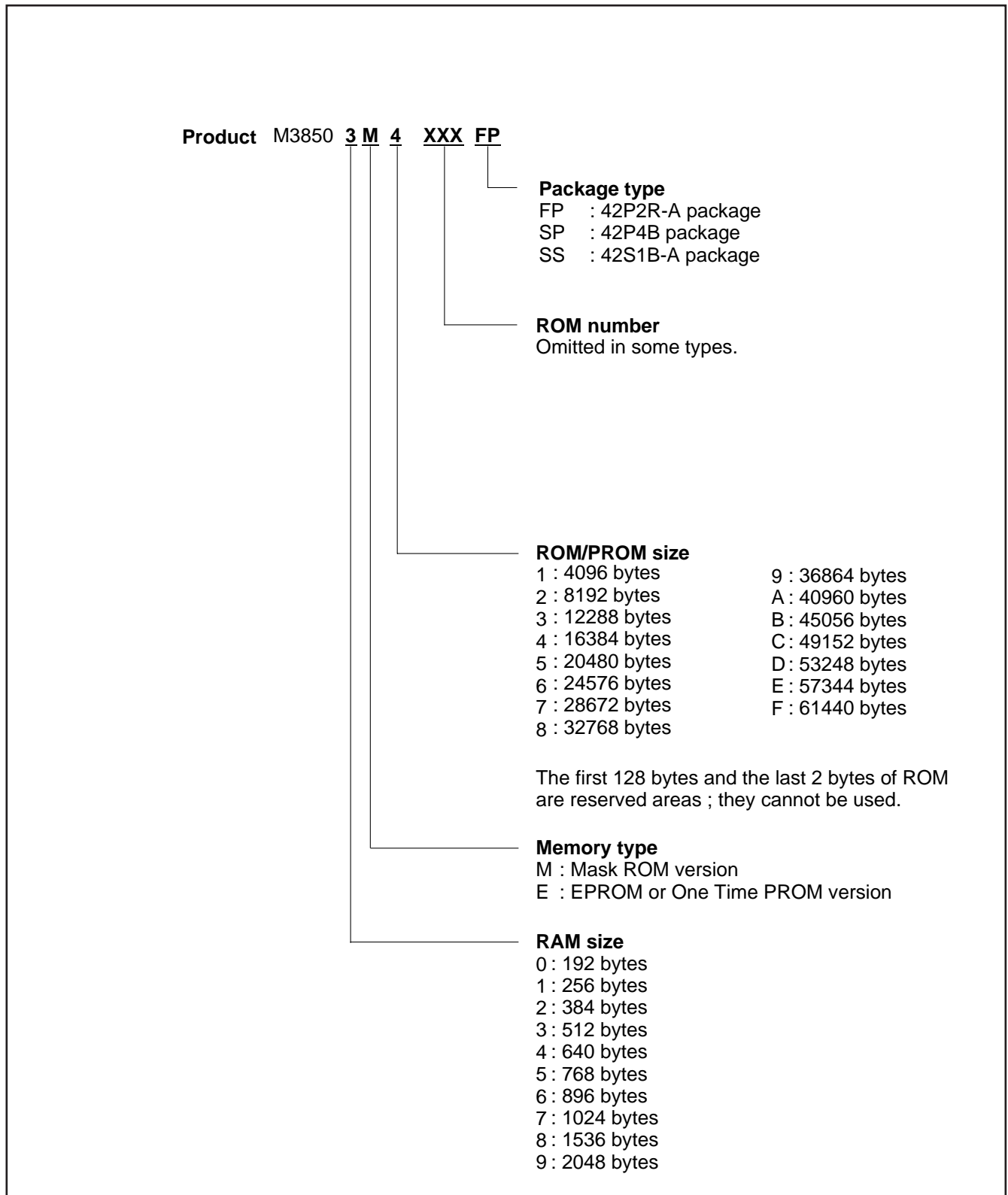

Fig. 3 Part numbering

GROUP EXPANSION

Mitsubishi plans to expand the 3850 group as follows:

Memory Type

Support for mask ROM, One Time PROM, and EPROM versions.

Memory Size

ROM/PROM size 8K to 24K bytes

RAM size 512 to 640 bytes

Packages

42P4B.....42-pin shrink plastic molded DIP

42P2R-A 42-pin plastic molded SSOP

42S1B-A 42-pin shrink ceramic DIP(EPROM version)

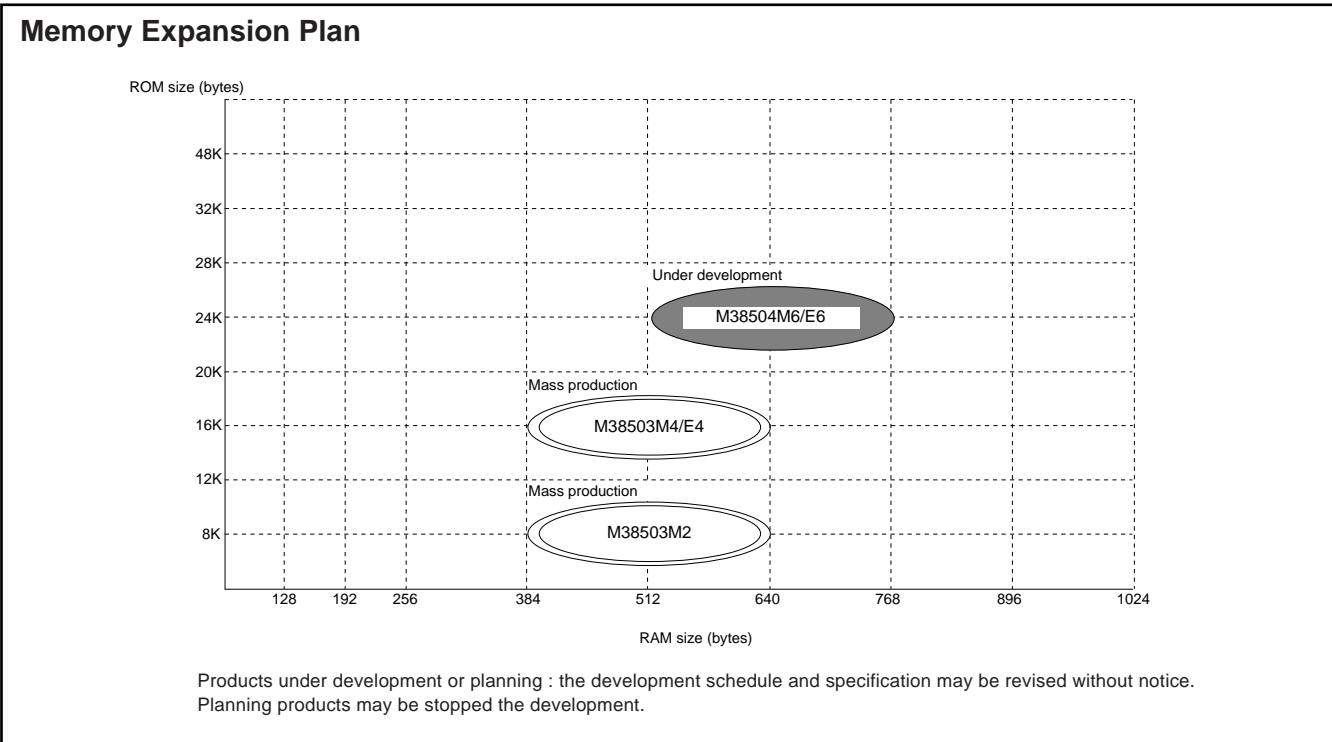

Fig. 4 Memory expansion plan

Currently planning products are listed below.

Table 2 Support products

As of August 1998

Product name	(P) ROM size (bytes) ROM size for User in ()	RAM size (bytes)	Package	Remarks
M38503M2-XXXSP	8192 (8062)	512	42P4B	Mask ROM version
M38503M2-XXXFP			42P2R-A	Mask ROM version
M38503M4-XXXSP	16384 (16254)	512	42P4B	Mask ROM version
M38503E4-XXXSP				One Time PROM version
M38503E4SP			One Time PROM version (blank)	
M38503E4SS			42S1B-A	EPROM version (stock only replaced by M38504E6SS)
M38503M4-XXXFP			42P2R-A	Mask ROM version
M38503E4-XXXFP				One Time PROM version
M38503E4FP				One Time PROM version (blank)
M38504M6-XXXSP			32768 (32638)	640
M38504E6-XXXSP	One Time PROM version			
M38504E6SP	One Time PROM version (blank)			
M38504E6SS	42S1B-A	EPROM version		
M38504M6-XXXFP	42P2R-A	Mask ROM version		
M38504E6-XXXFP		One Time PROM version		
M38504E6FP		One Time PROM version (blank)		

FUNCTIONAL DESCRIPTION

CENTRAL PROCESSING UNIT (CPU)

The 3850 group uses the standard 740 Family instruction set. Refer to the table of 740 Family addressing modes and machine instructions or the 740 Family Software Manual for details on the instruction set.

Machine-resident 740 Family instructions are as follows:

The FST and SLW instructions cannot be used.

The STP, WIT, MUL, and DIV instructions can be used.

[CPU Mode Register (CPUM)] 003B16

The CPU mode register contains the stack page selection bit, etc.

The CPU mode register is allocated at address 003B16.

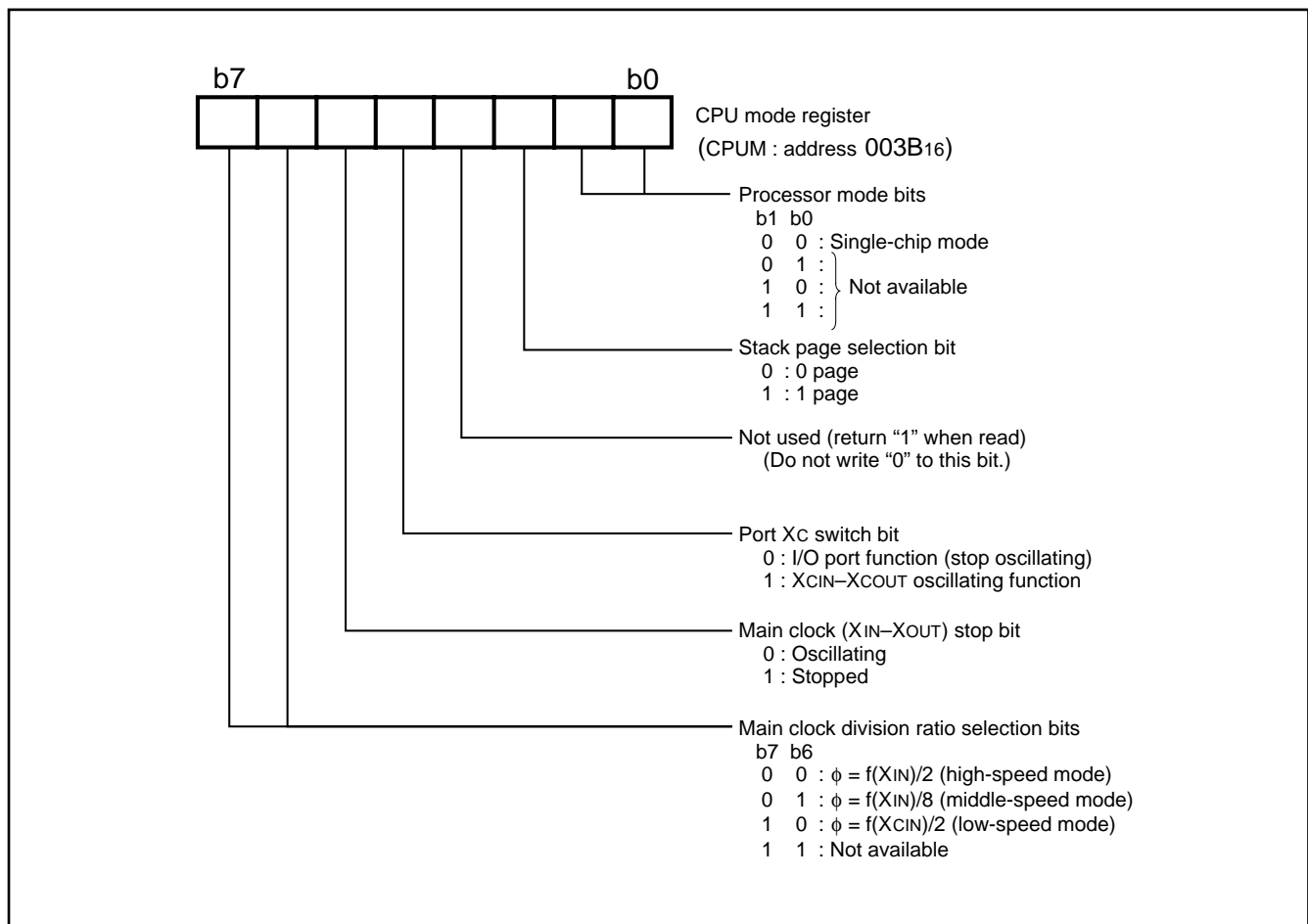

Fig. 5 Structure of CPU mode register

MEMORY

Special Function Register (SFR) Area

The Special Function Register area in the zero page contains control registers such as I/O ports and timers.

RAM

RAM is used for data storage and for stack area of subroutine calls and interrupts.

ROM

The first 128 bytes and the last 2 bytes of ROM are reserved for device testing and the rest is user area for storing programs.

Interrupt Vector Area

The interrupt vector area contains reset and interrupt vectors.

Zero Page

Access to this area with only 2 bytes is possible in the zero page addressing mode.

Special Page

Access to this area with only 2 bytes is possible in the special page addressing mode.

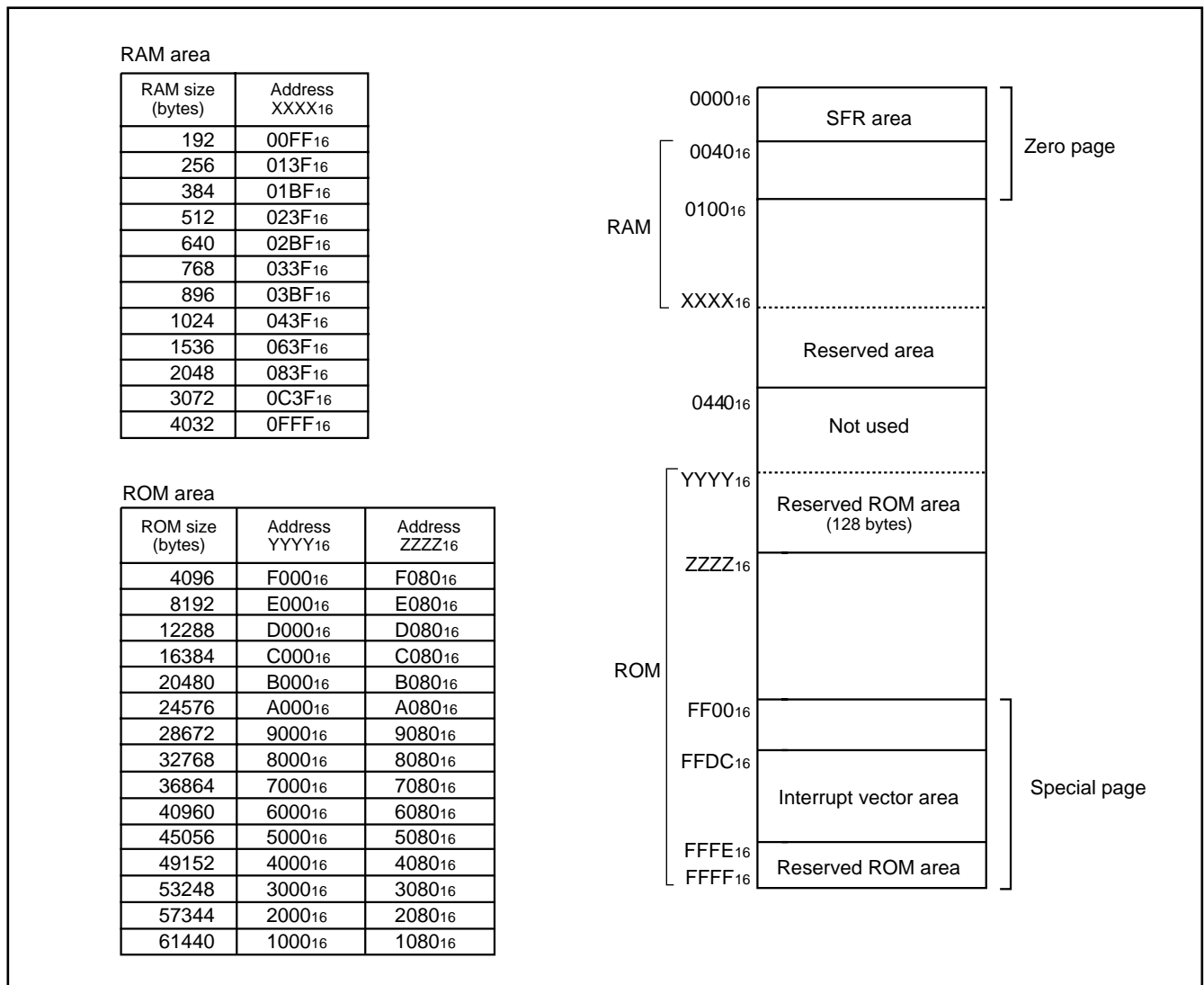

Fig. 6 Memory map diagram

0000 ₁₆	Port P0 (P0)	0020 ₁₆	Prescaler 12 (PRE12)
0001 ₁₆	Port P0 direction register (P0D)	0021 ₁₆	Timer 1 (T1)
0002 ₁₆	Port P1 (P1)	0022 ₁₆	Timer 2 (T2)
0003 ₁₆	Port P1 direction register (P1D)	0023 ₁₆	Timer XY mode register (TM)
0004 ₁₆	Port P2 (P2)	0024 ₁₆	Prescaler X (PREX)
0005 ₁₆	Port P2 direction register (P2D)	0025 ₁₆	Timer X (TX)
0006 ₁₆	Port P3 (P3)	0026 ₁₆	Prescaler Y (PREY)
0007 ₁₆	Port P3 direction register (P3D)	0027 ₁₆	Timer Y (TY)
0008 ₁₆	Port P4 (P4)	0028 ₁₆	Timer count source selection register (TCSS)
0009 ₁₆	Port P4 direction register (P4D)	0029 ₁₆	
000A ₁₆		002A ₁₆	
000B ₁₆		002B ₁₆	Reserved *
000C ₁₆		002C ₁₆	Reserved *
000D ₁₆		002D ₁₆	Reserved *
000E ₁₆		002E ₁₆	Reserved *
000F ₁₆		002F ₁₆	Reserved *
0010 ₁₆		0030 ₁₆	Reserved *
0011 ₁₆		0031 ₁₆	
0012 ₁₆		0032 ₁₆	
0013 ₁₆		0033 ₁₆	
0014 ₁₆		0034 ₁₆	A-D control register (ADCON)
0015 ₁₆	Reserved *	0035 ₁₆	A-D conversion low-order register (ADL)
0016 ₁₆	Reserved *	0036 ₁₆	A-D conversion high-order register (ADH)
0017 ₁₆	Reserved *	0037 ₁₆	
0018 ₁₆	Transmit/Receive buffer register (TB/RB)	0038 ₁₆	MISRG
0019 ₁₆	Serial I/O status register (SIOSTS)	0039 ₁₆	Watchdog timer control register (WDTCON)
001A ₁₆	Serial I/O control register (SIOCON)	003A ₁₆	Interrupt edge selection register (INTEDGE)
001B ₁₆	UART control register (UARTCON)	003B ₁₆	CPU mode register (CPUM)
001C ₁₆	Baud rate generator (BRG)	003C ₁₆	Interrupt request register 1 (IREQ1)
001D ₁₆	PWM control register (PWMCON)	003D ₁₆	Interrupt request register 2 (IREQ2)
001E ₁₆	PWM prescaler (PREPWM)	003E ₁₆	Interrupt control register 1 (ICON1)
001F ₁₆	PWM register (PWM)	003F ₁₆	Interrupt control register 2 (ICON2)

* Reserved : Do not write "1" to this address.

Fig. 7 Memory map of special function register (SFR)

I/O PORTS

The I/O ports have direction registers which determine the input/output direction of each individual pin. Each bit in a direction register corresponds to one pin, and each pin can be set to be input port or output port.

When "0" is written to the bit corresponding to a pin, that pin becomes an input pin. When "1" is written to that bit, that pin becomes an output pin.

If data is read from a pin which is set to output, the value of the port output latch is read, not the value of the pin itself. Pins set to input are floating. If a pin set to input is written to, only the port output latch is written to and the pin remains floating.

Table 3 I/O port function

Pin	Name	Input/Output	I/O Structure	Non-Port Function	Related SFRs	Ref.No.
P00–P07	Port P0	Input/output, individual bits	CMOS compatible input level CMOS 3-state output			(1)
P10–P17	Port P1			Sub-clock generating circuit	CPU mode register	(2) (3)
P20/XCOUT P21/XCIN	Port P2		CMOS compatible input level N-channel open-drain output			(4)
P22 P23			CMOS compatible input level CMOS 3-state output	Serial I/O function I/O	Serial I/O control register	(5) (6)
P24/RxD P25/TxD				Serial I/O function I/O	Serial I/O control register	(7)
P26/SCLK				Serial I/O function I/O Timer X function I/O	Serial I/O control register Timer XY mode register	(8)
P27/CNTR0/ $\overline{\text{SRDY}}$			Port P3	A-D conversion input	A-D control register	(9)
P30/AN0– P34/AN4	Timer Y function I/O			Timer XY mode register	(10)	
P40/CNTR1	Port P4		External interrupt input	Interrupt edge selection register	(11)	
P41/INT0– P43/INT2			External interrupt input PWM output	Interrupt edge selection register PWM control register	(12)	
P44/INT3/PWM						

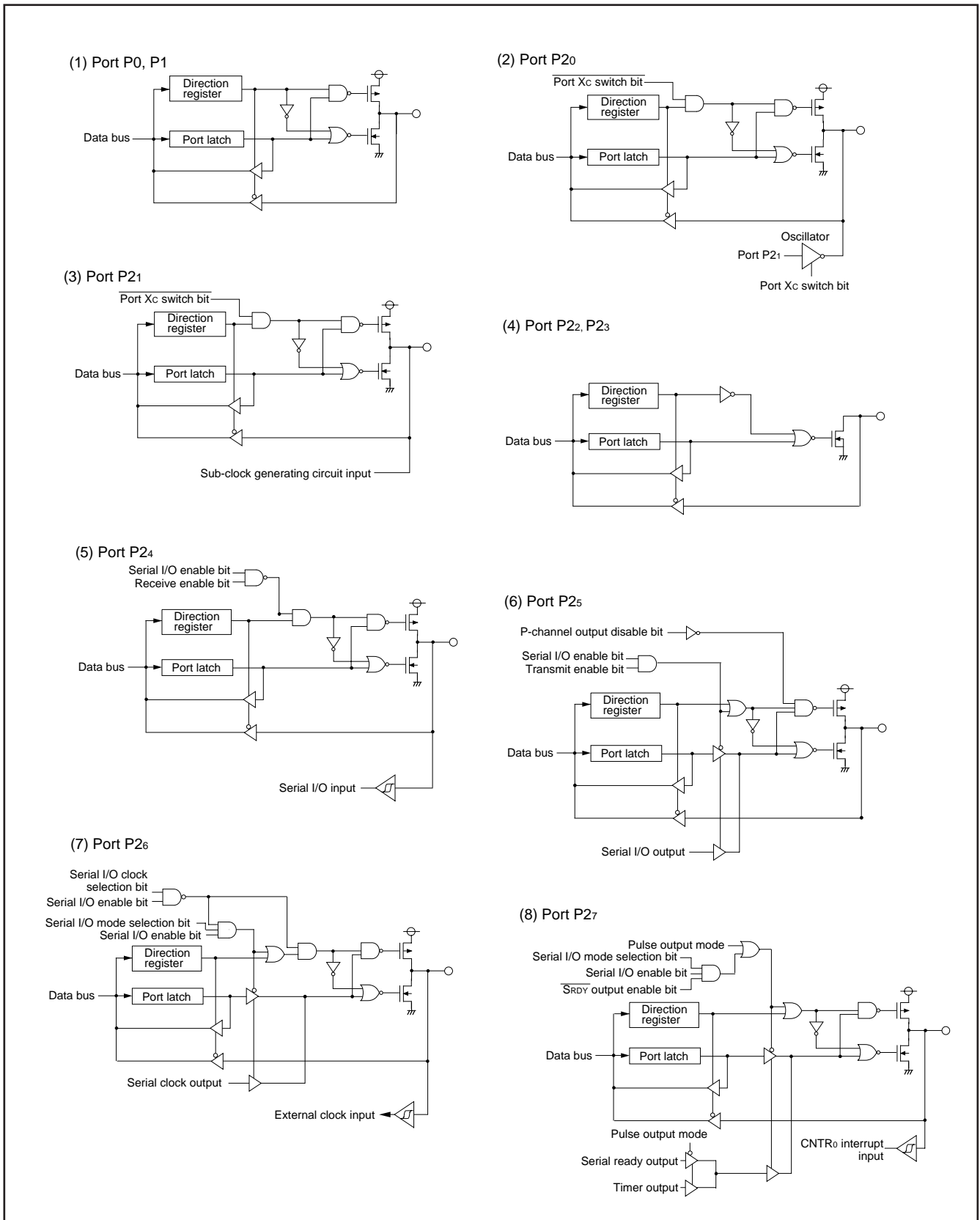

Fig. 8 Port block diagram (1)

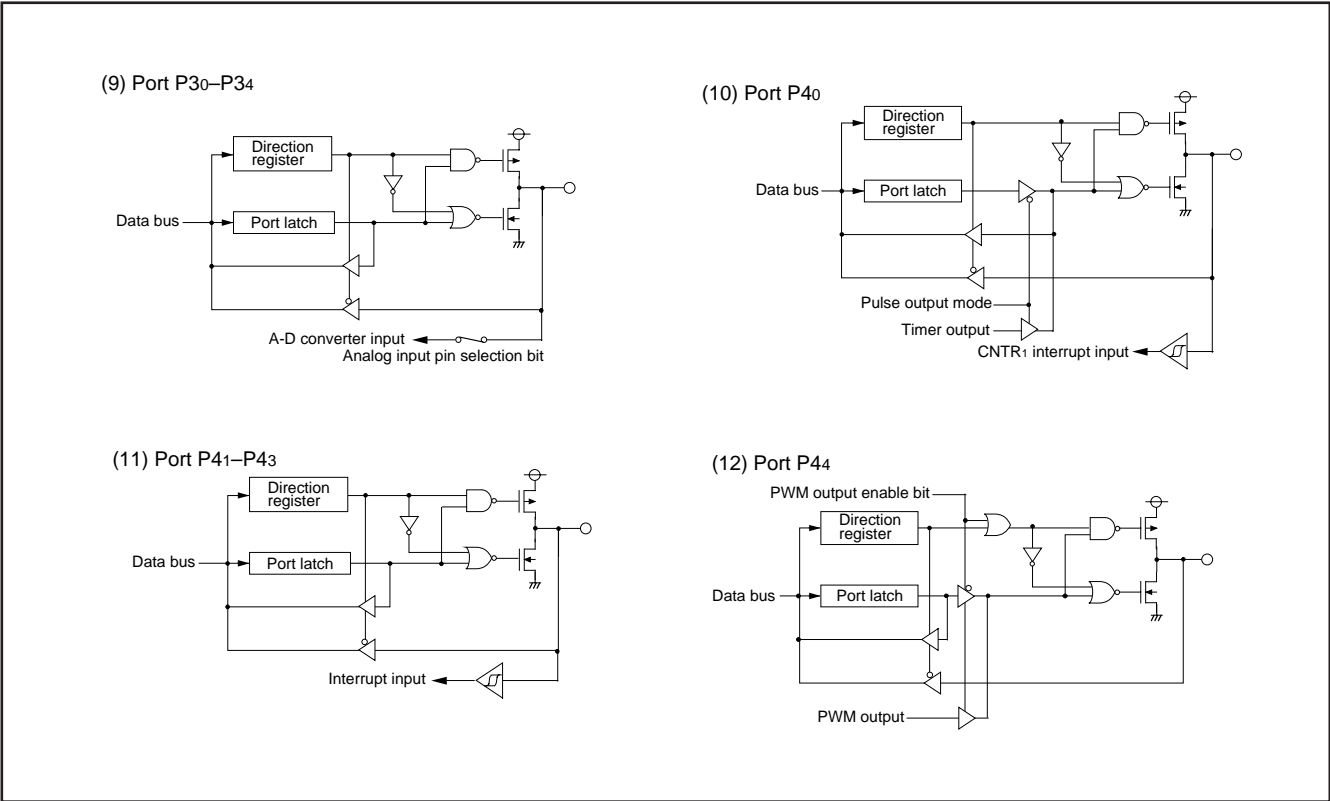

Fig. 9 Port block diagram (2)

INTERRUPTS

Interrupts occur by 14 sources among 14 sources: six external, seven internal, and one software.

Interrupt Control

Each interrupt is controlled by an interrupt request bit, an interrupt enable bit, and the interrupt disable flag except for the software interrupt set by the BRK instruction. An interrupt occurs if the corresponding interrupt request and enable bits are "1" and the interrupt disable flag is "0".

Interrupt enable bits can be set or cleared by software.

Interrupt request bits can be cleared by software, but cannot be set by software.

The BRK instruction cannot be disabled with any flag or bit. The I (interrupt disable) flag disables all interrupts except the BRK instruction interrupt.

When several interrupts occur at the same time, the interrupts are received according to priority.

Interrupt Operation

By acceptance of an interrupt, the following operations are automatically performed:

1. The contents of the program counter and the processor status register are automatically pushed onto the stack.
2. The interrupt disable flag is set and the corresponding interrupt request bit is cleared.
3. The interrupt jump destination address is read from the vector table into the program counter.

■Notes

When the active edge of an external interrupt (INT₀–INT₃, CNTR₀, CNTR₁) is set, the corresponding interrupt request bit may also be set. Therefore, take the following sequence:

1. Disable the interrupt
2. Change the interrupt edge selection register (the timer XY mode register for CNTR₀ and CNTR₁)
3. Clear the interrupt request bit to "0"
4. Accept the interrupt.

Table 4 Interrupt vector addresses and priority

Interrupt Source	Priority	Vector Addresses (Note 1)		Interrupt Request Generating Conditions	Remarks
		High	Low		
Reset (Note 2)	1	FFFD ₁₆	FFFC ₁₆	At reset	Non-maskable
INT ₀	2	FFFB ₁₆	FFFA ₁₆	At detection of either rising or falling edge of INT ₀ input	External interrupt (active edge selectable)
Reserved	3	FFF9 ₁₆	FFF8 ₁₆	Reserved	
INT ₁	4	FFF7 ₁₆	FFF6 ₁₆	At detection of either rising or falling edge of INT ₁ input	External interrupt (active edge selectable)
INT ₂	5	FFF5 ₁₆	FFF4 ₁₆	At detection of either rising or falling edge of INT ₂ input	External interrupt (active edge selectable)
INT ₃	6	FFF3 ₁₆	FFF2 ₁₆	At detection of either rising or falling edge of INT ₃ input	External interrupt (active edge selectable)
Reserved	7	FFF1 ₁₆	FFF0 ₁₆	Reserved	
Timer X	8	FFEF ₁₆	FFEE ₁₆	At timer X underflow	
Timer Y	9	FFED ₁₆	FFEC ₁₆	At timer Y underflow	
Timer 1	10	FFEB ₁₆	FFEA ₁₆	At timer 1 underflow	STP release timer underflow
Timer 2	11	FFE9 ₁₆	FFE8 ₁₆	At timer 2 underflow	
Serial I/O reception	12	FFE7 ₁₆	FFE6 ₁₆	At completion of serial I/O data reception	Valid when serial I/O is selected
Serial I/O Transmission	13	FFE5 ₁₆	FFE4 ₁₆	At completion of serial I/O transfer shift or when transmission buffer is empty	Valid when serial I/O is selected
CNTR ₀	14	FFE3 ₁₆	FFE2 ₁₆	At detection of either rising or falling edge of CNTR ₀ input	External interrupt (active edge selectable)
CNTR ₁	15	FFE1 ₁₆	FFE0 ₁₆	At detection of either rising or falling edge of CNTR ₁ input	External interrupt (active edge selectable)
A-D converter	16	FFDF ₁₆	FFDE ₁₆	At completion of A-D conversion	
BRK instruction	17	FFDD ₁₆	FFDC ₁₆	At BRK instruction execution	Non-maskable software interrupt

Notes 1: Vector addresses contain interrupt jump destination addresses.

2: Reset function in the same way as an interrupt with the highest priority.

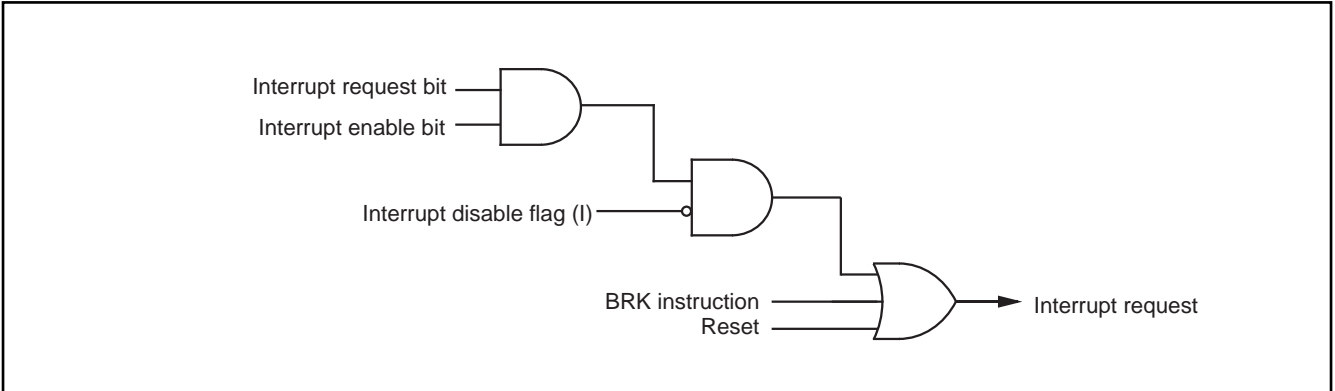

Fig. 10 Interrupt control

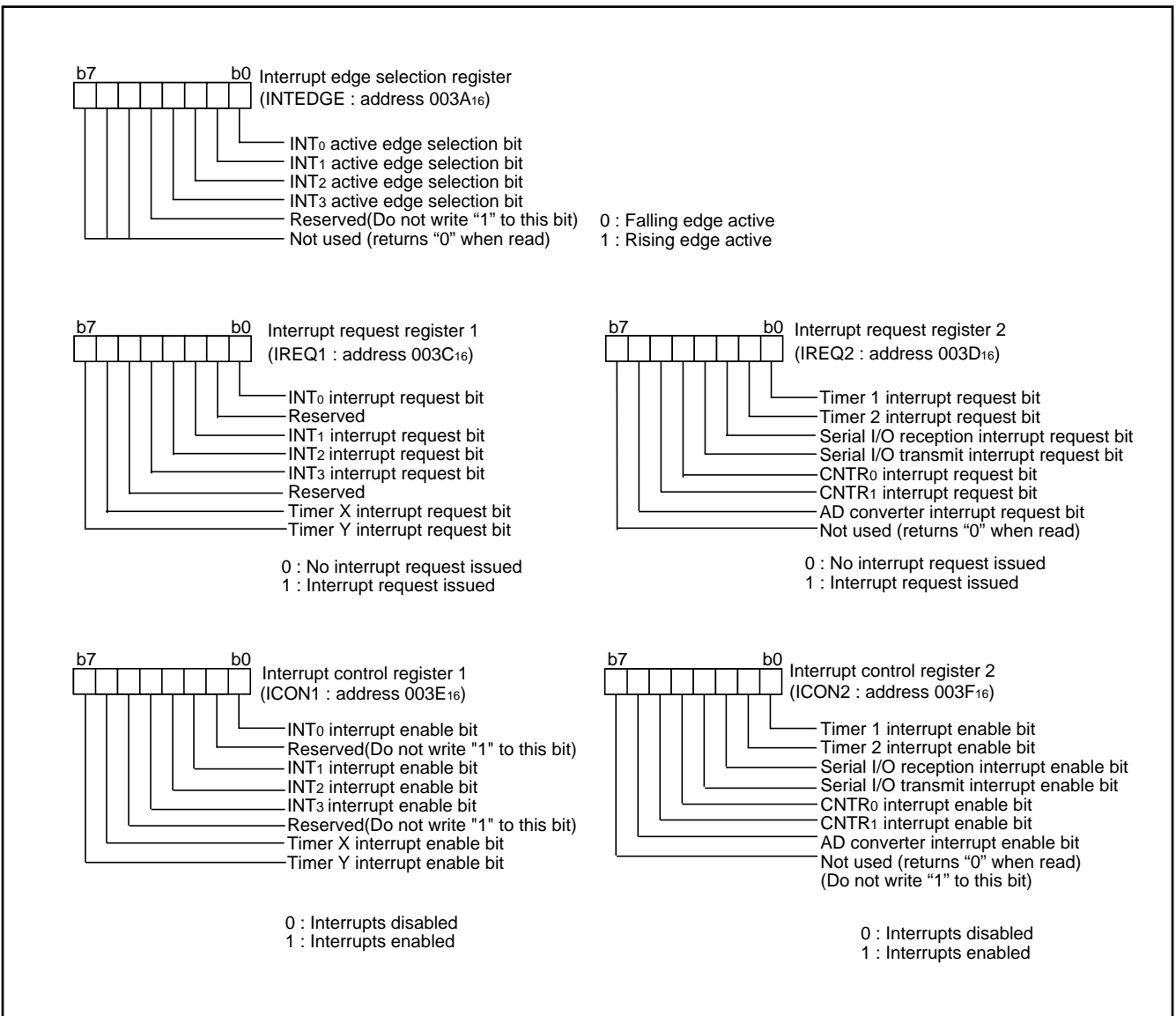

Fig. 11 Structure of interrupt-related registers (1)

TIMERS

The 3850 group has four timers: timer X, timer Y, timer 1, and timer 2.

The division ratio of each timer or prescaler is given by $1/(n + 1)$, where n is the value in the corresponding timer or prescaler latch. All timers are count down. When the timer reaches "0016", an underflow occurs at the next count pulse and the corresponding timer latch is reloaded into the timer and the count is continued. When a timer underflows, the interrupt request bit corresponding to that timer is set to "1".

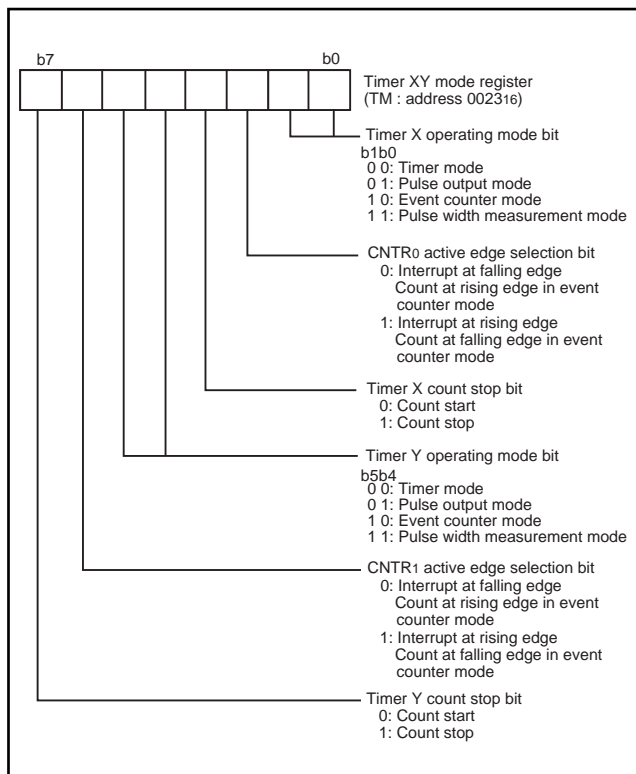

Fig. 12 Structure of timer XY mode register

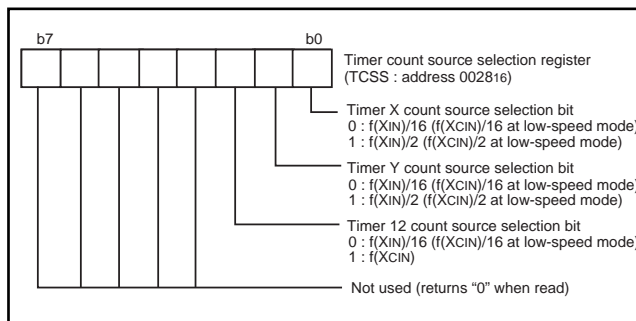

Fig. 13 Structure of timer count source selection register

Timer 1 and Timer 2

The count source of prescaler 12 is the oscillation frequency which is selected by timer 12 count source selection bit. The output of prescaler 12 is counted by timer 1 and timer 2, and a timer underflow sets the interrupt request bit.

Timer X and Timer Y

Timer X and Timer Y can each select in one of four operating modes by setting the timer XY mode register.

(1) Timer Mode

The timer counts the count source selected by Timer count source selection bit.

(2) Pulse Output Mode

The timer counts the count source selected by Timer count source selection bit. Whenever the contents of the timer reach "0016", the signal output from the CNTR0 (or CNTR1) pin is inverted. If the CNTR0 (or CNTR1) active edge selection bit is "0", output begins at "H".

If it is "1", output starts at "L". When using a timer in this mode, set the corresponding port P27 (or port P40) direction register to output mode.

(3) Event Counter Mode

Operation in event counter mode is the same as in timer mode, except that the timer counts signals input through the CNTR0 or CNTR1 pin.

When the CNTR0 (or CNTR1) active edge selection bit is "0", the rising edge of the CNTR0 (or CNTR1) pin is counted.

When the CNTR0 (or CNTR1) active edge selection bit is "1", the falling edge of the CNTR0 (or CNTR1) pin is counted.

(4) Pulse Width Measurement Mode

If the CNTR0 (or CNTR1) active edge selection bit is "0", the timer counts the selected signals by the count source selection bit while the CNTR0 (or CNTR1) pin is at "H". If the CNTR0 (or CNTR1) active edge selection bit is "1", the timer counts it while the CNTR0 (or CNTR1) pin is at "L".

The count can be stopped by setting "1" to the timer X (or timer Y) count stop bit in any mode. The corresponding interrupt request bit is set each time a timer underflows.

■Note

When switching the count source by the timer 12, X and Y count source bit, the value of timer count is altered in unconsiderable amount owing to generating of a thin pulses in the count input signals.

Therefore, select the timer count source before set the value to the prescaler and the timer.

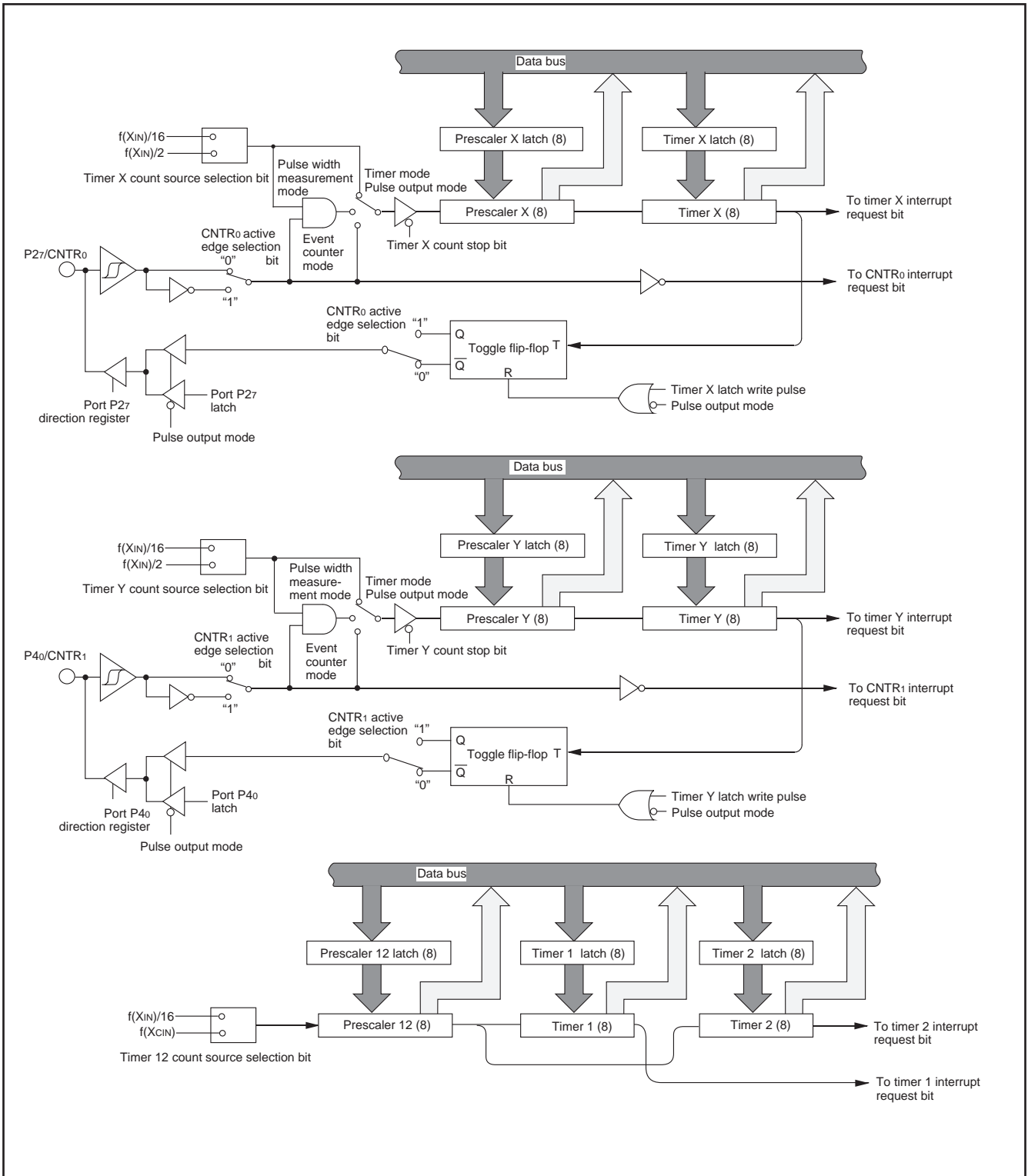

Fig. 14 Block diagram of timer X, timer Y, timer 1, and timer 2

SERIAL I/O

Serial I/O can be used as either clock synchronous or asynchronous (UART) serial I/O. A dedicated timer is also provided for baud rate generation.

(1) Clock Synchronous Serial I/O Mode

Clock synchronous serial I/O mode can be selected by setting the serial I/O mode selection bit of the serial I/O control register (bit 6 of address 001A₁₆) to "1".

For clock synchronous serial I/O, the transmitter and the receiver must use the same clock. If an internal clock is used, transfer is started by a write signal to the TB/RB.

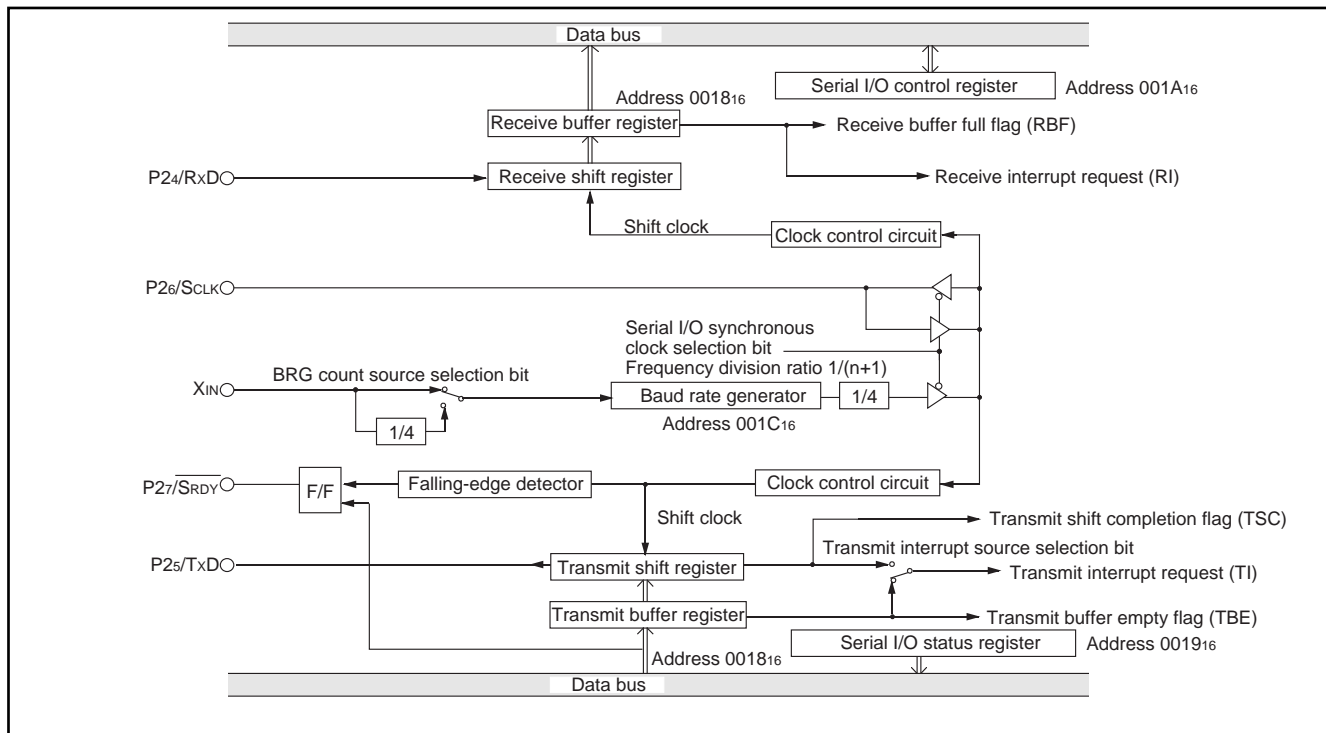

Fig. 15 Block diagram of clock synchronous serial I/O

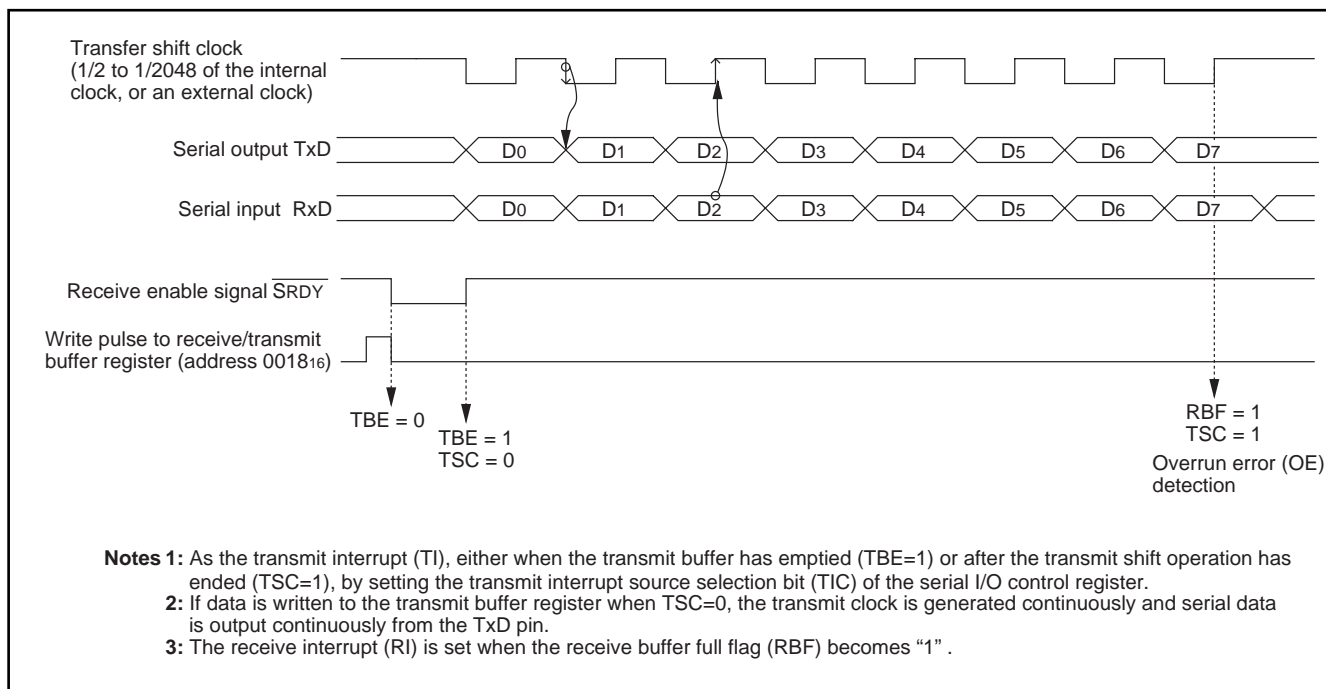

Fig. 16 Operation of clock synchronous serial I/O function

(2) Asynchronous Serial I/O (UART) Mode

Clock asynchronous serial I/O mode (UART) can be selected by clearing the serial I/O mode selection bit (b6) of the serial I/O control register to "0".

Eight serial data transfer formats can be selected, and the transfer formats used by a transmitter and receiver must be identical.

The transmit and receive shift registers each have a buffer, but the

two buffers have the same address in memory. Since the shift register cannot be written to or read from directly, transmit data is written to the transmit buffer register, and receive data is read from the receive buffer register.

The transmit buffer register can also hold the next data to be transmitted, and the receive buffer register can hold a character while the next character is being received.

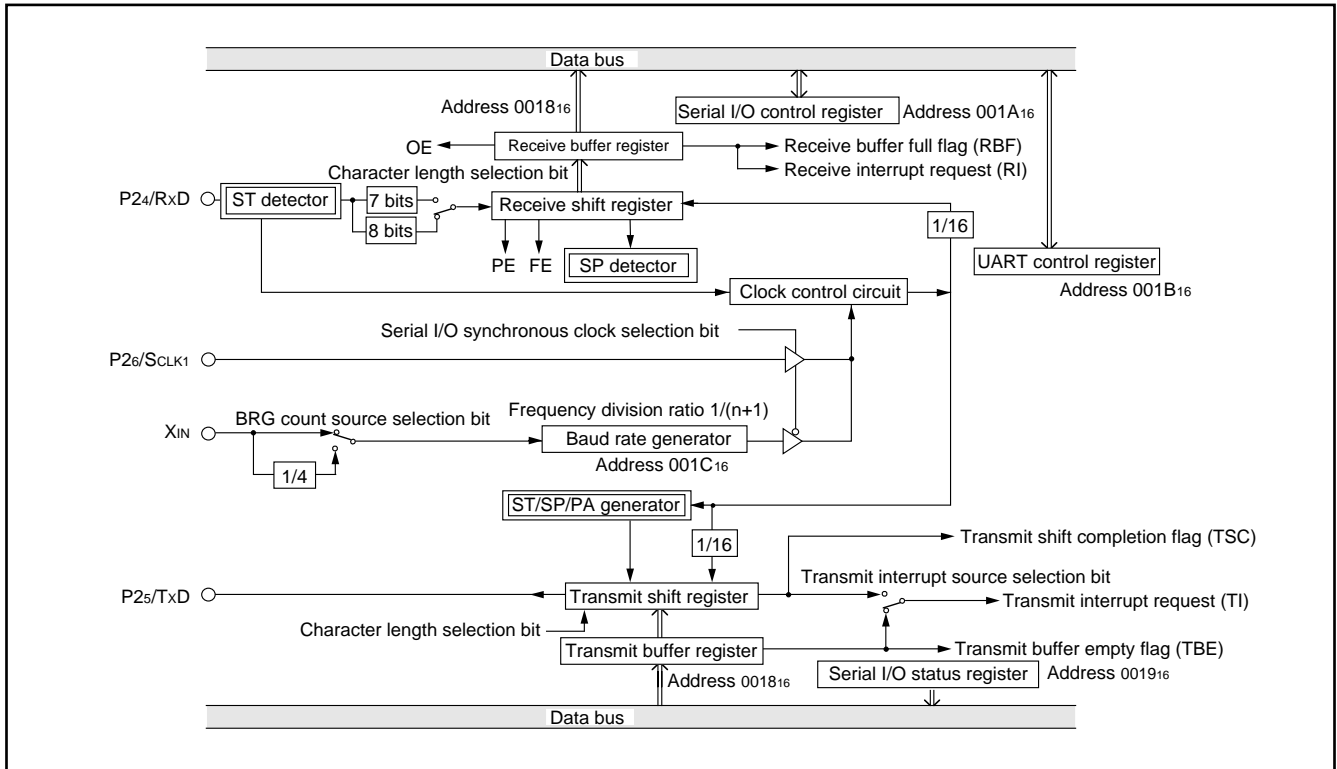

Fig.17 Block diagram of UART serial I/O

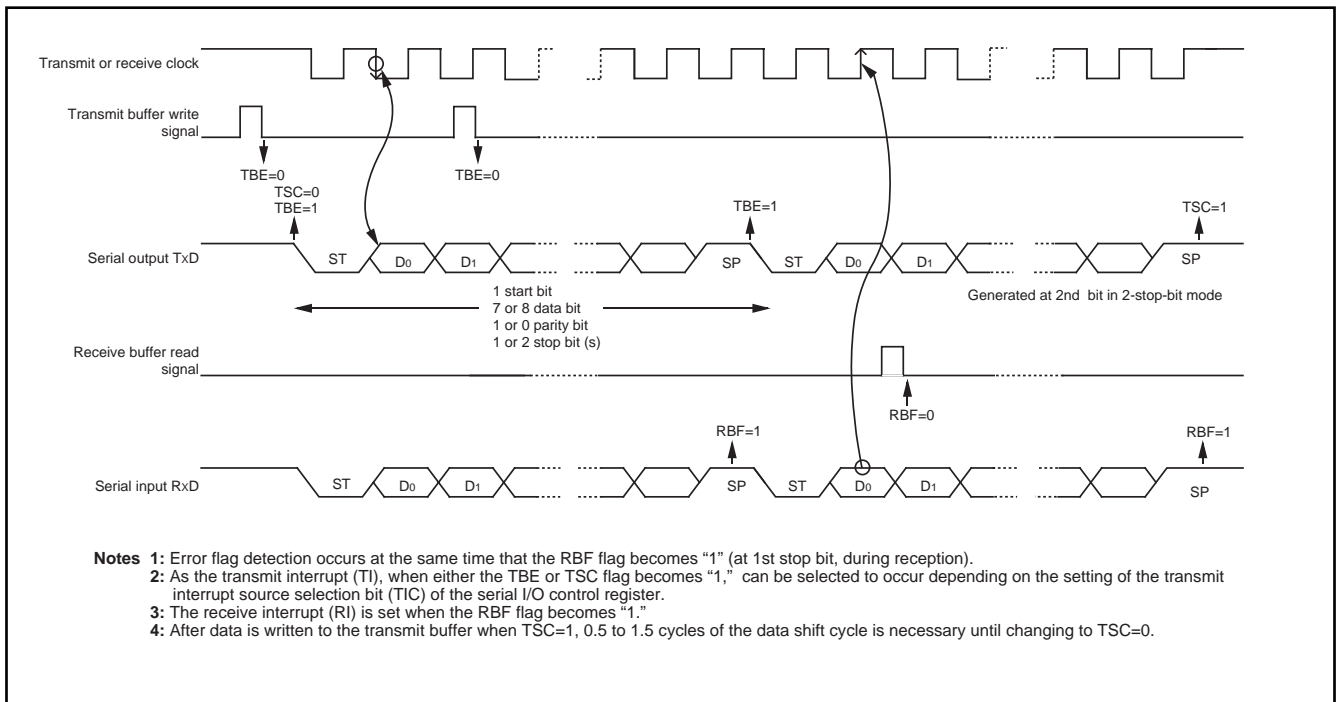

Fig. 18 Operation of UART serial I/O function

[Transmit Buffer Register/Receive Buffer Register (TB/RB)] 001816

The transmit buffer register and the receive buffer register are located at the same address. The transmit buffer is write-only and the receive buffer is read-only. If a character bit length is 7 bits, the MSB of data stored in the receive buffer is "0".

[Serial I/O Status Register (SIOSTS)] 001916

The read-only serial I/O status register consists of seven flags (bits 0 to 6) which indicate the operating status of the serial I/O function and various errors.

Three of the flags (bits 4 to 6) are valid only in UART mode.

The receive buffer full flag (bit 1) is cleared to "0" when the receive buffer register is read.

If there is an error, it is detected at the same time that data is transferred from the receive shift register to the receive buffer register, and the receive buffer full flag is set. A write to the serial I/O status register clears all the error flags OE, PE, FE, and SE (bit 3 to bit 6, respectively). Writing "0" to the serial I/O enable bit SIOE (bit 7 of the serial I/O control register) also clears all the status flags, including the error flags.

Bits 0 to 6 of the serial I/O status register are initialized to "0" at reset, but if the transmit enable bit (bit 4) of the serial I/O control register has been set to "1", the transmit shift completion flag (bit 2) and the transmit buffer empty flag (bit 0) become "1".

Serial I/O Control Register (SIOCON)] 001A16

The serial I/O control register consists of eight control bits for the serial I/O function.

[UART Control Register (UARTCON)] 001B16

The UART control register consists of four control bits (bits 0 to 3) which are valid when asynchronous serial I/O is selected and set the data format of an data transfer and one bit (bit 4) which is always valid and sets the output structure of the P25/TxD pin.

[Baud Rate Generator (BRG)] 001C16

The baud rate generator determines the baud rate for serial transfer.

The baud rate generator divides the frequency of the count source by $1/(n + 1)$, where n is the value written to the baud rate generator.

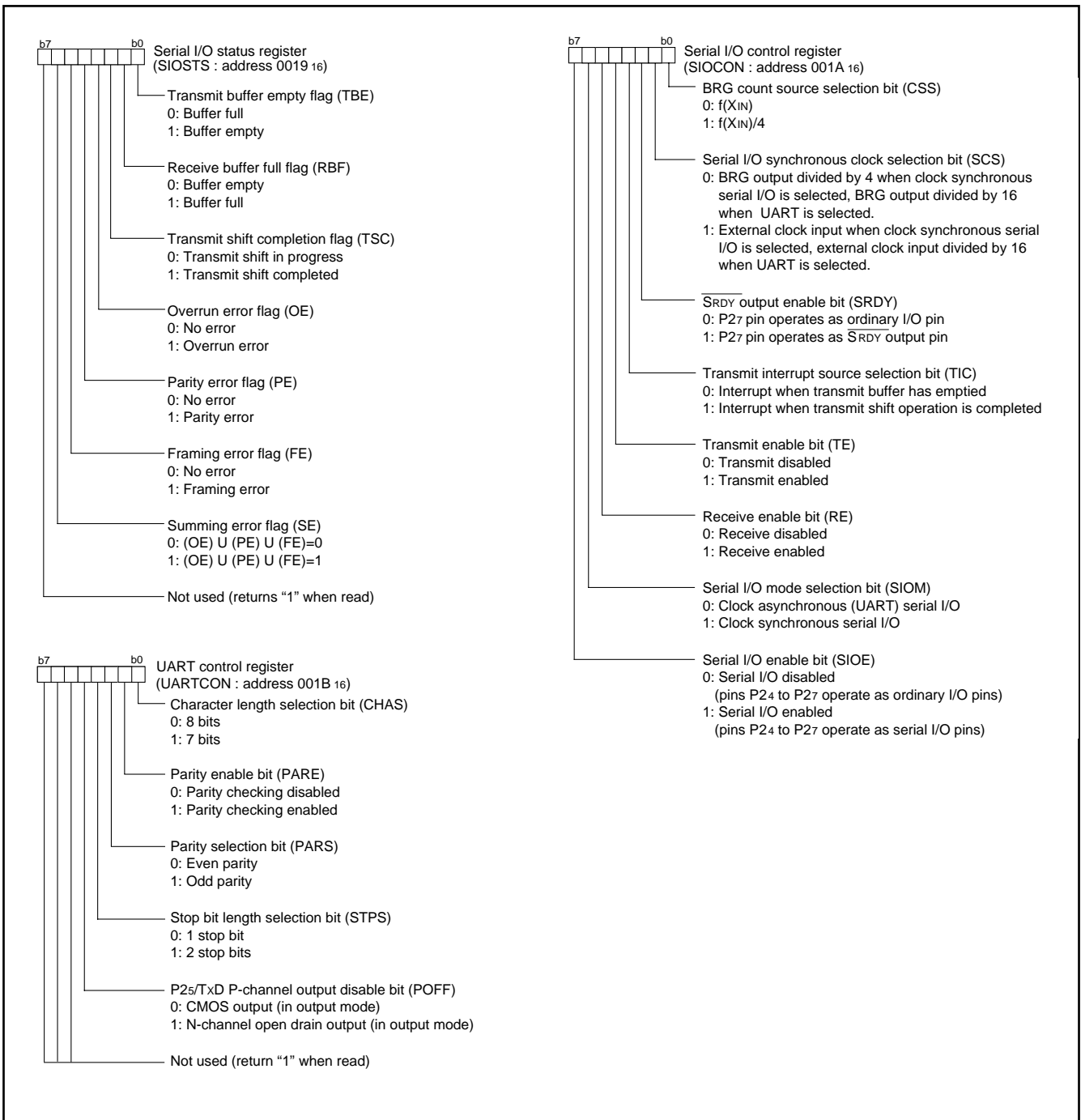

Fig. 19 Structure of serial I/O control registers

PULSE WIDTH MODULATION (PWM)

The 3850 group has a PWM function with an 8-bit resolution, based on a signal that is the clock input X_{IN} or that clock input divided by 2.

Data Setting

The PWM output pin also functions as port P44. Set the PWM period by the PWM prescaler, and set the "H" term of output pulse by the PWM register.

If the value in the PWM prescaler is n and the value in the PWM register is m (where n = 0 to 255 and m = 0 to 255) :

$$\begin{aligned} \text{PWM period} &= 255 \times (n+1) / f(X_{IN}) \\ &= 31.875 \times (n+1) \mu\text{s} \quad (\text{when } f(X_{IN}) = 8 \text{ MHz}) \end{aligned}$$

$$\text{Output pulse "H" term} = \text{PWM period} \times m / 255$$

$$\begin{aligned} &= 0.125 \times (n+1) \times m \mu\text{s} \\ &\quad (\text{when } f(X_{IN}) = 8 \text{ MHz}) \end{aligned}$$

PWM Operation

When bit 0 (PWM enable bit) of the PWM control register is set to "1", operation starts by initializing the PWM output circuit, and pulses are output starting at an "H".

If the PWM register or PWM prescaler is updated during PWM output, the pulses will change in the cycle after the one in which the change was made.

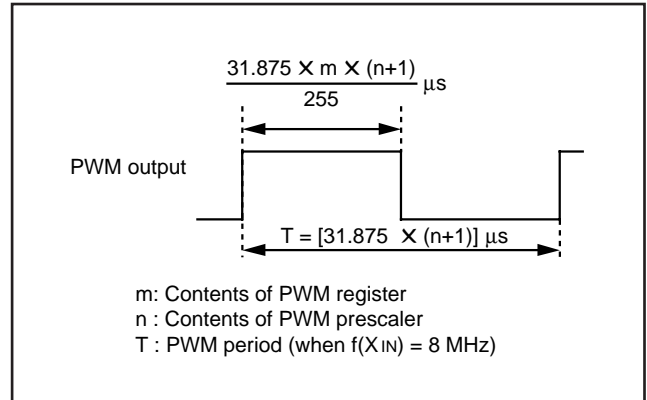

Fig. 20 Timing of PWM period

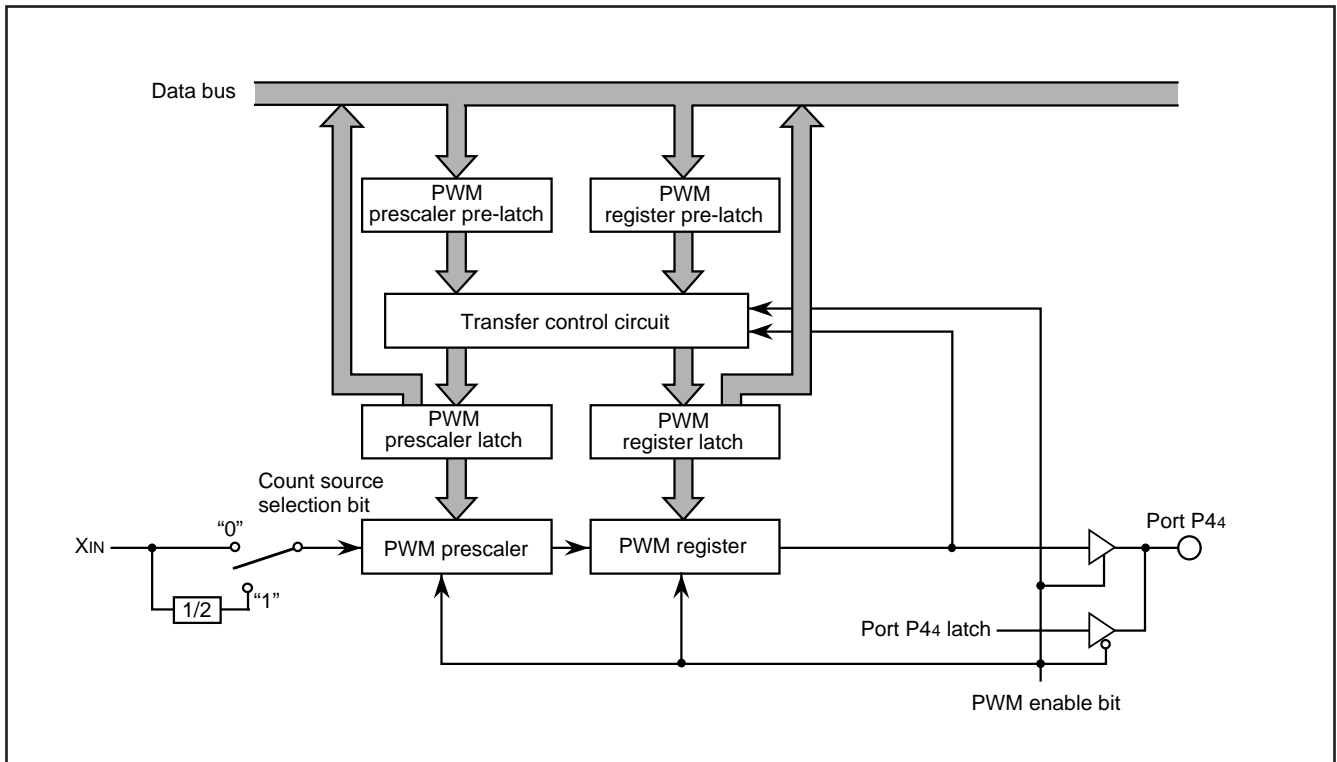

Fig. 21 Block diagram of PWM function

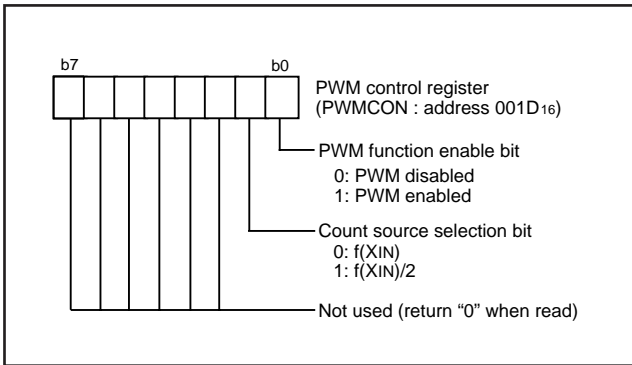

Fig. 22 Structure of PWM control register

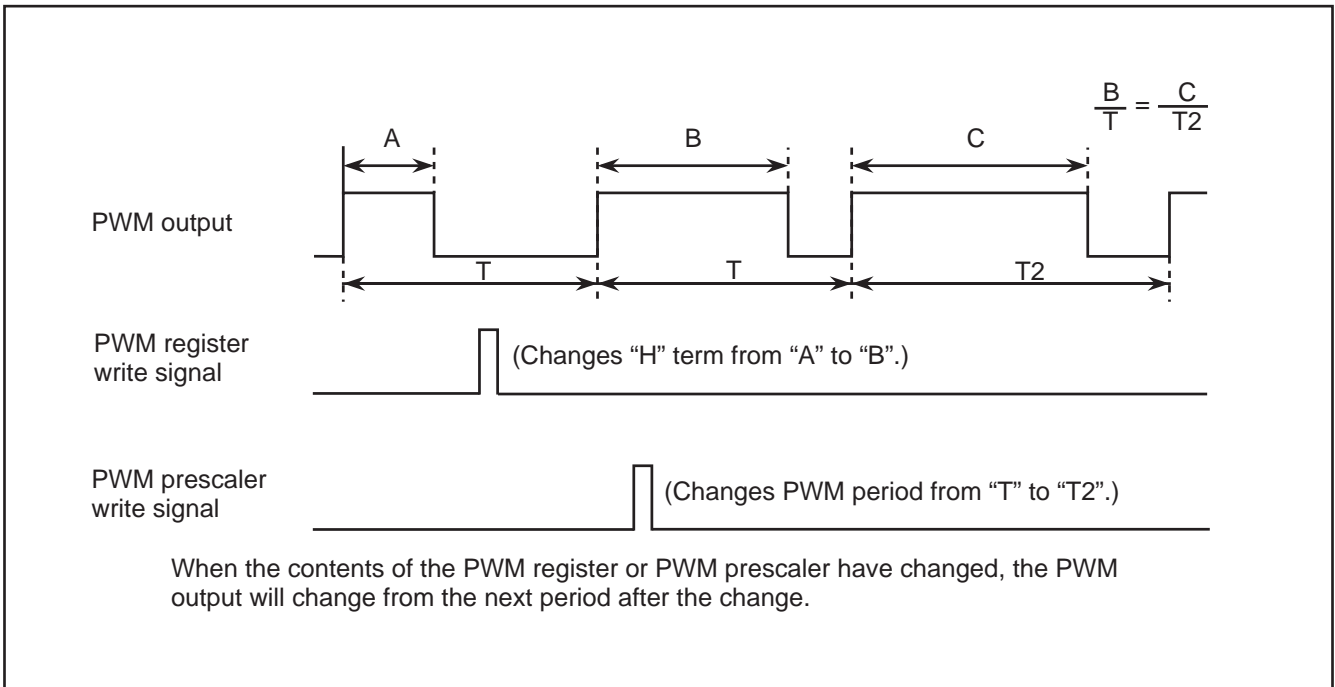

Fig. 23 PWM output timing when PWM register or PWM prescaler is changed

■Note

The PWM starts after the PWM enable bit is set to enable and "L" level is output from the PWM pin. The length of this "L" level output is as follows:

$$\frac{n+1}{2 \cdot f(XIN)} \text{ sec} \quad (\text{Count source selection bit} = 0, \text{ where } n \text{ is the value set in the prescaler})$$

$$\frac{n+1}{f(XIN)} \text{ sec} \quad (\text{Count source selection bit} = 1, \text{ where } n \text{ is the value set in the prescaler})$$

A-D CONVERTER

[A-D Conversion Registers (ADL, ADH)] 003516, 003616

The A-D conversion registers are read-only registers that store the result of an A-D conversion. Do not read these registers during an A-D conversion

[AD Control Register (ADCON)] 003416

The AD control register controls the A-D conversion process. Bits 0 to 2 select a specific analog input pin. Bit 4 indicates the completion of an A-D conversion. The value of this bit remains at "0" during an A-D conversion and changes to "1" when an A-D conversion ends. Writing "0" to this bit starts the A-D conversion.

Comparison Voltage Generator

The comparison voltage generator divides the voltage between AVSS and VREF into 1024 and outputs the divided voltages.

Channel Selector

The channel selector selects one of ports P30/AN0 to P34/AN4 and inputs the voltage to the comparator.

Comparator and Control Circuit

The comparator and control circuit compare an analog input voltage with the comparison voltage, and the result is stored in the A-D conversion registers. When an A-D conversion is completed, the control circuit sets the A-D conversion completion bit and the A-D interrupt request bit to "1".

Note that because the comparator consists of a capacitor coupling, set f(XIN) to 500 kHz or more during an A-D conversion.

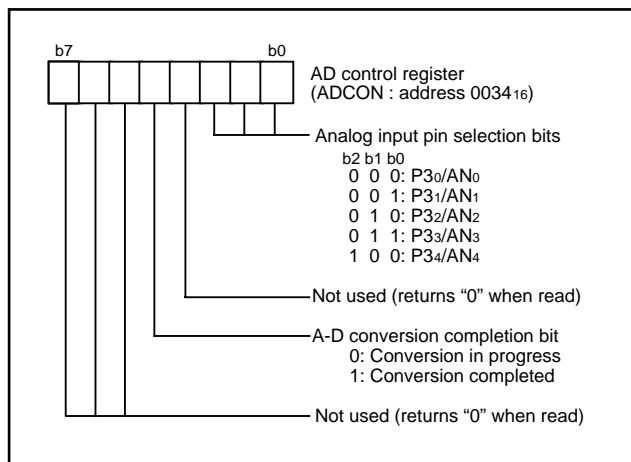

Fig. 24 Structure of AD control register

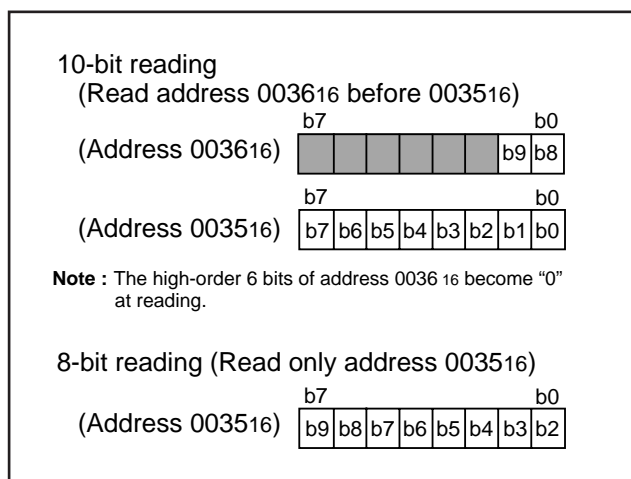

Fig. 25 Structure of A-D conversion registers

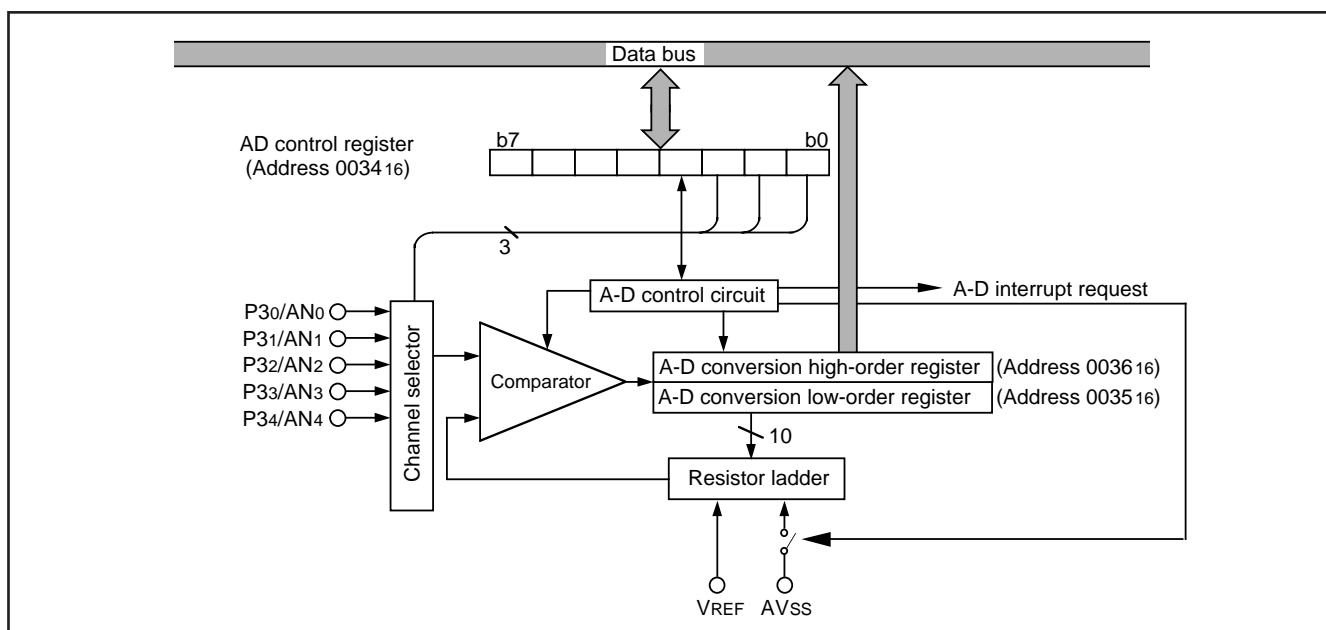

Fig. 26 Block diagram of A-D converter

WATCHDOG TIMER

The watchdog timer gives a mean of returning to the reset status when a program cannot run on a normal loop (for example, because of a software run-away). The watchdog timer consists of an 8-bit watchdog timer L and an 8-bit watchdog timer H.

Standard Operation of Watchdog Timer

When any data is not written into the watchdog timer control register (address 0039₁₆) after resetting, the watchdog timer is in the stop state. The watchdog timer starts to count down by writing an optional value into the watchdog timer control register (address 0039₁₆) and an internal reset occurs at an underflow of the watchdog timer H.

Accordingly, programming is usually performed so that writing to the watchdog timer control register (address 0039₁₆) may be started before an underflow. When the watchdog timer control register (address 0039₁₆) is read, the values of the high-order 6 bits of the watchdog timer H, STP instruction disable bit, and watchdog timer H count source selection bit are read.

Initial value of watchdog timer

At reset or writing to the watchdog timer control register (address 0039₁₆), each watchdog timer H and L is set to "FF₁₆."

Watchdog timer H count source selection bit operation

Bit 7 of the watchdog timer control register (address 0039₁₆) permits selecting a watchdog timer H count source. When this bit is set to "0", the count source becomes the underflow signal of watchdog timer L. The detection time is set to 131.072 ms at $f(X_{IN}) = 8$ MHz frequency and 32.768 s at $f(X_{CIN}) = 32$ kHz frequency. When this bit is set to "1", the count source becomes the signal divided by 16 for $f(X_{IN})$ (or $f(X_{CIN})$). The detection time in this case is set to 512 μ s at $f(X_{IN}) = 8$ MHz frequency and 128 ms at $f(X_{CIN}) = 32$ kHz frequency. This bit is cleared to "0" after resetting.

Operation of STP instruction disable bit

Bit 6 of the watchdog timer control register (address 0039₁₆) permits disabling the STP instruction when the watchdog timer is in operation.

When this bit is "0", the STP instruction is enabled.

When this bit is "1", the STP instruction is disabled, once the STP instruction is executed, an internal reset occurs. When this bit is set to "1", it cannot be rewritten to "0" by program. This bit is cleared to "0" after resetting.

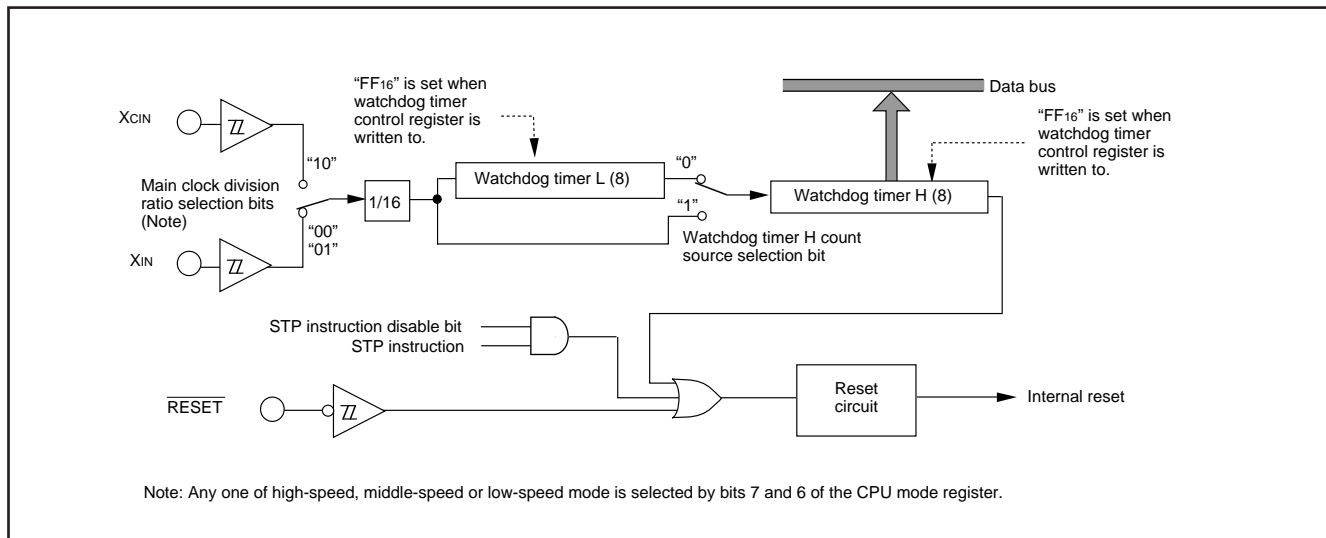

Fig. 27 Block diagram of Watchdog timer

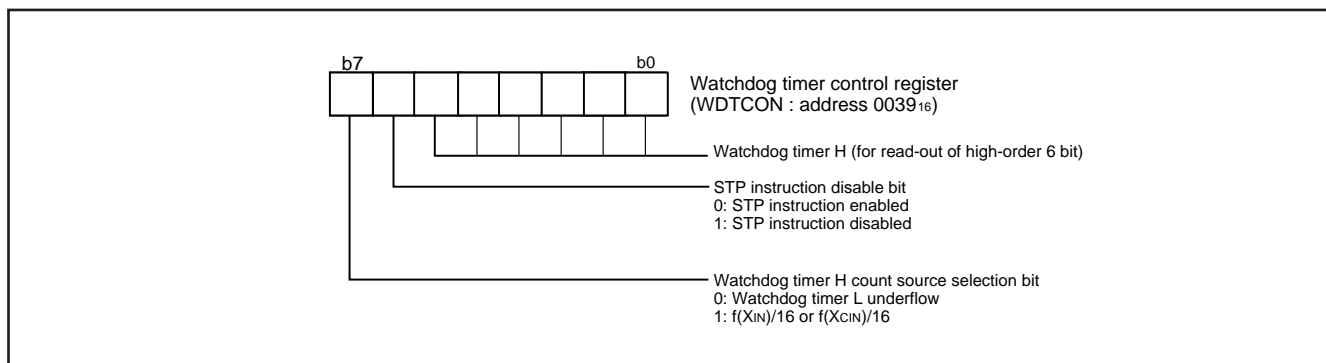

Fig. 28 Structure of Watchdog timer control register

RESET CIRCUIT

To reset the microcomputer, $\overline{\text{RESET}}$ pin must be held at an "L" level for 2 μs or more. Then the $\overline{\text{RESET}}$ pin is returned to an "H" level (the power source voltage must be between 2.7 V and 5.5 V, and the oscillation must be stable), reset is released. After the reset is completed, the program starts from the address contained in address FFFD_{16} (high-order byte) and address FFFC_{16} (low-order byte). Make sure that the reset input voltage is less than 0.54 V for V_{CC} of 2.7 V.

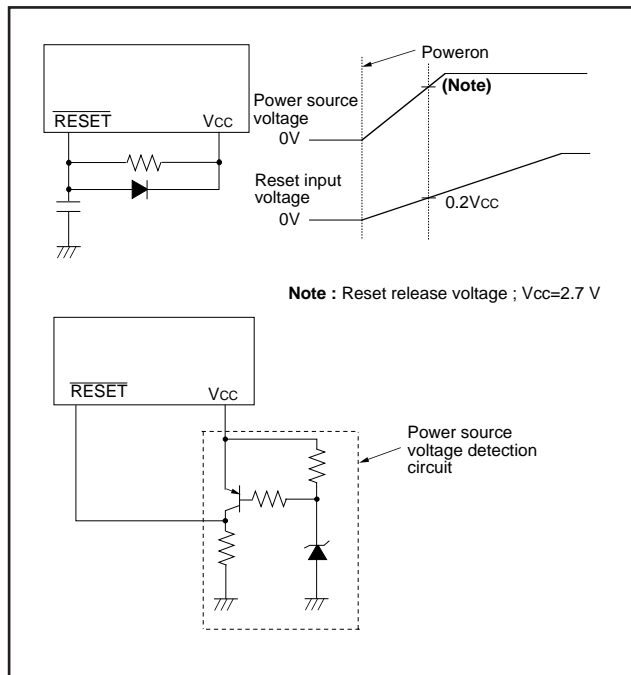

Fig. 29 Reset circuit example

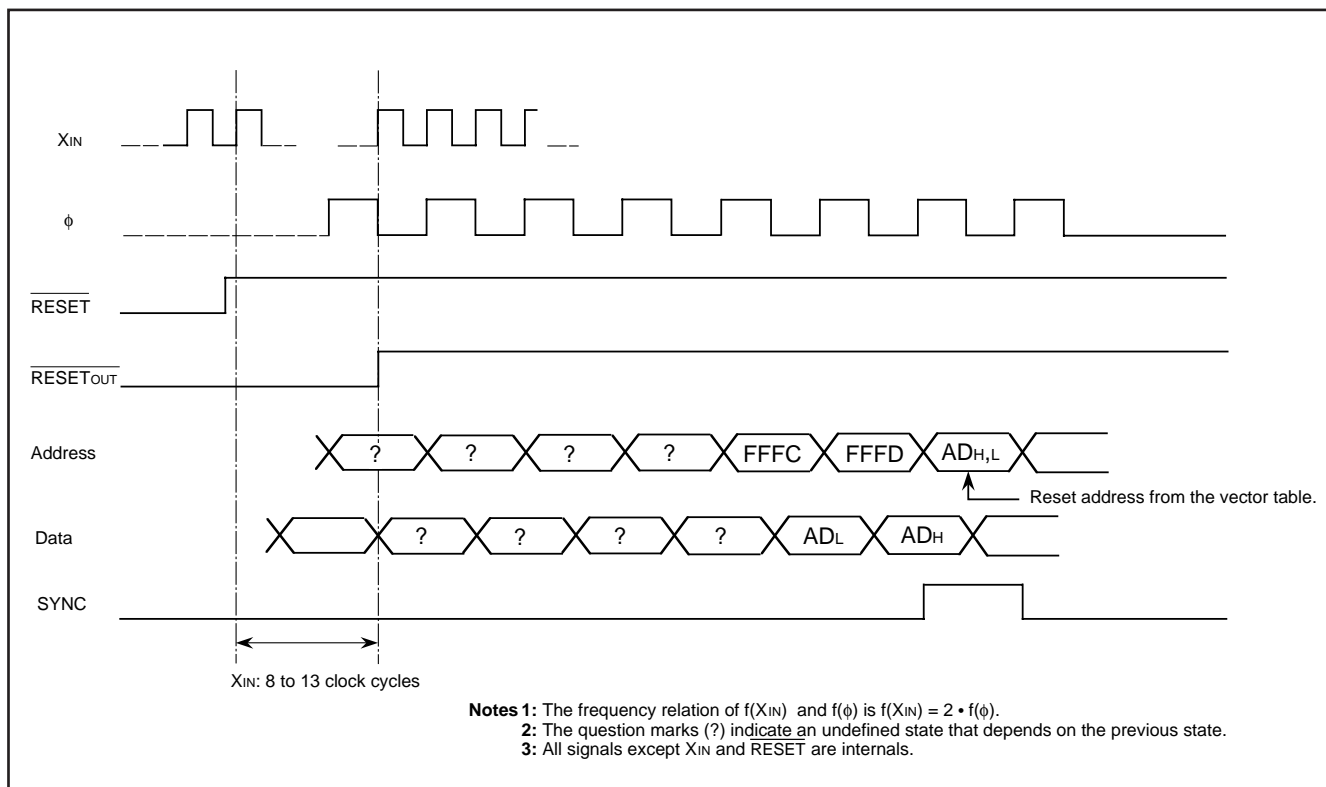

Fig. 30 Reset sequence

	Address	Register contents
(1) Port P0 direction register (P0D)	0001 ₁₆	00 ₁₆
(2) Port P1 direction register (P1D)	0003 ₁₆	00 ₁₆
(3) Port P2 direction register (P2D)	0005 ₁₆	00 ₁₆
(4) Port P3 direction register (P3D)	0007 ₁₆	00 ₁₆
(5) Port P4 direction register (P4D)	0009 ₁₆	00 ₁₆
(6) Serial I/O status register (SIOSTS)	0019 ₁₆	1 0 0 0 0 0 0 0 0 0
(7) Serial I/O control register (SIOCON)	001A ₁₆	00 ₁₆
(8) UART control register (UARTCON)	001B ₁₆	1 1 1 0 0 0 0 0 0 0
(9) PWM control register (PWMCON)	001D ₁₆	00 ₁₆
(10) Prescaler 12 (PRE12)	0020 ₁₆	FF ₁₆
(11) Timer 1 (T1)	0021 ₁₆	01 ₁₆
(12) Timer 2 (T2)	0022 ₁₆	00 ₁₆
(13) Timer XY mode register (TM)	0023 ₁₆	00 ₁₆
(14) Prescaler X (PREX)	0024 ₁₆	FF ₁₆
(15) Timer X (TX)	0025 ₁₆	FF ₁₆
(16) Prescaler Y (PREY)	0026 ₁₆	FF ₁₆
(17) Timer Y (TY)	0027 ₁₆	FF ₁₆
(18) Timer count source select register	0028 ₁₆	00 ₁₆
(19) Reserved	002C ₁₆	Not fixed
(20) Reserved	002D ₁₆	Not fixed
(21) Reserved	002E ₁₆	Not fixed
(22) Reserved	002F ₁₆	Not fixed
(23) Reserved	0030 ₁₆	Not fixed
(24) AD control register (ADCON)	0034 ₁₆	0 0 0 1 0 0 0 0 0 0
(25) MISRG	0038 ₁₆	00 ₁₆
(26) Watchdog timer control register (WDTCON)	0039 ₁₆	0 0 1 1 1 1 1 1 1 1
(27) Interrupt edge selection register (INTEEDGE)	003A ₁₆	00 ₁₆
(28) CPU mode register (CPUM)	003B ₁₆	0 1 0 0 1 0 0 0 0 0
(29) Interrupt request register 1 (IREQ1)	003C ₁₆	00 ₁₆
(30) Interrupt request register 2 (IREQ2)	003D ₁₆	00 ₁₆
(31) Interrupt control register 1 (ICON1)	003E ₁₆	00 ₁₆
(32) Interrupt control register 2 (ICON2)	003F ₁₆	00 ₁₆
(33) Processor status register	(PS)	X X X X X 1 X X
(34) Program counter	(PC _H)	FFF ₁₆ contents
	(PC _L)	FFC ₁₆ contents

Note : X indicates Not fixed .

Fig. 31 Internal status at reset

CLOCK GENERATING CIRCUIT

The 3850 group has two built-in oscillation circuits. An oscillation circuit can be formed by connecting a resonator between X_{IN} and X_{OUT} (X_{CIN} and X_{COU}T). Use the circuit constants in accordance with the resonator manufacturer's recommended values. No external resistor is needed between X_{IN} and X_{OUT} since a feed-back resistor exists on-chip. However, an external feed-back resistor is needed between X_{CIN} and X_{COU}T.

Immediately after power on, only the X_{IN} oscillation circuit starts oscillating, and X_{CIN} and X_{COU}T pins function as I/O ports.

Frequency Control

(1) Middle-speed mode

The internal clock ϕ is the frequency of X_{IN} divided by 8. After reset, this mode is selected.

(2) High-speed mode

The internal clock ϕ is half the frequency of X_{IN}.

(3) Low-speed mode

The internal clock ϕ is half the frequency of X_{CIN}.

■Note

If you switch the mode between middle/high-speed and low-speed, stabilize both X_{IN} and X_{CIN} oscillations. The sufficient time is required for the sub-clock to stabilize, especially immediately after power on and at returning from the stop mode. When switching the mode between middle/high-speed and low-speed, set the frequency on condition that $f(X_{IN}) > 3 \cdot f(X_{CIN})$.

(4) Low power dissipation mode

The low power consumption operation can be realized by stopping the main clock X_{IN} in low-speed mode. To stop the main clock, set bit 5 of the CPU mode register to "1." When the main clock X_{IN} is restarted (by setting the main clock stop bit to "0"), set sufficient time for oscillation to stabilize.

The sub-clock X_{CIN}-X_{COU}T oscillating circuit can not directly input clocks that are generated externally. Accordingly, make sure to cause an external resonator to oscillate.

Oscillation Control

(1) Stop mode

If the STP instruction is executed, the internal clock ϕ stops at an "H" level, and X_{IN} and X_{CIN} oscillation stops. When the oscillation stabilizing time set after STP instruction released bit is "0," the prescaler 12 is set to "FF₁₆" and timer 1 is set to "01₁₆." When the oscillation stabilizing time set after STP instruction released bit is "1," set the sufficient time for oscillation of used oscillator to stabilize since nothing is set to the prescaler 12 and timer 1.

Either X_{IN} or X_{CIN} divided by 16 is input to the prescaler 12 as count source. Oscillator restarts when an external interrupt is received, but the internal clock ϕ is not supplied to the CPU (remains at "H") until timer 1 underflows. The internal clock ϕ is supplied for the first time, when timer 1 underflows. This ensures time for the clock oscillation using the ceramic resonators to be stabilized. When the oscillator is restarted by reset, apply "L" level to the RESET pin until the oscillation is stable since a wait time will not

be generated.

(2) Wait mode

If the WIT instruction is executed, the internal clock ϕ stops at an "H" level, but the oscillator does not stop. The internal clock ϕ restarts at reset or when an interrupt is received. Since the oscillator does not stop, normal operation can be started immediately after the clock is restarted.

To ensure that the interrupts will be received to release the STP or WIT state, their interrupt enable bits must be set to "1" before executing of the STP or WIT instruction.

When releasing the STP state, the prescaler 12 and timer 1 will start counting the clock X_{IN} divided by 16. Accordingly, set the timer 1 interrupt enable bit to "0" before executing the STP instruction.

■Note

When using the oscillation stabilizing time set after STP instruction released bit set to "1", evaluate time to stabilize oscillation of the used oscillator and set the value to the timer 1 and prescaler 12.

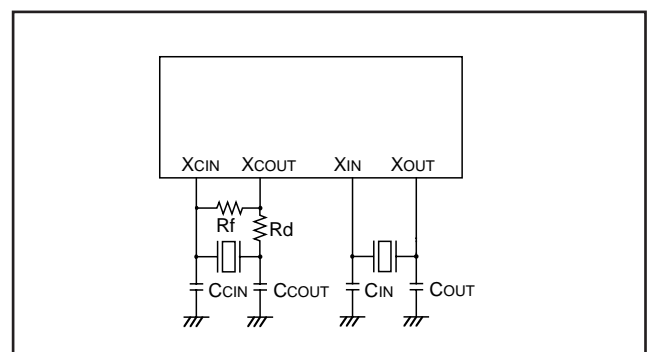

Fig. 32 Ceramic resonator circuit

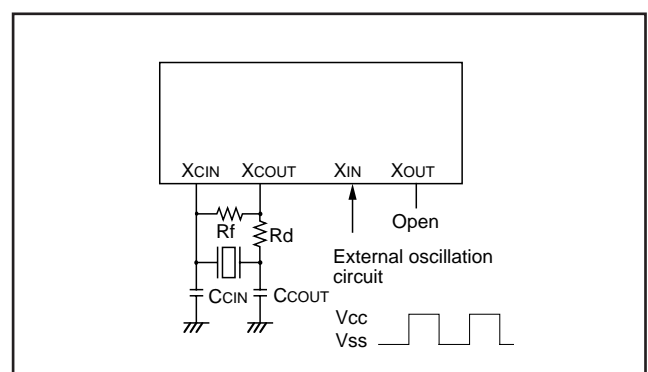

Fig. 33 External clock input circuit

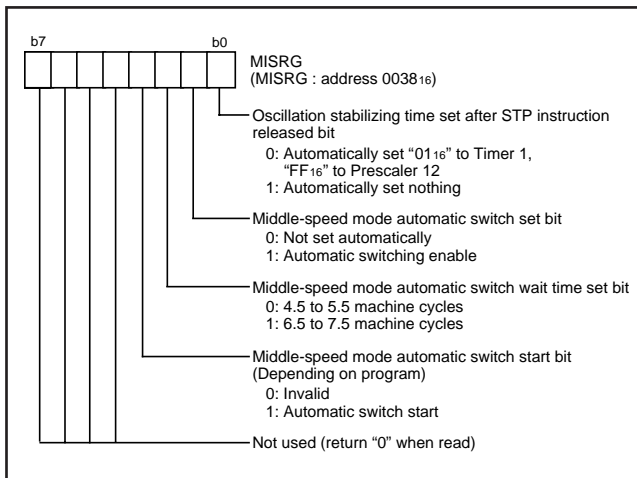

Fig. 34 Structure of MISRG

Middle-speed mode automatic switch set bit

By setting the middle-speed mode automatic switch set bit to "1" while operating in the low-speed mode, XIN oscillation automatically starts and the mode is automatically switched to the middle-speed mode when detecting a rising/falling edge of the SCL or SDA pin. The middle-speed automatic switch wait time set bit can select the switch timing from the low-speed to the middle-speed mode; either 4.5 to 5.5 machine cycles or 6.5 to 7.5 machine cycles in the low-speed mode. Select it according to oscillation start characteristics of used XIN oscillator.

The middle-speed mode automatic switch start bit is used to automatically make to XIN oscillation start and switch to the middle-speed mode by setting this bit to "1" while operating in the low-speed mode.

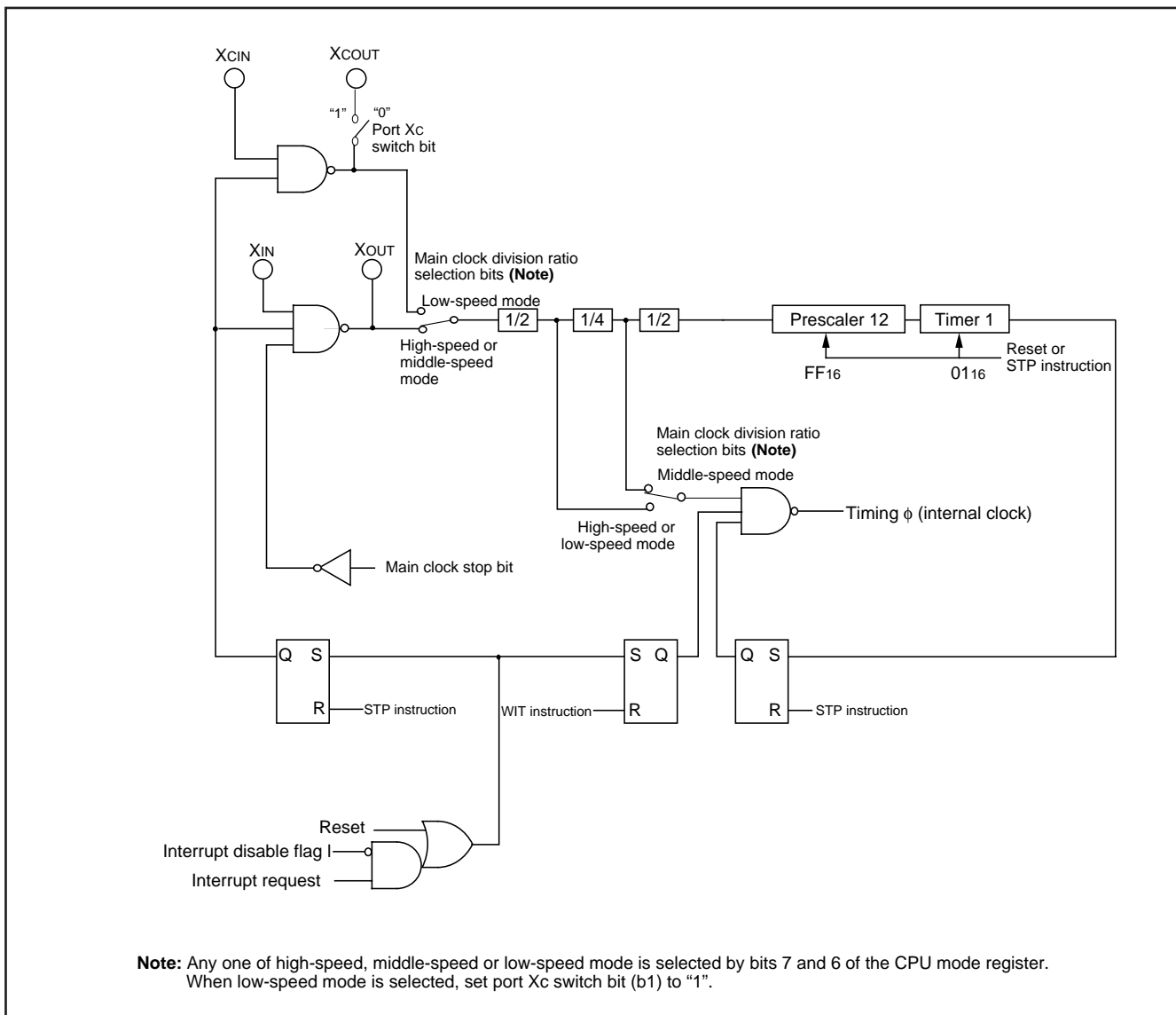

Fig. 35 System clock generating circuit block diagram (Single-chip mode)

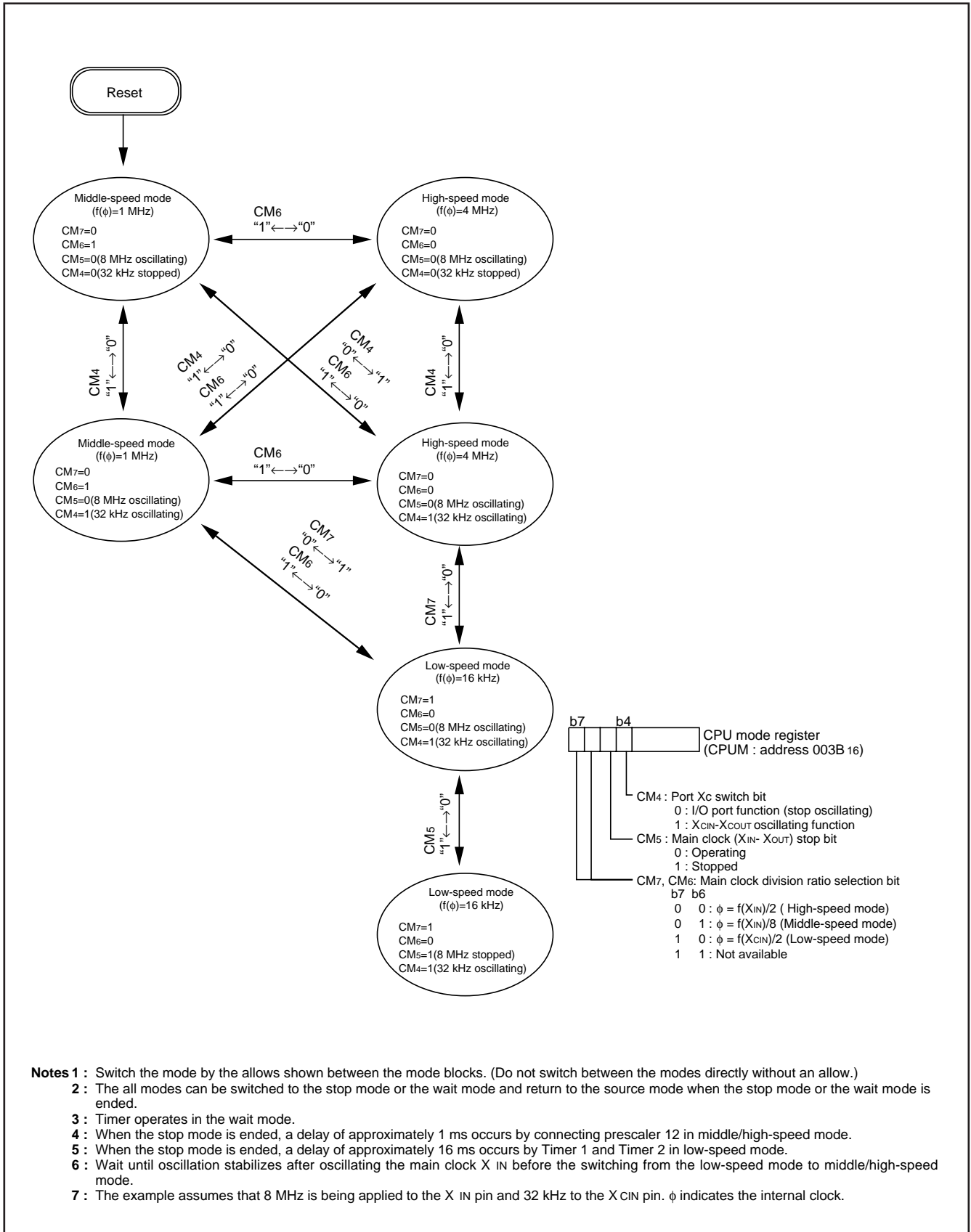

Fig. 36 State transitions of system clock

NOTES ON PROGRAMMING

Processor Status Register

The contents of the processor status register (PS) after a reset are undefined, except for the interrupt disable flag (I) which is "1." After a reset, initialize flags which affect program execution. In particular, it is essential to initialize the index X mode (T) and the decimal mode (D) flags because of their effect on calculations.

Interrupts

The contents of the interrupt request bits do not change immediately after they have been written. After writing to an interrupt request register, execute at least one instruction before performing a BBC or BBS instruction.

Decimal Calculations

- To calculate in decimal notation, set the decimal mode flag (D) to "1", then execute an ADC or SBC instruction. After executing an ADC or SBC instruction, execute at least one instruction before executing a SEC, CLC, or CLD instruction.
- In decimal mode, the values of the negative (N), overflow (V), and zero (Z) flags are invalid.

Timers

If a value n (between 0 and 255) is written to a timer latch, the frequency division ratio is $1/(n+1)$.

Multiplication and Division Instructions

- The index X mode (T) and the decimal mode (D) flags do not affect the MUL and DIV instruction.
- The execution of these instructions does not change the contents of the processor status register.

Ports

The contents of the port direction registers cannot be read. The following cannot be used:

- The data transfer instruction (LDA, etc.)
- The operation instruction when the index X mode flag (T) is "1"
- The addressing mode which uses the value of a direction register as an index
- The bit-test instruction (BBC or BBS, etc.) to a direction register
- The read-modify-write instructions (ROR, CLB, or SEB, etc.) to a direction register.

Use instructions such as LDM and STA, etc., to set the port direction registers.

Serial I/O

In clock synchronous serial I/O, if the receive side is using an external clock and it is to output the SRDY signal, set the transmit enable bit, the receive enable bit, and the SRDY output enable bit to "1."

Serial I/O continues to output the final bit from the TXD pin after transmission is completed.

When an external clock is used as synchronous clock in serial I/O, write transmission data to the transmit buffer register while the transfer clock is "H."

A-D Converter

The comparator uses capacitive coupling amplifier whose charge will be lost if the clock frequency is too low.

Therefore, make sure that $f(XIN)$ is at least on 500 kHz during an A-D conversion.

Do not execute the STP or WIT instruction during an A-D conversion.

Instruction Execution Time

The instruction execution time is obtained by multiplying the frequency of the internal clock ϕ by the number of cycles needed to execute an instruction.

The number of cycles required to execute an instruction is shown in the list of machine instructions.

The frequency of the internal clock ϕ is half of the XIN frequency in high-speed mode.

DATA REQUIRED FOR MASK ORDERS

The following are necessary when ordering a mask ROM production:

- 1.Mask ROM Order Confirmation Form
- 2.Mark Specification Form
- 3.Data to be written to ROM, in EPROM form (three identical copies)

DATA REQUIRED FOR ROM WRITING ORDERS

The following are necessary when ordering a ROM writing:

- 1.ROM Writing Confirmation Form
- 2.Mark Specification Form
- 3.Data to be written to ROM, in EPROM form (three identical copies)

ROM PROGRAMMING METHOD

The built-in PROM of the blank One Time PROM version and built-in EPROM version can be read or programmed with a general-purpose PROM programmer using a special programming adapter. Set the address of PROM programmer in the user ROM area.

Table 5 Programming adapter

Package	Name of Programming Adapter
42P2R-A	PCA4738F-42A
42P4B	PCA4738S-42A

The PROM of the blank One Time PROM version is not tested or screened in the assembly process and following processes. To ensure proper operation after programming, the procedure shown in Figure 49 is recommended to verify programming.

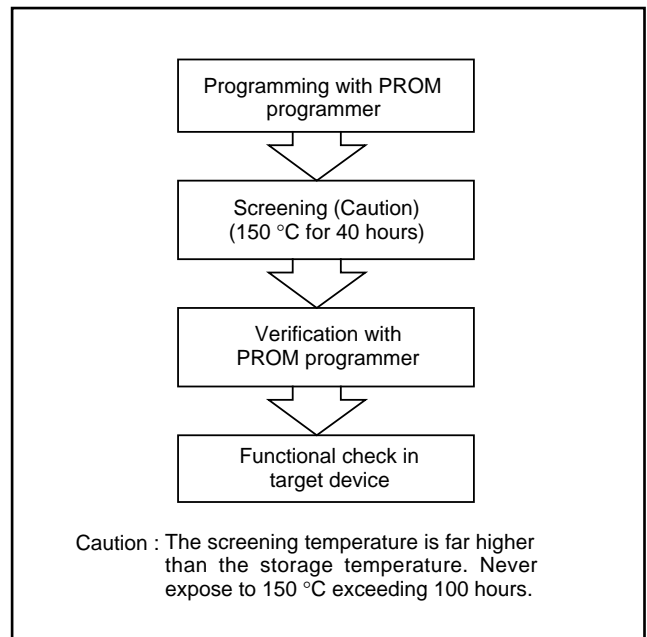

Fig. 37 Programming and testing of One Time PROM version

ELECTRICAL CHARACTERISTICS

Table 6 Absolute maximum ratings

Symbol	Parameter	Conditions	Ratings	Unit
V _{CC}	Power source voltage		-0.3 to 7.0	V
V _I	Input voltage P00-P07, P10-P17, P20, P21, P24-P27, P30-P34, P40-P44, V _{REF}	All voltages are based on V _{SS} . Output transistors are cut off.	-0.3 to V _{CC} +0.3	V
V _I	Input voltage P22, P23		-0.3 to 5.8	V
V _I	Input voltage $\overline{\text{RESET}}$, X _{IN}		-0.3 to V _{CC} +0.3	V
V _I	Input voltage CNV _{SS}		-0.3 to 13	V
V _O	Output voltage P00-P07, P10-P17, P20, P21, P24-P27, P30-P34, P40-P44, X _{OUT}		-0.3 to V _{CC} +0.3	V
V _O	Output voltage P22, P23		-0.3 to 5.8	V
P _d	Power dissipation	T _a = 25 °C	300	mW
T _{opr}	Operating temperature		-20 to 85	°C
T _{stg}	Storage temperature		-40 to 125	°C

Table 7 Recommended operating conditions (1)
(V_{CC} = 2.7 to 5.5 V, T_a = -20 to 85 °C, unless otherwise noted)

Symbol	Parameter	Limits			Unit
		Min.	Typ.	Max.	
V _{CC}	Power source voltage (At 8 MHz)	4.0	5.0	5.5	V
	Power source voltage (At 4 MHz)	2.7	5.0	5.5	
V _{SS}	Power source voltage		0		V
V _{REF}	A-D convert reference voltage	2.0		V _{CC}	V
AV _{SS}	Analog power source voltage		0		V
V _{IA}	Analog input voltage AN0-AN4	AV _{SS}		V _{CC}	V
V _{IH}	"H" input voltage P00-P07, P10-P17, P20-P27, P30-P34, P40-P44	0.8V _{CC}		V _{CC}	V
V _{IH}	"H" input voltage $\overline{\text{RESET}}$, X _{IN} , CNV _{SS}	0.8V _{CC}		V _{CC}	V
V _{IL}	"L" input voltage P00-P07, P10-P17, P20-P27, P30-P34, P40-P44	0		0.2V _{CC}	V
V _{IL}	"L" input voltage $\overline{\text{RESET}}$, CNV _{SS}	0		0.2V _{CC}	V
V _{IL}	"L" input voltage X _{IN}	0		0.16V _{CC}	V
ΣI _{OH(peak)}	"H" total peak output current P00-P07, P10-P17, P30-P34 (Note)			-80	mA
ΣI _{OH(peak)}	"H" total peak output current P20, P21, P24-P27, P40-P44 (Note)			-80	mA
ΣI _{OL(peak)}	"L" total peak output current P00-P07, P10-P12, P30-P34 (Note)			80	mA
ΣI _{OL(peak)}	"L" total peak output current P13-P17 (Note)			80	mA
ΣI _{OL(peak)}	"L" total peak output current P20-P27, P40-P44 (Note)			80	mA
ΣI _{OH(avg)}	"H" total average output current P00-P07, P10-P17, P30-P34 (Note)			-40	mA
ΣI _{OH(avg)}	"H" total average output current P20, P21, P24-P27, P40-P44 (Note)			-40	mA
ΣI _{OL(avg)}	"L" total average output current P00-P07, P10-P12, P30-P34 (Note)			40	mA
ΣI _{OL(avg)}	"L" total average output current P13-P17 (Note)			40	mA
ΣI _{OL(avg)}	"L" total average output current P20-P27, P40-P44 (Note)			40	mA

Note : The total output current is the sum of all the currents flowing through all the applicable ports. The total average current is an average value measured over 100 ms. The total peak current is the peak value of all the currents.

Table 8 Recommended operating conditions (2)
(VCC = 2.7 to 5.5 V, Ta = -20 to 85 °C, unless otherwise noted)

Symbol	Parameter		Limits			Unit
			Min.	Typ.	Max.	
IOH(peak)	"H" peak output current	P00–P07, P10–P17, P20, P21, P24–P27, P30–P34, P40–P44 (Note 1)			-10	mA
IOL(peak)	"L" peak output current	P00–P07, P10–P12, P20–P27, P30–P34, P40–P44 (Note 1)			10	mA
IOL(peak)	"L" peak output current	P13–P17 (Note 1)			20	mA
IOH(avg)	"H" average output current	P00–P07, P10–P17, P20, P21, P24–P27, P30–P34, P40–P44 (Note 2)			-5	mA
IOL(avg)	"L" average output current	P00–P07, P10–P12, P20–P27, P30–P34, P40–P44 (Note 2)			5	mA
IOL(avg)	"L" peak output current	P13–P17 (Note 2)			15	mA
f(XIN)	Internal clock oscillation frequency (VCC = 4.0 to 5.5V) (Note 3)				8	MHz
f(XIN)	Internal clock oscillation frequency (VCC = 2.7 to 5.5V) (Note 3)				4	kHz

Notes 1: The peak output current is the peak current flowing in each port.

2: The average output current IOL(avg), IOH(avg) are average value measured over 100 ms.

3: When the oscillation frequency has a duty cycle of 50%.

Table 9 Electrical characteristics
 (VCC = 2.7 to 5.5 V, VSS = 0 V, Ta = -20 to 85 °C, unless otherwise noted)

Symbol	Parameter	Test conditions	Limits			Unit
			Min.	Typ.	Max.	
VOH	"H" output voltage P00-P07, P10-P17, P20, P21, P24-P27, P30-P34, P40-P44 (Note)	IOH = -10 mA VCC = 4.0-5.5 V	VCC-2.0			V
		IOH = -1.0 mA VCC = 2.7-5.5 V	VCC-1.0			V
VOL	"L" output voltage P00-P07, P10-P12, P20-P27 P30-P34, P40-P44	IOH = 10 mA VCC = 4.0-5.5 V			2.0	V
		IOH = 1.0 mA VCC = 2.7-5.5 V			1.0	V
VOL	"L" output voltage P13-P17	IOH = 20 mA VCC = 4.0-5.5 V			2.0	V
		IOH = 10 mA VCC = 2.7-5.5 V			1.0	V
VT+~VT-	Hysteresis CNTR0, CNTR1, INT0~INT3			0.4		V
VT+~VT-	Hysteresis RxD, SCLK			0.5		V
VT+~VT-	Hysteresis RESET			0.5		V
IiH	"H" input current P00-P07, P10-P17, P20, P21, P24-P27, P30-P34, P40-P44	Vi = VCC			5.0	μA
IiH	"H" input current RESET, CNVSS	Vi = VCC			5.0	μA
IiH	"H" input current XIN	Vi = VCC		4		μA
IiL	"L" input current P00-P07, P10-P17, P20-P27 P30-P34, P40-P44	Vi = VSS			-5.0	μA
IiL	"L" input current RESET, CNVSS	Vi = VSS			-5.0	μA
IiL	"L" input current XIN	Vi = VSS		-4		μA
VRAM	RAM hold voltage	When clock stopped	2.0		5.5	V

Note: P25 is measured when the P25/TxD P-channel output disable bit of the UART control register (bit 4 of address 001B16) is "0".

Table 10 Electrical characteristics

(VCC = 2.7 to 5.5 V, VSS = 0 V, Ta = -20 to 85 °C, unless otherwise noted)

Symbol	Parameter	Test conditions	Limits			Unit	
			Min.	Typ.	Max.		
ICC	Power source current	High-speed mode f(XIN) = 8 MHz f(XCIN) = 32.768 kHz Output transistors "off"		6.8	13	mA	
		High-speed mode f(XIN) = 8 MHz (in WIT state) f(XCIN) = 32.768 kHz Output transistors "off"		1.6		mA	
		Low-speed mode f(XIN) = stopped f(XCIN) = 32.768 kHz Output transistors "off"		60	200	μA	
		Low-speed mode f(XIN) = stopped f(XCIN) = 32.768 kHz (in WIT state) Output transistors "off"		20	40	μA	
		Low-speed mode (VCC = 3 V) f(XIN) = stopped f(XCIN) = 32.768 kHz Output transistors "off"		20	55	μA	
		Low-speed mode (VCC = 3 V) f(XIN) = stopped f(XCIN) = 32.768 kHz (in WIT state) Output transistors "off"		5.0	10.0	μA	
		Middle-speed mode f(XIN) = 8 MHz f(XCIN) = stopped Output transistors "off"		4.0	7.0	mA	
		Middle-speed mode f(XIN) = 8 MHz (in WIT state) f(XCIN) = stopped Output transistors "off"		1.5		mA	
		Increment when A-D conversion is executed f(XIN) = 8 MHz		800		μA	
		All oscillation stopped (in STP state) Output transistors "off"	Ta = 25 °C		0.1	1.0	μA
			Ta = 85 °C			10	μA

Table 11 A-D converter characteristics

(VCC = 2.7 to 5.5 V, VSS = AVSS = 0 V, Ta = -20 to 85 °C, f(XIN) = 8 MHz, unless otherwise noted)

Symbol	Parameter	Test conditions	Limits			Unit
			Min.	Typ.	Max.	
–	Resolution				10	bit
–	Absolute accuracy (excluding quantization error)				±4	LSB
tCONV	Conversion time				61	tc(φ)
RLADDER	Ladder resistor			35		kΩ
IVREF	Reference power source input current	VREF = 5.0 V	50	150	200	μA
Ii(AD)	A-D port input current			0.5	5.0	μA

TIMING REQUIREMENTS

Table 12 Timing requirements (1)

(V_{CC} = 4.0 to 5.5 V, V_{SS} = 0 V, T_a = -20 to 85 °C, unless otherwise noted)

Symbol	Parameter	Limits			Unit
		Min.	Typ.	Max.	
t _w ($\overline{\text{RESET}}$)	Reset input "L" pulse width	2			μs
t _c (X _{IN})	External clock input cycle time	125			ns
t _{WH} (X _{IN})	External clock input "H" pulse width	50			ns
t _{WL} (X _{IN})	External clock input "L" pulse width	50			ns
t _c (CNTR)	CNTR ₀ , CNTR ₁ input cycle time	200			ns
t _{WH} (CNTR)	CNTR ₀ , CNTR ₁ , INT ₀ -INT ₃ input "H" pulse width	80			ns
t _{WL} (CNTR)	CNTR ₀ , CNTR ₁ , INT ₀ -INT ₃ input "L" pulse width	80			ns
t _c (SCLK)	Serial I/O clock input cycle time (Note)	800			ns
t _{WH} (SCLK)	Serial I/O clock input "H" pulse width (Note)	370			ns
t _{WL} (SCLK)	Serial I/O clock input "L" pulse width (Note)	370			ns
t _{su} (RxD-SCLK)	Serial I/O input setup time	220			ns
t _h (SCLK-RxD)	Serial I/O input hold time	100			ns

Note : When f(X_{IN}) = 8 MHz and bit 6 of address 001A₁₆ is "1" (clock synchronous).
Divide this value by four when f(X_{IN}) = 8 MHz and bit 6 of address 001A₁₆ is "0" (UART).

Table 13 Timing requirements (2)

(V_{CC} = 2.7 to 4.0 V, V_{SS} = 0 V, T_a = -20 to 85 °C, unless otherwise noted)

Symbol	Parameter	Limits			Unit
		Min.	Typ.	Max.	
t _w ($\overline{\text{RESET}}$)	Reset input "L" pulse width	2			μs
t _c (X _{IN})	External clock input cycle time	250			ns
t _{WH} (X _{IN})	External clock input "H" pulse width	100			ns
t _{WL} (X _{IN})	External clock input "L" pulse width	100			ns
t _c (CNTR)	CNTR ₀ , CNTR ₁ input cycle time	500			ns
t _{WH} (CNTR)	CNTR ₀ , CNTR ₁ , INT ₀ -INT ₃ input "H" pulse width	230			ns
t _{WL} (CNTR)	CNTR ₀ , CNTR ₁ , INT ₀ -INT ₃ input "L" pulse width	230			ns
t _c (SCLK)	Serial I/O clock input cycle time (Note)	2000			ns
t _{WH} (SCLK)	Serial I/O clock input "H" pulse width (Note)	950			ns
t _{WL} (SCLK)	Serial I/O clock input "L" pulse width (Note)	950			ns
t _{su} (RxD-SCLK)	Serial I/O input setup time	400			ns
t _h (SCLK-RxD)	Serial I/O input hold time	200			ns

Note : When f(X_{IN}) = 8 MHz and bit 6 of address 001A₁₆ is "1" (clock synchronous).
Divide this value by four when f(X_{IN}) = 8 MHz and bit 6 of address 001A₁₆ is "0" (UART).

Table 14 Switching characteristics 1

(V_{CC} = 4.0 to 5.5 V, V_{SS} = 0 V, T_a = -20 to 85 °C, unless otherwise noted)

Symbol	Parameter	Limits			Unit
		Min.	Typ.	Max.	
t _{WH} (SCLK)	Serial I/O clock output "H" pulse width	t _c (SCLK)/2-30			ns
t _{WL} (SCLK)	Serial I/O clock output "L" pulse width	t _c (SCLK)/2-30			ns
t _d (SCLK-TxD)	Serial I/O output delay time (Note 1)			140	ns
t _v (SCLK-TxD)	Serial I/O output valid time (Note 1)	-30			ns
t _r (SCLK)	Serial I/O clock output rising time			30	ns
t _f (SCLK)	Serial I/O clock output falling time			30	ns
t _r (CMOS)	CMOS output rising time (Note 2)		10	30	ns
t _f (CMOS)	CMOS output falling time (Note 2)		10	30	ns

Notes 1: For t_{WH}(SCLK), t_{WL}(SCLK), when the P51/TxD P-channel output disable bit of the UART control register (bit 4 of address 001B16) is "0".
 2: The XOUT pin is excluded.

Table 15 Switching characteristics 2

(V_{CC} = 2.7 to 4.0 V, V_{SS} = 0 V, T_a = -20 to 85 °C, unless otherwise noted)

Symbol	Parameter	Limits			Unit
		Min.	Typ.	Max.	
t _{WH} (SCLK)	Serial I/O clock output "H" pulse width	t _c (SCLK)/2-50			ns
t _{WL} (SCLK)	Serial I/O clock output "L" pulse width	t _c (SCLK)/2-50			ns
t _d (SCLK-TxD)	Serial I/O output delay time (Note 1)			350	ns
t _v (SCLK-TxD)	Serial I/O output valid time (Note 1)	-30			ns
t _r (SCLK)	Serial I/O clock output rising time			50	ns
t _f (SCLK)	Serial I/O clock output falling time			50	ns
t _r (CMOS)	CMOS output rising time (Note 2)		20	50	ns
t _f (CMOS)	CMOS output falling time (Note 2)		20	50	ns

Notes 1: For t_{WH}(SCLK), t_{WL}(SCLK), when the P51/TxD P-channel output disable bit of the UART control register (bit 4 of address 001B16) is "0".
 2: The XOUT pin is excluded.

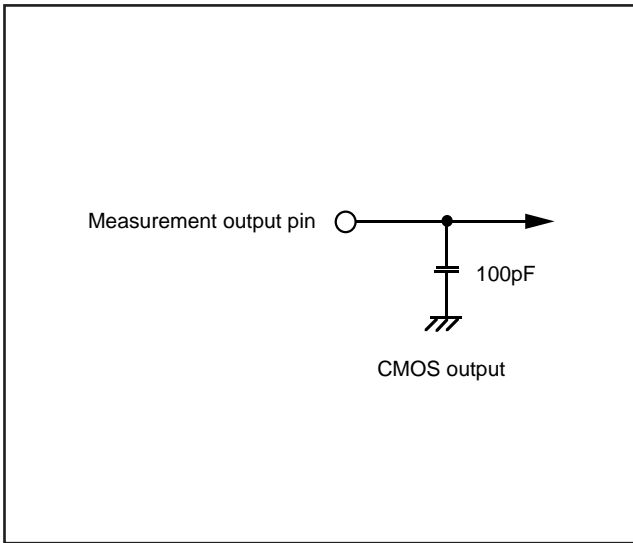

Fig. 38 Circuit for measuring output switching characteristics (1)

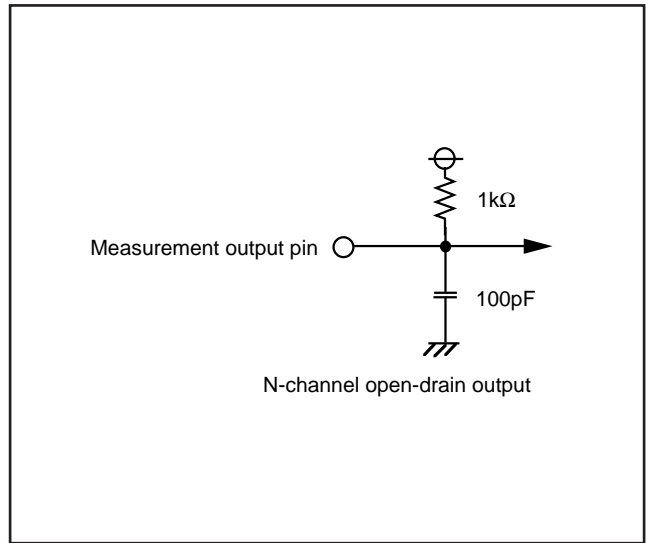

Fig. 39 Circuit for measuring output switching characteristics (2)

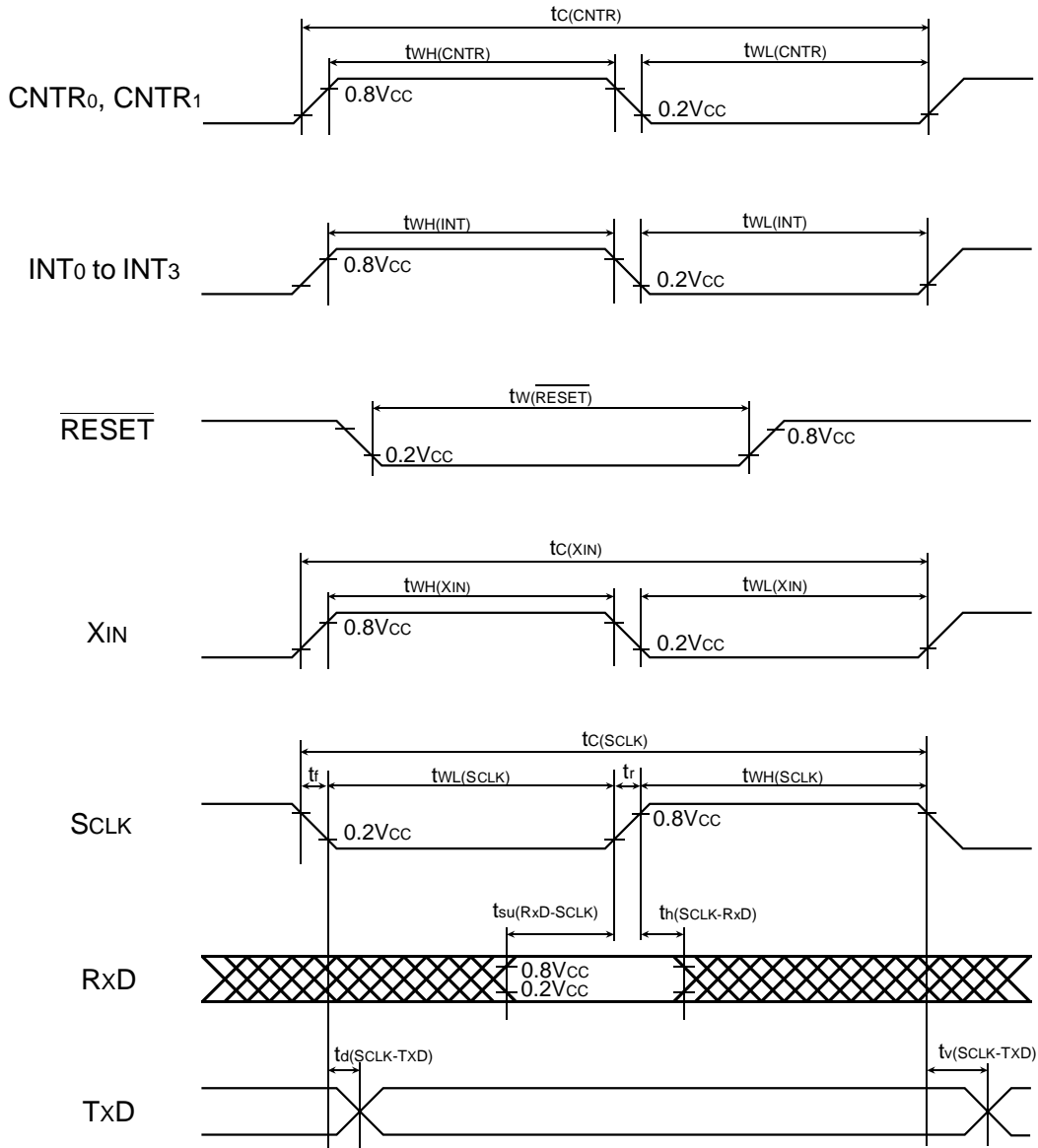

Fig. 40 Timing diagram

MASK ROM CONFIRMATION FORM

GZZ-SH53-11B<86A0>

Mask ROM number	
-----------------	--

**740 FAMILY MASK ROM CONFIRMATION FORM
SINGLE-CHIP MICROCOMPUTER M38503M2-XXXSP/FP
MITSUBISHI ELECTRIC**

Receipt	Date:	
	Section head signature	Supervisor signature

Note : Please fill in all items marked *.

* Customer	Company name	TEL ()	Issuance signature	Submitted by	Supervisor
	Date issued	Date:			

* 1. Confirmation

Specify the name of the product being ordered and the type of EPROMs submitted.

Three EPROMs are required for each pattern.

If at least two of the three sets of EPROMs submitted contain identical data, we will produce masks based on this data. We shall assume the responsibility for errors only if the mask ROM data on the products we produce differs from this data. Thus, extreme care must be taken to verify the data in the submitted EPROMs.

Microcomputer name: M38503M2-XXXSP M38503M2-XXXFP

Checksum code for entire EPROM

--	--	--	--

 (hexadecimal notation)

EPROM type (indicate the type used)

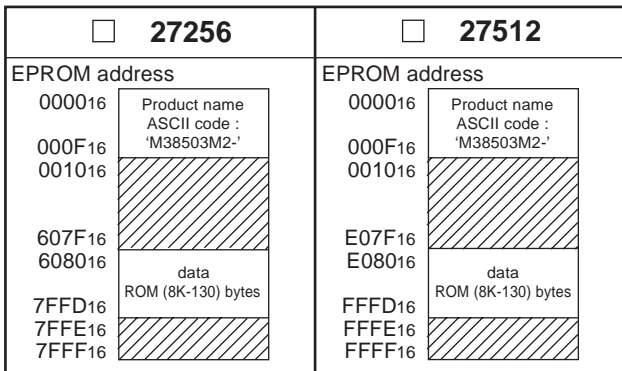

In the address space of the microcomputer, the internal ROM area is from address 6080₁₆ to FFFD₁₆. The reset vector is stored in addresses FFFC₁₆ and FFFD₁₆.

- (1) Set the data in the unused area (the shaded area of the diagram) to "FF₁₆".
- (2) The ASCII codes of the product name "M38503M2-" must be entered in addresses 0000₁₆ to 0008₁₆. And set the data "FF₁₆" in addresses 0009₁₆ to 000F₁₆. The ASCII codes and addresses are listed to the right in hexadecimal notation.

Address	Address	Address
0000 ₁₆	'M' = 4D ₁₆	0008 ₁₆
0001 ₁₆	'3' = 33 ₁₆	'_' = 2D ₁₆
0002 ₁₆	'8' = 38 ₁₆	0009 ₁₆
0003 ₁₆	'5' = 35 ₁₆	FF ₁₆
0004 ₁₆	'0' = 30 ₁₆	000A ₁₆
0005 ₁₆	'3' = 33 ₁₆	FF ₁₆
0006 ₁₆	'M' = 4D ₁₆	000B ₁₆
0007 ₁₆	'2' = 32 ₁₆	FF ₁₆
		000C ₁₆
		FF ₁₆
		000D ₁₆
		FF ₁₆
		000E ₁₆
		FF ₁₆
		000F ₁₆
		FF ₁₆

GZZ-SH53-11B<86A0>

Mask ROM number	
-----------------	--

740 FAMILY MASK ROM CONFIRMATION FORM
SINGLE-CHIP MICROCOMPUTER M38503M2-XXXSP/FP
MITSUBISHI ELECTRIC

We recommend the use of the following pseudo-command to set the start address of the assembler source program because ASCII codes of the product name are written to addresses 0000₁₆ to 0008₁₆ of EPROM.

EPROM type	27256	27512
The pseudo-command	*= Δ \$8000 .BYTE Δ 'M38503M2-'	*= Δ \$0000 .BYTE Δ 'M38503M2-'

Note : If the name of the product written to the EPROMs does not match the name of the mask confirmation form, the ROM will not be processed.

※ 2. Mark specification

Mark specification must be submitted using the correct form for the package being ordered. Fill out the appropriate mark specification form (42P4B for M38503M2-XXXSP, 42P2R-A for M38503M2-XXXFP) and attach it to the mask ROM confirmation form.

※ 3. Usage conditions

Please answer the following questions about usage for use in our product inspection :

(1) How will you use the X_{IN}-X_{OUT} oscillator?

- Ceramic resonator Quartz crystal
 External clock input Other ()

At what frequency? f(X_{IN}) = MHz

(2) Which function will you use the pins P₂₁/X_{CIN} and P₂₀/X_{COU}T as P₂₁ and P₂₀, or X_{CIN} and X_{COU}T ?

- Ports P₂₁ and P₂₀ function X_{CIN} and X_{COU}T function (external resonator)

※ 4. Comments

MASK ROM CONFIRMATION FORM

GZZ-SH11-40A<6YA0>

Mask ROM number	
-----------------	--

**740 FAMILY MASK ROM CONFIRMATION FORM
SINGLE-CHIP MICROCOMPUTER M38503M4-XXXSP/FP
MITSUBISHI ELECTRIC**

Receipt	Date:	
	Section head signature	Supervisor signature

Note : Please fill in all items marked *.

* Customer	Company name	TEL ()	Issuance signature	Submitted by	Supervisor
	Date issued	Date:			

* 1. Confirmation

Specify the name of the product being ordered and the type of EPROMs submitted.
Three EPROMs are required for each pattern.

If at least two of the three sets of EPROMs submitted contain identical data, we will produce masks based on this data. We shall assume the responsibility for errors only if the mask ROM data on the products we produce differs from this data. Thus, extreme care must be taken to verify the data in the submitted EPROMs.

Microcomputer name: M38503M4-XXXSP M38503M4-XXXFP

Checksum code for entire EPROM

--	--	--	--

 (hexadecimal notation)

EPROM type (indicate the type used)

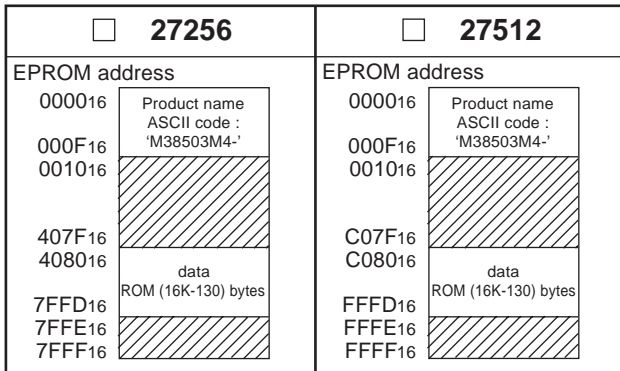

In the address space of the microcomputer, the internal ROM area is from address C080₁₆ to FFFD₁₆. The reset vector is stored in addresses FFFC₁₆ and FFFD₁₆.

- (1) Set the data in the unused area (the shaded area of the diagram) to "FF₁₆".
- (2) The ASCII codes of the product name "M38503M4-" must be entered in addresses 0000₁₆ to 0008₁₆. And set the data "FF₁₆" in addresses 0009₁₆ to 000F₁₆. The ASCII codes and addresses are listed to the right in hexadecimal notation.

Address	<table border="1" style="width: 100%; border-collapse: collapse;"> <tr><td style="width: 20px;">0000₁₆</td><td>'M' = 4D₁₆</td></tr> <tr><td>0001₁₆</td><td>'3' = 33₁₆</td></tr> <tr><td>0002₁₆</td><td>'8' = 38₁₆</td></tr> <tr><td>0003₁₆</td><td>'5' = 35₁₆</td></tr> <tr><td>0004₁₆</td><td>'0' = 30₁₆</td></tr> <tr><td>0005₁₆</td><td>'3' = 33₁₆</td></tr> <tr><td>0006₁₆</td><td>'M' = 4D₁₆</td></tr> <tr><td>0007₁₆</td><td>'4' = 34₁₆</td></tr> </table>	0000 ₁₆	'M' = 4D ₁₆	0001 ₁₆	'3' = 33 ₁₆	0002 ₁₆	'8' = 38 ₁₆	0003 ₁₆	'5' = 35 ₁₆	0004 ₁₆	'0' = 30 ₁₆	0005 ₁₆	'3' = 33 ₁₆	0006 ₁₆	'M' = 4D ₁₆	0007 ₁₆	'4' = 34 ₁₆	<table border="1" style="width: 100%; border-collapse: collapse;"> <tr><td style="width: 20px;">0008₁₆</td><td>'-' = 2D₁₆</td></tr> <tr><td>0009₁₆</td><td>FF₁₆</td></tr> <tr><td>000A₁₆</td><td>FF₁₆</td></tr> <tr><td>000B₁₆</td><td>FF₁₆</td></tr> <tr><td>000C₁₆</td><td>FF₁₆</td></tr> <tr><td>000D₁₆</td><td>FF₁₆</td></tr> <tr><td>000E₁₆</td><td>FF₁₆</td></tr> <tr><td>000F₁₆</td><td>FF₁₆</td></tr> </table>	0008 ₁₆	'-' = 2D ₁₆	0009 ₁₆	FF ₁₆	000A ₁₆	FF ₁₆	000B ₁₆	FF ₁₆	000C ₁₆	FF ₁₆	000D ₁₆	FF ₁₆	000E ₁₆	FF ₁₆	000F ₁₆	FF ₁₆
0000 ₁₆	'M' = 4D ₁₆																																	
0001 ₁₆	'3' = 33 ₁₆																																	
0002 ₁₆	'8' = 38 ₁₆																																	
0003 ₁₆	'5' = 35 ₁₆																																	
0004 ₁₆	'0' = 30 ₁₆																																	
0005 ₁₆	'3' = 33 ₁₆																																	
0006 ₁₆	'M' = 4D ₁₆																																	
0007 ₁₆	'4' = 34 ₁₆																																	
0008 ₁₆	'-' = 2D ₁₆																																	
0009 ₁₆	FF ₁₆																																	
000A ₁₆	FF ₁₆																																	
000B ₁₆	FF ₁₆																																	
000C ₁₆	FF ₁₆																																	
000D ₁₆	FF ₁₆																																	
000E ₁₆	FF ₁₆																																	
000F ₁₆	FF ₁₆																																	

GZZ-SH11-40A<6YA0>

Mask ROM number	
-----------------	--

**740 FAMILY MASK ROM CONFIRMATION FORM
SINGLE-CHIP MICROCOMPUTER M38503M4-XXXSP/FP
MITSUBISHI ELECTRIC**

We recommend the use of the following pseudo-command to set the start address of the assembler source program because ASCII codes of the product name are written to addresses 0000₁₆ to 0008₁₆ of EPROM.

EPROM type	27256	27512
The pseudo-command	*=△\$8000 .BYTE △'M38503M4-'	*=△\$0000 .BYTE △'M38503M4-'

Note : If the name of the product written to the EPROMs does not match the name of the mask confirmation form, the ROM will not be processed.

※ 2. Mark specification

Mark specification must be submitted using the correct form for the package being ordered. Fill out the appropriate mark specification form (42P4B for M38503M4-XXXSP, 42P2R-A for M38503M4-XXXFP) and attach it to the mask ROM confirmation form.

※ 3. Usage conditions

Please answer the following questions about usage for use in our product inspection :

(1) How will you use the XIN-XOUT oscillator?

- | | |
|---|---|
| <input type="checkbox"/> Ceramic resonator | <input type="checkbox"/> Quartz crystal |
| <input type="checkbox"/> External clock input | <input type="checkbox"/> Other () |

At what frequency? f(XIN) = MHz

(2) Which function will you use the pins P21/XCIN and P20/XCOUT as P21 and P20, or XCIN and XCOUT ?

- | | |
|---|---|
| <input type="checkbox"/> Ports P21 and P20 function | <input type="checkbox"/> XCIN and XCOUT function (external resonator) |
|---|---|

※ 4. Comments

ROM PROGRAMMING CONFIRMATION FORM

GZZ-SH11-41A<6YA0>

ROM number	
------------	--

**740 FAMILY ROM PROGRAMMING CONFIRMATION FORM
SINGLE-CHIP MICROCOMPUTER M38503E4-XXXSP/FP
MITSUBISHI ELECTRIC**

Receipt	Date:	
	Section head signature	Supervisor signature

Note : Please fill in all items marked *.

* Customer	Company name	TEL ()	Issuance signature	Submitted by	Supervisor
	Date issued	Date:			

* 1. Confirmation

Specify the name of the product being ordered and the type of EPROMs submitted.

Three EPROMs are required for each pattern.

If at least two of the three sets of EPROMs submitted contain identical data, we will produce ROM programming based on this data. We shall assume the responsibility for errors only if the programming data on the products we produce differs from this data. Thus, extreme care must be taken to verify the data in the submitted EPROMs.

Microcomputer name: M38503E4-XXXSP M38503E4-XXXFP

Checksum code for entire EPROM

--	--	--	--

 (hexadecimal notation)

EPROM type (indicate the type used)

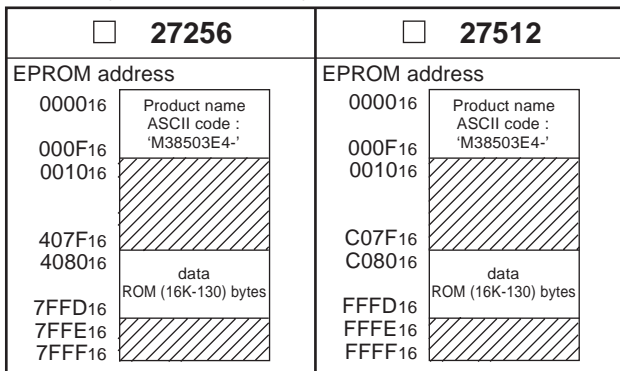

In the address space of the microcomputer, the internal ROM area is from address C080₁₆ to FFFD₁₆. The reset vector is stored in addresses FFFC₁₆ and FFFD₁₆.

- (1) Set the data in the unused area (the shaded area of the diagram) to "FF₁₆".
- (2) The ASCII codes of the product name "M38503E4-" must be entered in addresses 0000₁₆ to 0008₁₆. And set the data "FF₁₆" in addresses 0009₁₆ to 000F₁₆. The ASCII codes and addresses are listed to the right in hexadecimal notation.

Address		Address	
0000 ₁₆	'M' = 4D ₁₆	0008 ₁₆	'-' = 2D ₁₆
0001 ₁₆	'3' = 33 ₁₆	0009 ₁₆	FF ₁₆
0002 ₁₆	'8' = 38 ₁₆	000A ₁₆	FF ₁₆
0003 ₁₆	'5' = 35 ₁₆	000B ₁₆	FF ₁₆
0004 ₁₆	'0' = 30 ₁₆	000C ₁₆	FF ₁₆
0005 ₁₆	'3' = 33 ₁₆	000D ₁₆	FF ₁₆
0006 ₁₆	'E' = 45 ₁₆	000E ₁₆	FF ₁₆
0007 ₁₆	'4' = 34 ₁₆	000F ₁₆	FF ₁₆

GZZ-SH11-41A<6YA0>

ROM number	
------------	--

**740 FAMILY ROM PROGRAMMING CONFIRMATION FORM
SINGLE-CHIP MICROCOMPUTER M38503E4-XXXSP/FP
MITSUBISHI ELECTRIC**

We recommend the use of the following pseudo-command to set the start address of the assembler source program because ASCII codes of the product name are written to addresses 0000₁₆ to 0008₁₆ of EPROM.

EPROM type	27256	27512
The pseudo-command	*= Δ \$8000 .BYTE Δ 'M38503E4-'	*= Δ \$0000 .BYTE Δ 'M38503E4-'

Note : If the name of the product written to the EPROMs does not match the name of the ROM programming confirmation form, the ROM will not be processed.

※ 2. Mark specification

Mark specification must be submitted using the correct form for the package being ordered. Fill out the appropriate mark specification form; 42P2R-A for the M38503E4-XXXFP, the shrink DIP package Mark Specification Form (only for built-in One Time PROM microcomputer) for the M38503E4-XXXSP; and attach it to the ROM programming confirmation form.

※ 3. Usage conditions

Please answer the following questions about usage for use in our product inspection :

(1) How will you use the XIN-XOUT oscillator?

- Ceramic resonator Quartz crystal
 External clock input Other ()

At what frequency? f(XIN) = MHz

(2) Which function will you use the pins P21/XCIN and P20/XCOUT as P21 and P20, or XCIN and XCOUT ?

- Ports P21 and P20 function XCIN and XCOUT function (external resonator)

※ 4. Comments

MARK SPECIFICATION FORM

42P2R-A (42-PIN SHRINK SOP) MARK SPECIFICATION FORM

Mitsubishi IC catalog name

Please choose one of the marking types below (A, B, C), and enter the Mitsubishi catalog name and the special mark (if needed).

A. Standard Mitsubishi Mark

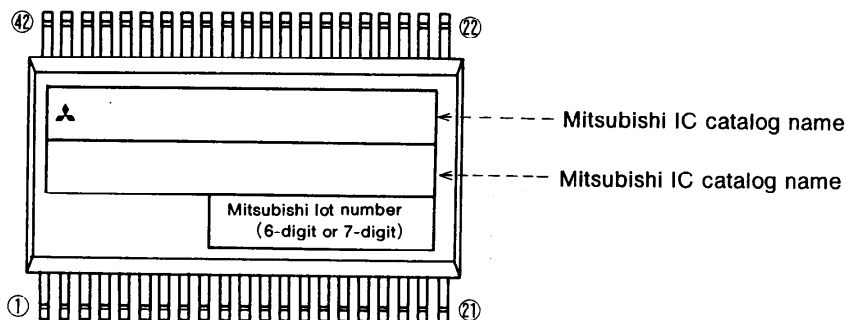

B. Customer's Parts Number + Mitsubishi catalog name

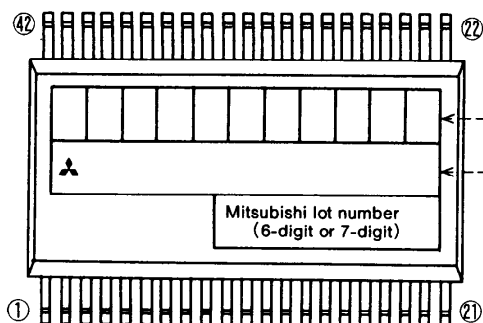

Customer's Parts Number
 Note: The fonts and size of characters are standard Mitsubishi type.

Mitsubishi IC catalog name
 Note1: The mark field should be written right aligned.
 2: The fonts and size of characters are standard Mitsubishi type.

3: Customer's Parts Number can be up to 11 characters: Only 0~9, A~Z, +, -, /, (,), &, ©, · (periods), , (commas) are usable.

4: If the Mitsubishi logo is not required, check the box below.

Mitsubishi logo is not required

C. Special Mark Required

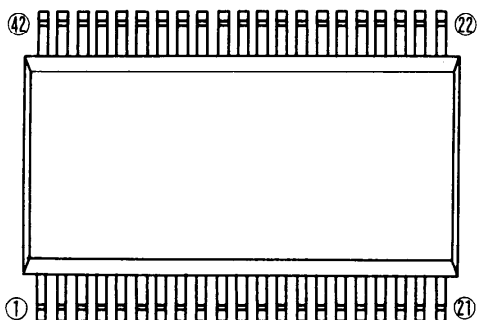

Note1: If the Special Mark is to be printed, indicate the desired layout of the mark in the left figure. The layout will be duplicated as close as possible. Mitsubishi lot number (6-digit or 7-digit) and Mask ROM number (3-digit) are always marked.

2: If the customer's trade mark logo must be used in the Special Mark, check the box below. Please submit a clean original of the logo. For the new special character fonts a clean font original (ideally logo drawing) must be submitted.

Special logo required

3: The standard Mitsubishi font is used for all characters except for a logo.

42P4B (42-PIN SHRINK DIP) MARK SPECIFICATION FORM

Mitsubishi IC catalog name

Please choose one of the marking types below (A, B, C), and enter the Mitsubishi IC catalog name and the special mark (if needed).

A. Standard Mitsubishi Mark

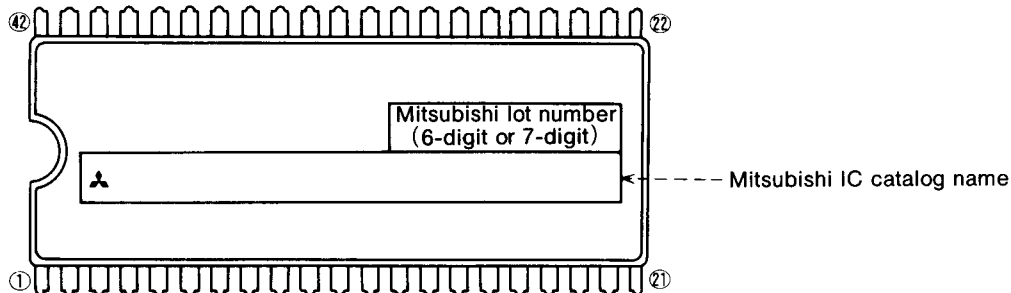

B. Customer's Parts Number + Mitsubishi Catalog Name

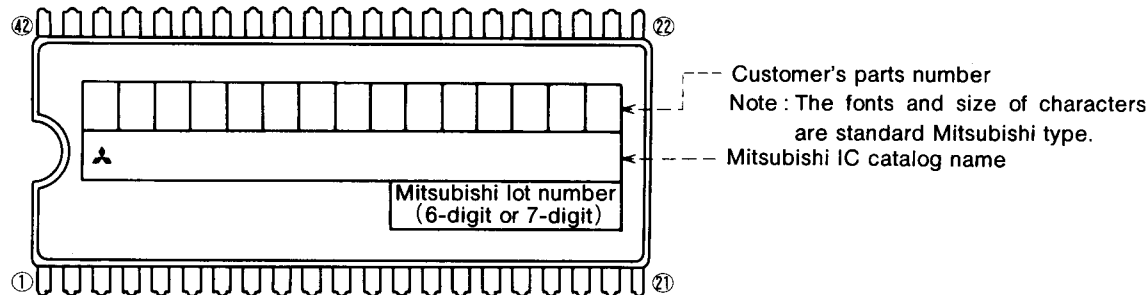

Note1 : The mark field should be written right aligned.

2: The fonts and size of characters are standard Mitsubishi type.

3: Customer's parts number can be up to 15 characters :

Only 0~9, A~Z, +, -, /, (,), &, ©, . (period), and , (comma) are usable.

4: If the Mitsubishi logo is not required, check the box on the right.

Mitsubishi logo is not required

C. Special Mark Required

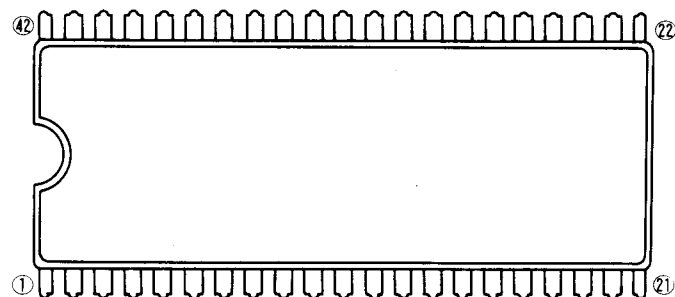

Note1 : If the special mark is to be printed, indicate the desired layout of the mark in the upper figure. The layout will be duplicated as close as possible. Mitsubishi lot number (6-digit or 7-digit) and mask ROM number (3-digit) are always marked.

2: If the customer's trade mark logo must be used in the special mark, check the box below. Please submit a clean original of the logo.

For the new special character fonts a clean font original (ideally logo drawing) must be submitted.

Special logo required

The standard Mitsubishi font is used for all characters except for a logo.

**SHRINK DIP MARK SPECIFICATION FORM
for One Time PROM version microcomputers**

Enter the catalog number of the microcomputer for which this mark specification is intended. (If you do not know the ROM code number, enter XXX in its place.)

The catalog number of the microcomputer

M

A. Standard Mitsubishi Mark

Customer specified part number will be printed together with the ROM code number on the top line.
Enter the desired part number left aligned in the box below. (up to 10 characters)

Note2 :										
										RXXX
	Mitsubishi catalog name (blank model number before writing)									
	Mitsubishi lot number (6-digit or 7-digit)									

Note1 : The following characters can be used in the part number :
Uppercase alphabet, numbers, ampersand, hyphen, period, comma, +, /, (,), ©
(© will be printed at 1.5 x character width)
2 : XXX is the ROM code number.

B. Special Mark Required

If you desire anything other than the standard Mitsubishi mark, it will be treated as a special mark.
Special marks will take longer to produce and should be avoided if possible.
If a special mark is to be printed, indicate the desired layout of the mark in the figure below. The layout will be duplicated as closely as possible.

	
---	--

Note1 : If the customer's trademark logo must be used in the Special Mark, please submit a clean original logo.
Note that special marks require extra cost and time to produce.

PACKAGE OUTLINE

42P2R-A

Plastic 42pin 450mil SSOP

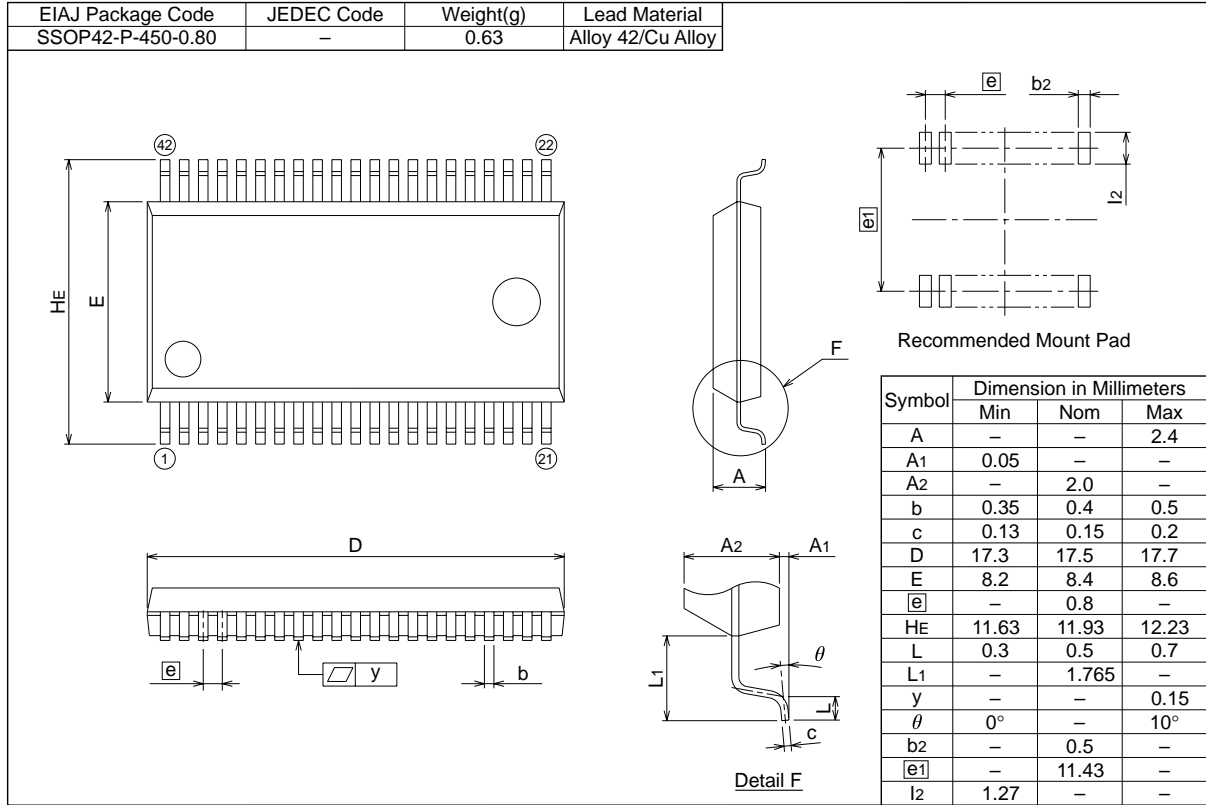

42P4B

Plastic 42pin 600mil SDIP

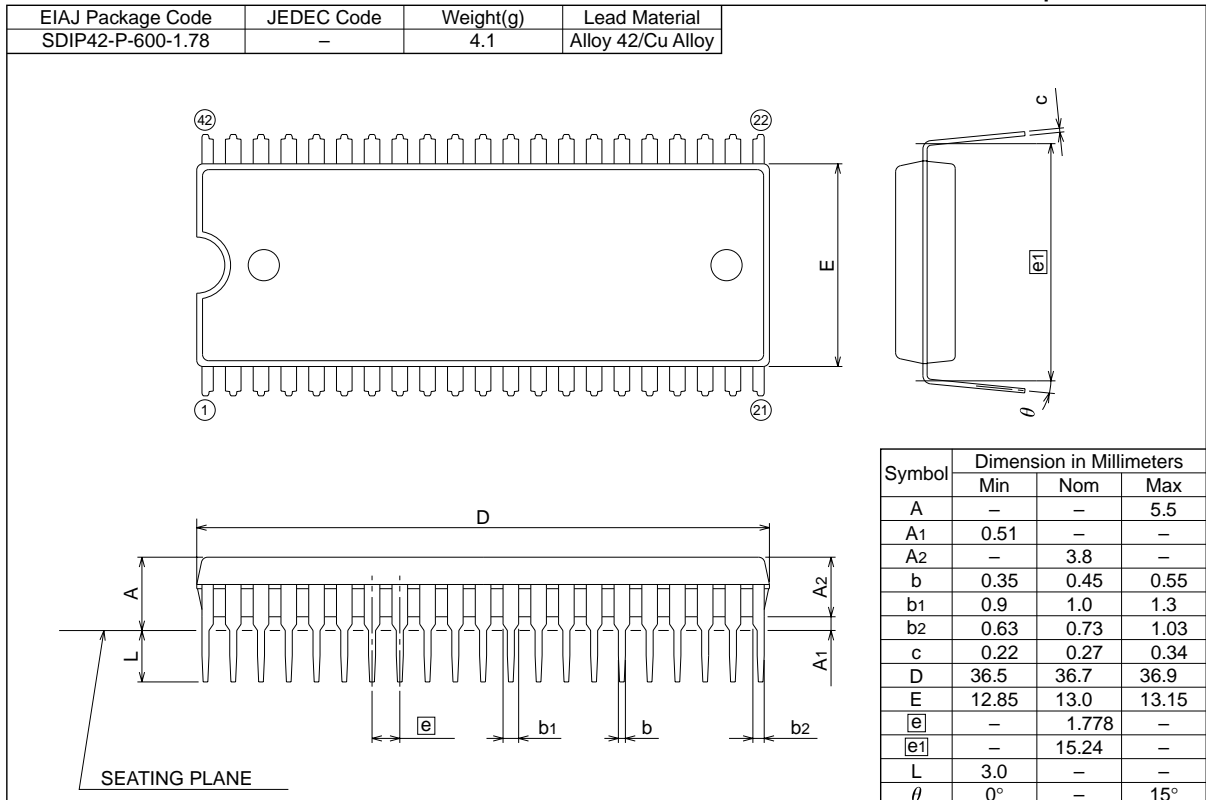

42S1B-A

Metal seal 42pin 600mil DIP

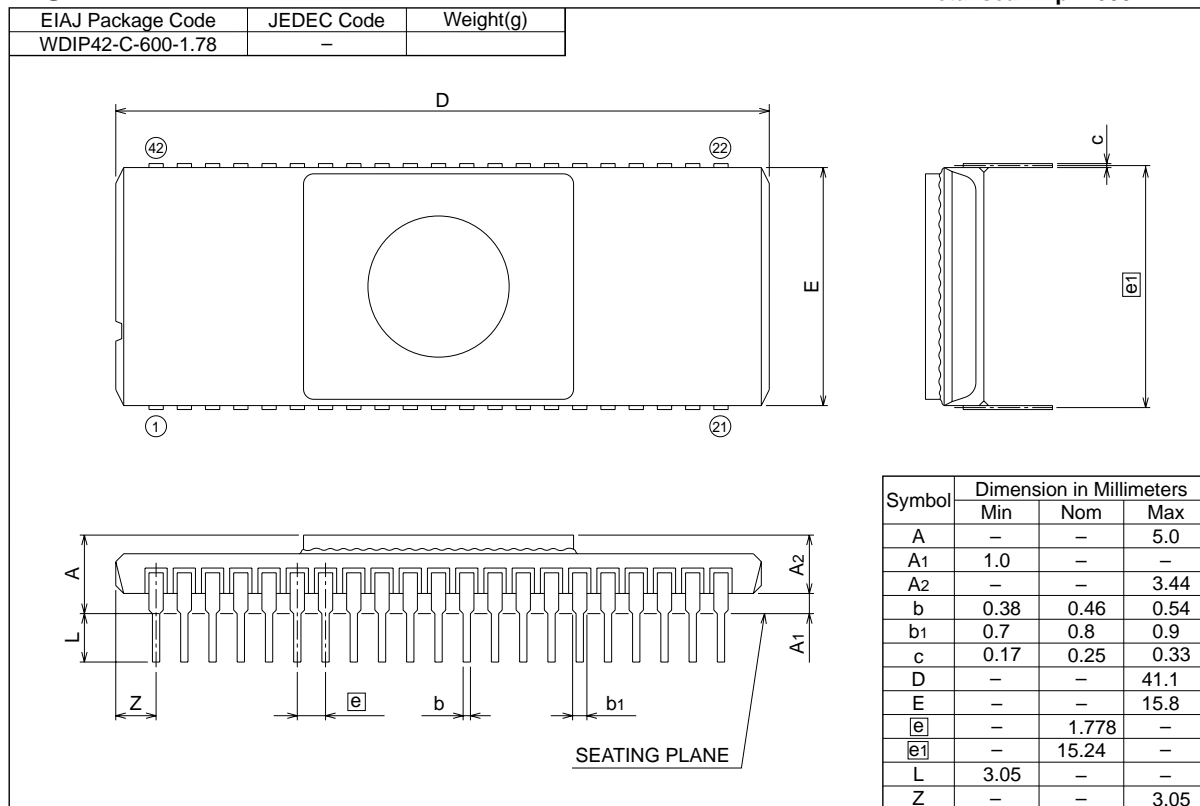

Keep safety first in your circuit designs!

- Mitsubishi Electric Corporation puts the maximum effort into making semiconductor products better and more reliable, but there is always the possibility that trouble may occur with them. Trouble with semiconductors may lead to personal injury, fire or property damage. Remember to give due consideration to safety when making your circuit designs, with appropriate measures such as (i) placement of substitutive, auxiliary circuits, (ii) use of non-flammable material or (iii) prevention against any malfunction or mishap.

Notes regarding these materials

- These materials are intended as a reference to assist our customers in the selection of the Mitsubishi semiconductor product best suited to the customer's application; they do not convey any license under any intellectual property rights, or any other rights, belonging to Mitsubishi Electric Corporation or a third party.
- Mitsubishi Electric Corporation assumes no responsibility for any damage, or infringement of any third-party's rights, originating in the use of any product data, diagrams, charts or circuit application examples contained in these materials.
- All information contained in these materials, including product data, diagrams and charts, represent information on products at the time of publication of these materials, and are subject to change by Mitsubishi Electric Corporation without notice due to product improvements or other reasons. It is therefore recommended that customers contact Mitsubishi Electric Corporation or an authorized Mitsubishi Semiconductor product distributor for the latest product information before purchasing a product listed herein.
- Mitsubishi Electric Corporation semiconductors are not designed or manufactured for use in a device or system that is used under circumstances in which human life is potentially at stake. Please contact Mitsubishi Electric Corporation or an authorized Mitsubishi Semiconductor product distributor when considering the use of a product contained herein for any specific purposes, such as apparatus or systems for transportation, vehicular, medical, aerospace, nuclear, or undersea repeater use.
- The prior written approval of Mitsubishi Electric Corporation is necessary to reprint or reproduce in whole or in part these materials.
- If these products or technologies are subject to the Japanese export control restrictions, they must be exported under a license from the Japanese government and cannot be imported into a country other than the approved destination.
Any diversion or reexport contrary to the export control laws and regulations of Japan and/or the country of destination is prohibited.
- Please contact Mitsubishi Electric Corporation or an authorized Mitsubishi Semiconductor product distributor for further details on these materials or the products contained therein.

REVISION DESCRIPTION LIST

3850 GROUP DATA SHEET

Rev. No.	Revision Description	Rev. date
1.0	First Edition	980817