



# SGS-THOMSON MICROELECTRONICS

## M54HC7245/7640/7643/7645 M74HC7245/7640/7643/7645

### OCTAL BUS TRANSCEIVER (3-STATE): HC7645 NON INVERTING HC7640 INVERTING , HC7643 INVERTING/NON INVERTING

- HIGH SPEED  
 $t_{PD} = 12 \text{ ns (TYP.) at } V_{CC} = 5V$
- LOW POWER DISSIPATION  
 $I_{CC} = 4 \mu A \text{ (MAX.) at } T_A = 25^\circ C$
- HIGH NOISE IMMUNITY  
 $V_H = 1.1 \text{ (TYP.) at } V_{CC} = 5V$
- OUTPUT DRIVE CAPABILITY  
 15 LSTTL LOADS
- SYMMETRICAL OUTPUT IMPEDANCE  
 $|I_{OH}| = I_{OL} = 6 \text{ mA (MIN)}$
- BALANCED PROPAGATION DELAYS  
 $t_{PLH} = t_{PHL}$
- WIDE OPERATING RANGE  
 $V_{CC} \text{ (OPR)} = 2V \text{ to } 6V$
- PIN AND FUNCTION COMPATIBLE  
 WITH 54/74LS245/640/643

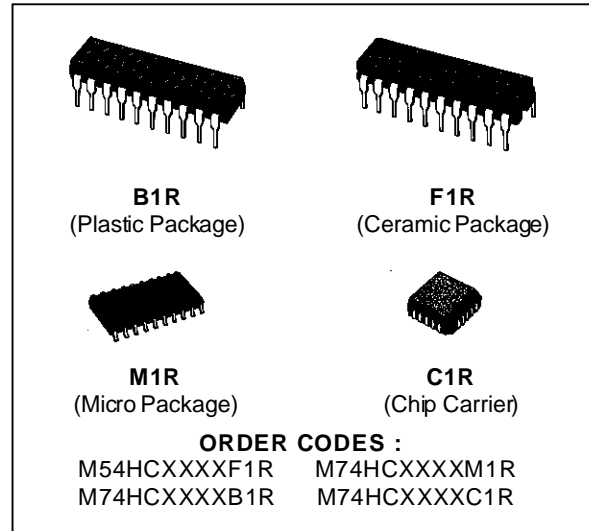

#### DESCRIPTION

The M54/74HC7245 HC7640, HC7643 and HC7645 utilise silicon gate C<sup>2</sup>MOS technology to achieve operating speeds equivalent to LSTTL devices. Along with the low power dissipation and high noise immunity of standard C<sup>2</sup>MOS integrated circuit, it possesses the capability to drive 15 LSTTL loads. These IC's are intended for two-way asynchronous communication between data buses, and the direction of data transmission is determined by DIR input. The enable input ( $\bar{G}$ ) can be used to disable the device so that the buses are effectively isolated. The HC7245/640/7643/7645 have the same pin

configuration and function as the HC245/640/643 and they have a hysteresis characteristics with each input, so HC7245/7640/7643/7645 can be used as a line receiver, etc. All input are equipped with protection circuits against static discharge and transient excess voltage.

IT IS PROHIBITED TO APPLY A SIGNAL TO A BUS TERMINAL WHEN IT IS IN OUTPUT MODE AND WHEN A BUS TERMINAL IS FLOATING (HIGH IMPEDANCE STATE), IT IS REQUESTED TO FIX THE INPUT LEVEL BY MEANS OF EXTERNAL PULL DOWN OR PULL UP RESISTOR.

#### PIN CONNECTION (top view)

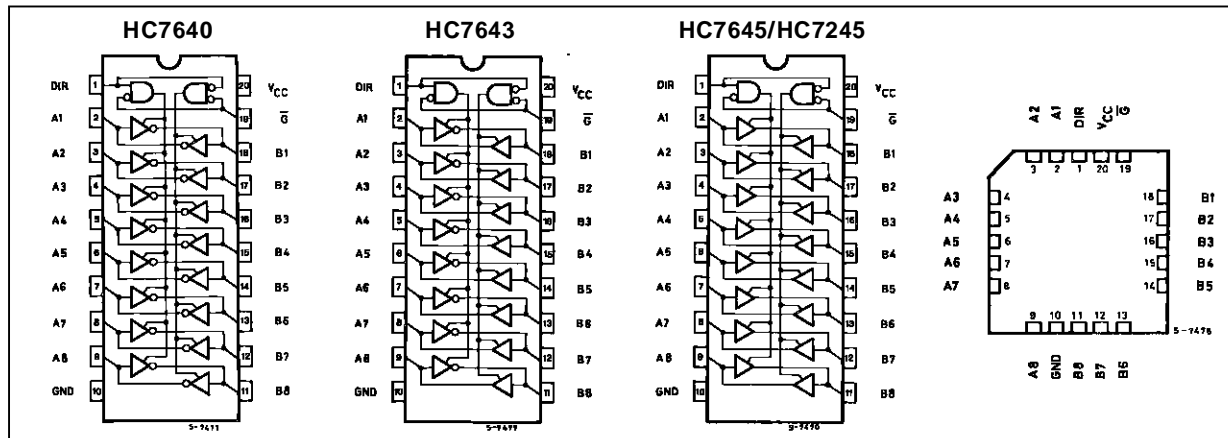

HC7245 is electrically and functionally the same as the HC7645

INPUT AND OUTPUT EQUIVALENT CIRCUIT

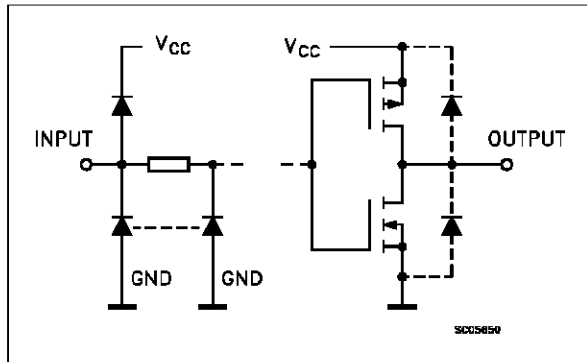

PIN DESCRIPTION

PIN No	SYMBOL	NAME AND FUNCTION
1	DIR	Directional Control
2, 3, 4, 5, 6, 7, 8, 9	A1 to A8	Data Inputs/Outputs
18, 17, 16, 15, 14, 13, 12, 11	B1 to B8	Data Inputs/Outputs
19	$\overline{G}$	Output Enable Input (Active LOW)
10	GND	Ground (0V)
20	Vcc	Positive Supply Voltage

IEC LOGIC SYMBOLS

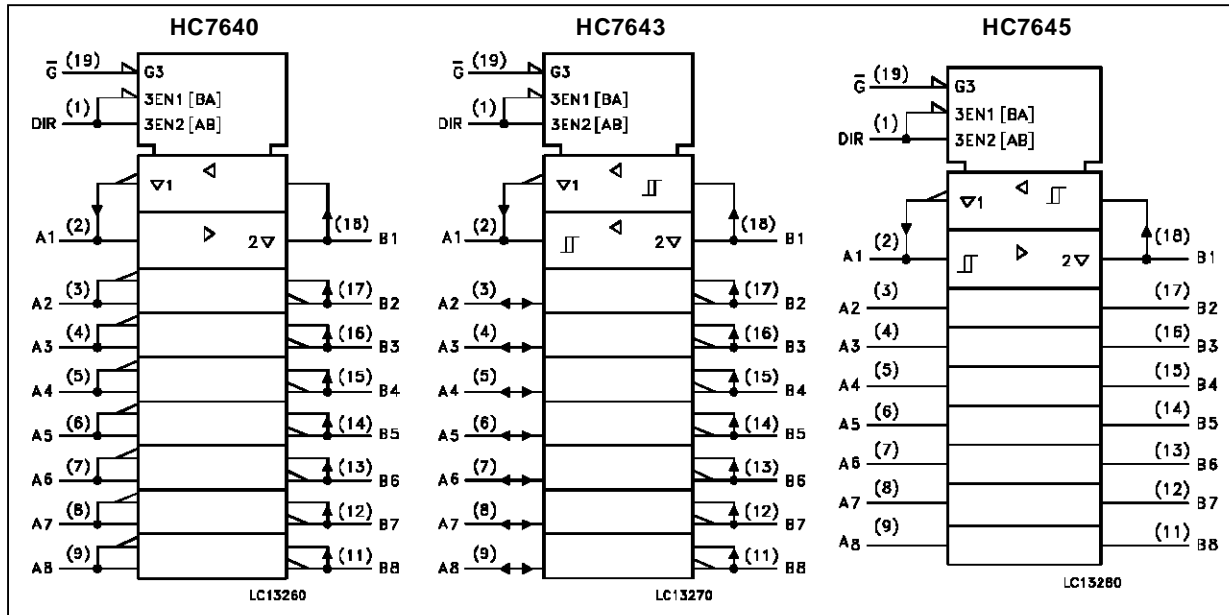

TRUTH TABLE

INPUT		FUNCTION		OUTPUT		
$\overline{G}$	DIR	A BUS	B BUS	HC7640	HC7643	HC7645/7245
L	L	OUTPUT	INPUT	$A = \overline{B}$	$A = B$	$A = B$
L	H	INPUT	OUTPUT	$B = \overline{A}$	$B = \overline{A}$	$B = A$
H	X	Z	Z	Z	Z	Z

X: "H" or "L"  
Z: High impedance

**ABSOLUTE MAXIMUM RATINGS**

Symbol	Parameter	Value	Unit
V <sub>CC</sub>	Supply Voltage	-0.5 to +7	V
V <sub>I</sub>	DC Input Voltage	-0.5 to V <sub>CC</sub> + 0.5	V
V <sub>O</sub>	DC Output Voltage	-0.5 to V <sub>CC</sub> + 0.5	V
I <sub>IK</sub>	DC Input Diode Current	± 20	mA
I <sub>OK</sub>	DC Output Diode Current	± 20	mA
I <sub>O</sub>	DC Output Source Sink Current Per Output Pin	± 35	mA
I <sub>CC</sub> or I <sub>GND</sub>	DC V <sub>CC</sub> or Ground Current	± 70	mA
P <sub>D</sub>	Power Dissipation	500 (*)	mW
T <sub>stg</sub>	Storage Temperature	-65 to +150	°C
T <sub>L</sub>	Lead Temperature (10 sec)	300	°C

Absolute Maximum Ratings are those values beyond which damage to the device may occur. Functional operation under these condition is not implied.

(\*) 500 mW: ≡ 65 °C derate to 300 mW by 10mW/°C: 65 °C to 85 °C

**RECOMMENDED OPERATING CONDITIONS**

Symbol	Parameter	Value	Unit
V <sub>CC</sub>	Supply Voltage	2 to 6	V
V <sub>I</sub>	Input Voltage	0 to V <sub>CC</sub>	V
V <sub>O</sub>	Output Voltage	0 to V <sub>CC</sub>	V
T <sub>op</sub>	Operating Temperature: <b>M54HC Series</b>	-55 to +125	°C
	<b>M74HC Series</b>	-40 to +85	°C

DC SPECIFICATIONS

Symbol	Parameter	Test Conditions		Value						Unit		
		V <sub>CC</sub> (V)		T <sub>A</sub> = 25 °C 54HC and 74HC			-40 to 85 °C 74HC		-55 to 125 °C 54HC			
				Min.	Typ.	Max.	Min.	Max.	Min.		Max.	
V <sub>P</sub>	Positive Threshold Voltage (An, Bn inputs)	2.0		1	1.25	1.5	1	1.5	1	1.5	V	
		4.5		2.3	2.7	3.15	2.3	3.15	2.3	3.15		
		6.0		3	3.5	4.2	3	4.2	3	4.2		
V <sub>N</sub>	Negative Threshold Voltage (An, Bn inputs)	2.0		0.3	0.65	0.9	0.3	0.9	0.3	0.9	V	
		4.5		1.13	1.6	2	1.13	2	1.13	2		
		6.0		1.5	2.3	2.6	1.5	2.6	1.5	2.6		
V <sub>H</sub>	Hysteresis Voltage (An, Bn inputs)	2.0		0.3	0.6	1	0.3	1	0.3	1	V	
		4.5		0.6	1.1	1.4	0.6	1.4	0.6	1.4		
		6.0		0.8	1.2	1.7	0.8	1.7	0.8	1.7		
V <sub>IH</sub>	High Level Input Voltage (DIR, G inputs)	2.0		1.5			1.5		1.5		V	
		4.5		3.15			3.15		3.15			
		6.0		4.2			4.2		4.2			
V <sub>IL</sub>	Low Level Input Voltage (DIR, G inputs)	2.0				0.5		0.5		0.5	V	
		4.5				1.35		1.35		1.35		
		6.0				1.8		1.8		1.8		
V <sub>OH</sub>	High Level Output Voltage	2.0	V <sub>I</sub> = V <sub>IH</sub> or V <sub>IL</sub>	I <sub>O</sub> = -20 μA	1.9	2.0		1.9		1.9	V	
		4.5			4.4	4.5		4.4		4.4		
		6.0			5.9	6.0		5.9		5.9		
		4.5	I <sub>O</sub> = -6.0 mA	4.18	4.31		4.13		4.10			
		6.0		I <sub>O</sub> = -7.8 mA	5.68	5.8		5.63		5.60		
V <sub>OL</sub>	Low Level Output Voltage	2.0	V <sub>I</sub> = V <sub>IH</sub> or V <sub>IL</sub>	I <sub>O</sub> = 20 μA		0.0	0.1		0.1		0.1	V
		4.5				0.0	0.1		0.1		0.1	
		6.0				0.0	0.1		0.1		0.1	
		4.5		I <sub>O</sub> = 6.0 mA		0.17	0.26		0.33		0.40	
		6.0			I <sub>O</sub> = 7.8 mA		0.18	0.26		0.33		
I <sub>I</sub>	Input Leakage Current	6.0	V <sub>I</sub> = V <sub>CC</sub> or GND			±0.1		±1		±1	μA	
I <sub>OZ</sub>	Quiescent Supply Current	6.0	V <sub>I</sub> = V <sub>CC</sub> or GND			æ0.5		±5		±1	μA	
I <sub>CC</sub>	Quiescent Supply Current	6.0	V <sub>I</sub> = V <sub>CC</sub> or GND			4		40		80	μA	

AC ELECTRICAL CHARACTERISTICS (C<sub>L</sub> = 50 pF, Input t<sub>r</sub> = t<sub>f</sub> = 6 ns)

Symbol	Parameter	Test Conditions		Value						Unit	
		V <sub>CC</sub> (V)		T <sub>A</sub> = 25 °C 54HC and 74HC			-40 to 85 °C 74HC		-55 to 125 °C 54HC		
				Min.	Typ.	Max.	Min.	Max.	Min.		Max.
t <sub>TLH</sub> t <sub>THL</sub>	Output Transition Time	2.0			25	60		75		90	ns
		4.5			7	12		15		18	
		6.0			6	10		13		15	
t <sub>PLH</sub> t <sub>PHL</sub>	Propagation Delay Time	2.0			61	125		156		190	ns
		4.5			15	25		31		38	
		6.0			13	21		27		32	
t <sub>PZL</sub> t <sub>PZH</sub>	Output Enable Time	2.0	R <sub>L</sub> = 1 KΩ		77	150		188		225	ns
		4.5			19	30		38		45	
		6.0			16	26		32		38	
t <sub>PLZ</sub> t <sub>PHZ</sub>	Output Disable Time	2.0	R <sub>L</sub> = 1 KΩ		84	150		188		225	ns
		4.5			21	30		38		45	
		6.0			18	26		32		38	
C <sub>IN</sub>	Input Capacitance				5	10		10		10	pF
C <sub>OUT</sub>	Output Capacitance										pF
C <sub>PD</sub> (*)	Power Dissipation Capacitance										pF

(\*) C<sub>PD</sub> is defined as the value of the IC's internal equivalent capacitance which is calculated from the operating current consumption without load. (Refer to Test Circuit). Average operating current can be obtained by the following equation. I<sub>CC(opr)</sub> = C<sub>PD</sub> • V<sub>CC</sub> • f<sub>IN</sub> + I<sub>CC</sub>/4 (per Gate)

SWITCHING CHARACTERISTICS TEST WAVEFORM

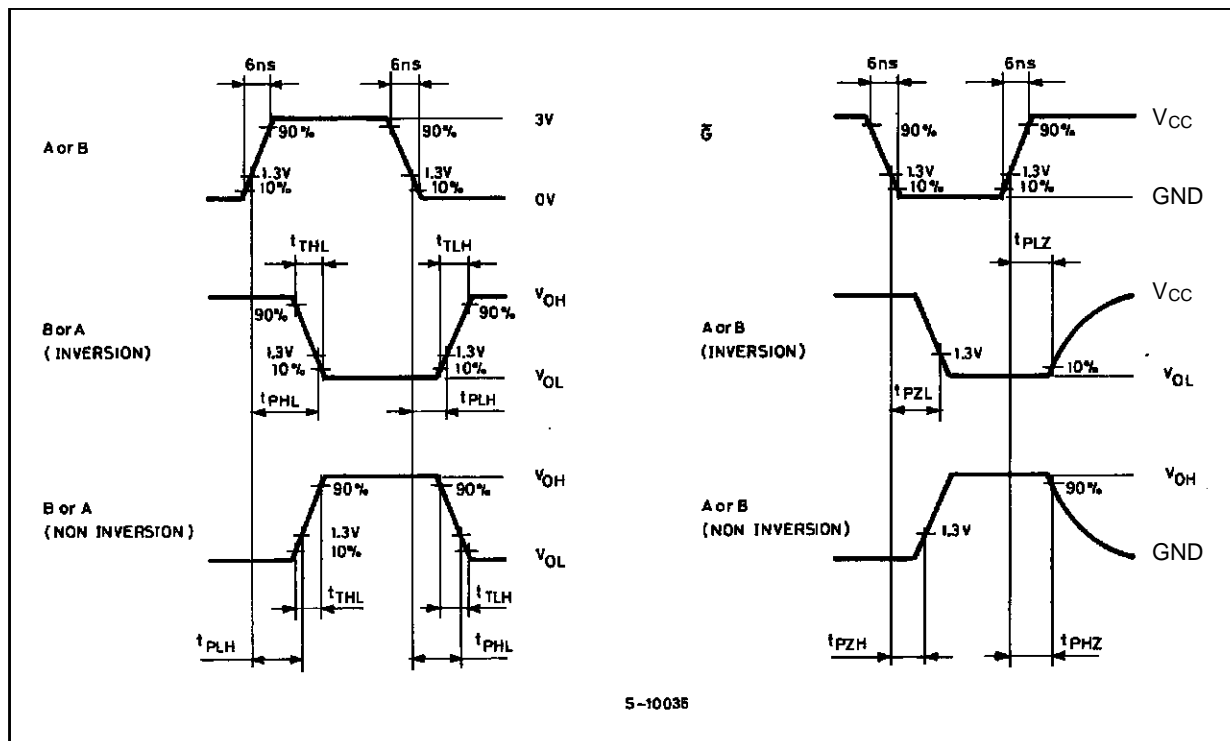

**Plastic DIP20 (0.25) MECHANICAL DATA**

DIM.	mm			inch		
	MIN.	TYP.	MAX.	MIN.	TYP.	MAX.
a1	0.254			0.010		
B	1.39		1.65	0.055		0.065
b		0.45			0.018	
b1		0.25			0.010	
D			25.4			1.000
E		8.5			0.335	
e		2.54			0.100	
e3		22.86			0.900	
F			7.1			0.280
I			3.93			0.155
L		3.3			0.130	
Z			1.34			0.053

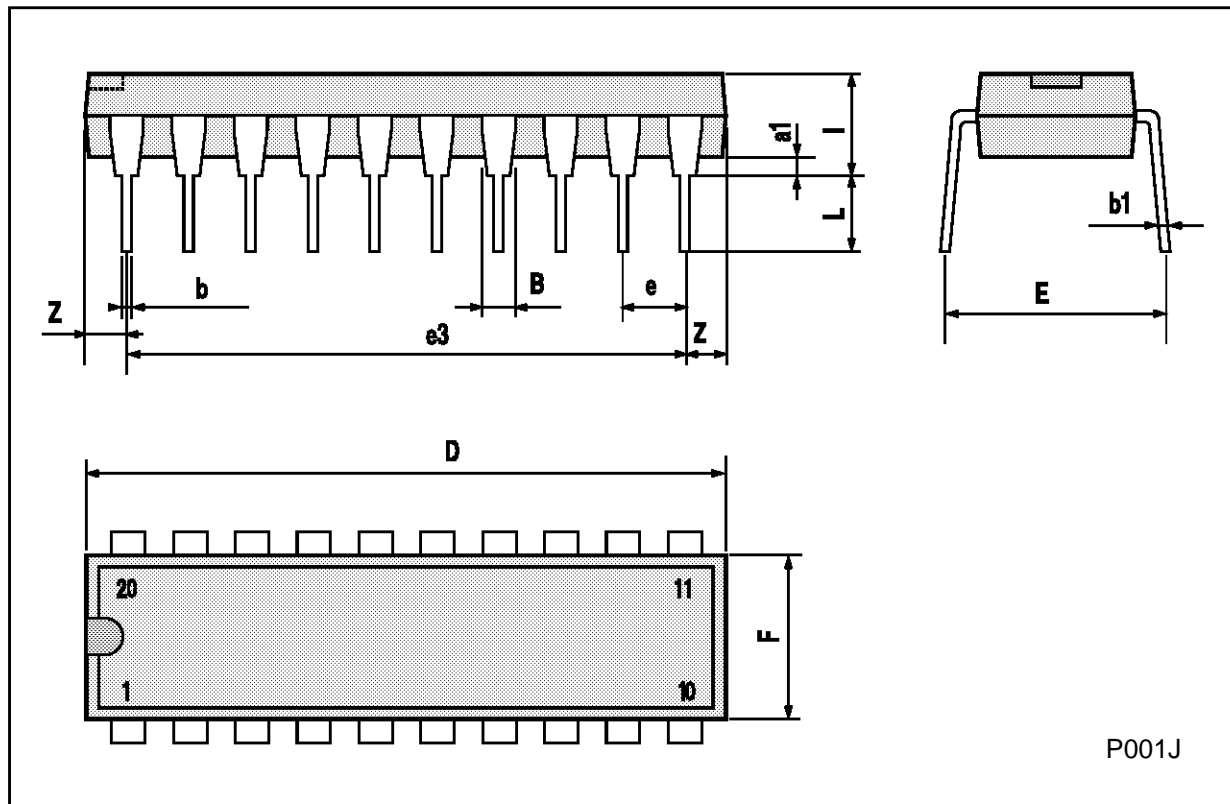

**Ceramic DIP20 MECHANICAL DATA**

DIM.	mm			inch		
	MIN.	TYP.	MAX.	MIN.	TYP.	MAX.
A			25			0.984
B			7.8			0.307
D		3.3			0.130	
E	0.5		1.78	0.020		0.070
e3		22.86			0.900	
F	2.29		2.79	0.090		0.110
G	0.4		0.55	0.016		0.022
I	1.27		1.52	0.050		0.060
L	0.22		0.31	0.009		0.012
M	0.51		1.27	0.020		0.050
N1	4° (min.), 15° (max.)					
P	7.9		8.13	0.311		0.320
Q			5.71			0.225

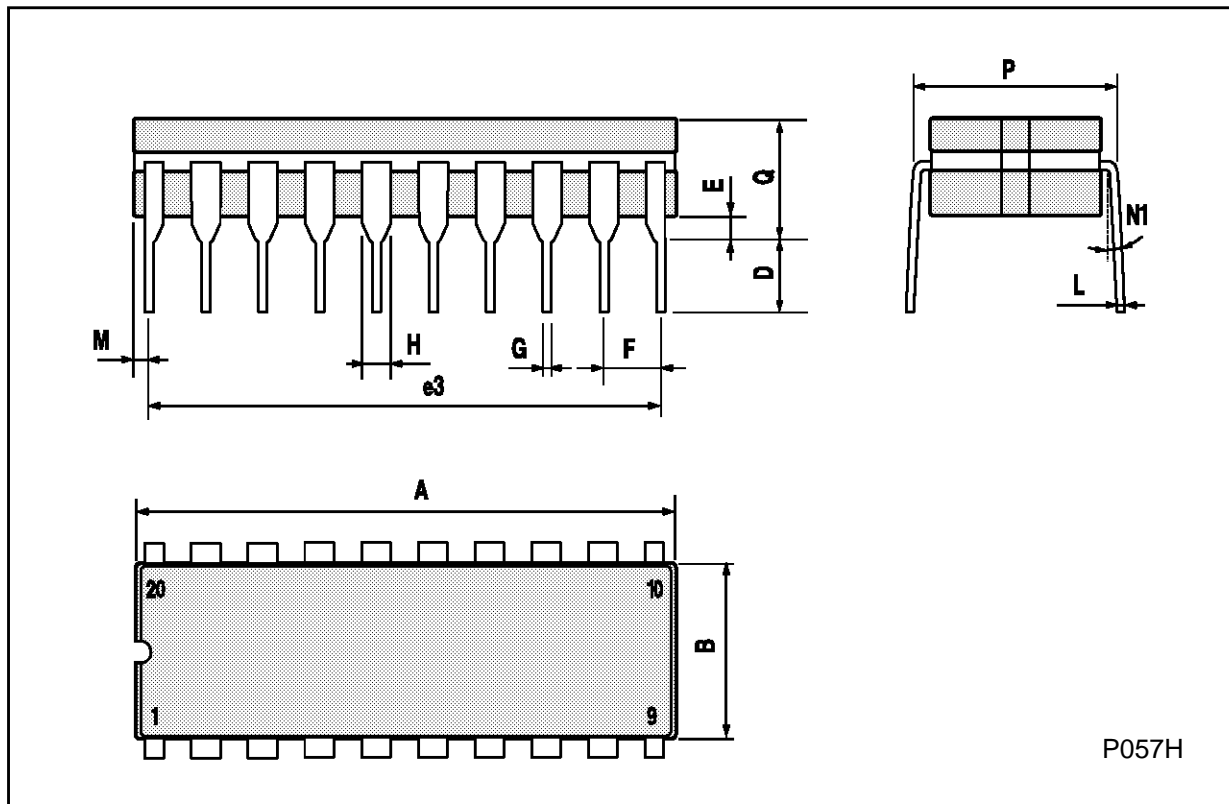

**SO20 MECHANICAL DATA**

DIM.	mm			inch		
	MIN.	TYP.	MAX.	MIN.	TYP.	MAX.
A			2.65			0.104
a1	0.10		0.20	0.004		0.007
a2			2.45			0.096
b	0.35		0.49	0.013		0.019
b1	0.23		0.32	0.009		0.012
C		0.50			0.020	
c1	45° (typ.)					
D	12.60		13.00	0.496		0.512
E	10.00		10.65	0.393		0.419
e		1.27			0.050	
e3		11.43			0.450	
F	7.40		7.60	0.291		0.299
L	0.50		1.27	0.19		0.050
M			0.75			0.029
S	8° (max.)					

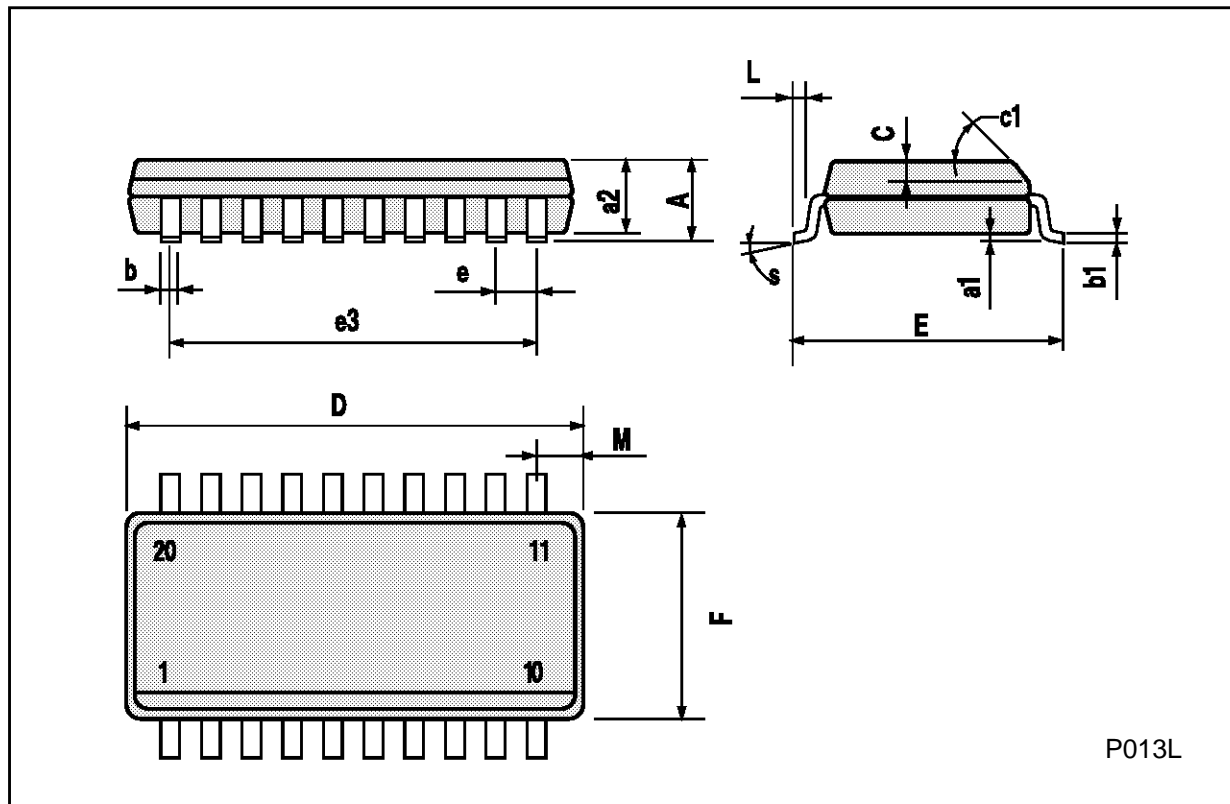

P013L



**PLCC20 MECHANICAL DATA**

DIM.	mm			inch		
	MIN.	TYP.	MAX.	MIN.	TYP.	MAX.
A	9.78		10.03	0.385		0.395
B	8.89		9.04	0.350		0.356
D	4.2		4.57	0.165		0.180
d1		2.54			0.100	
d2		0.56			0.022	
E	7.37		8.38	0.290		0.330
e		1.27			0.050	
e3		5.08			0.200	
F		0.38			0.015	
G			0.101			0.004
M		1.27			0.050	
M1		1.14			0.045	

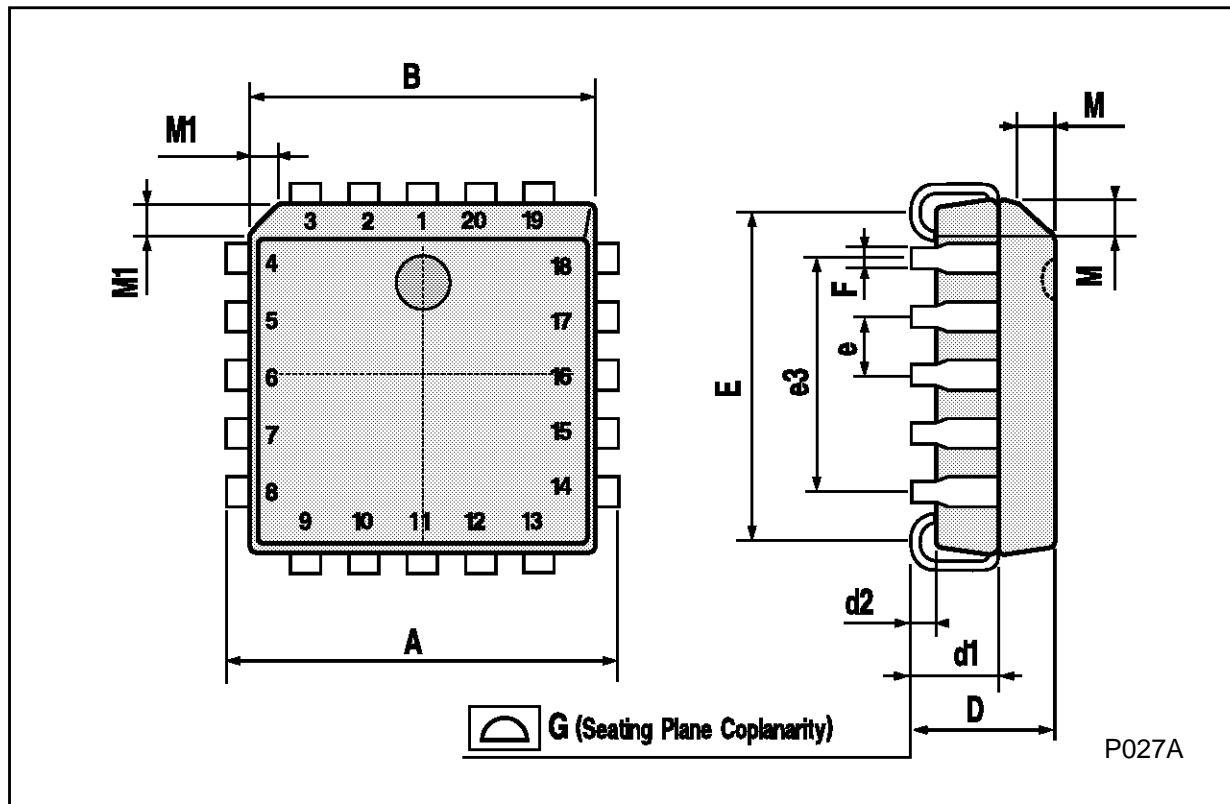

Information furnished is believed to be accurate and reliable. However, SGS-THOMSON Microelectronics assumes no responsibility for the consequences of use of such information nor for any infringement of patents or other rights of third parties which may result from its use. No license is granted by implication or otherwise under any patent or patent rights of SGS-THOMSON Microelectronics. Specifications mentioned in this publication are subject to change without notice. This publication supersedes and replaces all information previously supplied. SGS-THOMSON Microelectronics products are not authorized for use as critical components in life support devices or systems without express written approval of SGS-THOMSON Microelectronics.

© 1994 SGS-THOMSON Microelectronics - All Rights Reserved

SGS-THOMSON Microelectronics GROUP OF COMPANIES  
Australia - Brazil - France - Germany - Hong Kong - Italy - Japan - Korea - Malaysia - Malta - Morocco - The Netherlands -  
Singapore - Spain - Sweden - Switzerland - Taiwan - Thailand - United Kingdom - U.S.A