

M56759FP/AFP

4-CHANNEL ACTUATOR DRIVER

DESCRIPTION

The M56759 is a semiconductor integrated circuit designed for a CD-ROM actuator driver. This device can function 4-channel-actuators by 1 chip due to include 4 channel BTL drivers.

Three channels of this device, ch1, ch2 and ch3 can be controlled by PWM pulse. Two of them, ch1 and ch2 can also act in the Current Control mode.

Furthermore, this device includes two mute circuits and TSD function.

FEATURES

- Low saturation voltage (at bootstrap).
- (typical 0.7V at load current 500mA)
- Wide supply voltage range. (4.5V to 13.2V)
- Low cross-over distortion.
- Two naked Operational Amplifiers
- Divided Motor power supplies into three parts

APPLICATION

CD-ROM

PIN CONFIGURATION (TOP VIEW)

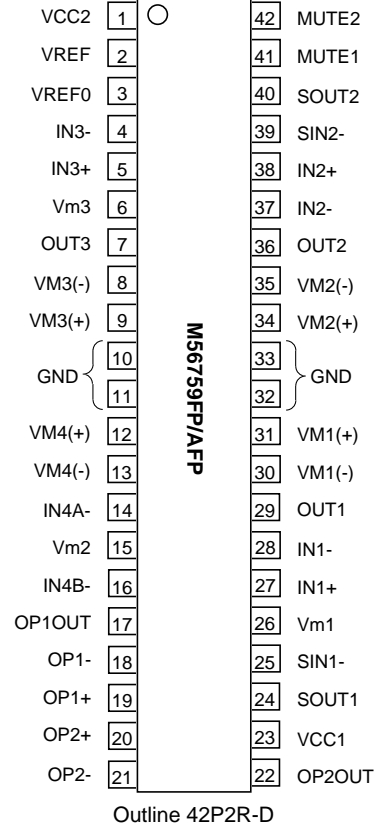

BLOCK DIAGRAM

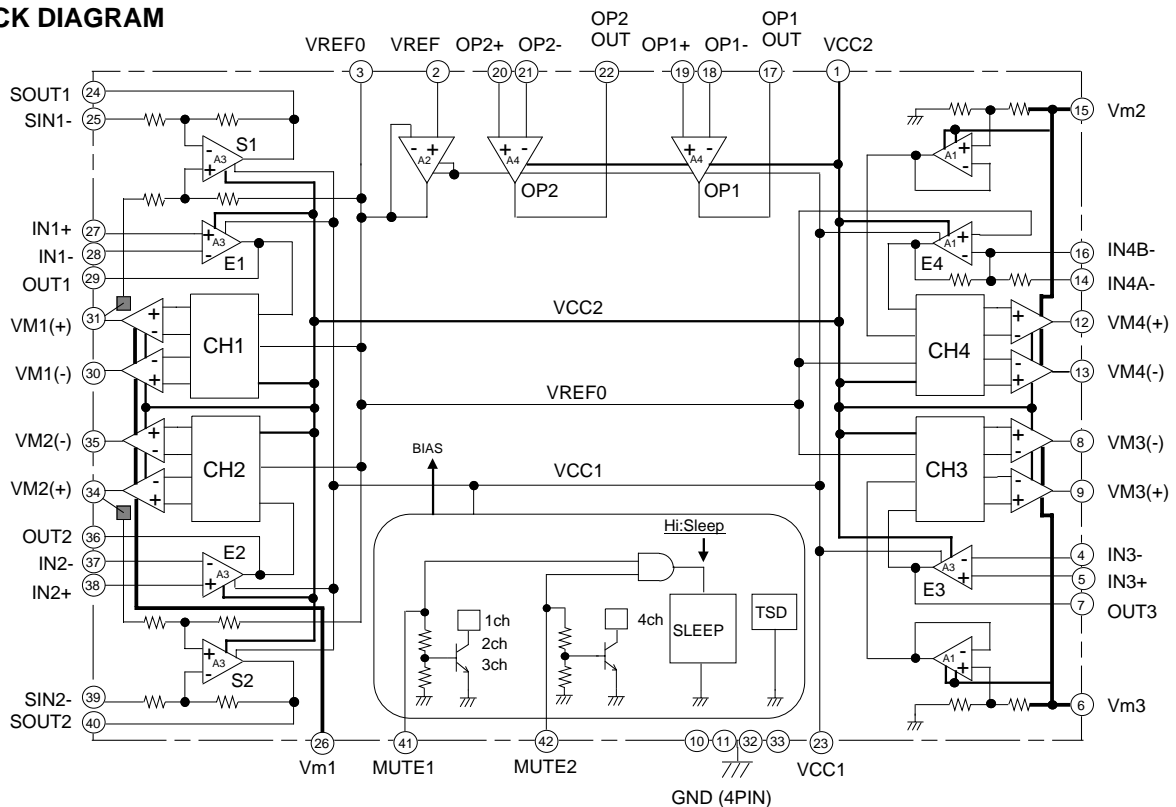

PIN DESCRIPTIONS

Pin No.	Symbol	Function	Pin No.	Symbol	Function
①	VCC2	Bootstrap power supply	②②	OP2OUT	OP2 amplifier output
②	VREF	Reference voltage input	②③	VCC1	5V power supply
③	VREF0	Reference voltage output	②④	SOUT1	S1 amplifier output
④	IN3-	E3 amplifier inverted input	②⑤	SIN1-	S1 amplifier inverted input
⑤	IN3+	E3 amplifier non-inverted input	②⑥	Vm1	Motor power supply-1
⑥	Vm3	Motor power supply-3	②⑦	IN1+	E1 amplifier non-inverted input
⑦	OUT3	E3 amplifier output	②⑧	IN1-	E1 amplifier inverted input
⑧	VM3(-)	CH3 inverted output	②⑨	OUT1	E1 amplifier output
⑨	VM3(+)	CH3 non-inverted output	③⑩	VM1(-)	CH1 inverted output
⑩ to ⑪	GND	GND	③①	VM1(+)	CH1 non-inverted output
⑫	VM4(+)	CH4 non-inverted output	③② to ③③	GND	GND
⑬	VM4(-)	CH4 inverted output	③④	VM2(+)	CH2 non-inverted output
⑭	IN4A-	E4 amplifier low gain input	③⑤	VM2(-)	CH2 inverted output
⑮	Vm2	Motor power supply-2	③⑥	OUT2	E2 amplifier output
⑯	IN4B-	E4 amplifier high gain input	③⑦	IN2-	E2 amplifier inverted input
⑰	OP1OUT	OP1 amplifier output	③⑧	IN2+	E2 amplifier non-inverted input
⑱	OP1-	OP1 amplifier inverted input	③⑨	SIN2-	S2 amplifier inverted input
⑲	OP1+	OP1 amplifier non-inverted input	④⑩	SOUT2	S2 amplifier output
⑳	OP2+	OP2 amplifier non-inverted input	④①	MUTE1	CH1, 2 and 3 mute
㉑	OP2-	OP2 amplifier inverted input	④②	MUTE2	CH4 mute

ABSOLUTE MAXIMUM RATINGS (Ta=25°C)

Symbol	Parameter	Conditions	Rating	Unit
VCC2	Bootstrap power supply	① pins input voltage	15	V
Vm	Motor power supply	②⑥, ⑮ and ⑯ pins input voltage	15	V
VCC1	5V power supply	②③ pin input voltage	7.0	V
Io	Output Current		700	mA
Vin1	Maximum input voltage of terminals	②, ④, ⑤, ⑭, ⑯, ⑱, ⑲, ⑳, ㉑, ⑳, ㉑, ㉒, ㉓, ㉔, ㉕, ㉖, ㉗, ㉘, ㉙, ㉚ pins	0 – VCC1	V
Vin2		②⑤, ③⑨ pins	0 – Vm1	
Pt	Power dissipation	Free Air	1.2	W
Kθ	Thermal derating	Free Air	9.6	mW/°C
Tj	Junction temperature		150	°C
Topr	Operating temperature		-20 – +70	°C
Tstg	Storage temperature		-40 – +150	°C

RECOMMENDED OPERATING CONDITIONS

Symbol	Parameter	Limits			Unit
		Min.	Typ.	Max.	
VCC1	5V power supply	4.5	5.0	5.5	V
VCC2	Bootstrap power supply		Vm+1.0		V
Vm1,2,3	Motor power supply-1, 2, 3		5.0		V

ELECTRICAL CHARACTERISTICS

(Ta=25°C, VCC1=Vm1=Vm2=Vm3=5V, VCC2=12V, no-load current unless otherwise noted)

Symbol	Parameter	Conditions	Limits			Unit
			Min.	Typ.	Max.	
ICC1	Supply current-1	①, ⑳, ⑲, ⑥ pins supply current (Vref=Vctl=2.5V)	—	24	36	mA
ICC2	Supply current-2	⑳ pins[VCC1] supply current (Vref=Vctl=2.5V)	—	9.5	15	mA
ICC3	Sleep Mode Supply current-3	①, ⑳, ⑲, ⑶, ⑥ pins supply current (MUTE1,2=H)	—	—	500	μA
VsatCH1	Ch1 Saturation voltage	Top and Bottom saturation voltage. Load current 500mA. At bootstrap.	—	0.8	1.20	V
VsatCH2	Ch2 Saturation voltage		—	0.8	1.20	V
VsatCH3	Ch3 Saturation voltage		—	0.5	0.9	V
VsatCH4	Ch4 Saturation voltage		—	0.6	1.0	V
Vmute-on	Mute-on voltage	Mute-on	2.0	—	—	V
Vmute-off	Mute-off voltage	Mute-off	—	—	0.8	V
Imute	Mute terminals input current	④ and ④ pin input current at 5V input voltage.	—	170	250	μA
VinOP	OP1 and OP2 amplifier Input voltage range		0.5	—	VCC2-1.0	V
VoutOP	OP1 and OP2 amplifier output voltage range	Io=±2.0mA	0.5	—	VCC1-0.5	V
VofOP	OP1 and OP2 amplifier input offset voltage	Vin=2.5V (at buffer)	-10	—	+10	mV
IinOP	OP1 and OP2 amplifier input current	inverted input = non-inverted input = 2.5V	-1.0	-0.15	0	μA
IofOP	OP1 and OP2 amplifier input current offset	inverted input = non-inverted input = 2.5V	-100	0	+100	nA
GBOP	OP1 and OP2 amplifier GB		2.3	4	—	MHz
VinE	E1,E2 and E3 amplifier Input voltage range		0.5	—	VCC2-2.0	V
VoutE	E1,E2 and E3 amplifier output voltage range	No load	1.0	—	VCC1-0.5	V
VofE	E1,E2 and E3 amplifier input offset voltage	Vin=2.5V (at buffer)	-10	—	+10	mV
IinE	E1,E2 and E3 amplifier input current	inverted input = non-inverted input = 2.5V	-1.0	-0.15	0	μA
IofE	E1,E2 and E3 amplifier input current offset	inverted input = non-inverted input = 2.5V	-100	0	+100	nA
VoutS	S1 and S2 amplifier output voltage range	No load	1.0	—	VCC1-0.5	V
VinVREF	VREF buffer amplifier Input voltage range		1.5	2.5	VCC1-1.2	V
VofVREF	VREF buffer amplifier offset voltage	② pin input voltage = 2.5V	-10	—	+10	mV
VofCH1	Ch1 output offset voltage	when the OUT1 voltage is adjusted at the same VREFO voltage, at VREF=2.5V	-26	—	+26	mV
VofCH2	Ch2 output offset voltage	when the OUT2 voltage is adjusted at the same VREFO voltage, at VREF=2.5V	-26	—	+26	mV
VofCH3	Ch3 output offset voltage	when the OUT3 voltage is adjusted at the same VREFO voltage, at VREF=2.5V	-26	—	+26	mV
VofCH4	Ch4 output offset voltage	when the IN4- voltage is adjusted at the same VREFO voltage, at VREF=2.5V	-26	—	+26	mV
VofS1	S1 output offset voltage	SOUT1-VREFO (at SI N1[-] = VM1[+]) at VREF=2.5V	-20	—	+20	mV
VofS2	S2 output offset voltage	SOUT2-VREFO (at SI N2[-] = VM2[+]) at VREF=2.5V	-20	—	+20	mV
GainCH1	Ch1 power amplifier voltage gain	$\frac{\{VM1(+)-VM1(-)\}}{(OUT1-VREFO)}$ at VREF=2.5V	13.1	14	14.8	dB
GainCH2	Ch2 power amplifier voltage gain	$\frac{\{VM2(+)-VM2(-)\}}{(OUT2-VREFO)}$ at VREF=2.5V	13.1	14	14.8	dB
GainCH3	Ch3 power amplifier voltage gain	$\frac{\{VM3(+)-VM3(-)\}}{(OUT3-VREFO)}$ at VREF=2.5V	19.1	20	20.8	dB
GainCH4	Ch4 power amplifier voltage gain	$\frac{-1 \cdot \{VM4(+)-VM4(-)\}}{(IN4A[-]-VREFO)}$ at VREF=2.5V	3.17	4.08	4.91	dB
GainS1	S1 amplifier voltage gain	$\frac{\{SOUT1 - VREFO\}}{(VM1[+] - SI N1[-])}$ at VREF=2.5V	5.11	6.02	6.85	dB
GainS2	S2 amplifier voltage gain	$\frac{\{SOUT2 - VREFO\}}{(VM2[+] - SI N2[-])}$ at VREF=2.5V	5.11	6.02	6.85	dB

INPUT and OUTPUT CHARACTERISTICS of EACH CHANNELS

CH1 amplifier

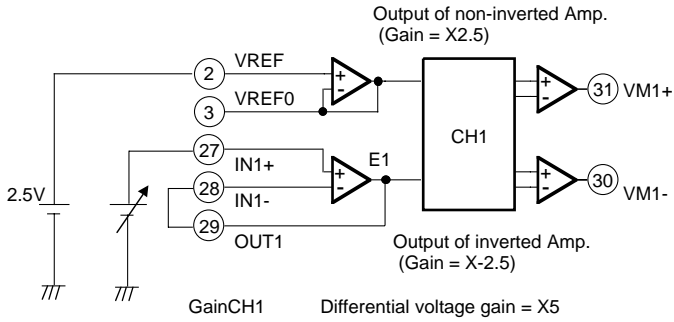

<INPUT>

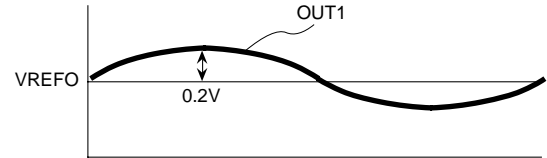

<OUTPUT>

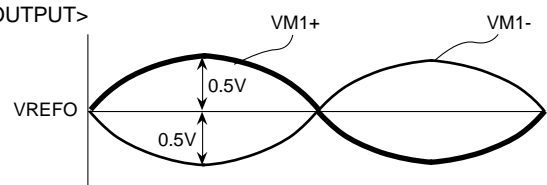

CH2 amplifier

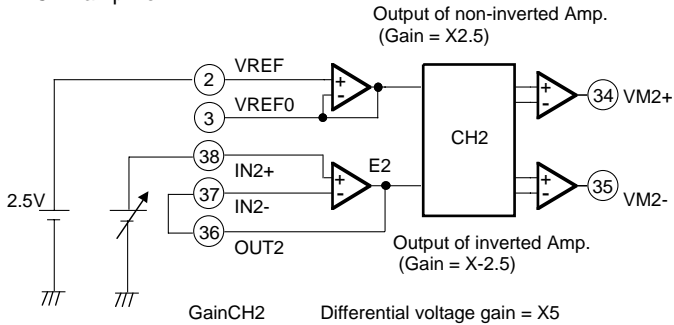

<INPUT>

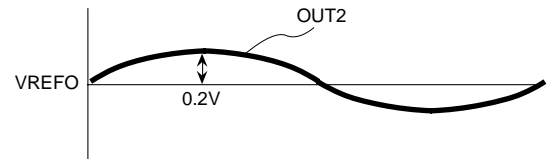

<OUTPUT>

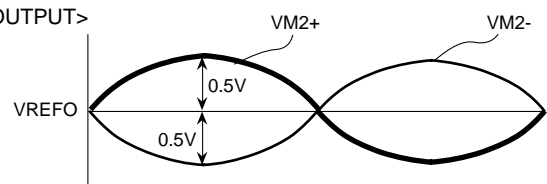

CH3 amplifier

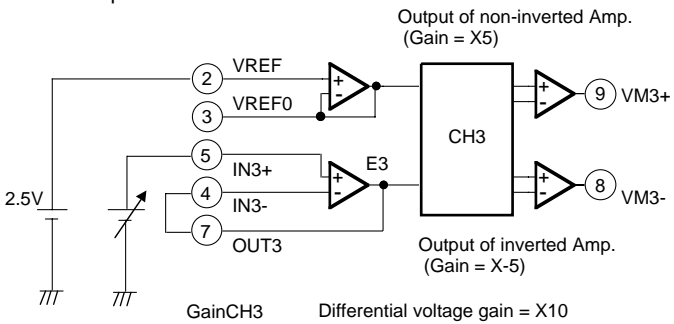

<INPUT>

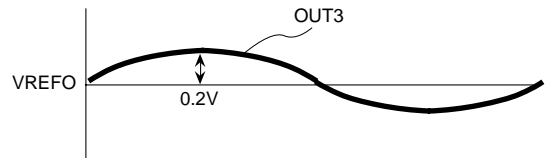

<OUTPUT>

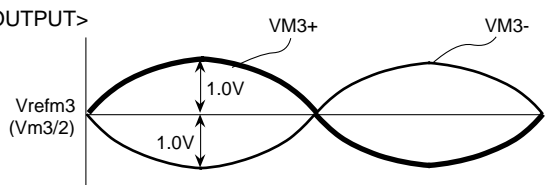

CH4 amplifier

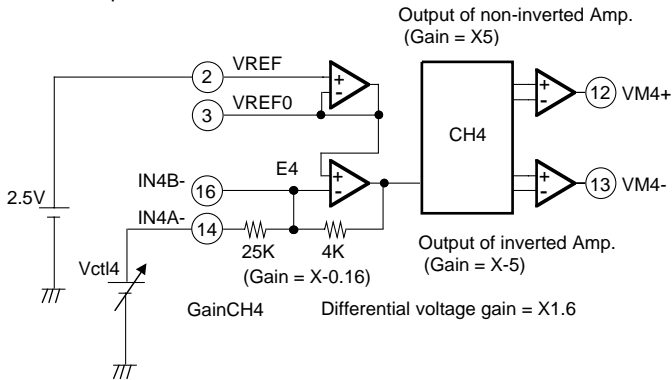

<INPUT>

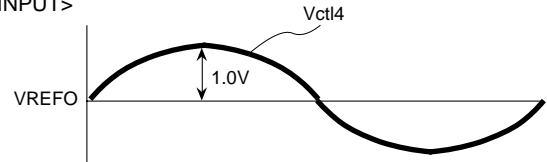

<OUTPUT>

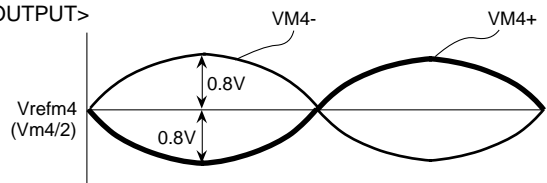

S1 amplifier

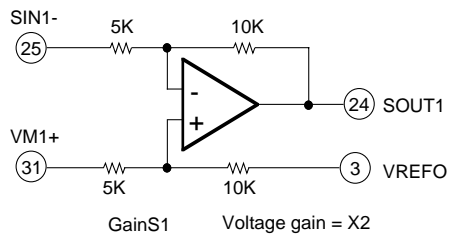

<INPUT>

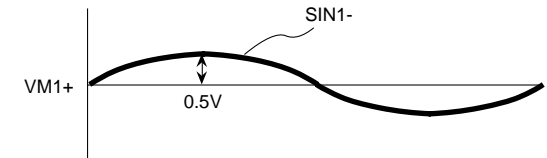

<OUTPUT>

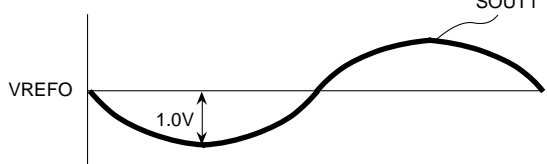

S2 amplifier

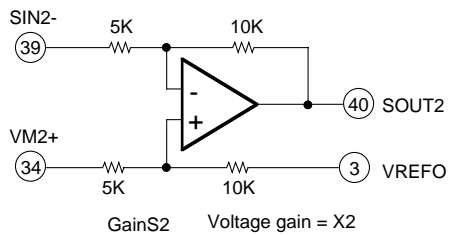

<INPUT>

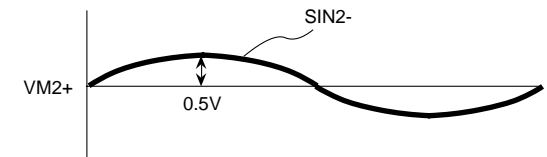

<OUTPUT>

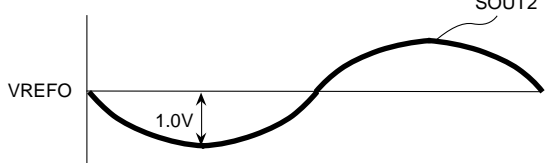

<BASICALLY CHARACTERISTICS>

This data is an example for typical sample.

Output saturation voltage and Load current characteristic.

BOOTSTRAP

CH1

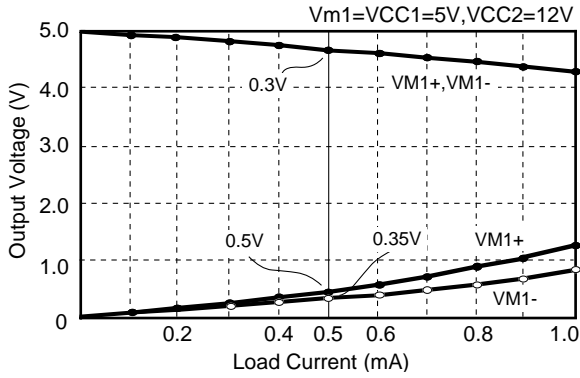

CH2

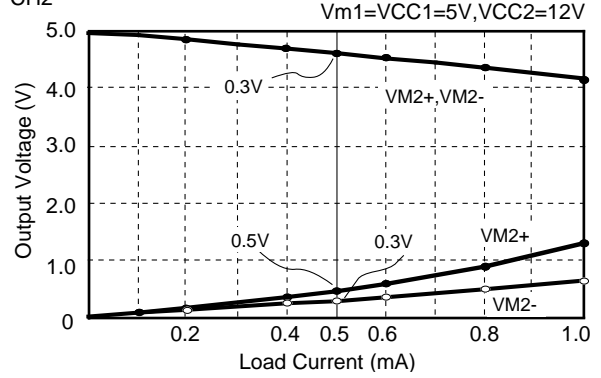

CH3

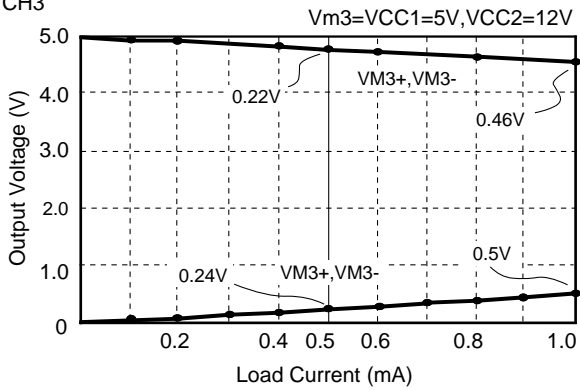

CH4

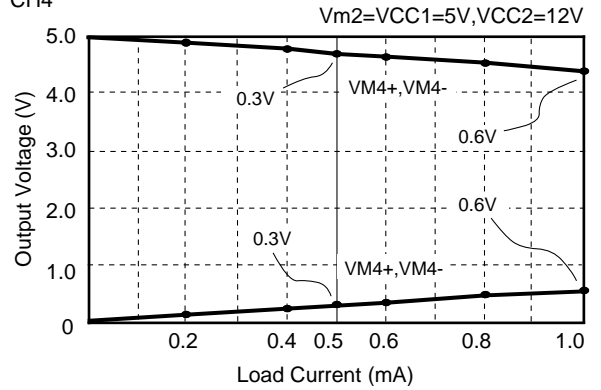

NON-BOOTSTRAP

CH1

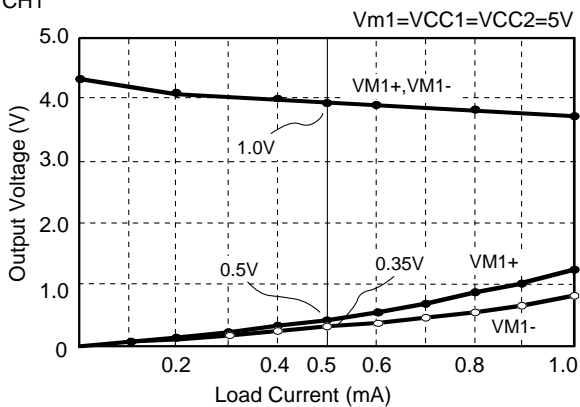

CH2

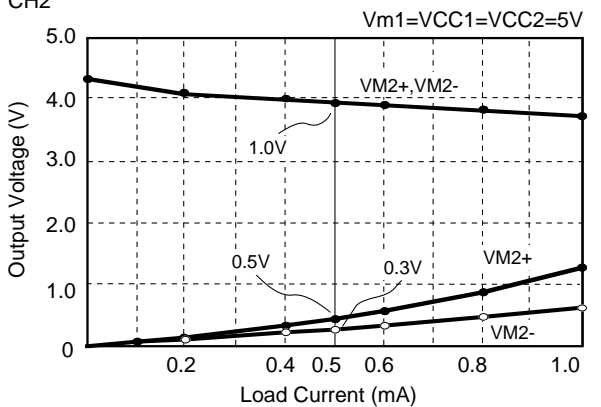

CH3

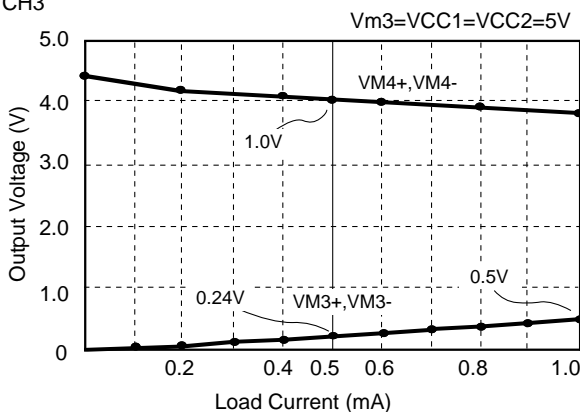

CH4

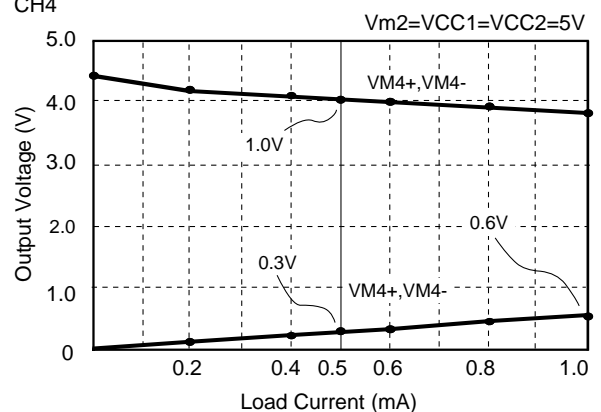

THERMAL DERATING

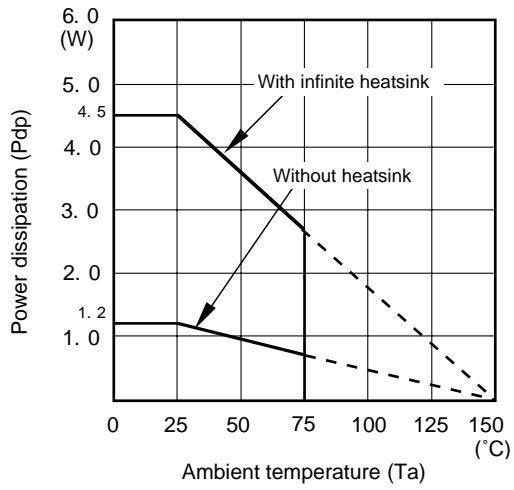

M56759FP/AFP

4-CHANNEL ACTUATOR DRIVER

APPLICATION CIRCUIT No.1

- single input (linear signal)
- Direct voltage control

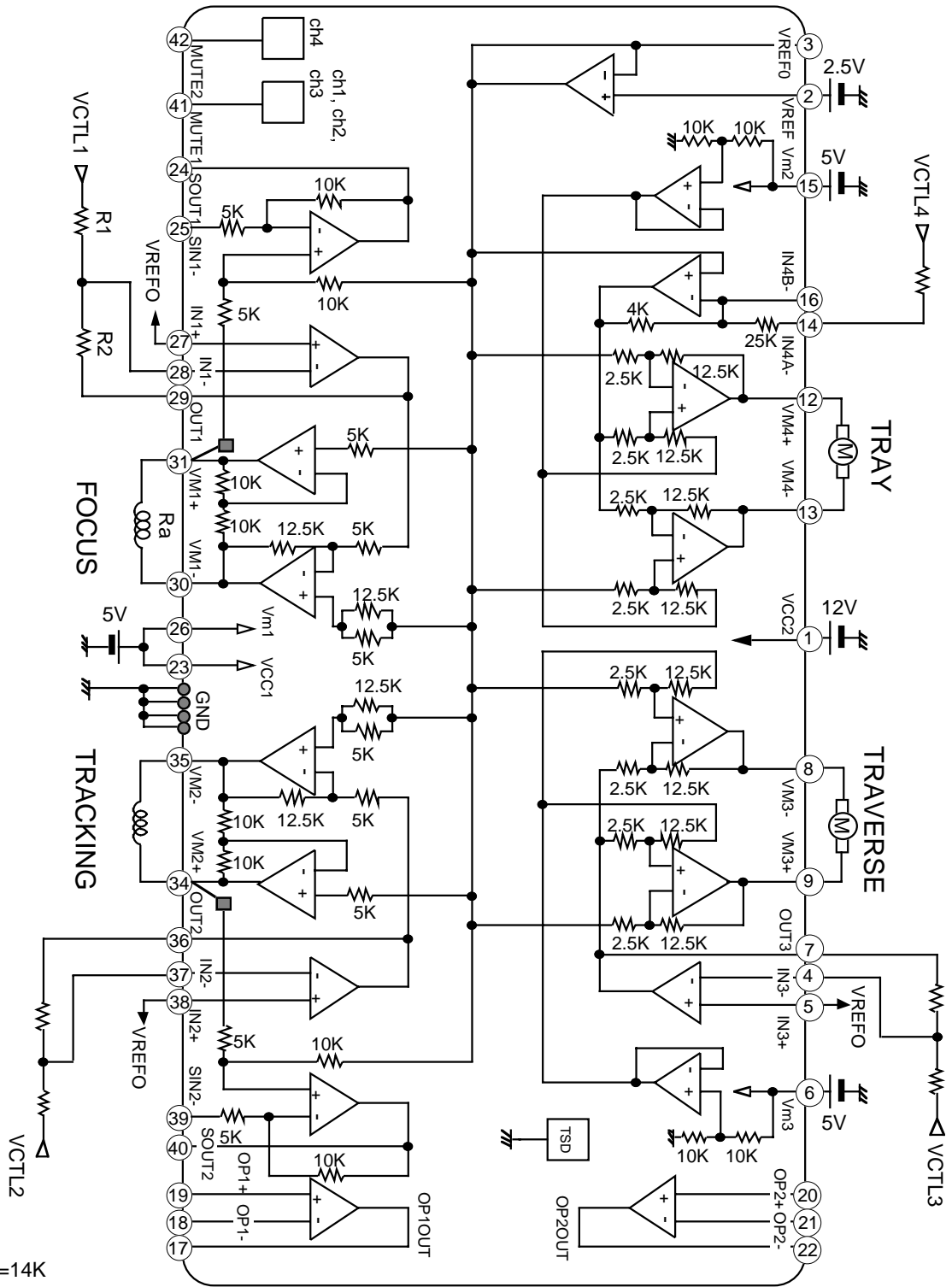

cf. R1=10K,R2=14K

$$\begin{aligned} \text{Voltage gain} &= \text{GainCH1} \cdot R2 / R1 \\ &= 5 \cdot 14 / 10 \\ &= 7 \text{ (V/V)} = 16.9\text{dB} \end{aligned}$$

if. Ra=10

$$\text{Current gain} = 7/10 = 0.7 \text{ (A/V)}$$

M56759FP/AFP

4-CHANNEL ACTUATOR DRIVER

APPLICATION CIRCUIT No.2

- single input (linear signal)
- Direct current control (for FOCUS and TRACKING)

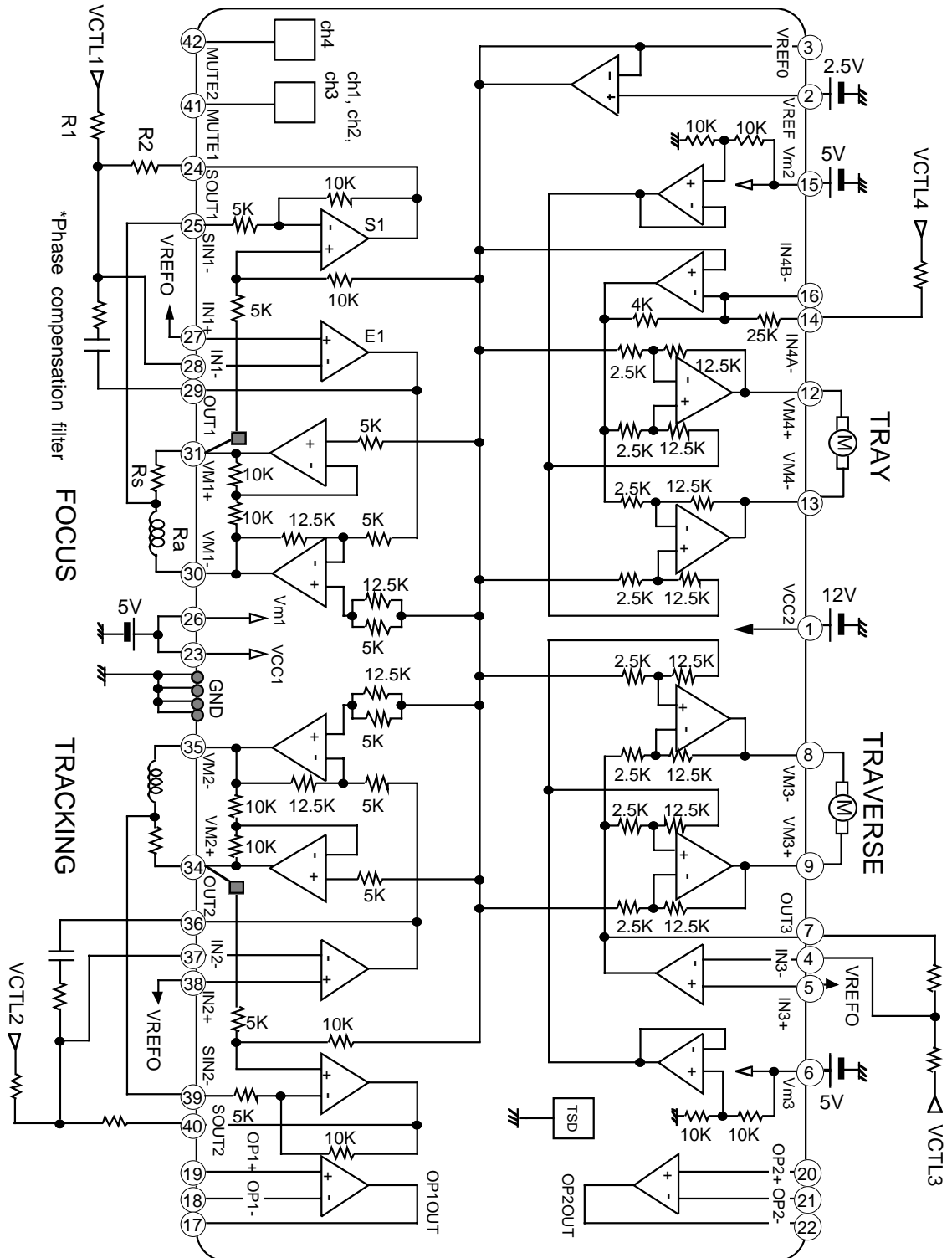

cf. R1=10K,R2=14K,RS=1
 Current gain = $R2 / [R1 \cdot \text{GainS1} \cdot \text{Rs}]$
 = $14 / [10 \cdot 2 \cdot 1]$
 = 0.7 (A/V)

M56759FP/AFP

4-CHANNEL ACTUATOR DRIVER

APPLICATION CIRCUIT No.3

- Differential PWM input (for FOCUS, TRACKING and TRAVERSE)
- Direct voltage control

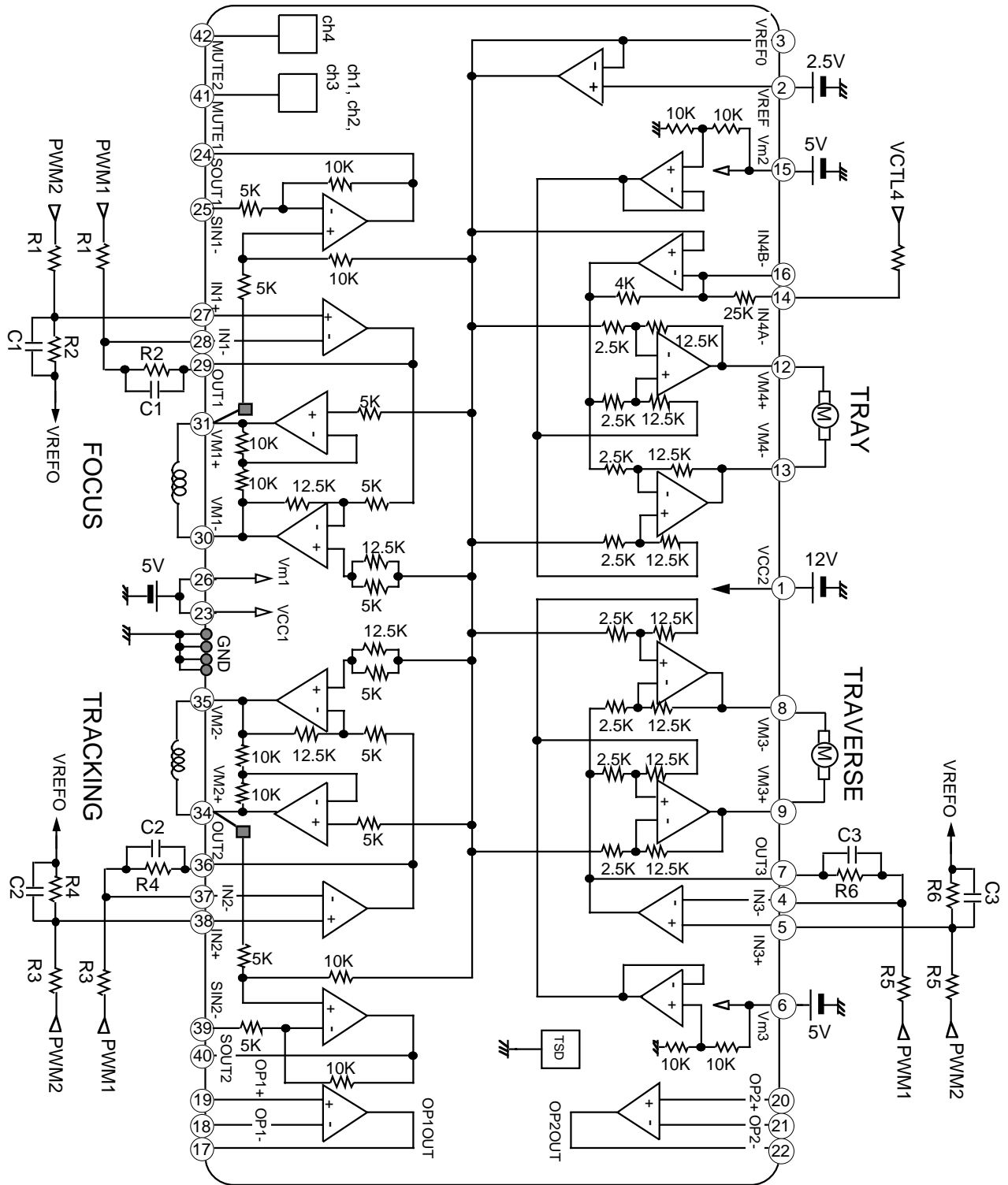

M56759FP/AFP

4-CHANNEL ACTUATOR DRIVER

APPLICATION CIRCUIT No.4

- Differential PWM input (for FOCUS, TRACKING and TRAVERSE)
- Direct current control (for FOCUS and TRACKING)

