

# M61524FP

## 2ch ELECTRONIC VOLUME WITH 4 INPUT SELECTOR

REJ03F0035-0100Z

Rev.1.0

Sep.19.2003

### Features

Function	FEATURES
Input selector	4input selector MUTE
Input gain control	0,+3,+6,+9dB
Karaoke mode	Stereo, Lch mono, Rch mono, Vocal cut
MIC MIX	Mixing before the output of REC MIC amp:+6dB, With the MIC SWs
REC Output	LRch each one output
Surround	With the ON/OFF SWs
Main Volume	0 -90dB, -∞/1dB step <ul style="list-style-type: none"><li>• A volume 0 to -24dB/1dB step</li><li>• B volume 0 to -66dB, -∞/1dB step</li></ul> Each channel is independence control.
Tone control	(1) Bass -8 +14dB/2dB step,f0=100Hz (2) Mid:±8dB/2dB step,f0=1KHz (3) Treble: ±8dB/2dB step,f0=10KHz Add a Bypass Mode/Tone Mode changing SWs
Bass boost	High Pass Filter Type
Microcomputer Interface	2 line serial data control .

### Application

Mini Stereo, etc.

### Recommended Operating Condition

Rated Supply voltage .....VCC = 9.0V (typ)

System Configuration

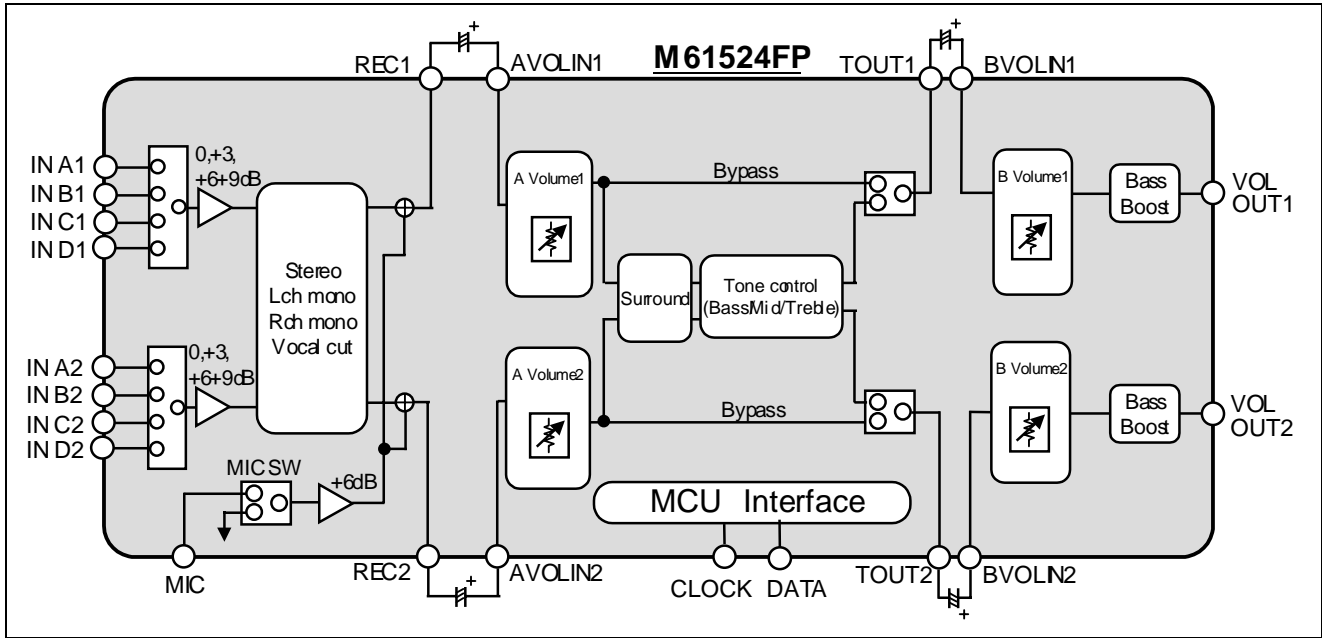

Block Diagram and Pin Configuration (Top View)

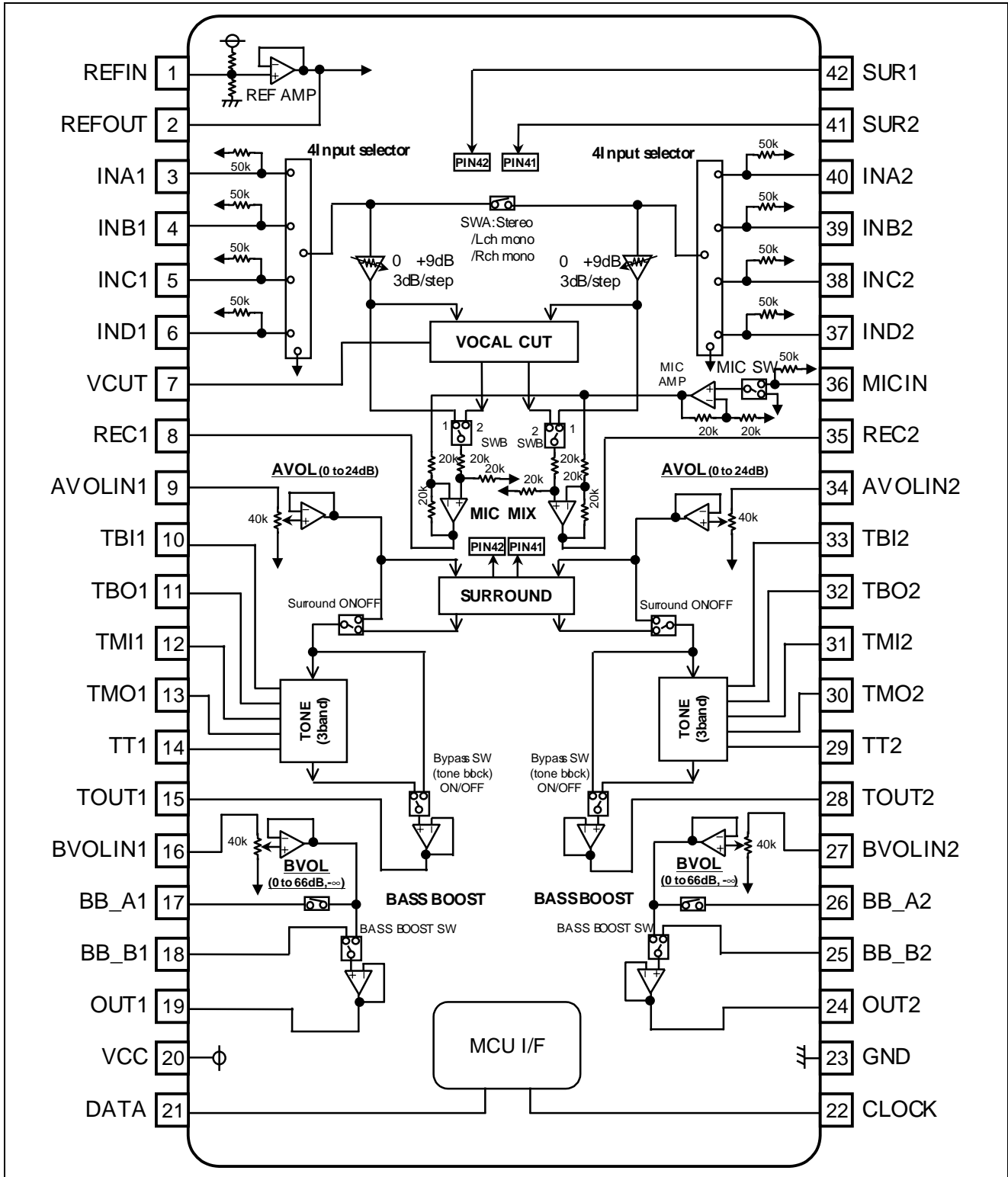

**Pin Description**

<b>Pin No.</b>	<b>Terminal name</b>	<b>Function</b>
1	REFIN	Input pin of reference Amp
2	REFOUT	Output pin of reference Amp
3,4,5,6, 37,38,39,40	INA~IND	Input pin of input selector (Ch1 and Ch2)
7	VCUT	Frequency characteristic setting pin of vocal cut
8,35	REC	Output pin of REC (Ch1 and Ch2)
9,34	AVOLIN	Input pin of A volume (Ch1 and Ch2)
10,11,12,13,14, 29,30,31,32,33	TBI,TBO,TMI,TMO,TT	Frequency characteristic setting pin of tone control (Bass/Mid/Treble)
15,28	TOUT	Output pin of tone (Ch1 and Ch2)
16,27	BVOLIN	Input pin of B volume (Ch1 and Ch2)
17,18,25,26	BB_A,BB_B	Frequency characteristic setting pin of bass boost
19,24	OUT	Output pin (Ch1 and Ch2)
20	VCC	The power supply
21	DATA	Input pin of Control Trigger (DATA)
22	CLOCK	Input pin of Control Trigger (CLOCK)
23	GND	GND
36	MICIN	Input pin of MIC AMP
41,42	SUR	Frequency characteristic setting pin of Surround

## Absolute Maximum Ratings

( $T_a=25^\circ\text{C}$ , unless otherwise noted)

Symbol	Parameter	Conditions	Limits	Units
Power supply	VCC		10.5	V
$P_d$	Power dissipation	$T_a \leq 25^\circ\text{C}$	850	mW
K	Thermal derating	$T_a > 25^\circ\text{C}$	8.6	mW/ $^\circ\text{C}$
$T_{opr}$	Operating temperature		-20 to +75	$^\circ\text{C}$
$T_{stg}$	Storage temperature		-40 to +125	$^\circ\text{C}$

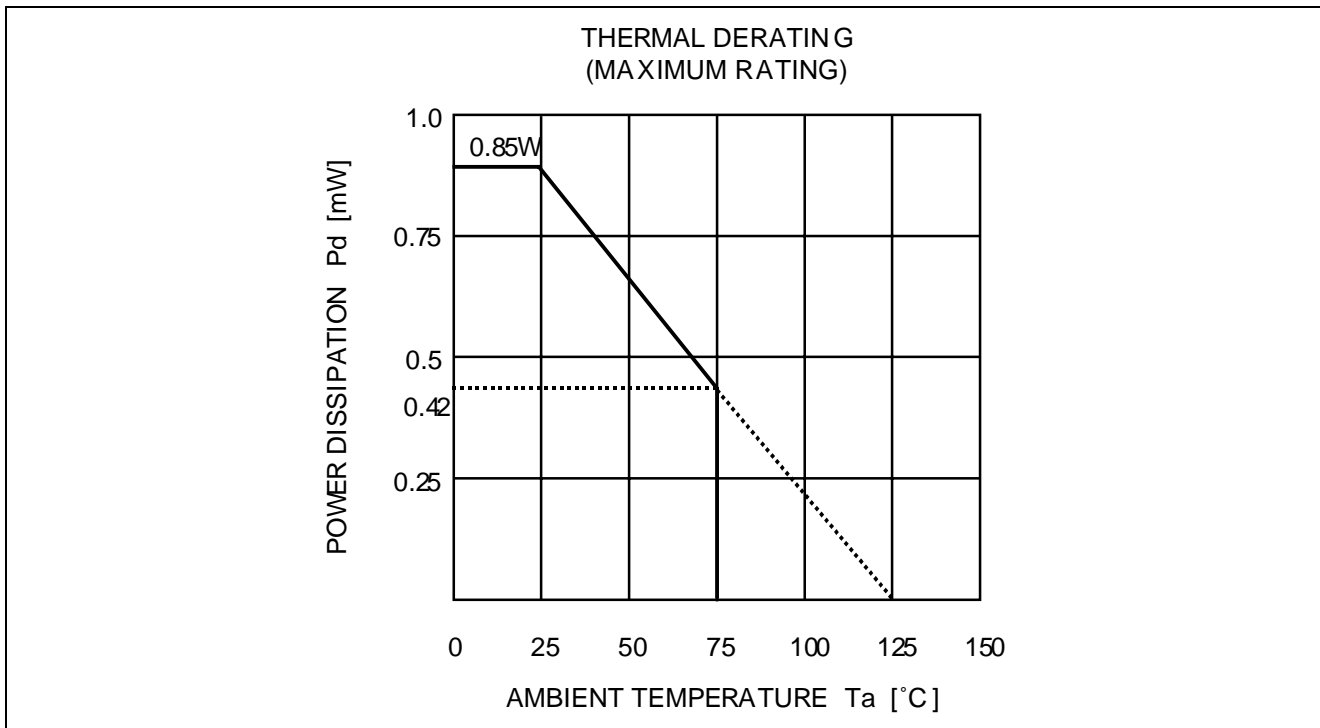

**Recommended Operating Condition**

(Ta=25°C, unless otherwise noted)

Parameter	Symbol	Conditions	Limits			Units
			MIN	TYP	MAX	
Supply voltage	VCC		8	9	10	V
Logic "H" level input voltage	VIH	VCC=9V GND reference	2.2	—	5.5	V
Logic "L" level input voltage	VIL	VCC=9V GND reference	0	—	0.6	V

**Relationship between Data and Clock**

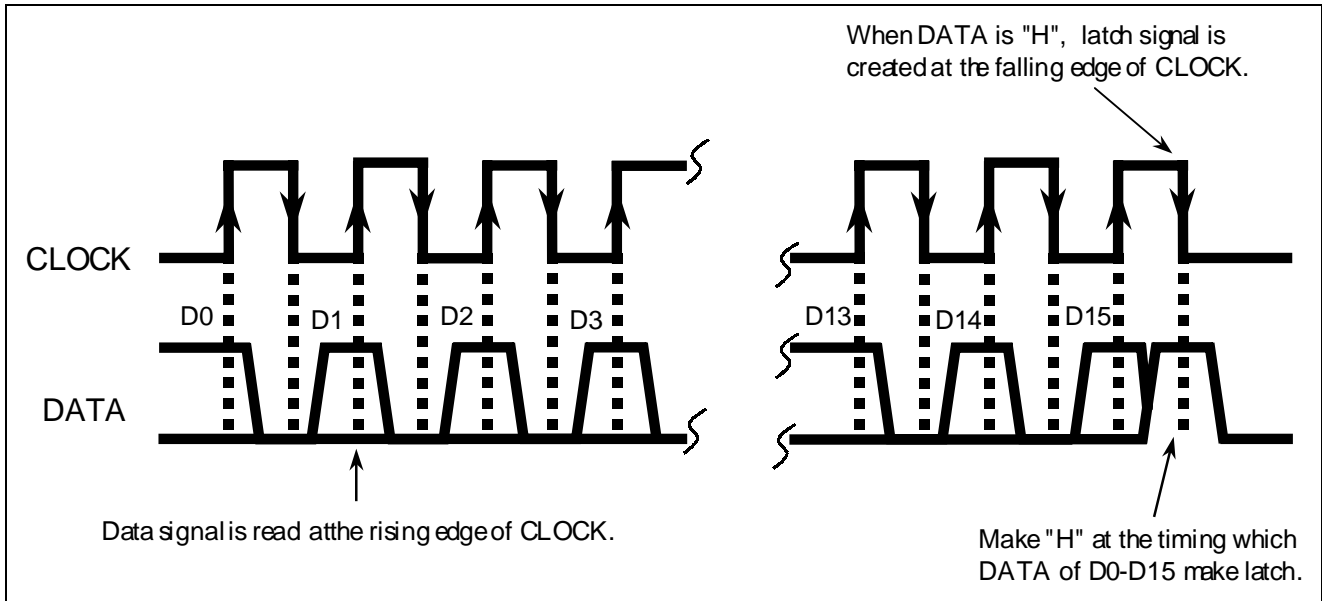

## Clock and Data Timings

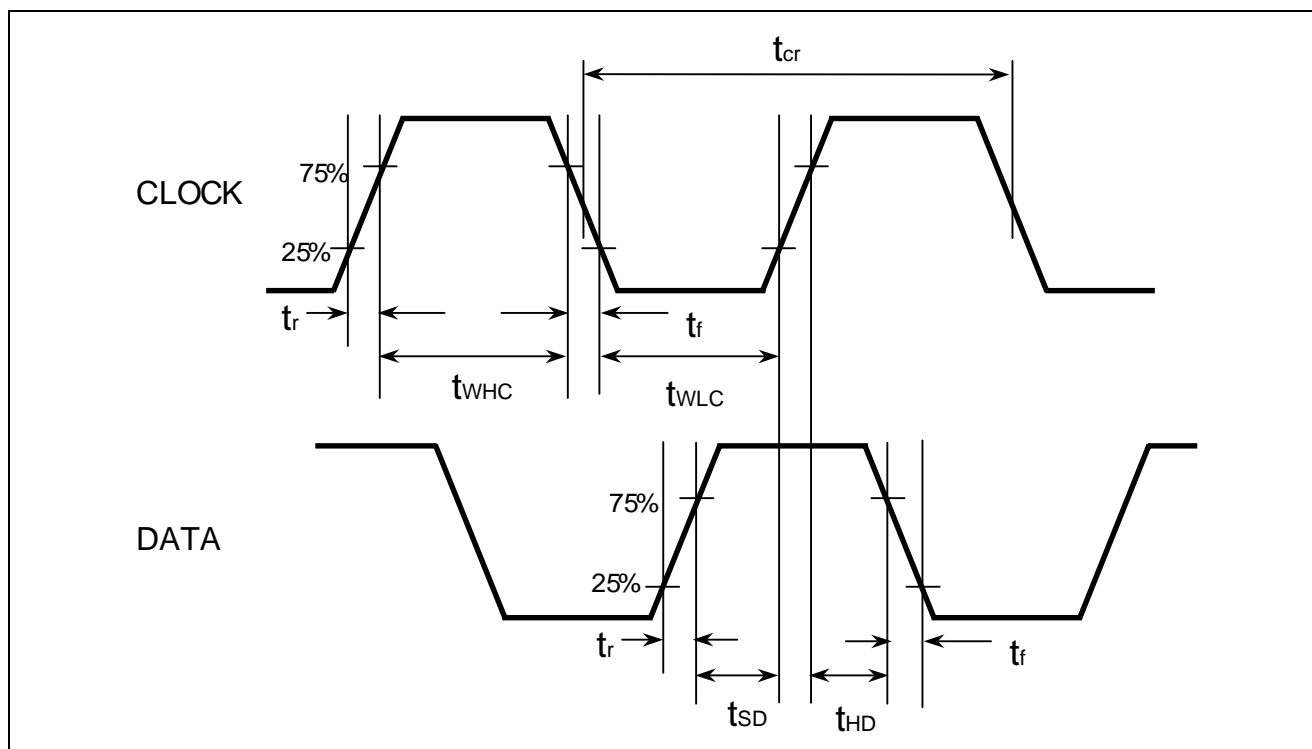

## Timing Definition of Digital Block

Symbol	Parameter	Limits			Units
		MIN	TYP	MAX	
$t_{cr}$	CLOCK cycle time	4	—	—	$\mu\text{S}$
$t_{WHC}$	CLOCK pulse width ("H" level)	1.6	—	—	
$t_{WLC}$	CLOCK pulse width ("L" level)	1.6	—	—	
$t_r$	Rising time of clock and data	—	—	0.4	
$t_f$	Falling time of clock and data	—	—	0.4	
$t_{SD}$	DATA setup time	0.8	—	—	
$t_{HD}$	DATA hold time	0.8	—	—	

## Data Control Specification

Four types of input format can be selected by changing the D14/D15 slot setting status.

(Initialize all data of the 4 formats when power supply(VCC) turn on.)

(1)	D0a	D1a	D2a	D3a	D4a	D5a	D6a	D7a	D8a	D9a	D10a	D11a	D12a	D13a	D14a	D15a
	1. Input selector			2. Karaoke mode control		3. Input gain control		4. Surround	5. MIC SW	0	0	0	0	0	0	0

(2)	D0b	D1b	D2b	D3b	D4b	D5b	D6b	D7b	D8b	D9b	D10b	D11b	D12b	D13b	D14b	D15b
	6. Tone control Bass				6. Tone control Mid				6. Tone control Treble				7. Bypass SW (tone block)	8. Bass boost	0	1

(3)	D0c	D1c	D2c	D3c	D4c	D5c	D6c	D7c	D8c	D9c	D10c	D11c	D12c	D13c	D14c	D15c
	9. Lch A volume					10. Lch B Volume						0	0	1	0	

(4)	D0d	D1d	D2d	D3d	D4d	D5d	D6d	D7d	D8d	D9d	D10d	D11d	D12d	D13d	D14d	D15d
	9. Rch A volume					10. Rch B volume						0	0	1	1	



## Setting Code

It's initial setting when VCC turn on.

## 1. Input selector

	D0a	D1a	D2a
INA	0	0	0
INB	0	0	1
INC	0	1	0
IND	0	1	1
ALL OFF	1	1	1

## 2. Karaoke mode control

	D3a	D4a
Stereo	0	0
Lch mono	0	1
Rch mono	1	0
Vocal cut	1	1

## 3. Input gain control

	D5a	D6a
0dB	0	0
+3dB	0	1
+6dB	1	0
+9dB	1	1

## 4. Surround ON/OFF

	D7a
OFF	0
ON	1

## 5. MIC SW

	D8a
OFF	0
ON	1

## 6. Tone control (Bass/Mid/Treble)

ATT	Bass	D0b	D1b	D2b	D3b
	Mid	D4b	D5b	D6b	D7b
	Treble	D8b	D9b	D10b	D11b
+14dB*	1	1	1	1	
+12dB*	1	1	1	0	
+10dB*	1	1	0	1	
+ 8dB	1	1	0	0	
+ 6dB	1	0	1	1	
+ 4dB	1	0	1	0	
+ 2dB	1	0	0	1	
0dB	0	0	0	0	
- 2dB	0	0	0	1	
- 4dB	0	0	1	0	
- 6dB	0	0	1	1	
- 8dB	0	1	0	0	

\*: +14dB +10dB can set up only a Bass.

7. Bypass SW  
(tone block)

	D12b
ON	0
OFF	1

## 8. Bass boost

	D13b
OFF	0
ON	1

## 9. A volume

ATT	Lch AVOL	D0c	D1c	D2c	D3c	D4c
	Rch AVOL	D0d	D1d	D2d	D3d	D4d
0dB	0	0	0	0	0	0
-1dB	0	0	0	0	0	1
-2dB	0	0	0	0	1	0
-3dB	0	0	0	0	1	1
-4dB	0	0	0	1	0	0
-5dB	0	0	0	1	0	1
-6dB	0	0	0	1	1	0
-7dB	0	0	0	1	1	1
-8dB	0	0	1	0	0	0
-9dB	0	0	1	0	0	1
-10dB	0	0	1	0	1	0
-11dB	0	0	1	0	1	1
-12dB	0	0	1	1	0	0
-13dB	0	0	1	1	0	1
-14dB	0	0	1	1	1	0
-15dB	0	0	1	1	1	1
-16dB	1	0	0	0	0	0
-17dB	1	0	0	0	0	1
-18dB	1	0	0	0	1	0
-19dB	1	0	0	0	1	1
-20dB	1	0	0	1	0	0
-21dB	1	0	0	1	0	1
-22dB	1	0	0	1	1	0
-23dB	1	0	0	1	1	1
-24dB	1	1	0	0	0	0

Note : Please don't input except specification data.

## 10. B volume

ATT	Lch BVOL	D5c	D6c	D7c	D8c	D9c	D10c	D11c
	Rch BVOL	D5d	D6d	D7d	D8d	D9d	D10d	D11d
0dB	0	0	0	0	0	0	0	0
-1dB	0	0	0	0	0	0	0	1
-2dB	0	0	0	0	0	0	1	0
-3dB	0	0	0	0	0	0	1	1
-4dB	0	0	0	0	0	1	0	0
-5dB	0	0	0	0	0	1	0	1
-6dB	0	0	0	0	0	1	1	0
-7dB	0	0	0	0	0	1	1	1
-8dB	0	0	0	0	1	0	0	0
-9dB	0	0	0	0	1	0	0	1
-10dB	0	0	0	0	1	0	1	0
-11dB	0	0	0	0	1	0	1	1
-12dB	0	0	0	0	1	1	0	0
-13dB	0	0	0	0	1	1	0	1
-14dB	0	0	0	0	1	1	1	0
-15dB	0	0	0	0	1	1	1	1
-16dB	0	0	0	1	0	0	0	0
-17dB	0	0	0	1	0	0	0	1
-18dB	0	0	0	1	0	0	1	0
-19dB	0	0	0	1	0	0	1	1
-20dB	0	0	0	1	0	1	0	0
-21dB	0	0	0	1	0	1	0	1
-22dB	0	0	0	1	0	1	1	0
-23dB	0	0	0	1	0	1	1	1
-24dB	0	0	0	1	1	0	0	0
-25dB	0	0	0	1	1	0	0	1
-26dB	0	0	0	1	1	0	1	0
-27dB	0	0	0	1	1	0	1	1
-28dB	0	0	0	1	1	1	0	0
-29dB	0	0	0	1	1	1	0	1
-30dB	0	0	0	1	1	1	1	0
-31dB	0	0	0	1	1	1	1	1
-32dB	0	0	1	0	0	0	0	0
-33dB	0	0	1	0	0	0	0	1
-34dB	0	0	1	0	0	0	1	0
-35dB	0	0	1	0	0	0	1	1
-36dB	0	0	1	0	0	1	0	0
-37dB	0	0	1	0	0	1	0	1
-38dB	0	0	1	0	0	1	1	0
-39dB	0	0	1	0	0	1	1	1
-40dB	0	0	1	0	1	0	0	0
-41dB	0	0	1	0	1	0	0	1
-42dB	0	0	1	0	1	0	1	0
-43dB	0	0	1	0	1	0	1	1
-44dB	0	0	1	0	1	1	0	0

ATT	LchVOL	D5c	D6c	D7c	D8c	D9c	D10c	D11c
	RchVOL	D5d	D6d	D7d	D8d	D9d	D10d	D11d
-45dB	0	1	0	1	1	0	1	
-46dB	0	1	0	1	1	1	0	
-47dB	0	1	0	1	1	1	1	
-48dB	0	1	1	0	0	0	0	
-49dB	0	1	1	0	0	0	1	
-50dB	0	1	1	0	0	1	0	
-51dB	0	1	1	0	0	1	1	
-52dB	0	1	1	0	1	0	0	
-53dB	0	1	1	0	1	0	1	
-54dB	0	1	1	0	1	1	0	
-55dB	0	1	1	0	1	1	1	
-56dB	0	1	1	1	0	0	0	
-57dB	0	1	1	1	0	0	1	
-58dB	0	1	1	1	0	1	0	
-59dB	0	1	1	1	0	1	1	
-60dB	0	1	1	1	1	0	0	
-61dB	0	1	1	1	1	0	1	
-62dB	0	1	1	1	1	1	0	
-63dB	0	1	1	1	1	1	1	
-64dB	1	0	0	0	0	0	0	
-65dB	1	0	0	0	0	0	1	
-66dB	1	0	0	0	0	1	0	
-∞ dB	1	1	0	0	0	0	0	

Note : Please don't input except specification data.

## Electrical Characteristics

Unless otherwise noted, Ta=25°C, VCC=9V, f=1kHz,

Input gain control=0dB, Karaoke mode control=Stereo, MIC SW=OFF, Surround=OFF, Bypass SW (tone block)=ON,

Tone=Flat, Bass boost=OFF, A/B volume=0dB

Parameter	Symbol	Condition	Limits			Units	
			MIN	TYP	MAX		
Circuit current	IACC	No signal, Pin20 current	—	20	40	mA	
Input resistance	Rin	3,4,5,6Pin/37,38,39,40Pin/36Pin	25k	50k	75k	Ω	
Maximum input voltage	VIM	(3,40)Pin input,(19,24)Pin output RL=10k, THD=1%	1.6	2.0	—	Vrms	
Maximum output voltage	VOM	(3,40)Pin input,(19,24)Pin output RL=10k, THD=5%,Bass boost ON, f=50Hz	1.8	2.2	—	Vrms	
Pass gain	Gv	(3-19)Pin-(40-24)Pin Vi=1Vrms,FLAT	-2.0	0.0	2.0	dB	
Maximum attenuation	ATT	Vo=1Vrms,(19,24)Pin output JIS-A, VOL=-∞	—	-90	-85	dB	
Output noise voltage	VnoA	No signal, JIS-A, Rg=0 , 19,24Pin output	A/B volume=-∞dB Surround OFF, Tone Bypass ON	—	4	8	μVrms
	VnoB		A/B volume=0dB Surround OFF, Tone Bypass ON	—	7	14	μVrms
	VnoC		A/B volume=0dB Surround OFF, Tone Bypass OFF	—	10	20	μVrms
Total harmonic distortion	THDA	(3,40)Pin input,(19,24)Pin output BW:400 30kHz,Vo=0.5Vrms,RL=10kΩ	—	0.02	0.1	%	
Cross talk of mutual channels	CT	(3-24)Pin-(40-19)Pin Vi=0.5Vrms,JIS-A,RL=10k ,Rg=0Ω	—	-70	-55	dB	
Bass voltage gain	GBbass	(9,34)Pin input	Bass setting=+14dB	12	14	16	dB
		(15,28)Pin output	Bass setting=-8dB	-10	-8	-6	dB
	GCbass	Vi=0.2Vrms, f=100Hz					
	GBmid	(9,34)Pin input	Mid setting=+8dB	6	8	10	dB
		(15,28)Pin output	Mid setting=-8dB	-10	-8	-6	dB
GCmid	Vi=0.2Vrms, f=1kHz						
GBtre	(9,34)Pin input	Treble setting=+8dB	6	8	10	dB	
	(15,28)Pin output	Treble setting= -8dB	-10	-8	-6	dB	
GCtre	Vi=0.2Vrms, f=10kHz						
Balance of mutual channels	BALT	Boost condition +8,-8dB (9,34)Pin input,(15,28)Pin output	-2	0	2	dB	

Internal Block Diagram

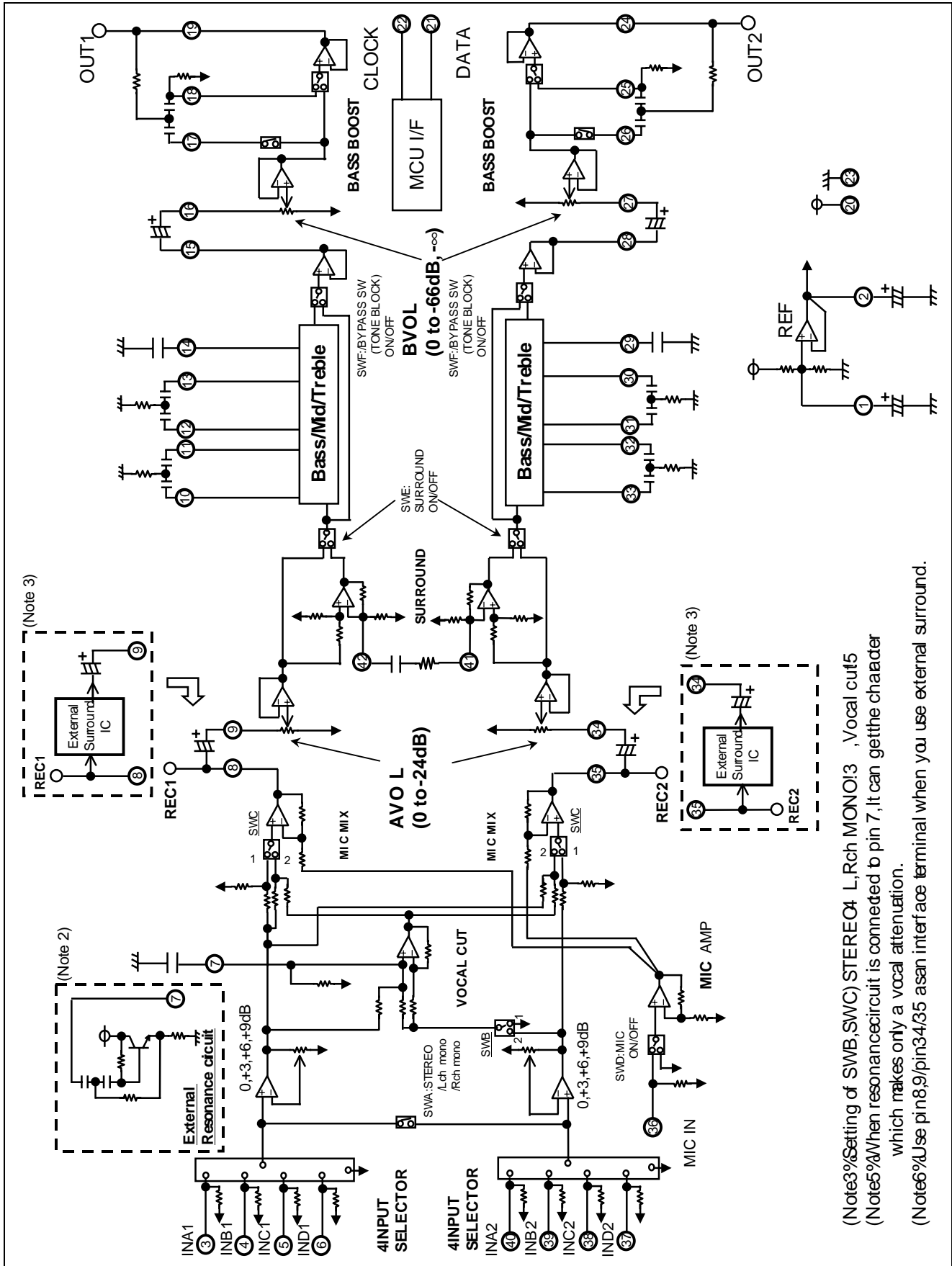

- (Note3)Setting of SWB,SWC) STEREO4 L,Rch MONO)3 ,Vocal cut5
- (Note5)When resonancecircuit is connected to pin 7, it can get the chaader which makes only a vocal attenuation.
- (Note6)Use pin8,9/pin34/35 asan interface terminal when you use external surround.

Tone Control

(1) Bass/Mid

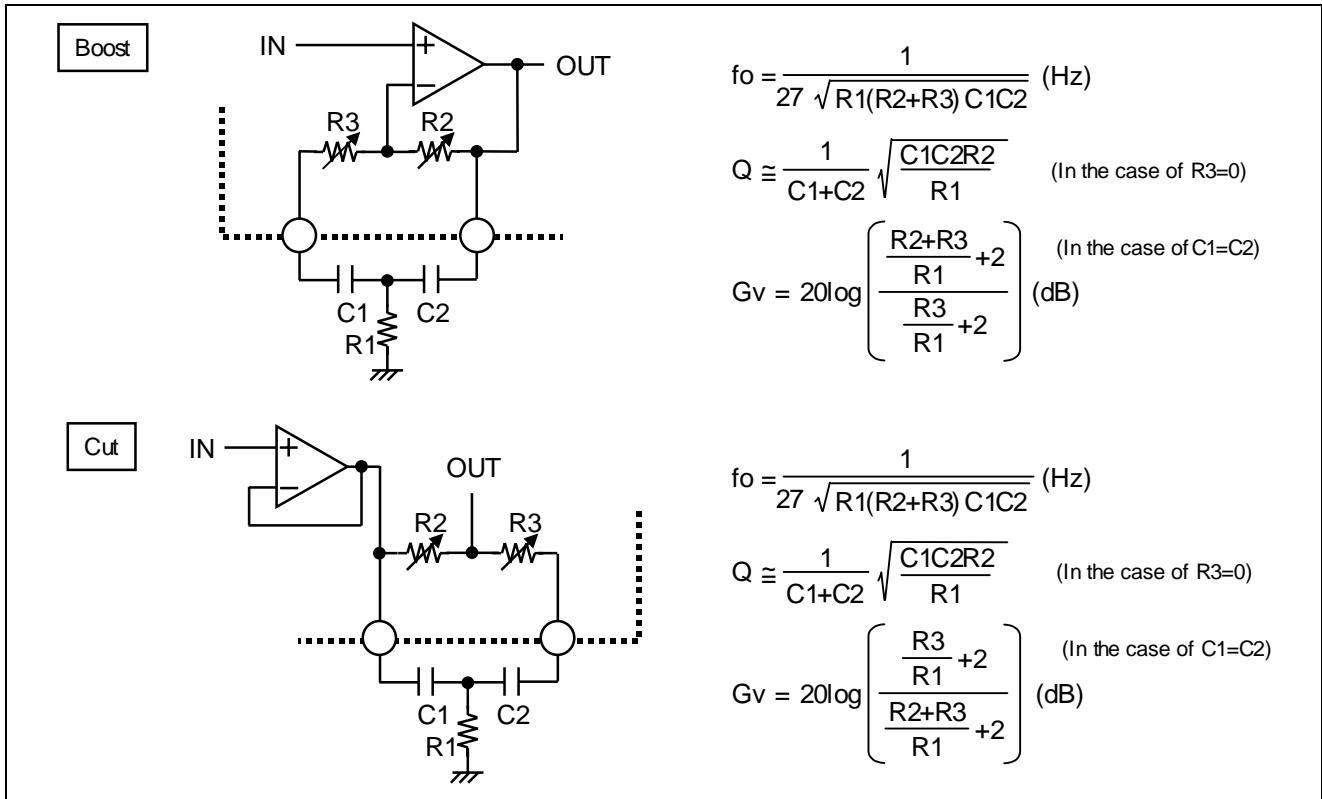

(2) Treble

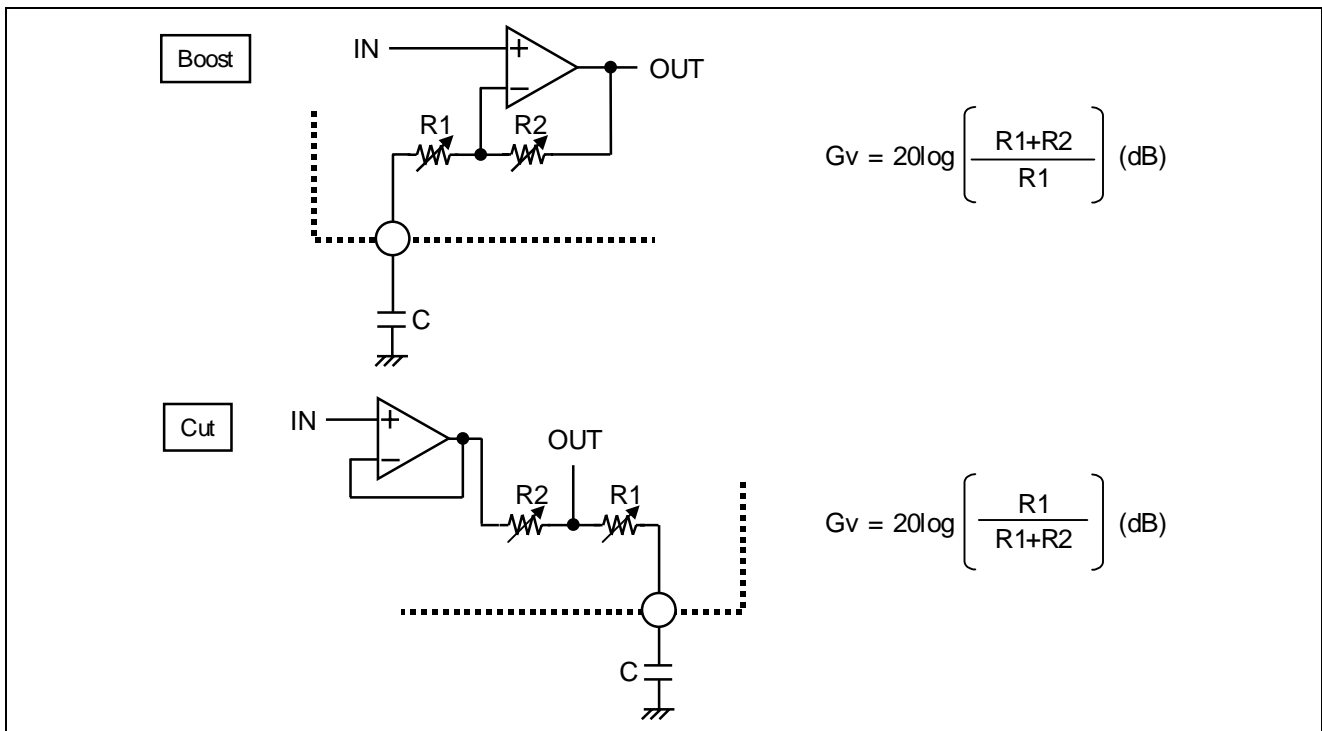

**Frequency response of tone control**

\* This frequency response is a simulation result.

(1) Bass ( $R1=2.2k\Omega$ ,  $C1=C2=0.22\mu F$ )

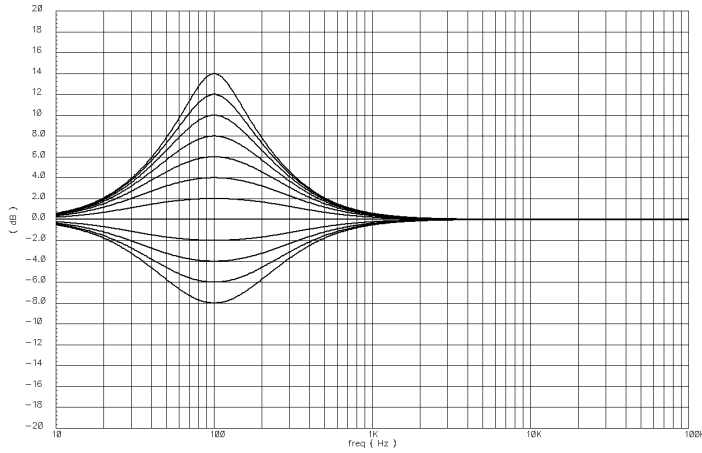

• Internal resistance value(Reference value)

	R2	R3
+14dB	22.6k	1.2k
+12dB	21.1k	2.7k
+10dB	19.3k	4.5k
± 8dB	17.0k	6.8k
± 6dB	14.1k	9.7k
± 4dB	10.4k	13.4k
± 2dB	5.8k	18.0k

(Units:  $\Omega$ )

(2) Mid ( $R1=2.2k\Omega$ ,  $C1=C2=0.022\mu F$ )

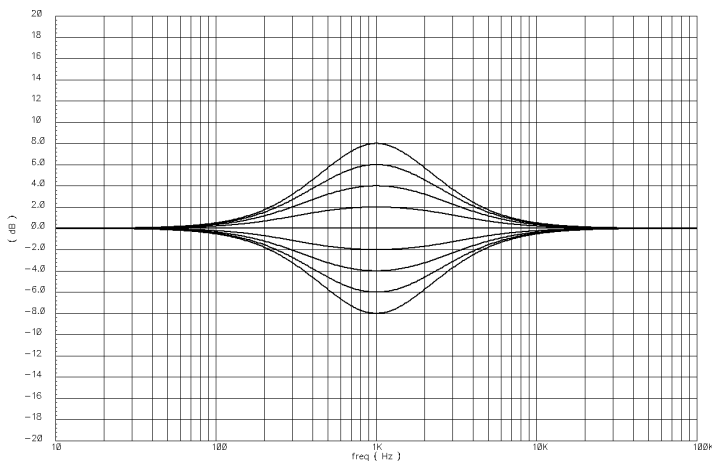

• Internal resistance value(Reference value)

	R2	R3
± 8dB	17.0k	6.8k
± 6dB	14.1k	9.7k
± 4dB	10.4k	13.4k
± 2dB	5.8k	18.0k

(Units:  $\Omega$ )

(3) Treble (C=4700pF)

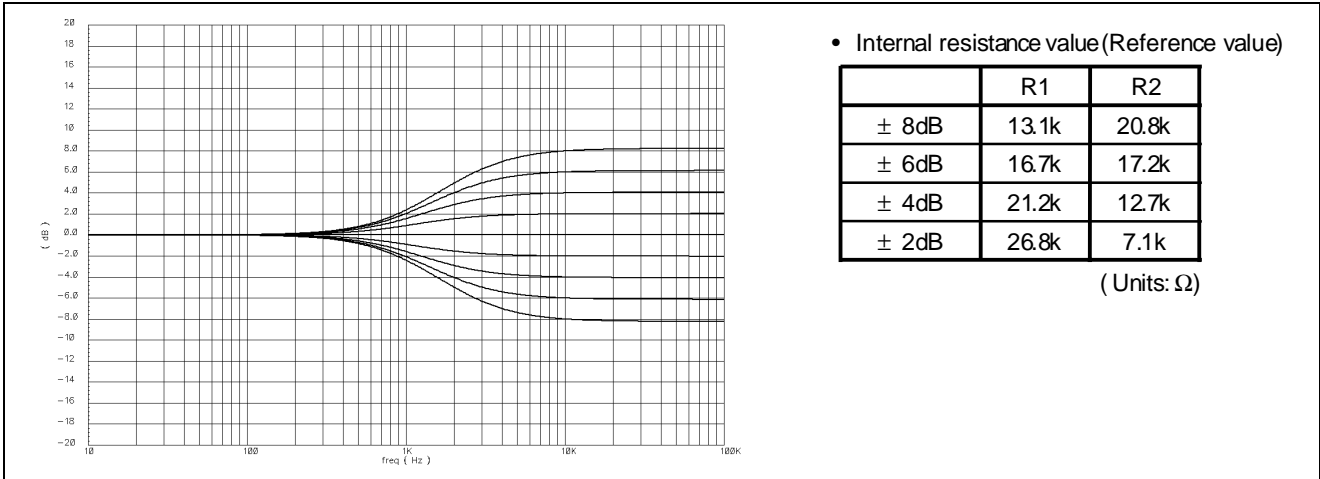

**Bass Boost**

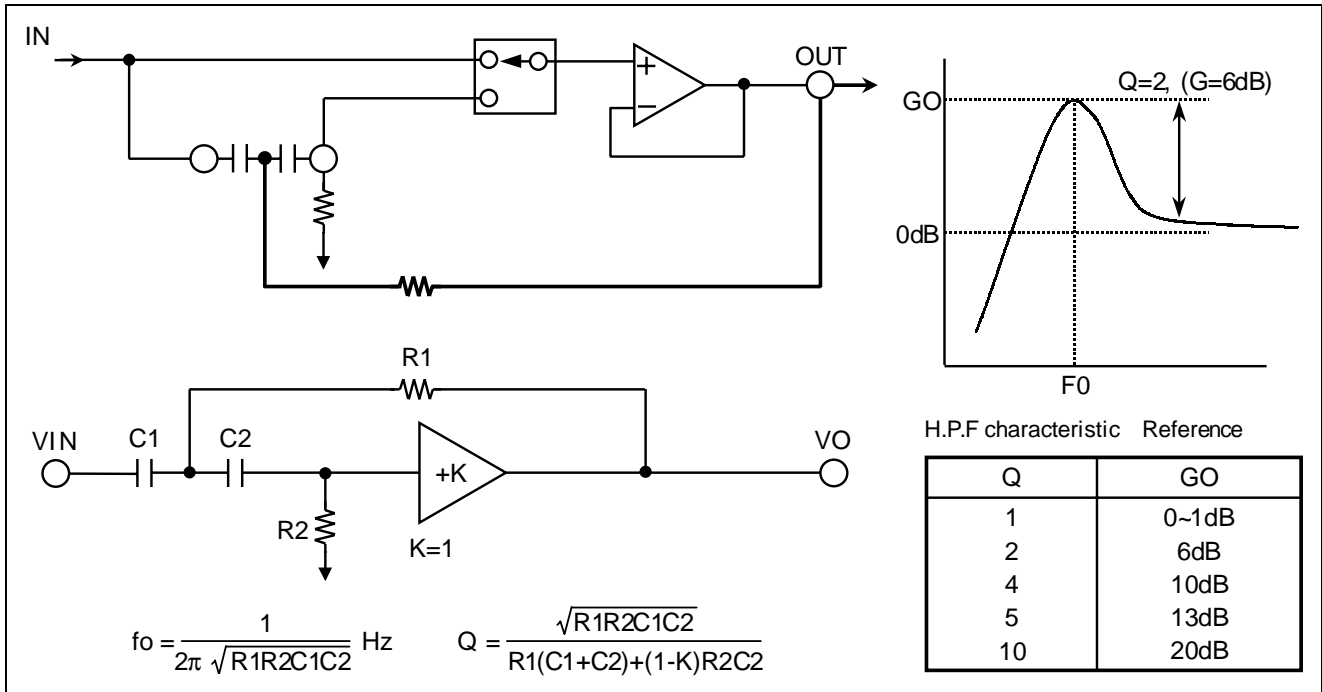

**Frequency response of Bass boost**

R1=1.8kΩ, R2=27kΩ, C1=C2=0.47μF(f0≒50Hz, Q≒2)

\* This frequency response is a simulation result.

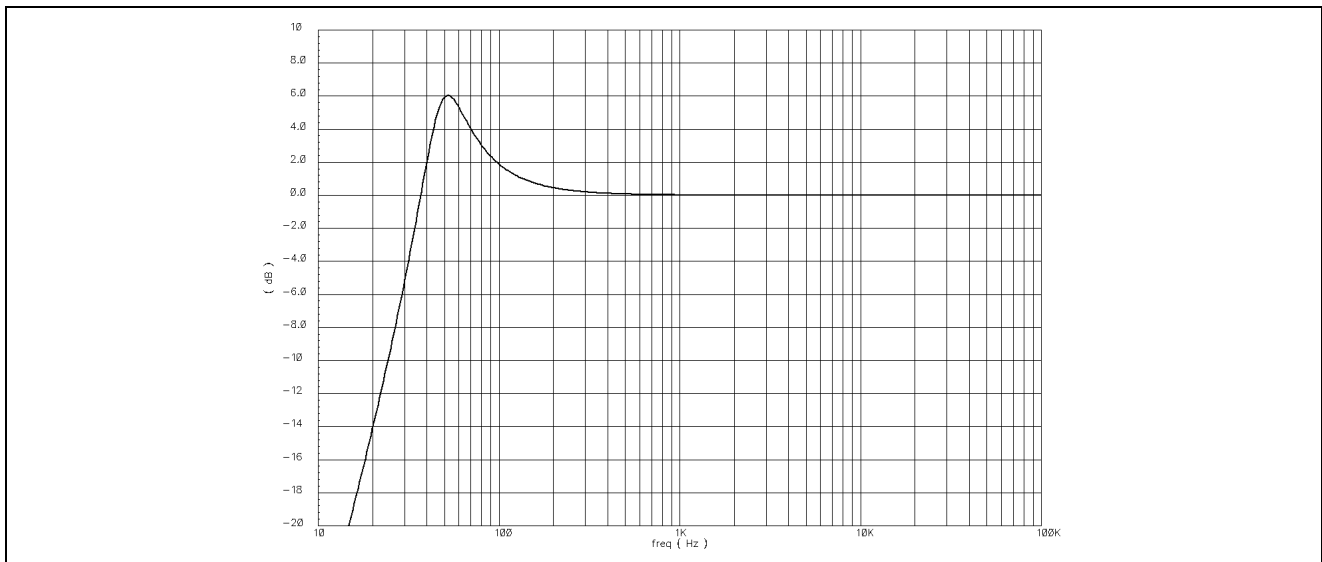



Surround

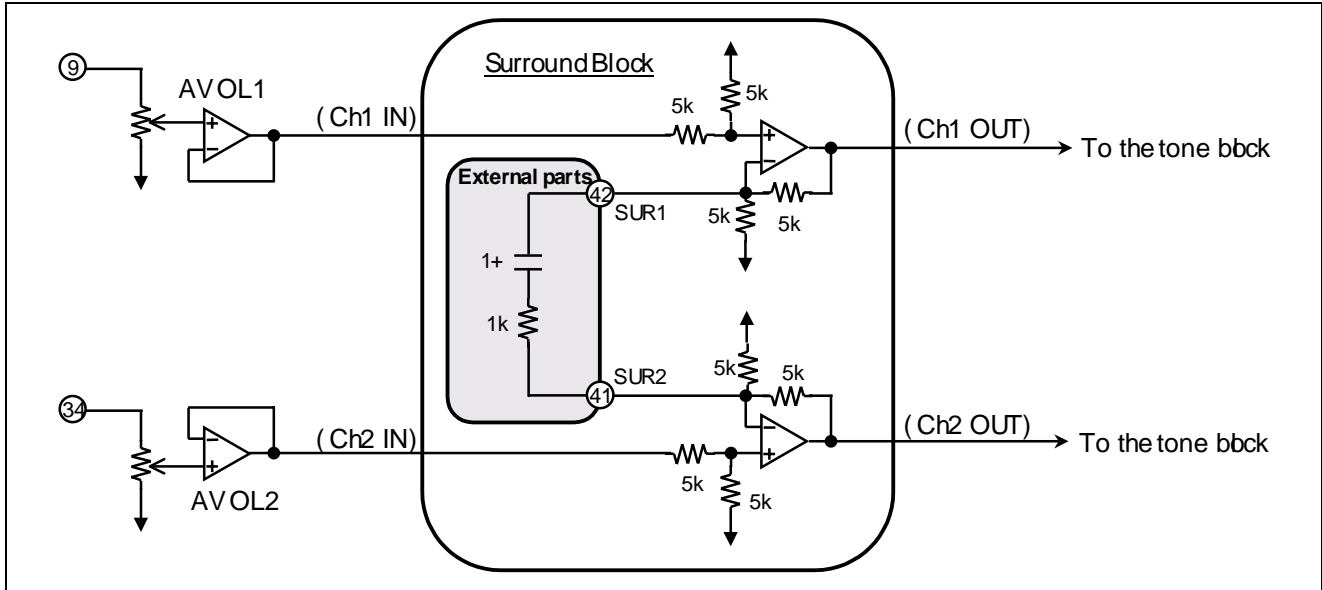

Frequency response of Surround (Ch1:input, Ch2:GND)

\* This frequency response is a simulation result.

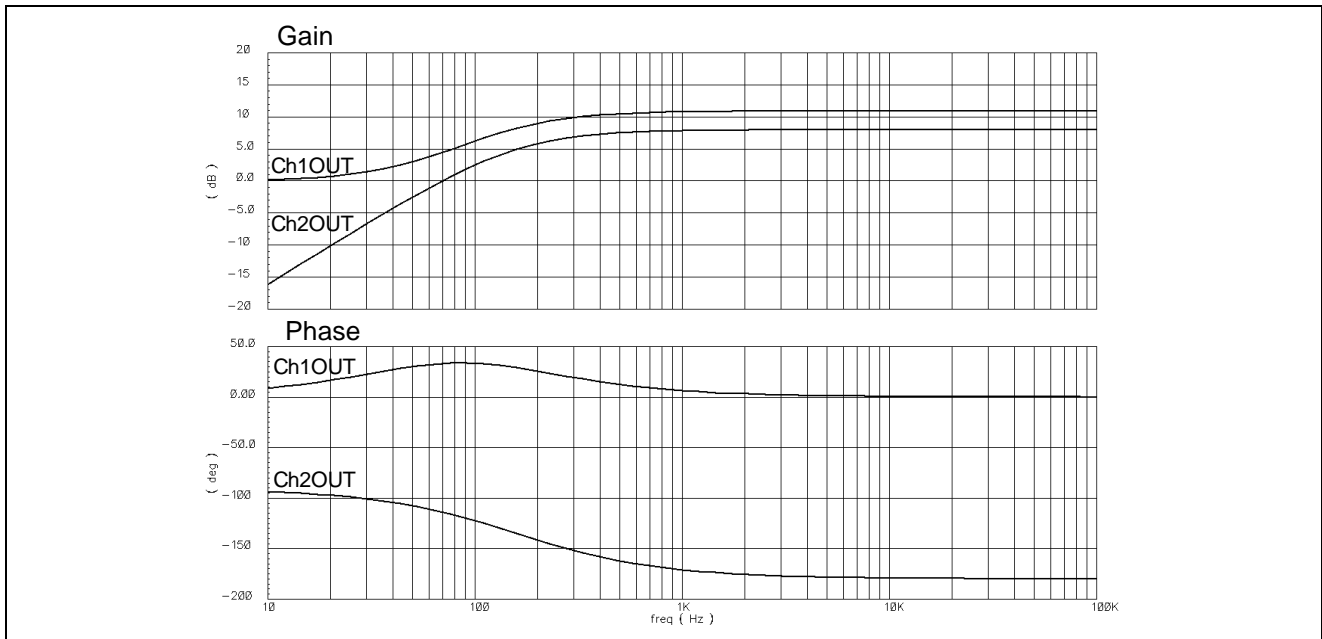

### Vocal Cut

It is the function which attenuate a vocal from the music source.

The vocal is usually located in the center. And it is same amplitude and phase in L and R channel.

So, a vocal inside music is attenuated by doing L-R. But, a low frequency signal be attenuated in this case.

Therefore, a low frequency signal be made to pass with LPF, and it makes up for the shortage of the low frequency signal.

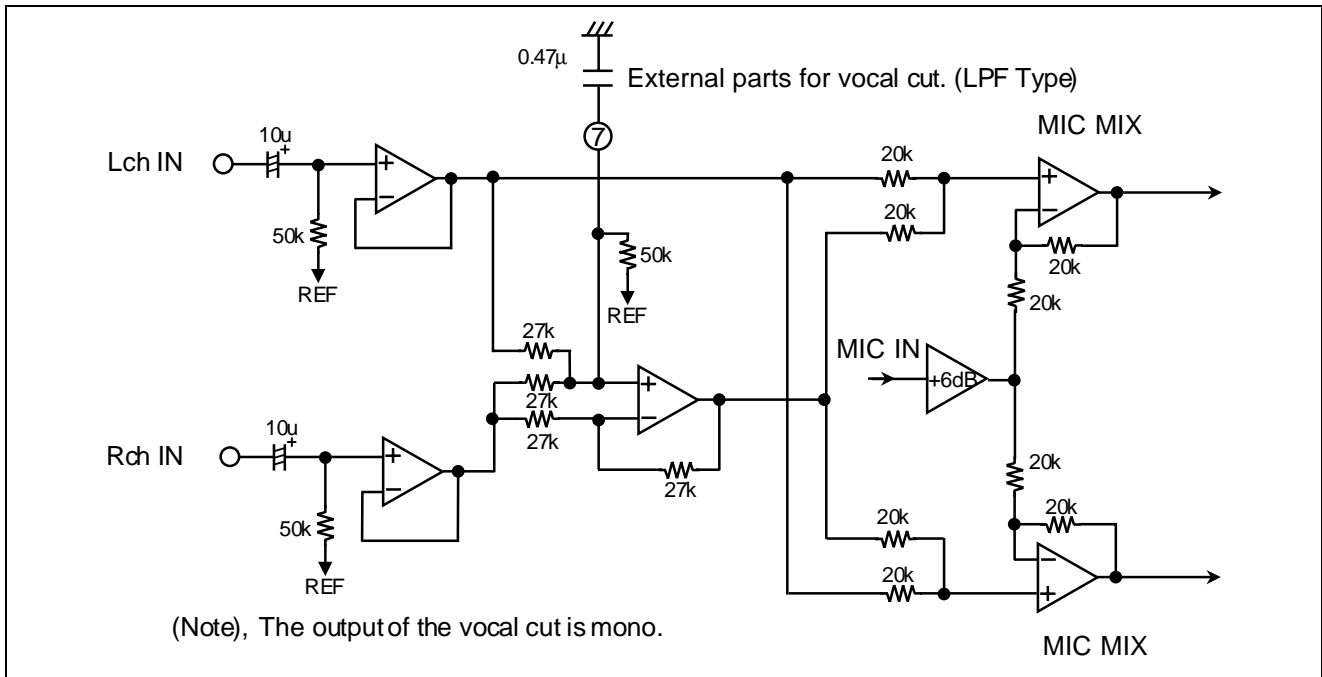

When resonance circuit is connected to pin 7, It can get the character which makes only a vocal attenuation.

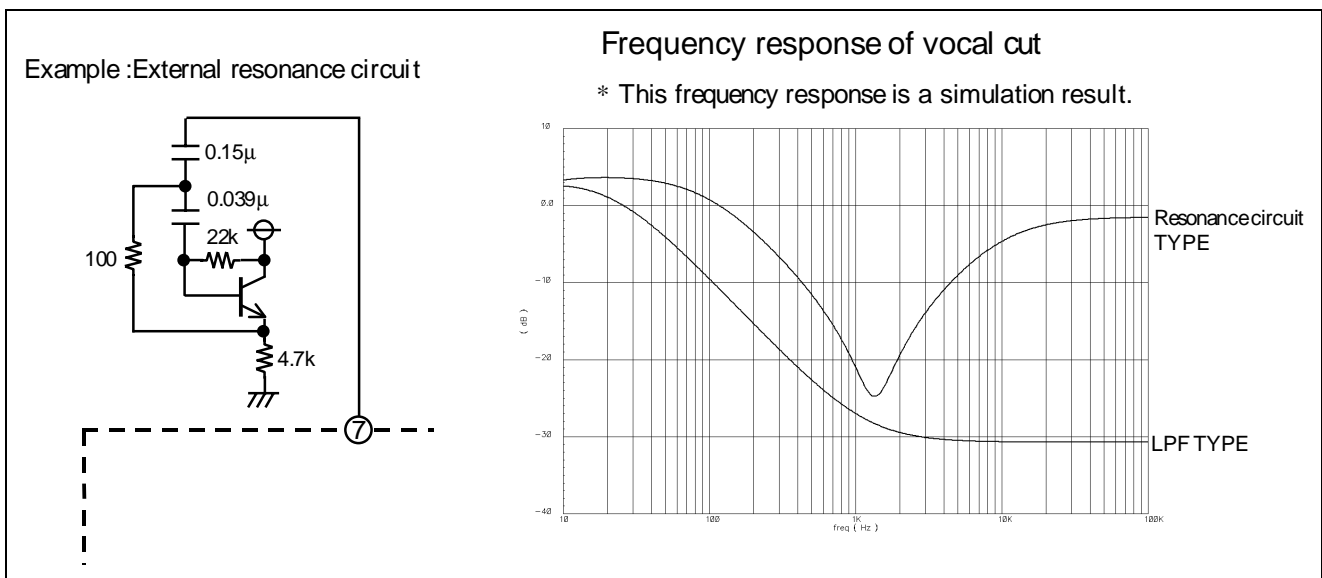

Application Example

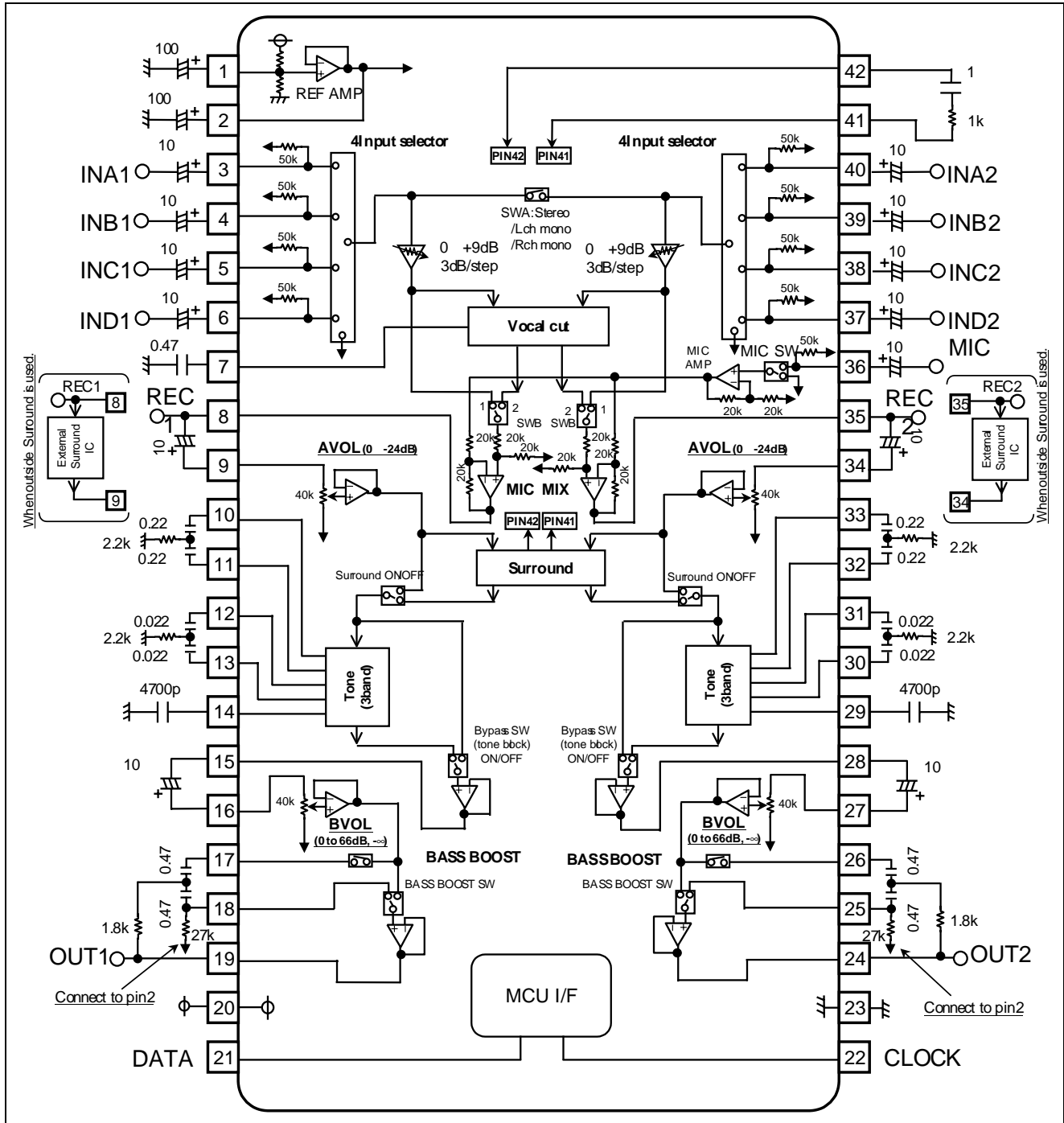

Package Dimensions

**42P2R-E** (MMP) Plastic 42pin 450mil SSOP

EIAJ Package Code SSOP42-P-450-0.80	JEDEC Code —	Weight(g) —	Lead Material Cu Alloy+42 Alloy
--	-----------------	----------------	------------------------------------

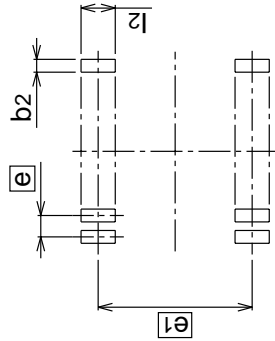
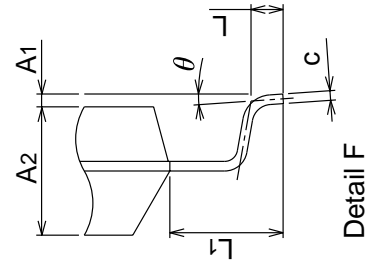
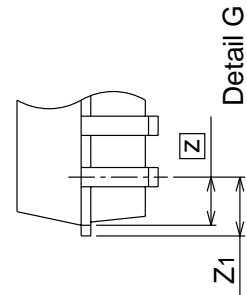
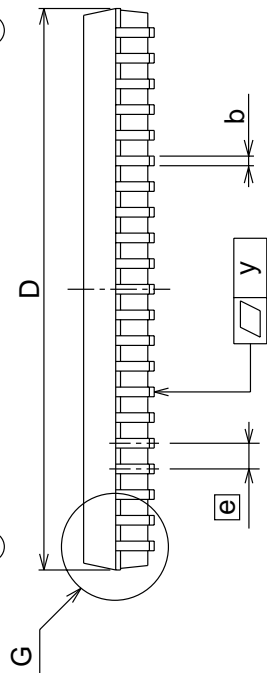
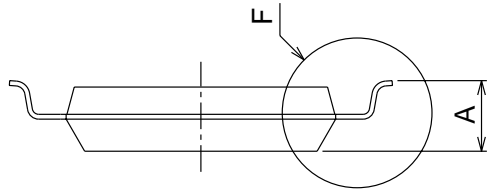
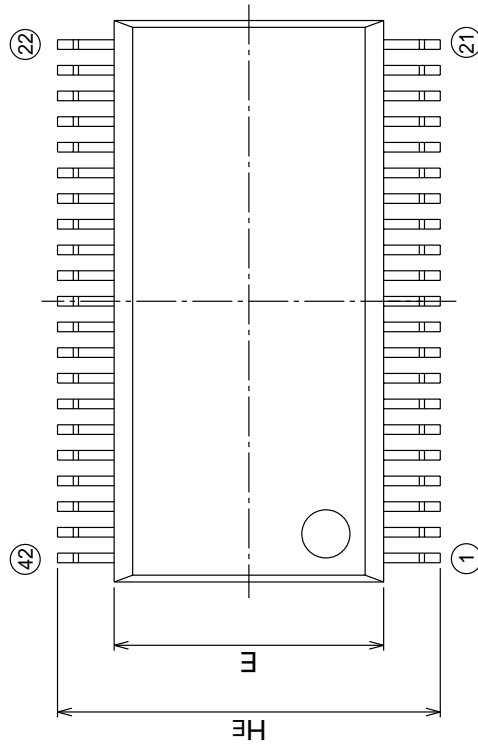

Recommended Mount Pad

Symbol	Dimension in Millimeters		
	Min	Norm	Max
A	—	—	2.4
A1	0.05	—	—
A2	—	2.0	—
b	0.25	0.3	0.4
c	0.13	0.15	0.2
D	17.3	17.5	17.7
E	8.2	8.4	8.6
e	—	0.8	—
HE	11.63	11.93	12.23
L	0.3	0.5	0.7
L1	—	1.765	—
Z	—	0.75	—
Z1	—	—	0.9
y	—	—	0.15
theta	0°	—	10°
b2	—	0.5	—
e1	—	11.43	—
l2	1.27	—	—

## Renesas Technology Corp. Sales Strategic Planning Div. Nippon Bldg., 2-6-2, Ohte-machi, Chiyoda-ku, Tokyo 100-0004, Japan

---

Keep safety first in your circuit designs!

1. Renesas Technology Corp. puts the maximum effort into making semiconductor products better and more reliable, but there is always the possibility that trouble may occur with them. Trouble with semiconductors may lead to personal injury, fire or property damage.  
Remember to give due consideration to safety when making your circuit designs, with appropriate measures such as (i) placement of substitutive, auxiliary circuits, (ii) use of nonflammable material or (iii) prevention against any malfunction or mishap.

Notes regarding these materials

1. These materials are intended as a reference to assist our customers in the selection of the Renesas Technology Corp. product best suited to the customer's application; they do not convey any license under any intellectual property rights, or any other rights, belonging to Renesas Technology Corp. or a third party.
  2. Renesas Technology Corp. assumes no responsibility for any damage, or infringement of any third-party's rights, originating in the use of any product data, diagrams, charts, programs, algorithms, or circuit application examples contained in these materials.
  3. All information contained in these materials, including product data, diagrams, charts, programs and algorithms represents information on products at the time of publication of these materials, and are subject to change by Renesas Technology Corp. without notice due to product improvements or other reasons. It is therefore recommended that customers contact Renesas Technology Corp. or an authorized Renesas Technology Corp. product distributor for the latest product information before purchasing a product listed herein.  
The information described here may contain technical inaccuracies or typographical errors.  
Renesas Technology Corp. assumes no responsibility for any damage, liability, or other loss rising from these inaccuracies or errors.  
Please also pay attention to information published by Renesas Technology Corp. by various means, including the Renesas Technology Corp. Semiconductor home page (<http://www.renesas.com>).
  4. When using any or all of the information contained in these materials, including product data, diagrams, charts, programs, and algorithms, please be sure to evaluate all information as a total system before making a final decision on the applicability of the information and products. Renesas Technology Corp. assumes no responsibility for any damage, liability or other loss resulting from the information contained herein.
  5. Renesas Technology Corp. semiconductors are not designed or manufactured for use in a device or system that is used under circumstances in which human life is potentially at stake. Please contact Renesas Technology Corp. or an authorized Renesas Technology Corp. product distributor when considering the use of a product contained herein for any specific purposes, such as apparatus or systems for transportation, vehicular, medical, aerospace, nuclear, or undersea repeater use.
  6. The prior written approval of Renesas Technology Corp. is necessary to reprint or reproduce in whole or in part these materials.
  7. If these products or technologies are subject to the Japanese export control restrictions, they must be exported under a license from the Japanese government and cannot be imported into a country other than the approved destination.  
Any diversion or reexport contrary to the export control laws and regulations of Japan and/or the country of destination is prohibited.
  8. Please contact Renesas Technology Corp. for further details on these materials or the products contained therein.
- 



### RENESAS SALES OFFICES

<http://www.renesas.com>

**Renesas Technology America, Inc.**  
450 Holger Way, San Jose, CA 95134-1368, U.S.A  
Tel: <1> (408) 382-7500 Fax: <1> (408) 382-7501

**Renesas Technology Europe Limited.**  
Dukes Meadow, Millboard Road, Bourne End, Buckinghamshire, SL8 5FH, United Kingdom  
Tel: <44> (1628) 585 100, Fax: <44> (1628) 585 900

**Renesas Technology Europe GmbH**  
Dornacher Str. 3, D-85622 Feldkirchen, Germany  
Tel: <49> (89) 380 70 0, Fax: <49> (89) 929 30 11

**Renesas Technology Hong Kong Ltd.**  
7/F., North Tower, World Finance Centre, Harbour City, Canton Road, Hong Kong  
Tel: <852> 2265-6688, Fax: <852> 2375-6836

**Renesas Technology Taiwan Co., Ltd.**  
FL 10, #99, Fu-Hsing N. Rd., Taipei, Taiwan  
Tel: <886> (2) 2715-2888, Fax: <886> (2) 2713-2999

**Renesas Technology (Shanghai) Co., Ltd.**  
26/F., Ruijin Building, No.205 Maoming Road (S), Shanghai 200020, China  
Tel: <86> (21) 6472-1001, Fax: <86> (21) 6415-2952

**Renesas Technology Singapore Pte. Ltd.**  
1, Harbour Front Avenue, #06-10, Keppel Bay Tower, Singapore 098632  
Tel: <65> 6213-0200, Fax: <65> 6278-8001