



# MAP3204

## 4-channel LED Driver for High Brightness LEDs

MAP3204 – 4-Channel LED Driver for High Brightness LEDs

### General Description

The MAP3204 is a 4-channel LED driver optimized for LED backlight application targeting mid and large size LCD module. It uses the boost MOSFET externally and 4-channel current sources internally for driving high brightness white LEDs

Input voltage of the MAP3204 is ranged from 7V ~ 36V and max. LED current is 150mA per channel. It can increase the output voltage depending on the drain voltage rating of boost MOSFET.

It features PWM dimming control, internal soft-start and 1.5% current matching between channels and has protections like output over-voltage and LED short/open and UVLO.

The MAP3204 is available in 16 leads E-TSSOP and 20 leads SOIC package with Halogen-free (fully RoHS compliant).

### Features

- 7V to 36V Input Voltage Range
- Drive up to 4 Channels
- 150mA Output Current per Channel
- 1.5% Current Matching
- Programmable Boost Switching Frequency : 100kHz to 500kHz
- PWM Dimming : up to 22kHz
- Current Mode Control
- Boost Over Current Protection
- Output Over Voltage Protection
- LED Short/Open Protection
- UVLO
- 16 leads E-TSSOP and 20 leads SOIC

### Applications

- High Brightness white LED backlighting for mid and large size LCD module
- General LED lighting applications

### Ordering Information

Part Number	Top Marking	Ambient Temperature Range	Package	RoHS Status
MAP3204SIRH	MAP3204	-40°C to +85°C	20 leads SOIC	Halogen Free
MAP3204TERH	MAP3204	-40°C to +85°C	16 leads TSSOP with E-Pad	Halogen Free

### Typical Application

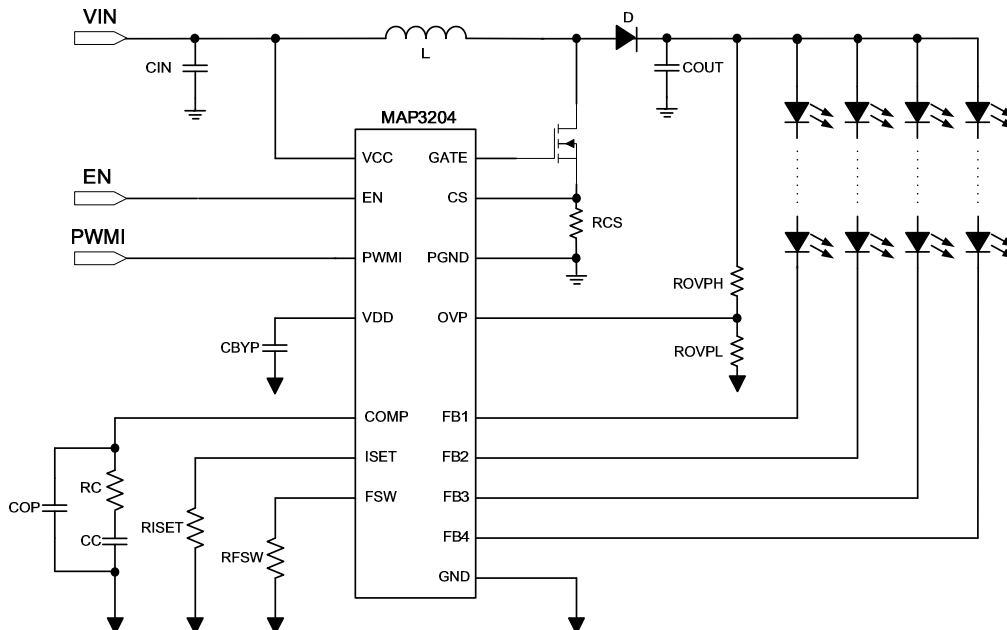

Pin Configuration

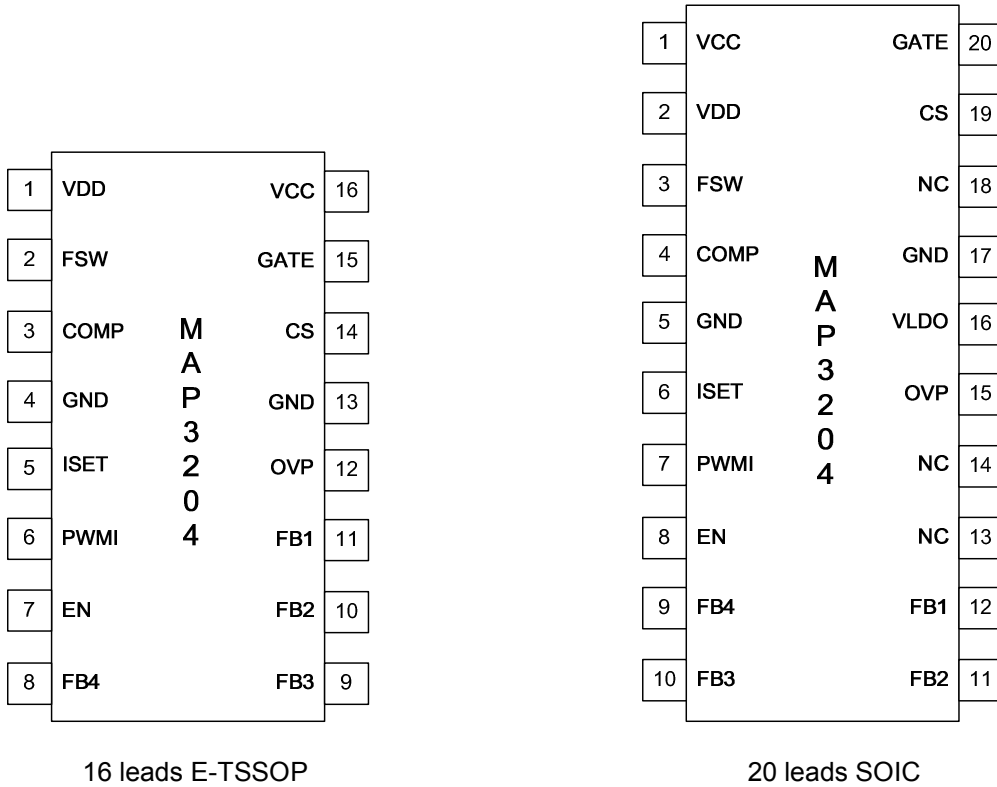

Functional Block Diagram

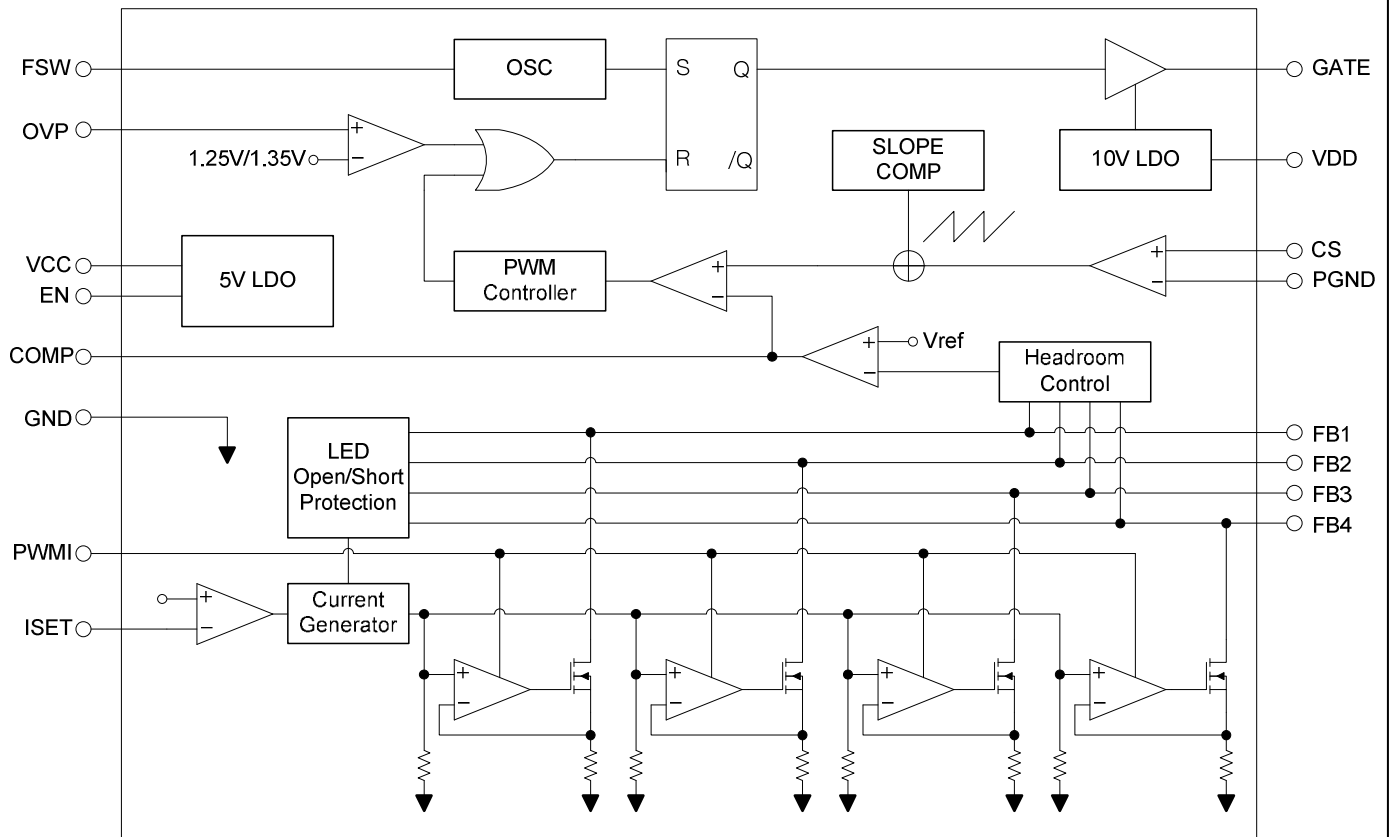

## Pin Description

Name	16leads E-TSSOP	20leads SOIC	Description
VCC	16	1	Power supply input. Need external input capacitor.
GND	4, 13	5, 17	Ground
VDD	1	2	Internal 10V Regulator Output. Connect to 2.2uF capacitor
FSW	2	3	Booster switching frequency adjustment pin (Note 1)
COMP	3	4	Internal error amplifier compensation pin (Note 2)
ISET	5	6	Max. LED current adjustment pin (Note3)
EN	7	8	Enable pin. Active High.
PWMI	6	7	PWM signal input for dimming (Note 4)
FB1	11	12	LED current sink for Ch1
FB2	10	11	LED current sink for Ch2
FB3	9	10	LED current sink for Ch3
FB4	8	9	LED current sink for Ch4
OVP	12	15	Over voltage sense pin (Note 5)
CS	14	19	Boost current sense pin (Note 6)
GATE	15	20	Gate driver output for external power MOSFET
VLDO	-	16	Internal 5V Regulator Output. Connect to 2.2uF capacitor
NC	-	13, 14, 18	Connect to ground for heat-sinking purpose
-	Exposed PAD	-	Connect to ground by multiple vias for heat-sinking purpose (Note 7)

**Note 1:** Connect external resistor to set the oscillator frequency from 100kHz to 500kHz.

**Note 2:** Connect external capacitor and resistor to COMP pin. Refer to a typical application diagram.

**Note 3:** The resistor value on ISET pin will control the full scale level of sink current on FB- pins. Do not leave this pin open.

**Note 4:** This external PWM signal is used for brightness control.

**Note 5:** Connect center node of resistive voltage divider from output to ground. Refer to a typical application diagram.

**Note 6:** Connect external resistor to PGND to sense the external power MOSFET drain current.

**Note 7:** Not connected internally.

**Absolute Maximum Ratings** (Note 1)

Symbol	Parameter	Min	Max	Unit
$V_{CC}$	Supply Voltage	-0.3	36	V
$V_{GATE}$	Gate Driver Output	-0.3	14	V
$V_{VDD}$	VDD Pin	-0.3	14	V
$V_{EN}, V_{CS}, V_{PWMI}, V_{COMP}, V_{OVP}, V_{FSW}, V_{ISET}$	Input Voltage Signal Level on EN, CS, PWMI, COMP, OVP, FSW, ISET	-0.3	7	V
$V_{FB1-4}$	LED Current Sink Pin	-0.3	65	V
$I_{FB1-4}$	LED Current Sink Pin		200	mA
$T_{PAD}$	Soldering Lead/ Pad Temperature 10sec		300	°C
$T_J$	Junction Temperature	-40	+150	°C
$T_S$	Storage Temperature	-65	+150	°C
ESD	HBM on All Pins (Note 2)	-2000	+2000	V
	MM on All Pins (Note 3)	-200	+200	

**Note 1:** Stresses beyond the above listed maximum ratings may damage the device permanently. Operating above the recommended conditions for extended time may stress the device and affect device reliability. Also the device may not operate normally above the recommended operating conditions. These are stress ratings only.

**Note 2:** ESD tested per JESD22A-114.

**Note 3:** ESD tested per JESD22A-115.

**Recommended Operating Conditions** (Note 1)

Symbol	Parameter	Min	Max	Unit
$V_{CC}$	Supply Input Voltage	7.0	36	V
$I_{FB1-4}$	LED Current Sink Pin	50	150	mA
$V_{FB1-4}$	LED Current Sink Pin		65	V
$T_A$	Ambient Temperature (Note 2)	-40	+85	°C

**Note 1:** Normal operation of the device is not guaranteed if operating the device over outside range of recommended conditions.

**Note 2:** The ambient temperature may have to be derated if used in high power dissipation and poor thermal resistance conditions.

## Electrical Characteristics

Unless noted,  $V_{IN} = 12V$ ,  $C_{IN} = 1.0\mu F$ , and typical values are tested at  $T_A = 25^\circ C$ . **Boldface** values indicate  $-40^\circ C$  to  $+85^\circ C$  of  $T_A$ .

Parameter	Test Condition	Min	Typ	Max	Unit
<b>General Input Output Specifications</b>					
$V_{CC}$	Input Voltage Range	<b>7.0</b>		<b>36</b>	V
$I_Q$	Quiescent Current	Driving FBs at minimum setting with no load		TBD	TBD
$I_{GND}$	Ground Pin Current in Shutdown	$V_{IN} = 12V$ , $V_{EN} = 0V$ No Load Current on FB-	$T_A = 25^\circ C$ $-40^\circ C < T_A < 85^\circ C$	TBD	$\mu A$
$V_{EN}$	Logic Input Level on EN pin	$V_{EN\_L}$ : Logic Low $V_{EN\_H}$ : Logic High		2.0	0.8
<b>Oscillator</b>					
$f_{SW}$	Internal Oscillator Frequency	$R_{FSW}=250k\Omega$	<b>180</b>	<b>200</b>	<b>220</b>
		$R_{FSW}=100k\Omega$	<b>450</b>	<b>500</b>	<b>550</b>
$D_{max}$	Maximum Duty Cycle		85	90	%
<b>Reference</b>					
$V_{VDD}$	10V LDO Voltage	$V_{IN} > 12V$ , No load current		<b>10</b>	V
<b>Gate Driver</b>					
$V_{GATE}$	Gate Drive Voltage	$V_{IN} > 14V$	8	10	12
<b>Protection</b>					
$T_{SD}$	Thermal Shutdown Temperature	Shutdown Temperature		150	$^\circ C$
		Hysteresis, $\Delta T_{SD}$		25	
$V_{OVP}$	Over-Voltage Threshold Level on OVP pin	Rising Over-Voltage Limit on OVP pin		1.21	1.25
		Hysteresis, $\Delta V_{OVP}$		0.1	1.29
$V_{SCP}$	LED Short Protection Threshold	FB1 ~ FB4		5.5	V
$V_{CS}$	Boost Over Current Protection Threshold		0.5		V
$V_{OPEN}$	LED Open Protection Threshold	$V_{FB1-4}=0.8V$		0.2	V
<b>LED Current Sink Regulator</b>					
$V_{FB1-4}$	Minimum FB1~FB4 voltage for the operation to sink 150mA	$I_{SET}=150mA$		0.8	V
$I_{FB}$	Current Accuracy			$\pm 3$	%
$K_m$	Current Matching $(I_{max}-I_{min}) / (I_{max}+I_{min}) * 100$			<b>1.5</b>	%
$I_{FB\_max}$	Current Sink max Current			<b>150</b>	mA
$R_{FBPULLDOWN}$	Pull-Down Resistance on FB1~4		100		$k\Omega$
<b>PWM Interface</b>					
$f_{PWM}$	PWM dimming frequency			22	kHz
$V_{PWMI}$	Logic Input Level on PWMI pin	$V_{PWMI\_L}$ : Logic Low $V_{PWMI\_H}$ : Logic High		2.2	0.8
$I_{PWM}$	Leakage Current on PWMI pin	$V_{PWM}=1V$		2	$\mu A$
$t_{PWMON\_MIN}$	Minimum On-Duty	$f_{PWM}=1kHz$		10	us
<b>Boost MOSFET Driver</b>					
$I_{SINK}$	Gate Source Current		TBD		A
$I_{SOURCE}$	Gate Sink Current		TBD		A
$T_{RISE}$	Gate Output Rising Time		TBD		ns
$T_{FALL}$	Gate Output Falling Time		TBD		ns

## Application Information

### CURRENT MODE BOOST SWITCHING CONTROLLER OPERATION

The MAP3204 employs current mode control boost architecture that has a fast current sense loop and a slow voltage feedback loop. Such architecture achieves a fast transient response that is essential for the LED backlight application.

### DYNAMIC HEADROOM CONTROL

The MAP3204 features a proprietary Dynamic Headroom Control circuit that detects the lowest voltage from any of the FB1-FB4 pins. This lowest channel voltage is used as the feedback signal for the boost controller. Since all LED stacks are connected in parallel to the same output voltage, the other FB pins will have a higher voltage, but the regulated current source circuit on each channel will ensure that each channel has the same current.

### INTERNAL 5V/10V REGULATOR

The MAP3204 has built-in 5V LDO regulator to supply internal analog and logic blocks. The LDO is powered up when the EN pin is Logic High.

A 10V LDO is used to drive external MOSFET connected to the GATE pin. A 2.2uF bypass capacitor is required for stable operation of the LDO.

### OVER VOLTAGE PROTECTION

To protect the boost converter when the load is open, or the output voltage becomes excessive for any reason, the MAP3204 features a dedicated overvoltage feedback input. The OVP pin is connected to the center tap of a resistive voltage-divider from the high voltage output (see the typical application). When the OVP pin voltage exceeds 1.25V, a comparator turns off the external power MOSFET. This switch is re-enabled after the OVP pin voltage drops 100mV(typical) hysteresis below the protection threshold. This over voltage protection feature ensures the boost converter fail-safe operation when the LED channels are disconnected from the output.

The OVP level can be calculated with the following equation.

$$V_{OUT\_OVP} = 1.25 \times \frac{R_{OVPH} + R_{OVPL}}{R_{OVPL}}$$

### DIMMING SCHEME

When PWM signal stays at low level (<0.8V) for a long time, the MAP3204 turns off the boost circuitry, but internal circuit is enabled so the MAP3204 increases the output voltage promptly.

The minimum dimming on duty is 1% at 1kHz = 10us.

### PARALLEL OPERATION

Even the MAP3204 has 4Ch and 150mA LED current capability per channel, 2Ch and 300mA application can be supported by tying 2FBs into 1ch, so the LED current capability can be increased to 300mA.

### LED OPEN PROTECTION

In case the voltage on LED current sink pins (FB1~4) are below 0.2V due to LED open, the MAP3204 turns off the corresponding string and the remaining string(s) will continue operation. Once the LED open status is removed, the corresponding string is automatically recovered.

### LED SHORT PROTECTION

If the voltage at any of the FB1-4 pins exceeds a threshold of approximately 5.5V due to LED short during normal operation, the MAP3204 turns off the corresponding string and the remaining string(s) will continue operation. If all the strings are shorted, the MAP3204A will be shutdown and latched. The operation is resumed by a toggling of the EN pin.

OPERATION TIMING CHART

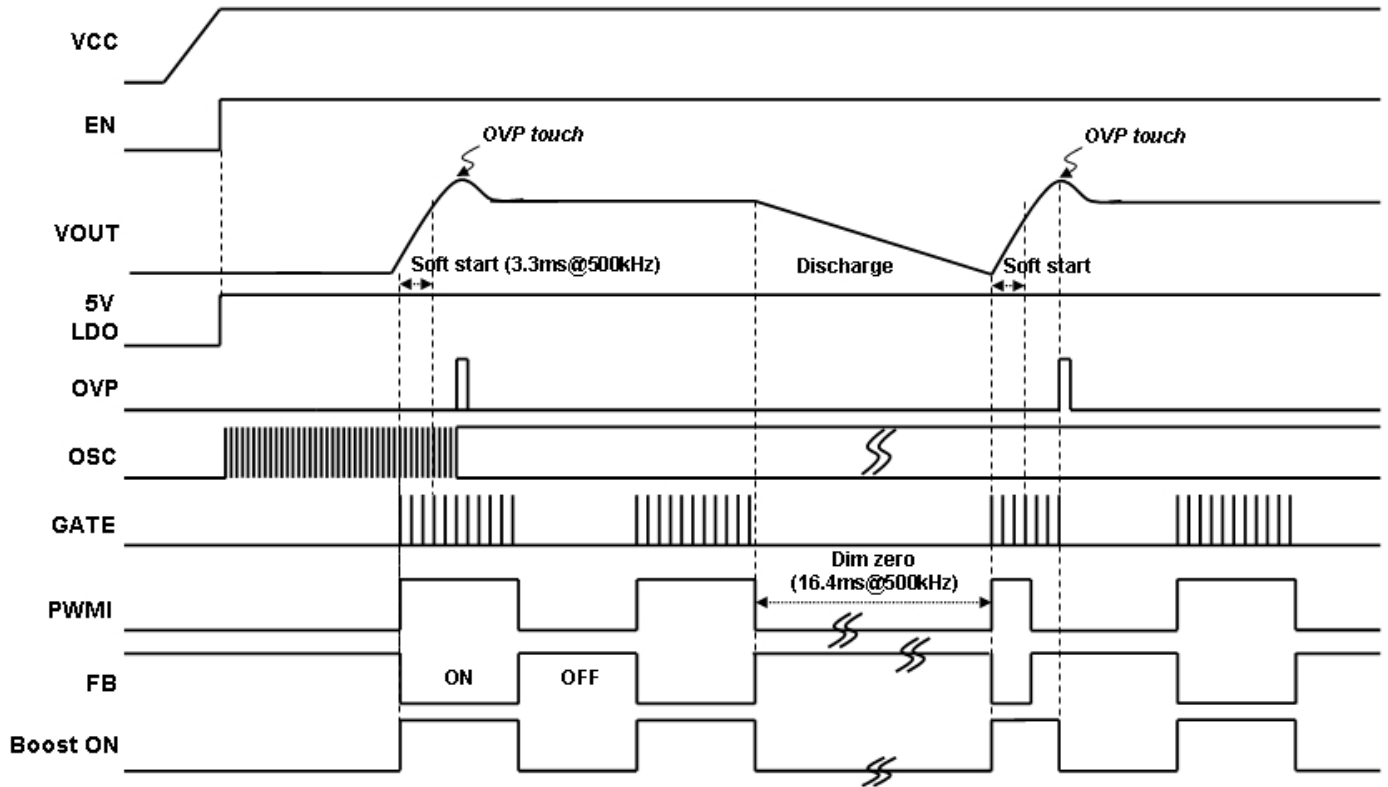

After the enable turns on, the internal 5V LDO is powered up and the internal oscillator starts oscillation. If the PWMI signal remains low at the initial state, the gate drive output to the external MOSFET also remains low, so the boost controller does not step up the output voltage. As soon as the PWMI signal turns on over than at least 1% duty cycle, the controller performs soft-start and continues regulation throughout the PWMI on duty. In the meantime each FB's are turned on simultaneously and the constant current flows the LEDs. The timing between PWMI and FB is approximately same.

If the PWMI signal remains low state over than 16.4ms at 500kHz boost switching frequency during normal operation, the controller regards it as dim-zero condition. Because of discharge of output capacitor through the OVP sensing resistors during the dim-zero time, the output voltage getting declined. So the controller performs soft-start to boost the output voltage until it reaches the over-voltage-protection level with regarding the dimming duty cycle as 100%. For this reason, some extra switching can be seen when the on duty of PWMI signal is less than the internal boost on period.

## EXTERNAL COMPONENTS SELECTION

### Inductor

The inductor value should be decided before system design. Because the selection of the inductor affects the operating mode of CCM(Continuous Conduction Mode) or DCM(Discontinuous Conduction Mode). In CCM operation, inductor size should be bigger, even though the ripple current and peak current of inductor can be small. In DCM operation, even ripple current and peak current of inductor should be large while the inductor size can be smaller.

The inductor DC current or input current can be calculated as following equations.

$$I_{IN} = \frac{V_{OUT} \times I_{OUT}}{V_{IN} \times \eta}$$

$\eta$  – Efficiency of the boost converter

Then the duty ratio is,

$$D = \frac{V_{OUT} - V_{IN} + V_D}{V_{OUT} + V_D}$$

$V_D$  – Forward voltage drop of the output rectifying diode

When the boost converter runs in DCM ( $L < L_{critical}$ ), it takes the advantages of small inductance and quick transient response. The inductor peak current is,

$$I_{L\_peak\_DCM} = \frac{V_{IN} \times D}{f_{SW} \times L}$$

The converter will work in CCM if  $L > L_{critical}$ , generally the converter has higher efficiency under CCM and the inductor peak current is,

$$I_{L\_peak\_CCM} = I_{IN} + \frac{V_{IN} \times D}{2 f_{SW} \times L}$$

### Input Capacitor

In boost converter, input current flows continuously into the inductor; AC ripple component is only proportional to the rate of the inductor charging, thus, smaller value input capacitors may be used. Ensure the voltage rating of the input capacitor is suitable to handle the full supply range.

A capacitor with low ESR should be chosen to minimize heating effects and improve system efficiency, such as X5R or X7R ceramic capacitors.

### Output Capacitor

The output capacitor acts to smooth the output voltage and supplies load current directly during the conduction phase of the power switch. Output ripple voltage consists of the discharge of the output capacitor during the FET ton period and the voltage drop due to load current flowing through the ESR of the output capacitor. The ripple voltage is shown in following equation.

$$\Delta V_{OUT} = \frac{I_{OUT} \times D}{C_{OUT} \times f_{SW}} + I_{OUT} \times ESR$$

Assume a ceramic capacitor is used. The minimum capacitance needed for a given ripple can be estimated by following equation.

$$C_{OUT} = \frac{(V_{IN} - V_{OUT}) \times I_{OUT}}{V_{OUT} \times f_{SW} \times \Delta V_{OUT}}$$

### Output Rectifying Diode

Schottky diodes are the ideal choice for MAP3204 due to their low forward voltage drop and fast switching speed. Make sure that the diode has a voltage rating greater than the possible maximum output voltage. The diode conducts current only when the power switch is turned off.

### Loop Compensation

The MAP3204 controls in current mode. Current mode easily achieves compensation by consisting simple single pole from double pole that LC filter makes at voltage mode. In general, crossover frequency is selected from 1/3 ~ 1/6 range of the switching frequency. If  $f_c$  is large, there is possibility of oscillation to occur, although time response gets better.

On the other hand, if  $f_c$  is small, time response will be bad, while it has improved stability, which may cause over shoot or under shoot in abnormal condition.



Physical Dimensions

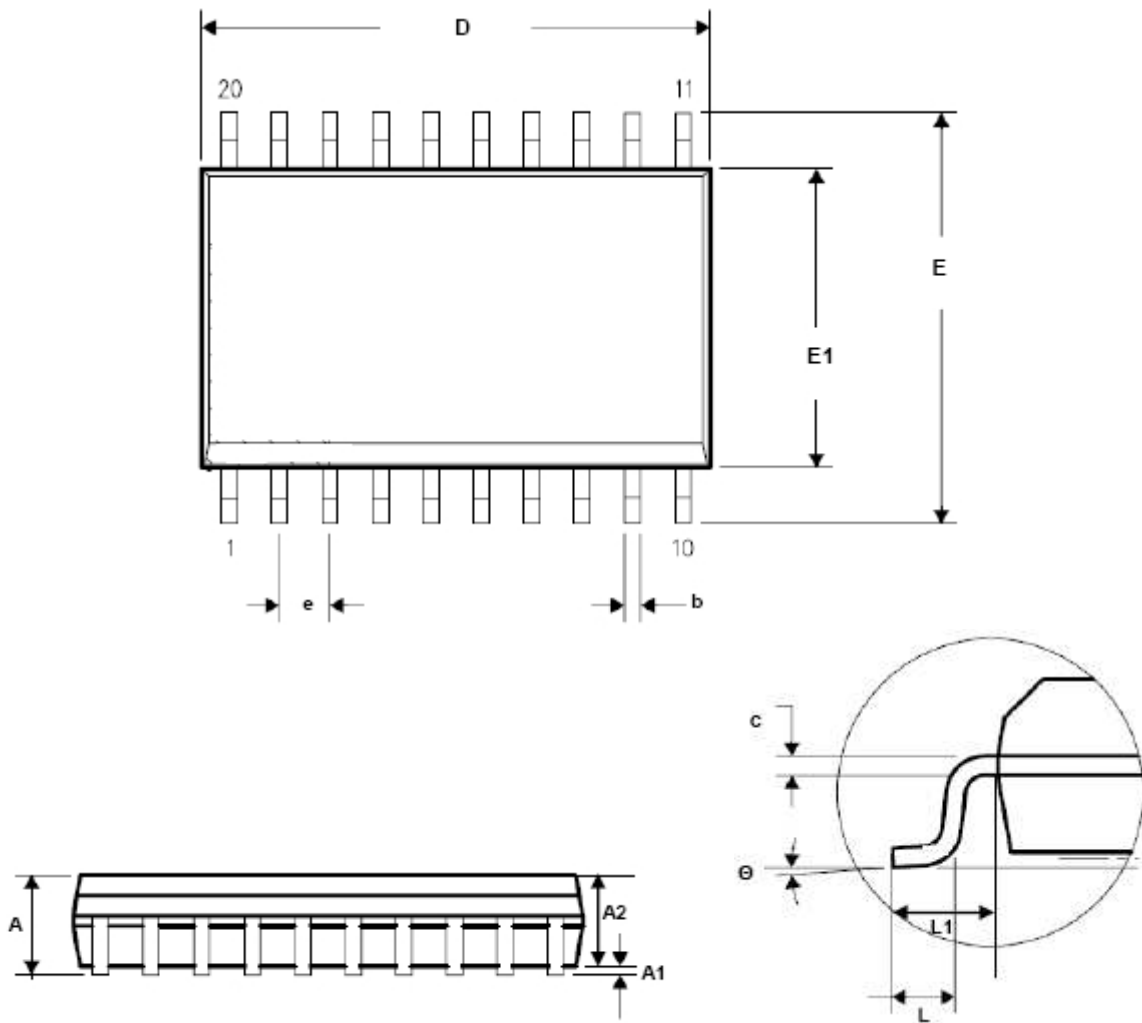

20 Leads SOIC  
(Top view)

Symbol	Dimension		
	Min	Norm	Max
A			2.65
A1	0.05		0.30
A2	2.05		2.40
b	0.31		0.51
c	0.20		0.33
D	12.54		13.00
E			
E1	7.30		7.70
e	1.27 BSC		
L	0.40		1.27
L1	1.40 REF		
theta	0°		8°

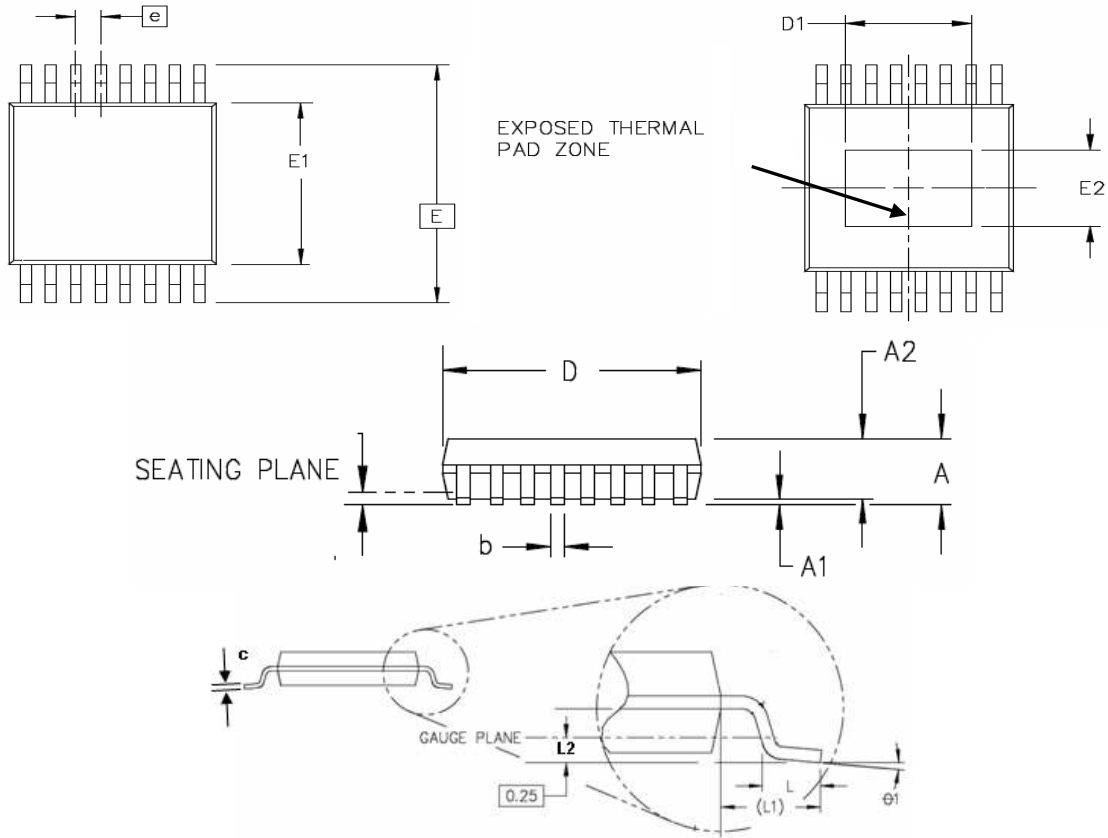

16 Leads TSSOP  
(Top view)

Symbol	Dimension		
	Min	Norm	Max
A			1.20
A1	0.00		0.15
A2	0.80		1.05
b	0.19		0.30
C	0.09		0.20
D	4.90		5.10
D1	1.70		
E	6.40 BSC		
E1	4.30		4.50
E2	1.50		
e	0.65 BSC		
L	0.45		0.75
L1	1.00 REF		
L2	0.25 REF		
θ1	0°		8°

MagnaChip Semiconductor Ltd. doesn't not recommend the use of its products in hostile environments, including, without limitation, aircraft, nuclear power generation, medical appliances, and devices or systems in which malfunction of any product can reasonably be expected to result in a personal injury. Seller's customers using or selling Seller's products for use in such applications do so at their own risk and agree to fully defend and indemnify Seller.

MagnaChip reserves the right to change the specifications and circuitry without notice at any time. MagnaChip does not consider responsibility for use of any circuitry other than circuitry entirely included in a MagnaChip product.

MagnaChip is a registered trademark of MagnaChip Semiconductor Ltd.

**MagnaChip Semiconductor Ltd.**

891, Daechi-Dong, Kangnam-Gu, Seoul, 135-738 Korea

Tel : 82-2-6903-3451 / Fax : 82-2-6903-3668 ~9

[www.magnachip.com](http://www.magnachip.com)

**Revision History**

Date	Version	Changes
2010-11-01	Version 0.0	Initial release