



# MAX3679A Evaluation Kit

## General Description

The MAX3679A evaluation kit (EV kit) is an assembled demonstration board that provides convenient evaluation of the MAX3679A low-jitter, precision clock generator. The EV kit includes an on-board 25MHz crystal to allow immediate testing.

The EV kit includes switches to allow easy selection of different modes of operation. The reference input and clock outputs use SMA connectors and are AC-coupled to simplify connection to test equipment.

## Features

- ◆ AC-Coupled I/Os for Ease of Testing
- ◆ Fully Assembled and Tested
- ◆ +3.3V Power-Supply Operation
- ◆ On-Board 25MHz Crystal

## Ordering Information

PART	TYPE
MAX3679AEVKIT+	EV Kit

+Denotes lead(Pb)-free and RoHS compliant.

## Component List

DESIGNATION	QTY	DESCRIPTION
C1, C3, C4, C5, C7–C10, C19, C25–C30, C54	16	0.1 $\mu$ F $\pm$ 10% ceramic capacitors (0402)
C2	1	10 $\mu$ F $\pm$ 10% ceramic capacitor (0603)
C6, C57–C60	5	0.01 $\mu$ F $\pm$ 10% ceramic capacitors (0402)
C22	1	27pF $\pm$ 10% ceramic capacitor (0402)
C23	1	33pF $\pm$ 10% ceramic capacitor (0402)
C65	1	4.7pF $\pm$ 10% ceramic capacitor (0402)
J1, J3, J5	0	Not installed
J2, J48	2	Test points
J4	1	2-pin header, 0.1in centers
J13–J16, J18, J19, J36, J43	8	SMA connectors
L1	1	2.7 $\mu$ H inductor
R1–R5, R7	6	150 $\Omega$ $\pm$ 5% resistors (0402)
R6, R8, R9	0	Not installed

DESIGNATION	QTY	DESCRIPTION
R42	1	499 $\Omega$ $\pm$ 1% resistor (0402)
R57	1	49.9 $\Omega$ $\pm$ 1% resistor (0402)
R59	1	10.5 $\Omega$ $\pm$ 1% resistor (0402)
R61	1	36 $\Omega$ $\pm$ 5% resistor (0402)
SW1, SW2, SW3, SW11	4	SP3T switches
SW4, SW6, SW9, SW12, SW13, SW15	6	SPDT switches
TP6, TP7	2	Test points
U1	1	+3.3V, low-jitter crystal to LVPECL clock generator (32 TQFN-EP*) Maxim MAX3679AETJ+
Y1	1	25MHz crystal NDK EXS00A-AT00429
—	1	Shunt
—	1	PCB: MAX3679A EVALUATION BOARD+, REV A

\*EP = Exposed pad.

+Denotes a lead(Pb)-free/RoHS-compliant package.

## Component Supplier

SUPPLIER	PHONE	WEBSITE
NDK America	815-544-7900	www.ndk.com/en

**Note:** Indicate that you are using the MAX3679A when contacting this component supplier.



# MAX3679A Evaluation Kit

## Quick Start

For evaluation of the MAX3679A, configure the EV kit as follows:

- 1) Determine which output is going to be evaluated and connect to the test equipment through SMA cables. Be sure not to leave any outputs unterminated (i.e., place 50Ω terminators on all unused outputs).
- 2) Connect a +3.3V power supply to J48 (VCC) and J2 (GND). Set the current limit to 200mA.
- 3) If the on-board crystal is used, set IN\_SEL to HIGH.
- 4) Use Table 2 to set the output divider switches to achieve the output frequency desired.
- 5) Enable the output under test by setting the related output-enable switch (Qx\_OE) HIGH.

**Table 1. Adjustment and Control Descriptions (see Quick Start first)**

COMPONENT	NAME	FUNCTION
J4	INDUCTOR SHUNT	J4 shunts the power-supply inductor. Normal operation is J4 shunted.
SW1	SELB1	SW1 and SW2 set the output divider for the QB outputs. See Table 2 for more information.
SW2	SELB0	SW1 and SW2 set the output divider for the QB outputs. See Table 2 for more information.
SW3	SELA1	SW3 and SW11 set the output divider for the QA outputs. See Table 2 for more information.
SW4	QAC_OE	Set HIGH to enable the LVCMOS output, QA_C. Set LOW to disable QA_C.
SW6	$\overline{\text{BYPASS}}$	Set LOW to bypass the PLL. Set HIGH to engage the PLL. Note that when the PLL is bypassed the output dividers are automatically set to divide by 1.
SW9	QA_OE	Set HIGH to enable LVPECL output QA. Set LOW to force a logic zero at QA.
SW11	SELA0	SW3 and SW11 set the output divider for the QA outputs. See Table 2 for more information.
SW12	QB1_OE	Set HIGH to enable LVPECL output QB1. Set LOW to force a logic zero at QB1.
SW13	IN_SEL	Set HIGH to select the crystal as the frequency source. Set LOW to select the REF_IN as the frequency source.
SW15	QB0_OE	Set HIGH to enable LVPECL output QB0. Set LOW to force a logic zero at QB0.

**Table 2. Output Divider Settings**

INPUT		NA/NB DIVIDER	OUTPUT FREQUENCY (25MHz CRYSTAL)
SELA1/SELB1	SELA0/SELB0		
LOW	LOW	÷2	312.5
HIGH	LOW	÷4	156.25
HIGH	HIGH	÷5	125
LOW	OPEN	÷10	62.5

# MAX3679A Evaluation Kit

Evaluates: MAX3679A

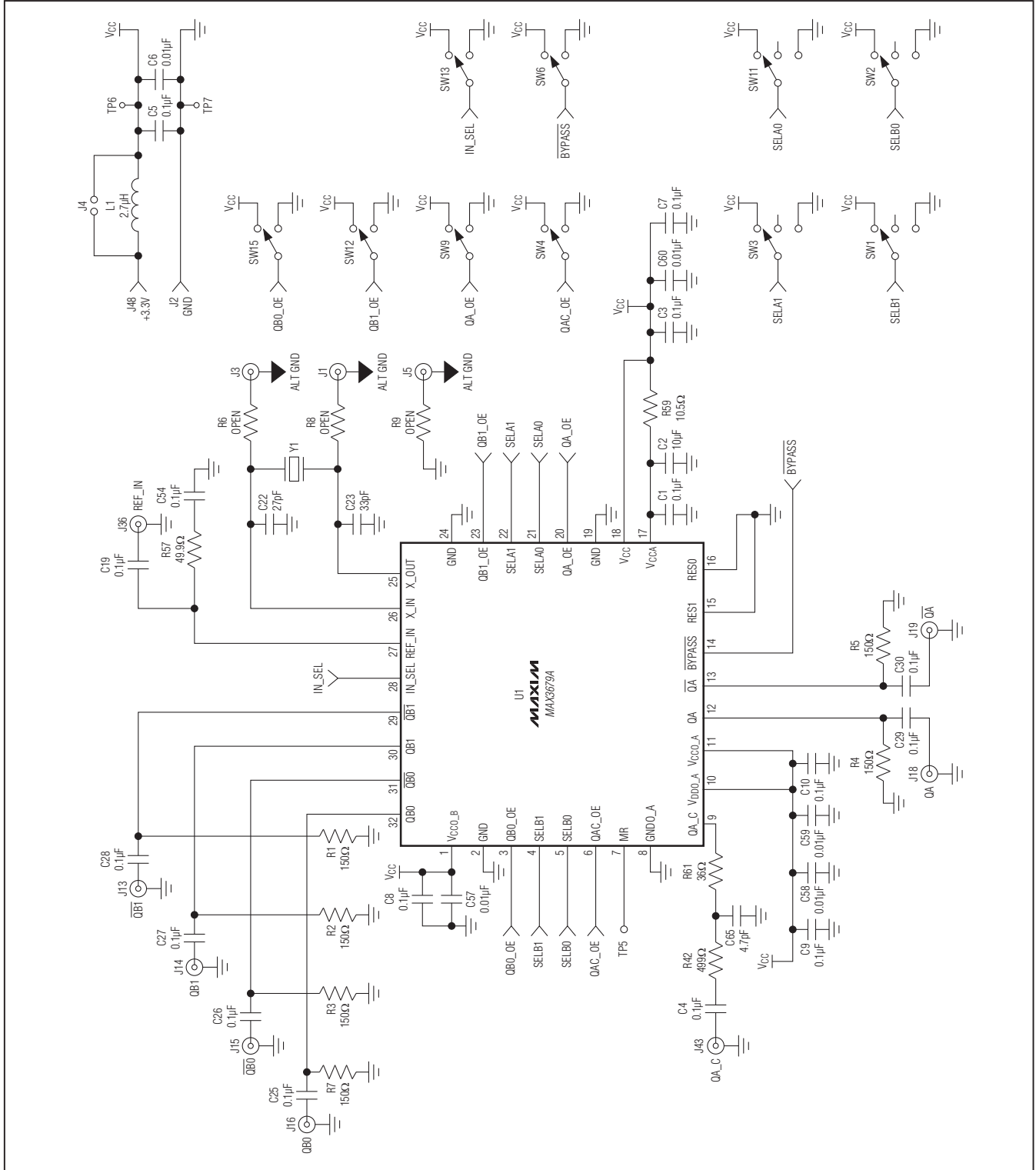

Figure 1. MAX3679A EV Kit Schematic

# MAX3679A Evaluation Kit

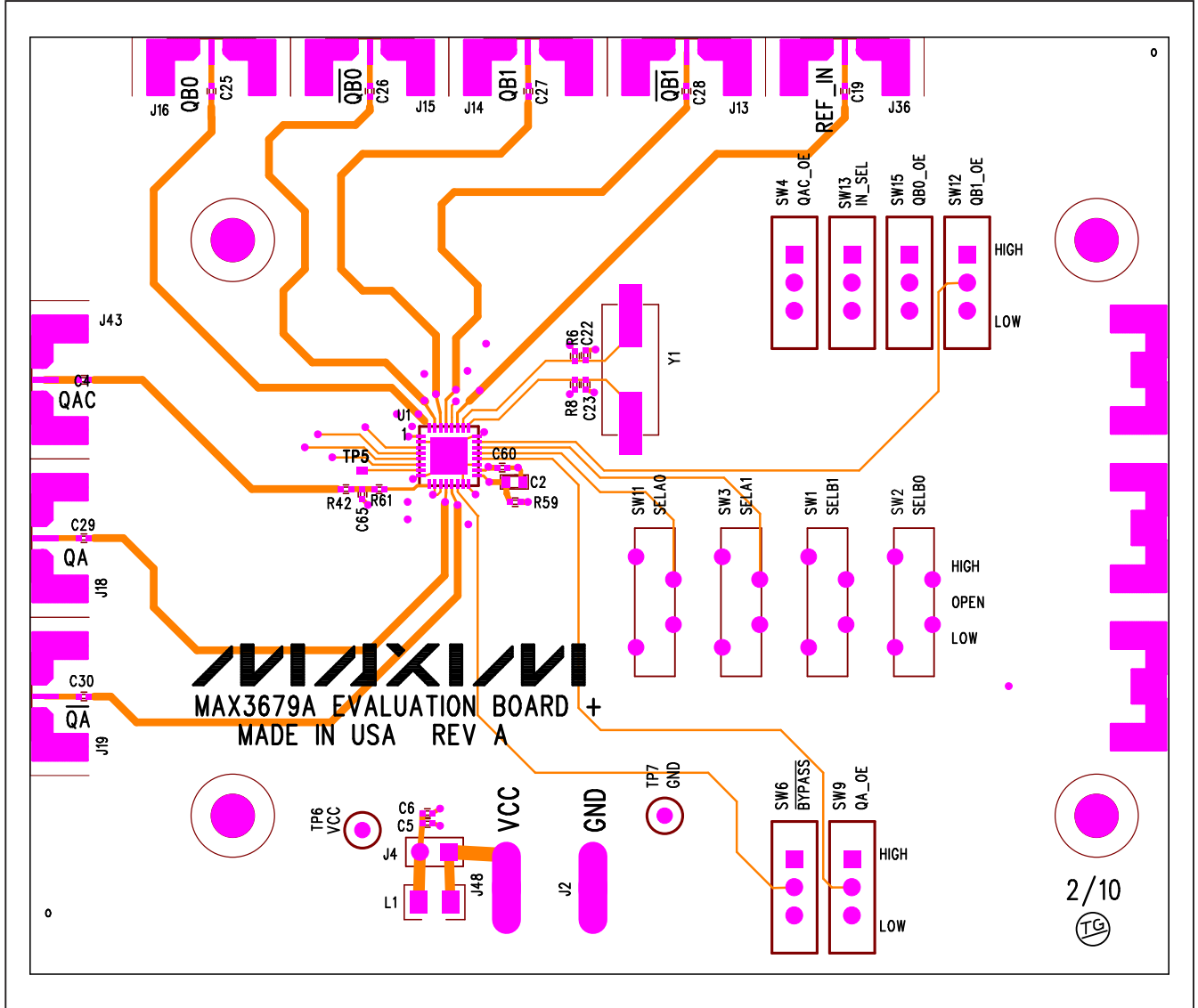

Figure 2. MAX3679A EV Kit Assembly Drawing—Top Side

# MAX3679A Evaluation Kit

Evaluates: MAX3679A

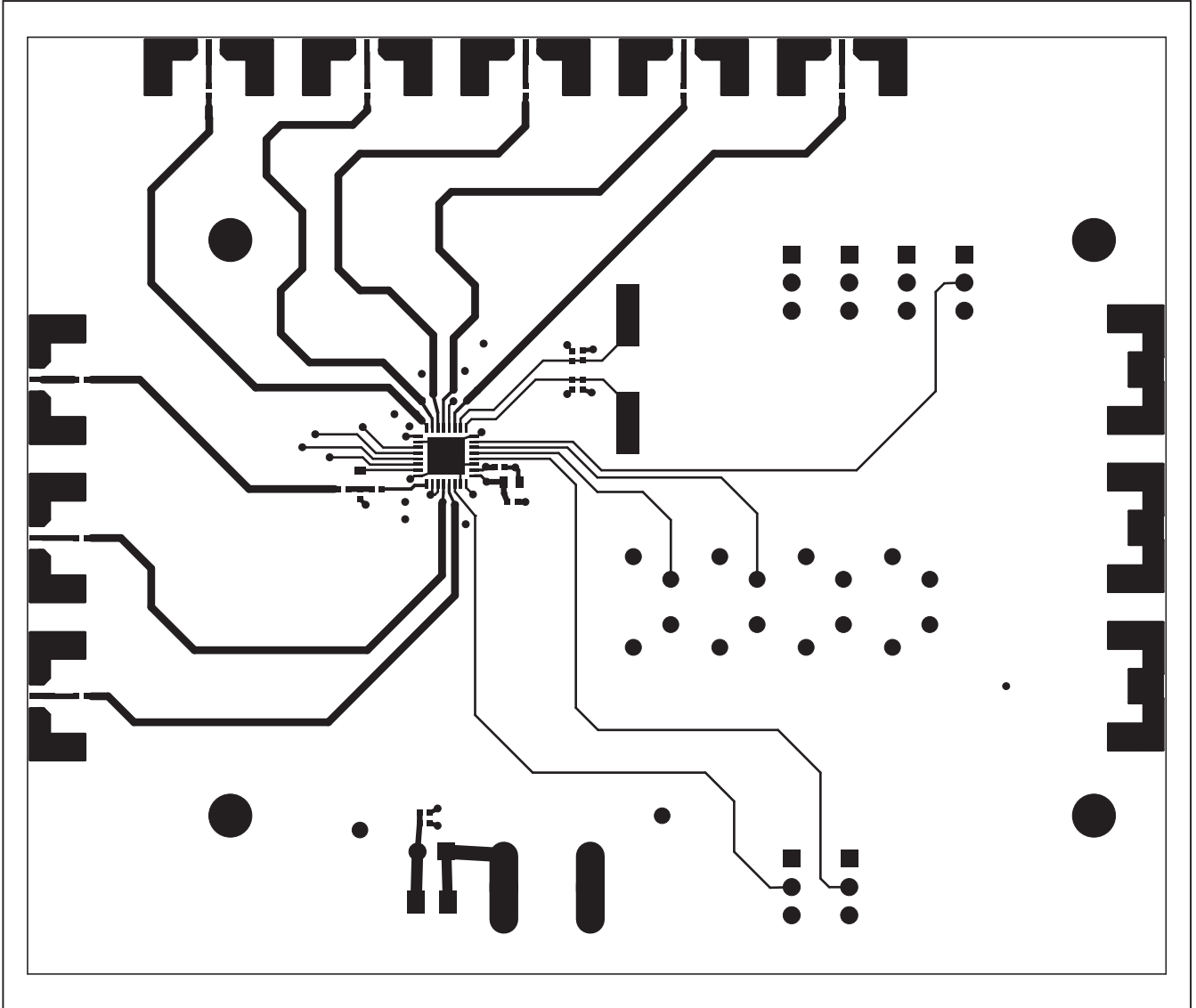

Figure 3. MAX3679A EV Kit Layout—Component Side

# MAX3679A Evaluation Kit

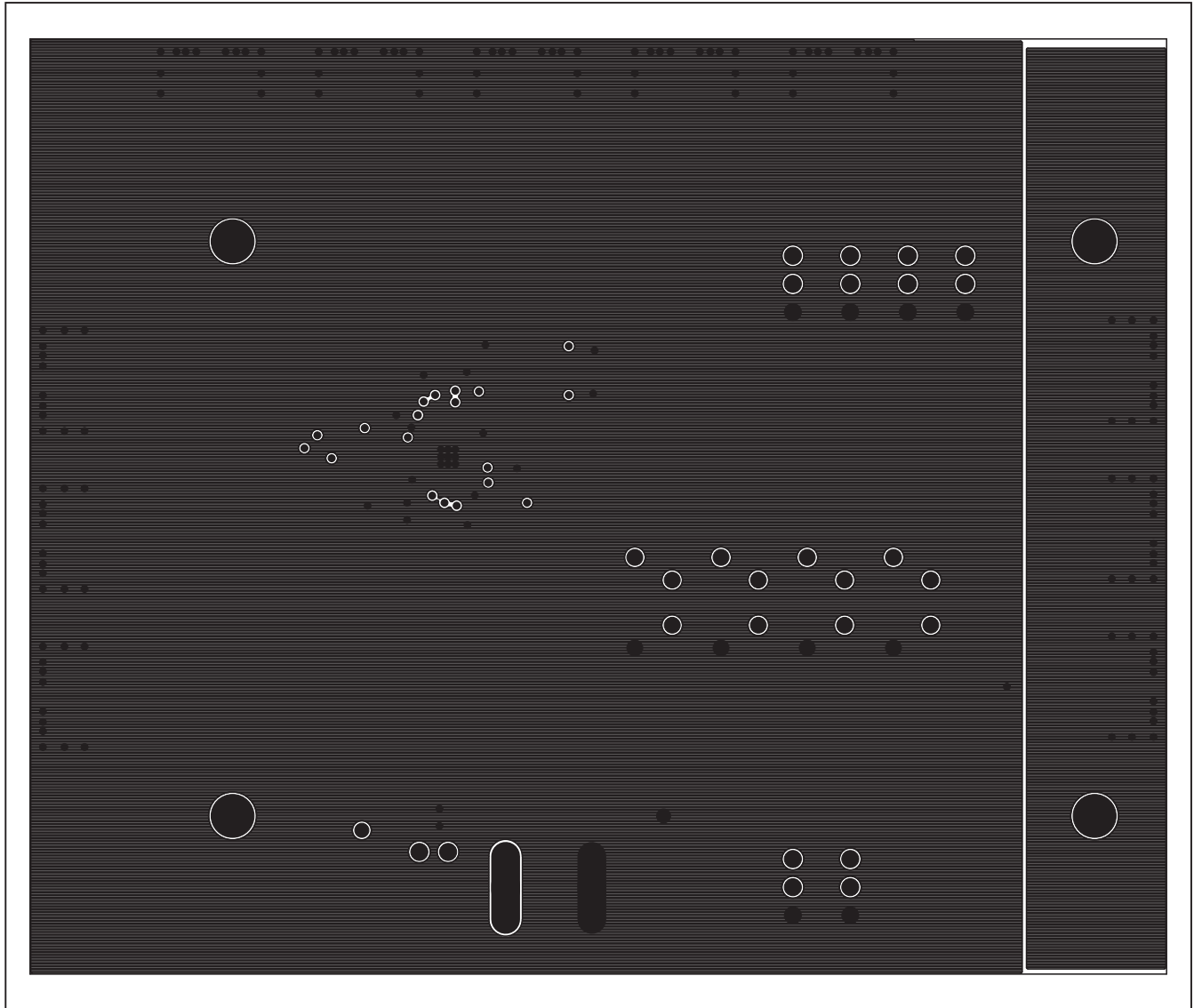

Figure 4. MAX3679A EV Kit Layout—Ground Plane

# MAX3679A Evaluation Kit

Evaluates: MAX3679A

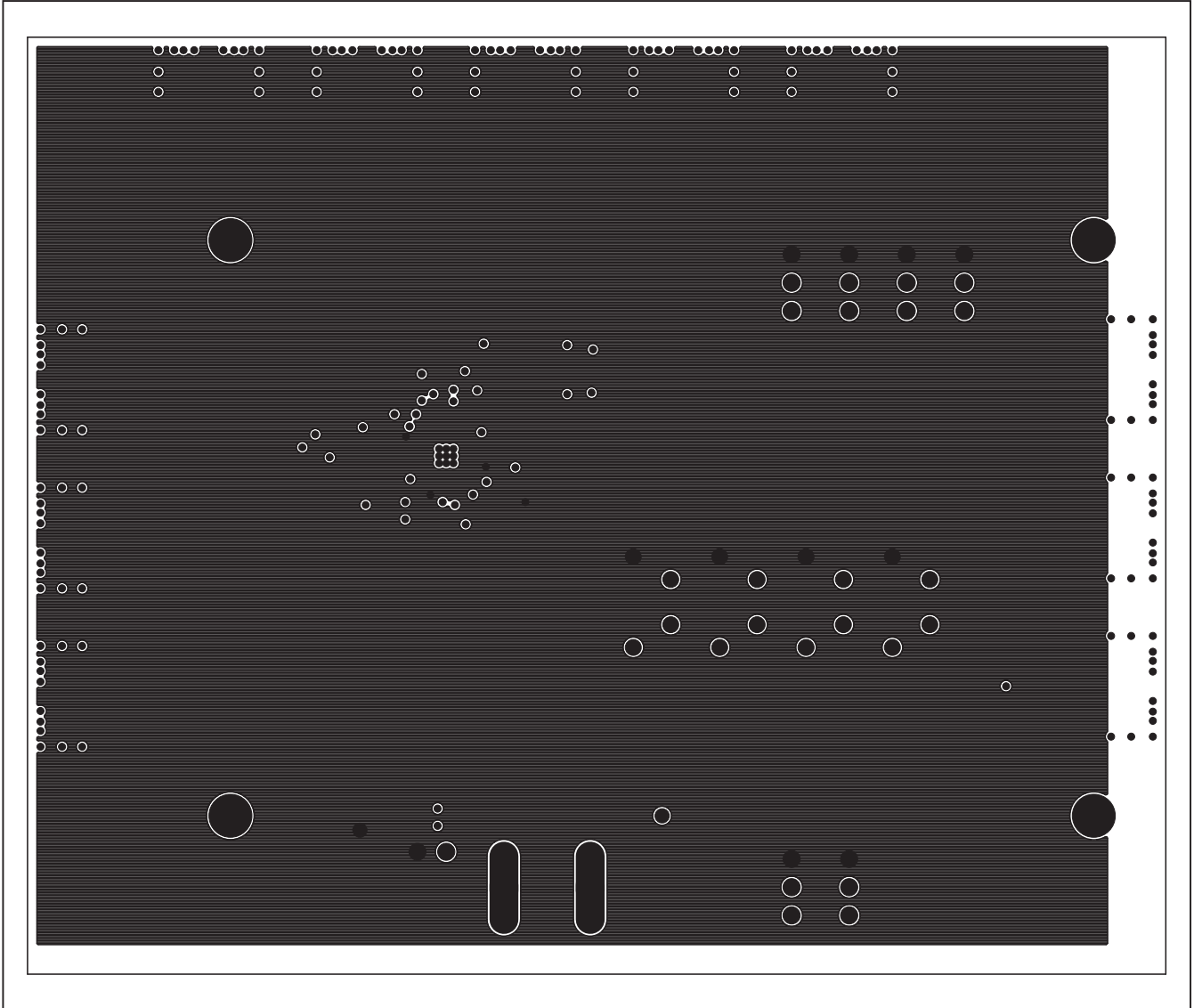

Figure 5. MAX3679A EV Kit Layout—Power Plane

# MAX3679A Evaluation Kit

Evaluates: MAX3679A

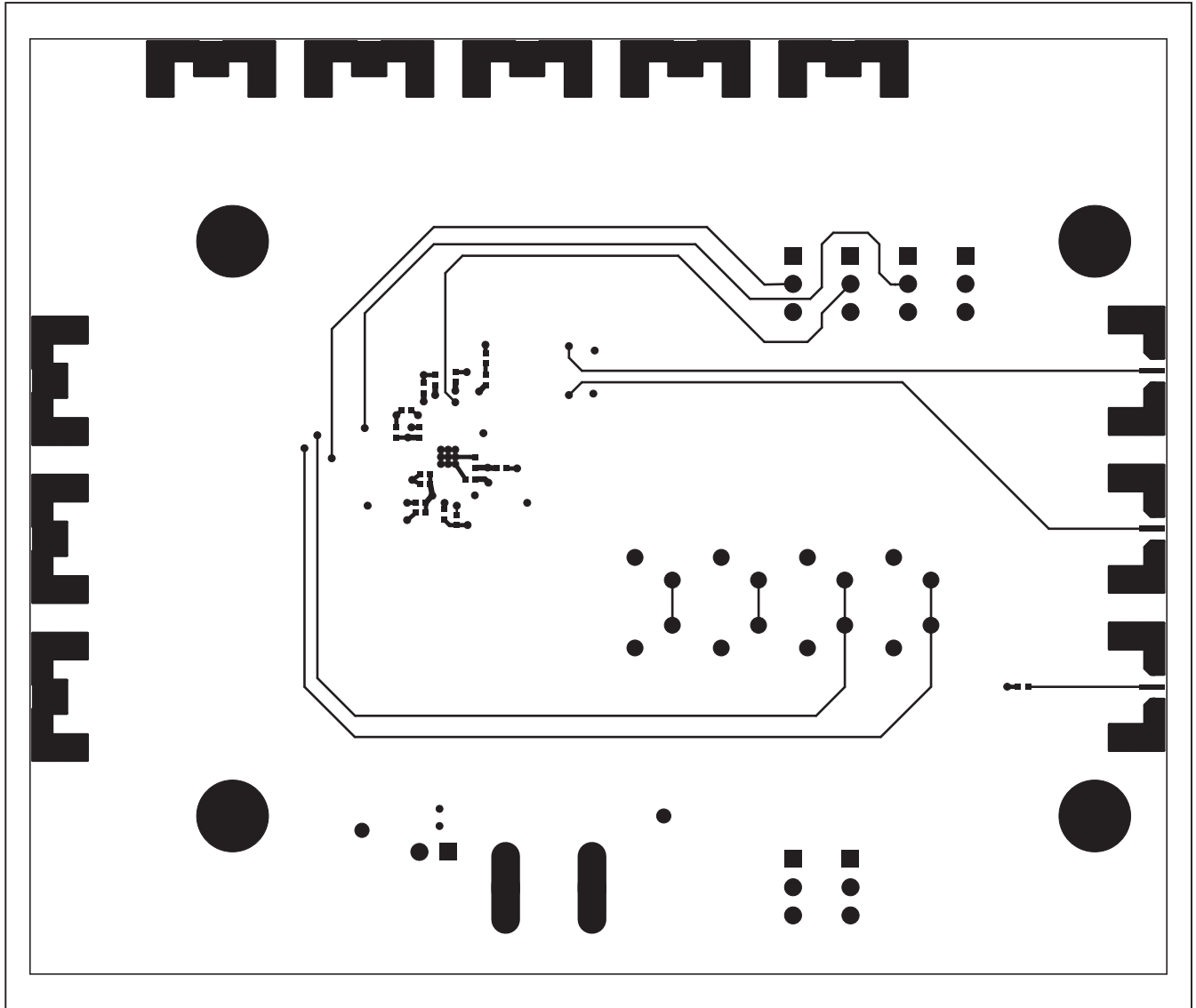

Figure 6. MAX3679A EV Kit Layout—Solder Side



# MAX3679A Evaluation Kit

Evaluates: MAX3679A

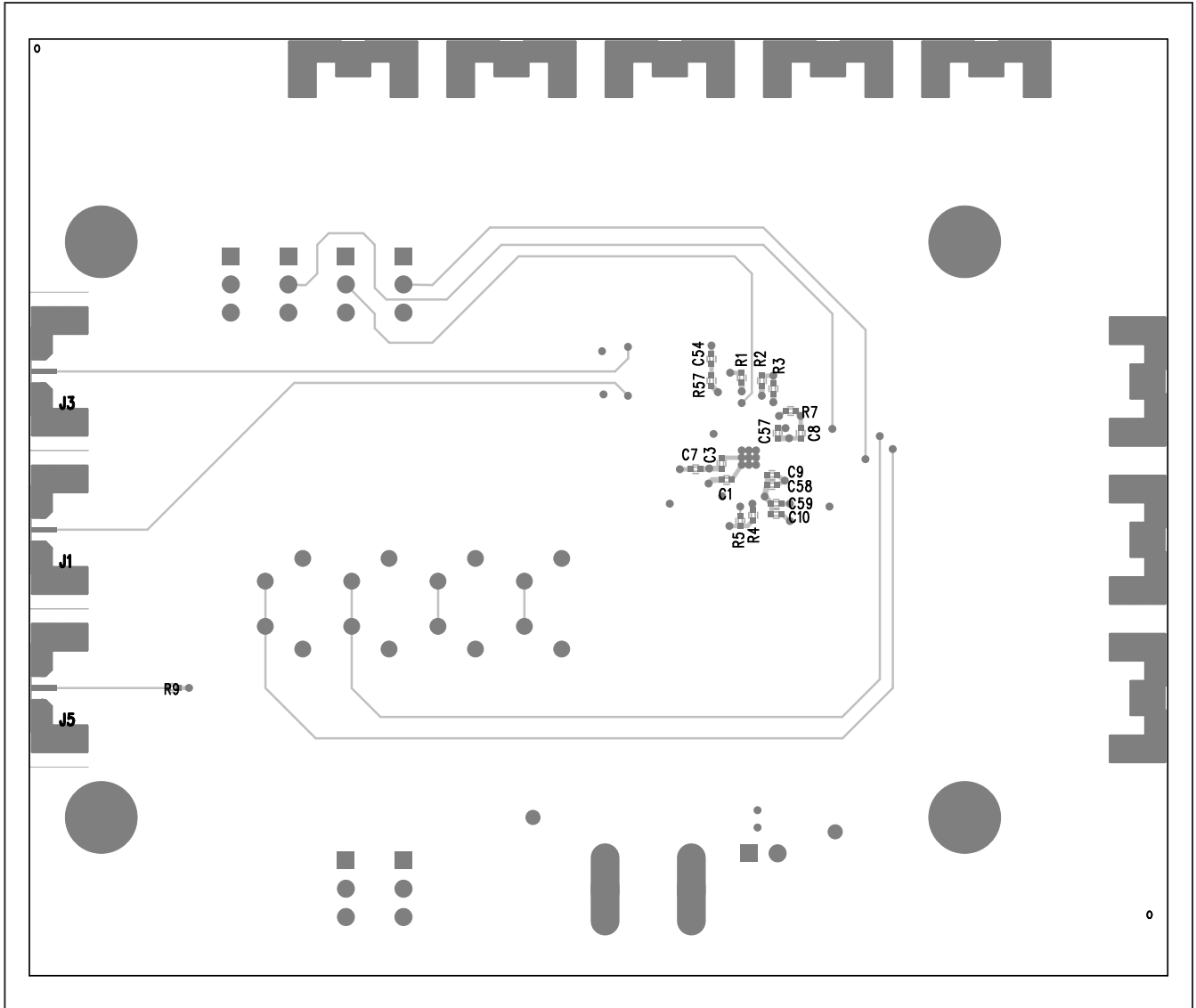

Figure 7. MAX3679A EV Kit Assembly Drawing—Bottom Side

Maxim cannot assume responsibility for use of any circuitry other than circuitry entirely embodied in a Maxim product. No circuit patent licenses are implied. Maxim reserves the right to change the circuitry and specifications without notice at any time.

Maxim Integrated Products, 120 San Gabriel Drive, Sunnyvale, CA 94086 408-737-7600 \_\_\_\_\_ 9