

SCHOTTKY BARRIER RECTIFIERS

REVERSE VOLTAGE - **30 to 60** Volts
FORWARD CURRENT - **16** Amperes

FEATURES

- Metal of silicon rectifier, majority carrier conduction
- Guard ring for transient protection
- Low power loss, high efficiency
- High current capability, low VF
- High surge capacity
- Plastic package has UL flammability classification 94V-0
- For use in low voltage, high frequency inverters, free-wheeling, and polarity protection applications

MECHANICAL DATA

- Case : TO-220AC molded plastic
- Polarity : As marked on the body
- Weight : 0.08 ounces, 2.24 grams
- Mounting position : any
- Max. mounting torque = 0.5 N.m (5.1 Kgf.cm)

TO-220AC

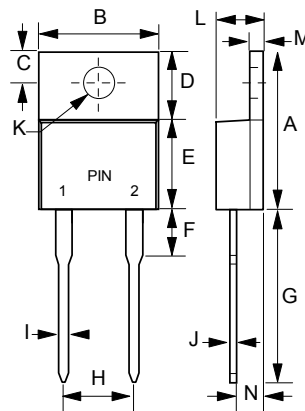

TO-220AC		
DIM.	MIN.	MAX.
A	14.22	15.88
B	9.65	10.67
C	2.54	3.43
D	5.84	6.86
E	8.26	9.28
F	-	6.35
G	12.70	14.73
H	4.83	5.33
I	0.51	1.14
J	0.30	0.64
K	3.53 \varnothing	4.09 \varnothing
L	3.56	4.83
M	1.14	1.40
N	2.03	2.92

All Dimensions in millimeter

MAXIMUM RATINGS AND ELECTRICAL CHARACTERISTICS

Ratings at 25°C ambient temperature unless otherwise specified.

CHARACTERISTICS	SYMBOL	MBR1630	MBR1635	MBR1640	MBR1645	MBR1650	MBR1660	UNIT
Maximum Recurrent Peak Reverse Voltage	VRRM	30	35	40	45	50	60	V
Maximum RMS Voltage	VRMS	21	24.5	28	31.5	35	42	V
Maximum DC Blocking Voltage	VDC	30	35	40	45	50	60	V
Maximum Average Forward Rectified Current (See Fig.1)	I(AV)	16						A
Peak Forward Surge Current 8.3ms single half sine-wave superimposed on rated load	IFSM	150						A
Voltage Rate of Change (Rated VR)	dv/dt	10000				1000		V/us
Maximum Forward Voltage (Note 1)	VF	IF=16A @ TJ=25°C		0.63		0.75		V
		IF=16A @ TJ=125°C		0.57		0.65		V
Maximum DC Reverse Current at Rated DC Blocking Voltage	IR	@TJ=25°C		0.2		1		mA
		@TJ=125°C		40		50		
Typical Thermal Resistance (Note 2)	RθJC	1.5				3		°C/W
Typical Junction Capacitance (Note 3)	CJ	450						pF
Operating Temperature Range	TJ	-55 to +150						°C
Storage Temperature Range	TSTG	-55 to +175						°C

- NOTES : 1. 300us Pulse width , 2% duty cycle.
2. Device mounted on 150*150*3mm copper plate.
3. Measured at 1.0MHz and applied reverse voltage of 4.0V DC.

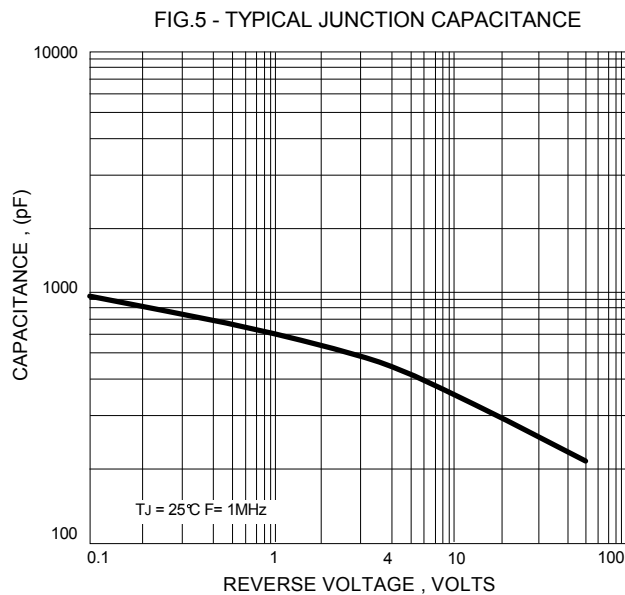
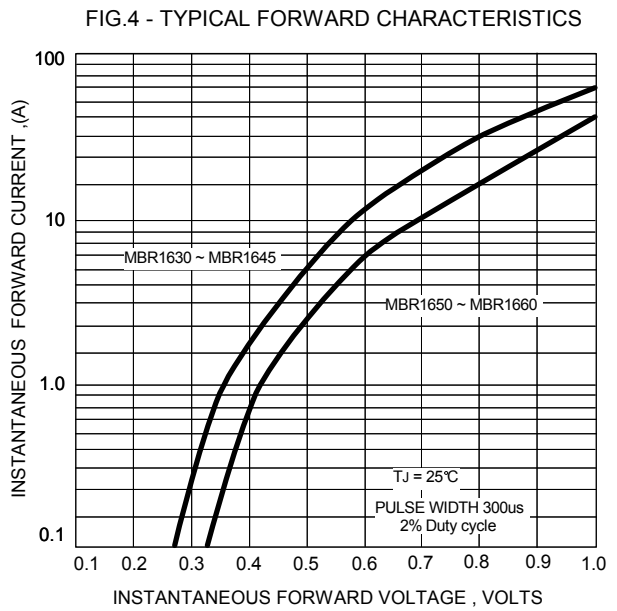
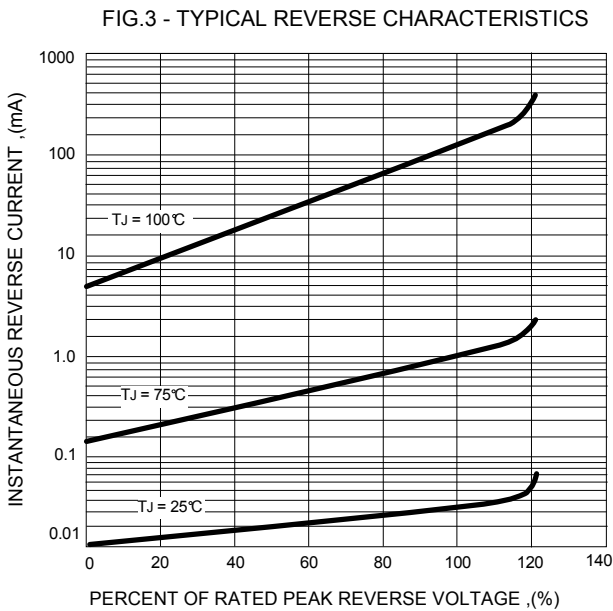
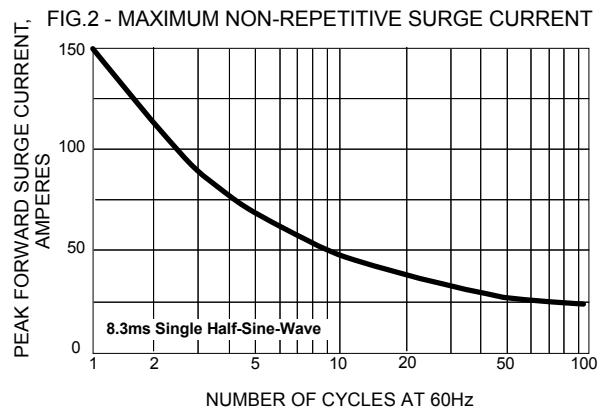
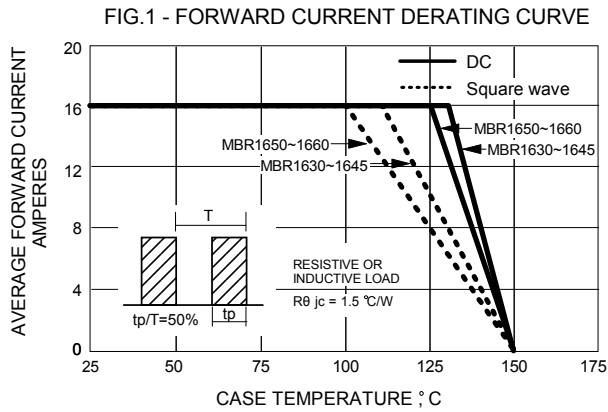

Important Notice and Disclaimer

LSC reserves the right to make changes to this document and its products and specifications at any time without notice. Customers should obtain and confirm the latest product information and specifications before final design, purchase or use.

LSC makes no warranty, representation or guarantee regarding the suitability of its products for any particular purpose, nor does LSC assume any liability for application assistance or customer product design. LSC does not warrant or accept any liability with products which are purchased or used for any unintended or unauthorized application.

No license is granted by implication or otherwise under any intellectual property rights of LSC.

LSC products are not authorized for use as critical components in life support devices or systems without express written approval of LSC.