

Schottky Barrier Rectifier

MBRB2060CT

FEATURES

- Schottky barrier chip
- Low Power Loss, High Efficiency
- Guard ring for transient protection
- High Operating Junction Temperature
- 100% avalanche tested
- Minimum Lot-to-Lot variations for robust device performance and reliable operation

APPLICATIONS

- For use in high frequency rectifier of switching mode power supplies, freewheeling diodes, DC-to-DC converters or polarity protection application.

ABSOLUTE MAXIMUM RATINGS(Ta=25°C)

SYMBOL	PARAMETER	VALUE	UNIT
VRRM VRMS VR	Peak Repetitive Reverse Voltage RMS Voltage DC Blocking Voltage	60	V
IF(AV)	Average Rectified Forward Current	20	A
IFSM	Nonrepetitive Peak Surge Current 8.3ms single half sine-wave superimposed on rated load conditions	150	A
TJ	Junction Temperature	-65~150	°C
Tstg	Storage Temperature Range	-65~175	°C

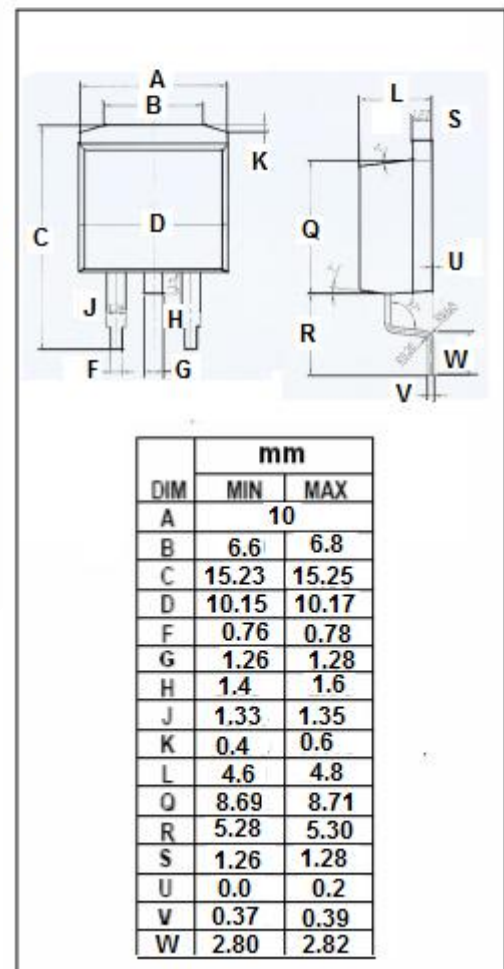
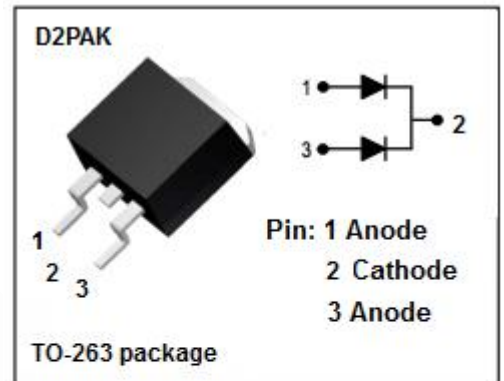

**Schottky Barrier Rectifier****MBRB2060CT****THERMAL CHARACTERISTICS**

SYMBOL	PARAMETER	MAX	UNIT
$R_{th\ j-c}$	Thermal Resistance, Junction to Case	2.0	$^{\circ}C/W$

**ELECTRICAL CHARACTERISTICS**

SYMBOL	PARAMETER			CONDITIONS	TYP	MAX	UNIT
$V_F$	Maximum Voltage	Instantaneous	Forward	$I_F=10A ; T_j=25^{\circ}C$		0.80	V
				$I_F=10A ; T_j=125^{\circ}C$		0.70	
				$I_F=20A ; T_j=25^{\circ}C$		0.95	
				$I_F=20A ; T_j=125^{\circ}C$		0.85	
$I_R$	Maximum Current	Instantaneous	Reverse	$V_R= V_{RWM}; T_j=25^{\circ}C$		150	$\mu A$
				$V_R= V_{RWM}; T_j=125^{\circ}C$		150	mA