

### SCHOTTKY BARRIER RECTIFIER

VOLTAGE RANGE: 20 --- 200 V  
CURRENT: 5.0A

#### FEATURES

- ◇ Metal-semiconductor junction with guard ring
- ◇ Epitaxial construction
- ◇ Low forward voltage drop, low switching losses
- ◇ High surge capability
- ◇ For use in low voltage, high frequency inverters free wheeling, and polarity protection applications
- ◇ The plastic material carries U/L recognition 94V-0

#### MECHANICAL DATA

- ◇ Case: JEDEC ITO-220AC, molded plastic
- ◇ Terminals: Axial lead, solderable per MIL-STD-750, Method 2026
- ◇ Polarity: As marked
- ◇ Weight: 0.08 ounces, 2.24 grams
- ◇ Mounting position: Any

#### ITO - 220AC

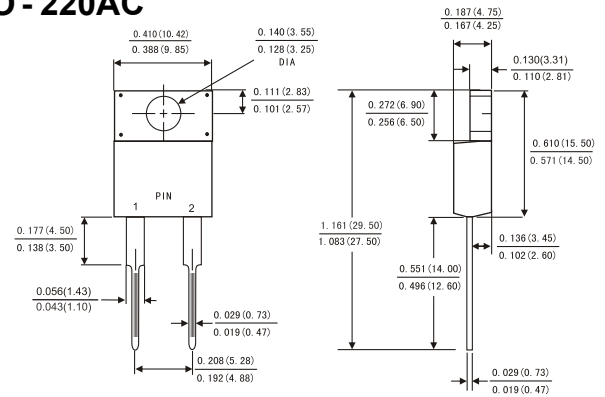

Dimensions in inches and (millimeters)

#### MAXIMUM RATINGS AND ELECTRICAL CHARACTERISTICS

Ratings at 25°C ambient temperature unless otherwise specified.

Single phase, half wave, 60 Hz, resistive or inductive load. For capacitive load, derate by 20%.

	Symbols	MBRF 520	MBRF 530	MBRF 540	MBRF 550	MBRF 560	MBRF 580	MBRF 5A0	MBRF 5150	MBRF 5200	Units	
Maximum repetitive peak reverse voltage	V <sub>RRM</sub>	20	30	40	50	60	80	100	150	200	Volts	
Maximum RMS voltage	V <sub>RMS</sub>	14	21	28	35	42	57	71	105	140	Volts	
Maximum DC blocking voltage	V <sub>DC</sub>	20	30	40	50	60	80	100	150	200	Volts	
Maximum average forward rectified current 0.375"(9.5mm) lead length(see fig.1)	I(AV)	5.0									Amps	
Peak forward surge current 8.3ms single half sine-wave superimposed on rated load (JEDEC method at rated T <sub>J</sub> )	I <sub>FSM</sub>	150.0									Amps	
Maximum instantaneous forward voltage at 5.0 A(Note 1)	V <sub>F</sub>	0.60		0.75		0.85		0.90		0.95	Volts	
Maximum instantaneous reverse current at rated DC blocking voltage(Note 1)	I <sub>R</sub>	0.2									mA	
		50			25							
Typical junction capacitance(Note 3)	C <sub>J</sub>	500			400						pF	
Typical thermal resistance (Note 2)	R <sub>θJA</sub>	25.0										°C/W
	R <sub>θJL</sub>	8.0										
Operating junction temperature range	T <sub>J</sub>	-65 to +150									°C	
Storage temperature range	T <sub>STG</sub>	-65 to +150									°C	

- NOTE: 1. Pulse test: 300us pulse width, 1% duty cycle.  
2. Measured at 1.0MHz and applied reverse voltage of 4.0V DC.  
3. Thermal resistance junction to ambient

FIG.1-FORWARD CURRENT DERATING CURVE

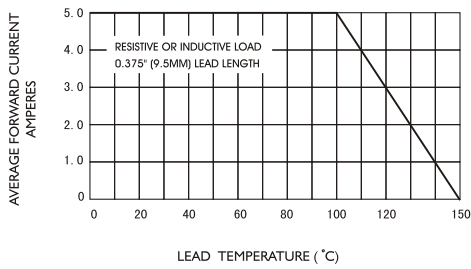

FIG.2-MAXIMUM NON-REPETITIVE PEAK FORWARD SURGE CURRENT

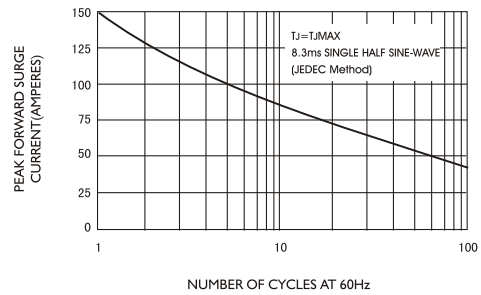

FIG.3-TYPICAL INSTANTANEOUS FORWARD CHARACTERISTICS

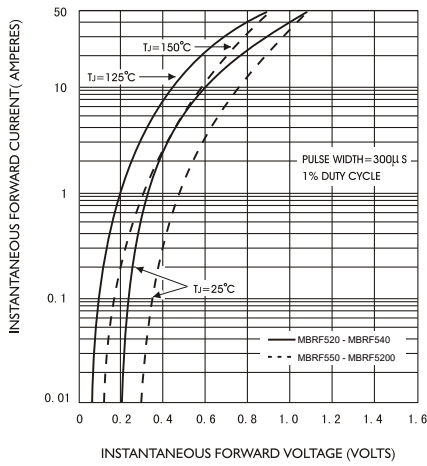

FIG.4-TYPICAL REVERSE CHARACTERISTICS

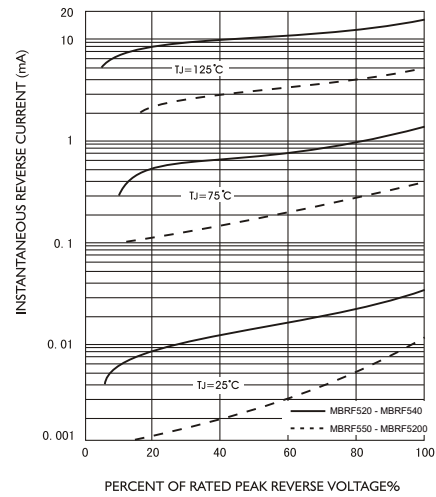

FIG.5-TYPICAL JUNCTION CAPACITANCE

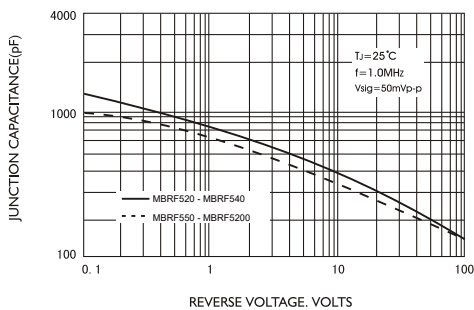

FIG.6-TYPICAL TRANSIENT THERMAL IMPEDANCE

