

Quad Line Driver

The MC1488 is a monolithic quad line driver designed to interface data terminal equipment with data communications equipment in conformance with the specifications of EIA Standard NO. EIA-232D.

Features:

- Current Limited Output $\pm 10\text{mA}$ typical
- Power-Off Source Impedance 300Ω minimum
- Simple Slow Rate Control With External Capacitor
- Flexible Operating Supply Range
- Compatible with All Motorola MDTL and MTTL Logic Families

P SUFFIX
PLASTIC PACKAGE
CASE 646

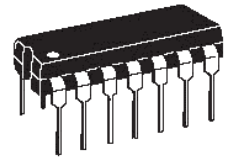

D SUFFIX
PLASTIC PACKAGE
CASE 751A
(SO-14)

ORDERING INFORMATION

Device	Operating Temperature Range	Package
MC1488P	$T_A=0$ to $+75$	Plastic
MC1488D		SO-14

Simplified Application

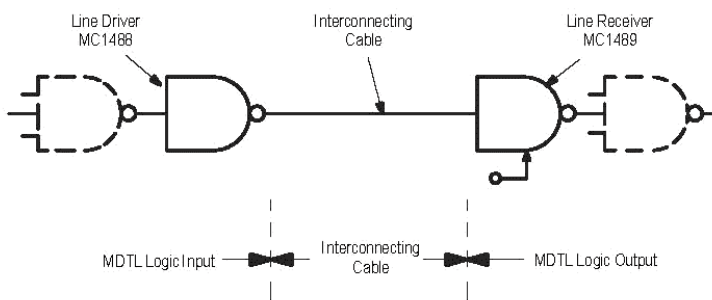

PIN CONNECTIONS

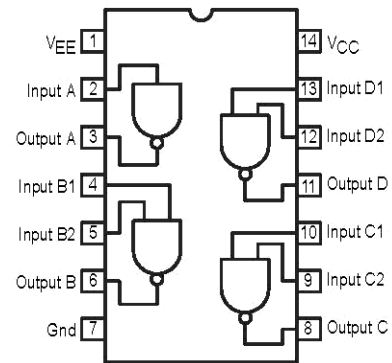

Circuit Schematic

(1/4 of Circuit Shown)

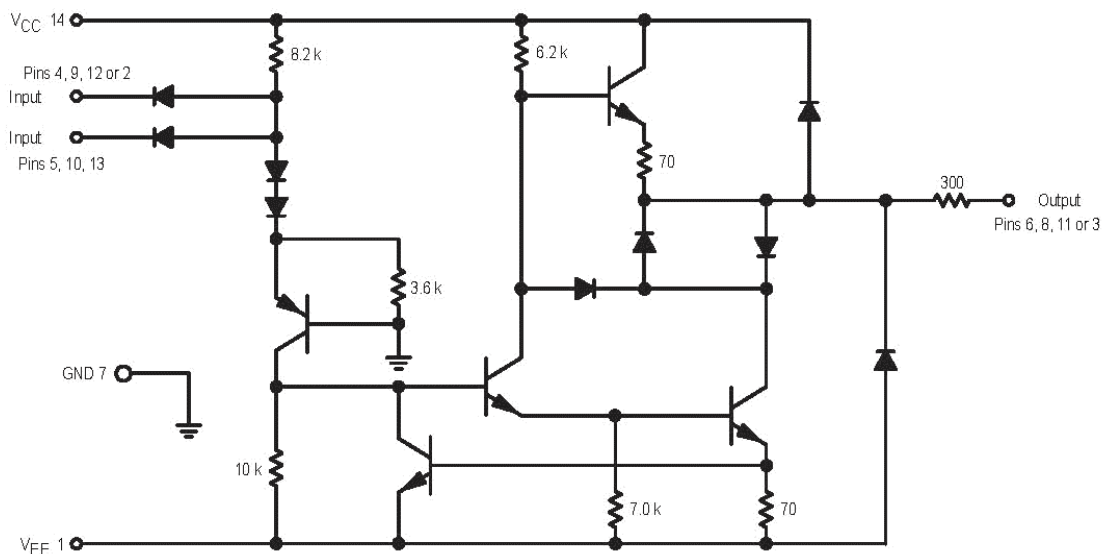

MAXIMUM RATINGS (TA=+25 , unless otherwise noted.)

Rating	Symbol	Value	Unit
Power Supply Voltage	V _{CC} V _{EE}	+15 -15	Vdc
Input Voltage Range	V _{IR}	-15 ≤ V _{IR} ≤ 7.0	Vdc
Output Signal Voltage	V _O	±15	Vdc
Power Derating (Package Limitation, So-14 and Plastic Dual-In-Line Package) Derate above T _A =+25	P _D 1/R _{θJA}	1000 6.7	mW mW/
Operating Ambient Temperature Range	T _A	0 to +75	
Storage Temperature Range	T _{stg}	-65 to +175	

ELECTRICAL CHARACTERISTICS (V_{CC}=+9.0±1% Vdc, V_{EE}=-9.0±1% Vdc, T_A=0 to 75 , unless otherwise noted.)

Characteristic	Symbol	Min	Typ	Max	Unit
Input Current – Low Logic State (V _{IL} =0)	I _{IL}	-	1.0	1.6	mA
Input Current – High Logic State (V _{IH} =5.0V)	I _{IH}	-	-	10	μA
Output Voltage – High Logic State (V _{IL} =0.8Vdc, R _L =3.0kΩ, V _{CC} =+9.0Vdc, V _{EE} =-9.0Vdc) (V _{IL} =0.8 Vdc, R _L =3.0kΩ, V _{CC} =+13.2Vdc, V _{EE} =-13.2Vdc)	V _{OH}	+6.0 +9.0	+7.0 +10.5	- -	Vdc
Output Voltage –Low logic State (V _{IH} =1.9Vdc, R _L =3.0kΩ, V _{CC} =+9.0 Vdc, V _{EE} =-9.0Vdc) (V _{IH} =1.9Vdc, R _L =3.0kΩ, V _{CC} =+13.2Vdc, V _{EE} =-13.2Vdc)	V _{OL}	-6.0 -9.0	-7.0 -10.5	- -	Vdc
Positive Output Short-Circuit Current, Note 1	I _{OS+}	+6.0	+10	+12	mA
Negative Output Short-Circuit Current, Note 1	I _{OS-}	-6.0	-10	-12	mA
Output Resistance (V _{CC} =V _{EE} =0, V _O =±2.0V)	r _O	300	-	-	Ohms
Positive Supply Current (R _L =∞) (V _{IH} =1.9Vdc, V _{CC} =+9.0 Vdc) (V _{IL} =0.8Vdc, V _{CC} =+9.0Vdc) (V _{IH} =1.9Vdc, V _{CC} =+12Vdc) (V _{IH} =0.8Vdc, V _{CC} =+12Vdc) (V _{IH} =1.9Vdc, V _{CC} =+15Vdc) (V _{IL} =0.8Vdc, V _{CC} =+15Vdc)	I _{CC}	- - - - - -	+15 +4.5 +19 +5.0 - -	+20 +6.0 +25 +7.0 +34 +12	mA
Negative Supply Current (R _L =∞) (V _{IH} =1.9Vdc, V _{EE} =-9.0 Vdc) (V _{IL} =0.8Vdc, V _{EE} =-9.0Vdc) (V _{IH} =1.9Vdc, V _{EE} =-12Vdc) (V _{IH} =0.8Vdc, V _{EE} =-12Vdc) (V _{IH} =1.9Vdc, V _{EE} =-15Vdc) (V _{IL} =0.8Vdc, V _{EE} =-15Vdc)	I _{EE}	- - - - - -	-13 - -18 - - -	-17 -500 -23 -500 -34 -2.5	mA μA mA μA mA mA
Power Consumption (V _{CC} =9.0Vdc, V _{EE} =-9.0Vdc) (V _{CC} =12Vdc, V _{EE} =-12Vdc)	P _C	- -	- -	333 576	mW

SWITCHING CHARACTERISTICS (V_{CC}=+9.0±1% Vdc, V_{EE}=-9.0 ±1% Vdc, T_A=+25 .)

Propagation Delay Time (Z _I =3.0k and 15pF)	t _{PLH}	-	275	350	ns
Fall Time (Z _I =3.0k and 15pF)	t _{THL}	-	45	75	ns
Propagation Delay Time (Z _I =3.0k and 15pF)	t _{PHL}	-	110	175	ns
Rise Time (Z _I =3.0k and 15pF)	t _{TLH}	-	55	100	ns

NOTE:1. Maximum Package Power Dissipation may be exceeded if all outputs are shorted simultaneously.

CHARACTERISTIC DEFINITIONS

Figure 1. Input Current

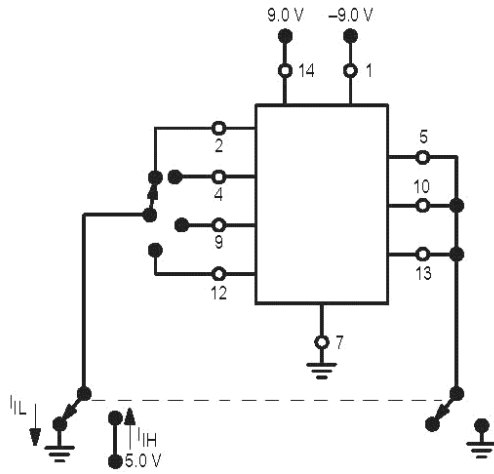

Figure 2. Output Voltage

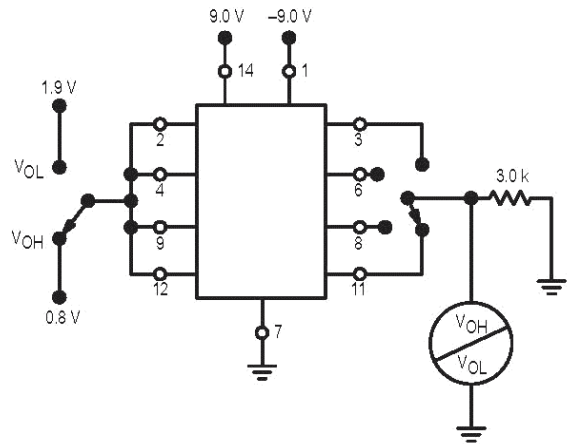

Figure 3. Output Short-Circuit Current

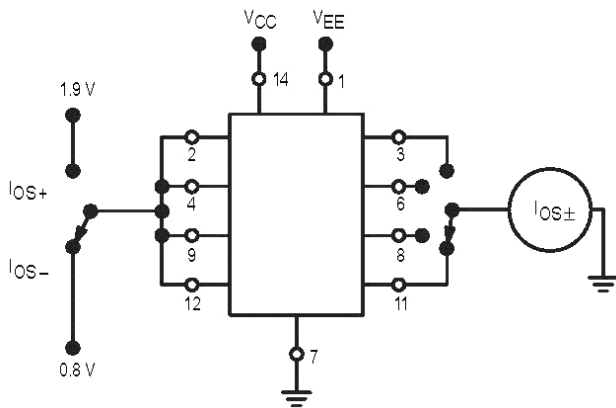

Figure 4. Output Resistance (Power Off)

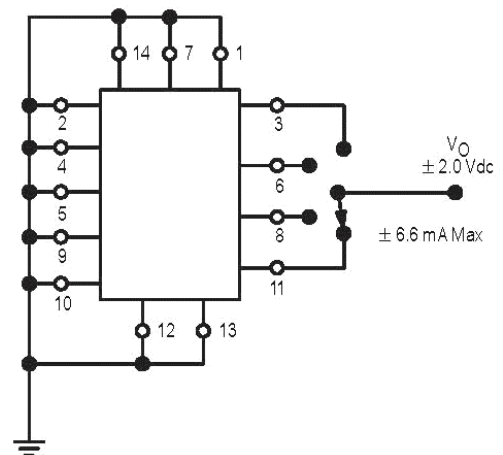

Figure 5. Power Supply Current

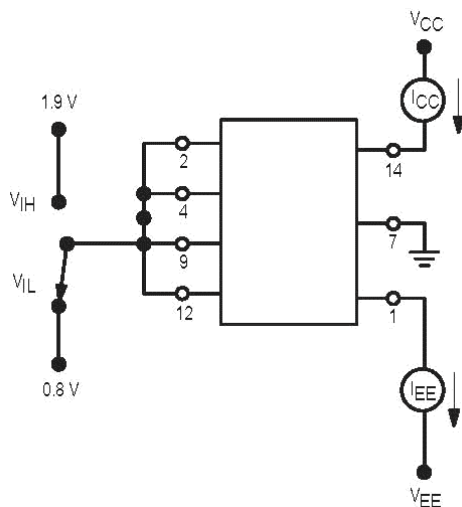
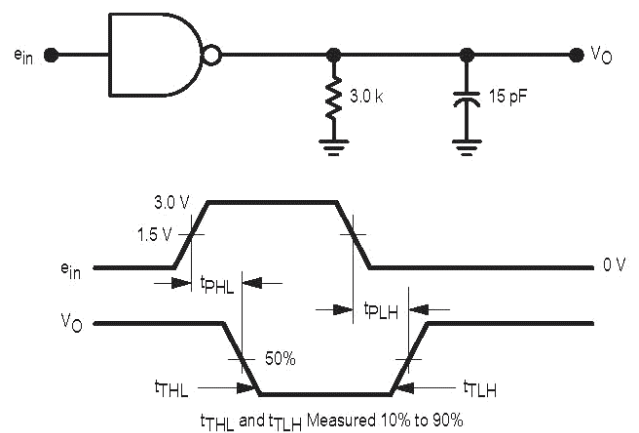

Figure 6. Switching Response



TYPICAL CHARACTERISTICS

($T_A = +25^\circ\text{C}$, unless otherwise noted.)

Figure 7. Transfer Characteristics
Versus Power Supply Voltage

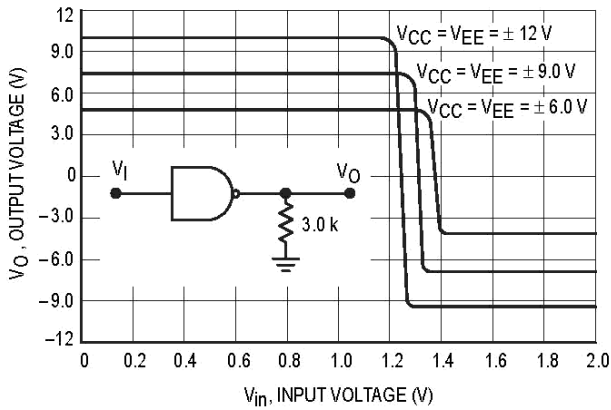

Figure 8. Short Circuit Output Current
Versus Temperature

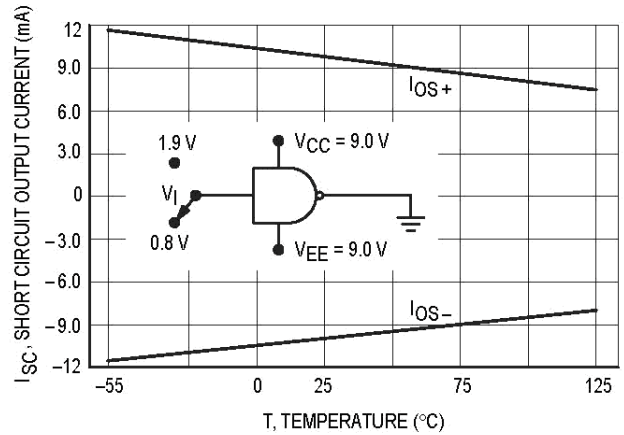

Figure 9. Output Slew Rate
Versus Load Capacitance

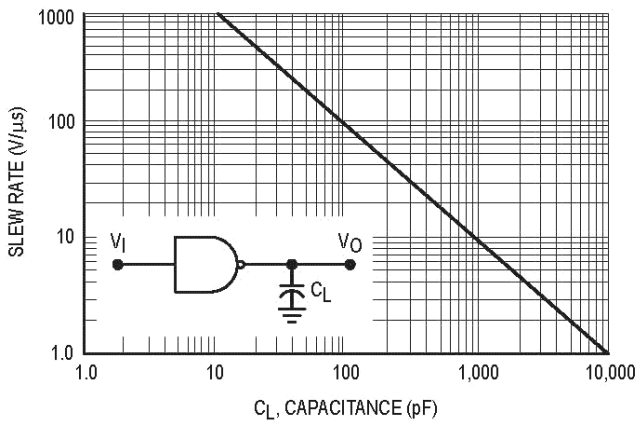

Figure 10. Output Voltage and
Current-Limiting Characteristics

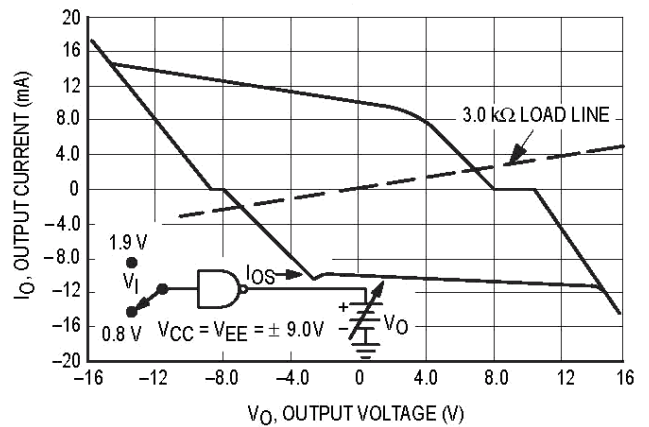
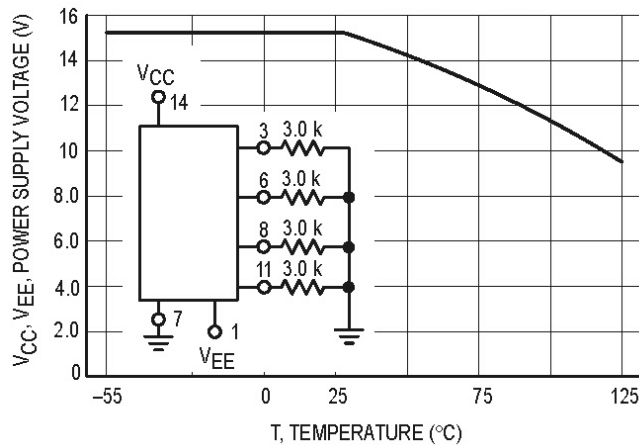

Figure 11. Maximum Operating Temperature
Versus Power Supply Voltage



APPLICATIONS INFORMATION

The Electronic Industries Association EIA-232D specification details the requirements for the interface between data processing equipment and data communications equipment. This standard specifies not only the number and type of interface leads, but also the voltage levels to be used. The MC1488 quad driver and its companion circuit, the MC1489 quad receiver, provide a complete interface system between DTL or TTL logic levels and the EIA-232D defined levels. The EIA-232D requirements as applied to drivers are discussed herein.

The required driver voltages are defined as between 5.0 and 15V in magnitude and are positive for a Logic "0" and negative for a Logic "1". These voltage are so defined when the drivers are terminated with a 3000 to 7000Ω resistor. The MC1488 meets this voltage requirement by converting a DTL/TTL logic level into EIA-232D levels with one stage of inversion.

The EIA-232D specification further requires that during transitions, the driver output slew rate must not exceed 30V per microsecond. The inherent slew rate of the MC1488 is much too fast for this requirement. The current limited output of the device can be used to control this slew rate by connecting a capacitor to each driver output. The required capacitor can be easily determined by using the relationship $C = I_{OS} \times \Delta T / \Delta V$ from which Figure 12 is derived. Accordingly, a 330pF capacitor on each output will guarantee a worst case slew rate of 30 V per microsecond.

Figure 12. Slew Rate versus Capacitance for $I_{SC}=10mA$

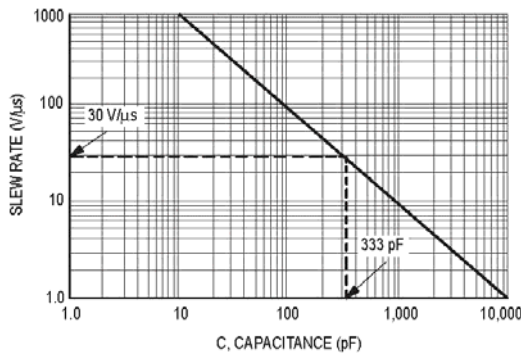

The interface driver is also required to withstand an accidental short to any other conductor in an interconnecting cable. The worst possible signal on any conductor would be another driver using a plus or minus 15V, 500mA source. The MC1488 is designed to indefinitely withstand such a short to all four outputs in a package as long as the power supply voltages are greater than 9.0V (i.e., $V_{CC} \geq 9.0V$; $V_{EE} \leq -9.0V$). In some power supply designs, a loss of system power causes, a low impedance to ground would exist at the power inputs to the MC1488 effectively shorting the 300Ω output resistors to ground. If all four outputs were then shorted to plus or minus 15V, the power dissipation in these resistors would be excessive. Therefore, if the system is designed to permit low impedances to ground at the power supplies of the drivers, a

diode should be placed in each power supply lead to prevent overheating in this fault condition. These two diodes, as shown in Figure 13, could be used to decouple all the driver packages in a system. (These same diodes will allow the MC1488 to withstand momentary shorts to the $\pm 25V$ limits specified in the earlier Standard EIA-232B.) The addition of the diodes also permits the MC1488 to withstand faults with power supplies of less than the 9.0V stated above.

Figure 13. Power Supply Protection to Meet Power Off

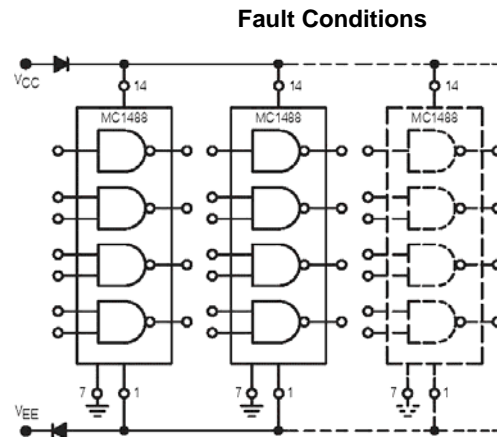

The maximum short circuit current allowable under fault conditions is more than guaranteed by the previously mentioned 10 mA output current limiting.

Other Applications

The MC1488 is an extremely versatile line driver with a myriad of possible applications. Several features of the drivers enhance this versatility:

1. Output Current Limiting – this enables the circuit designer to define the output voltage levels is independent of power supplies and can be accomplished by diode clamping of the output pins. Figure 14 shows the MC1488 used as a DTL to MOS translator where the high level voltage output is clamped one diode above ground. The resistor divider shown is used to reduce the output voltage below the 300mV above ground MOS input level limit.
2. Power Supply Range – as can be seen from the schematic drawing of the drivers, the positives and negative driving elements of the device are essentially independent and do not require matching power supplies. In fact, the positive supply can vary from a minimum 7.0V (required for driving the negative pulldown section) to the maximum specified 15V. The negative supply can vary from approximately -2.5V to the minimum specified -15V. The MC1488 will drive the output to within 2.0 V of the positive or negative supplies as long as the current limits are not exceeded. The combination of the current limiting and supply voltage features allow a wide combination of possible outputs within the same quad package. Thus if only a portion of the four drivers are used for driving EIA-232D lines, the remainder could be used for DTL to MOS or even DTL to DTL translation. Figure 15 shows one such combination.

Figure 14. MDTL/MTTL – to –MOS Translator

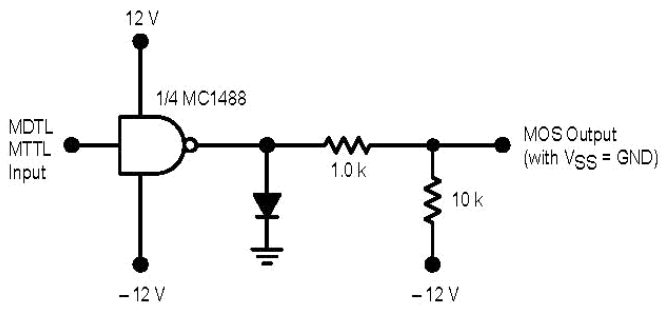
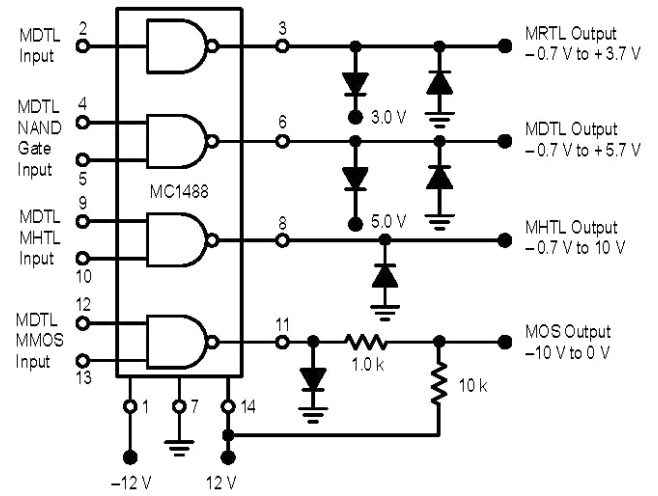
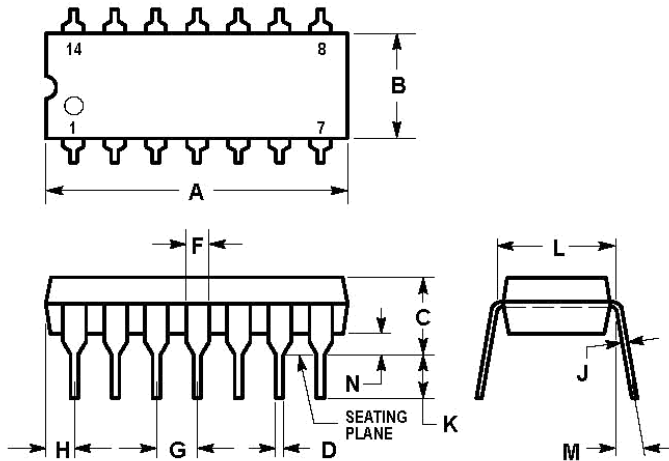

Figure 15. Logic Translator Applications



OUTLINE DIMENSIONS
P SUFFIX
PLASTIC PACKAGE
CASE 646-06
ISSUE L



NOTES:

- LEADS WITHIN 0.13 (0.005) RADIUS OF TRUE POSITION AT SEATING PLANE AT MAXIMUM MATERIAL CONDITION.
- DIMENSION L TO CENTER OF LEADS WHEN FORMED PARALLEL.
- DIMENSION B DOES NOT INCLUDE MOLD FLASH.
- ROUNDED CORNERS OPTIONAL.

DIM	INCHES		MILLIMETERS	
	MIN	MAX	MIN	MAX
A	0.715	0.770	18.16	19.56
B	0.240	0.280	6.10	6.60
C	0.145	0.185	3.69	4.69
D	0.015	0.021	0.38	0.53
F	0.040	0.070	1.02	1.78
G	0.100 BSC		2.54 BSC	
H	0.052	0.095	1.32	2.41
J	0.008	0.015	0.20	0.38
K	0.115	0.135	2.92	3.43
L	0.300 BSC		7.62 BSC	
M	0°	10°	0°	10°
N	0.015	0.039	0.39	1.01

D SUFFIX
PLASTIC PACKAGE
CASE 751A-03
(SO-14)
ISSUE F

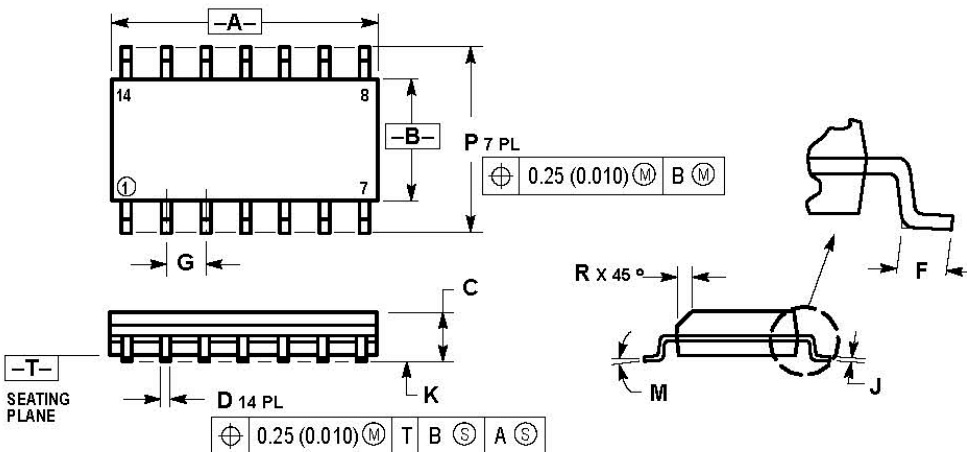

NOTES:

- DIMENSIONING AND TOLERANCING PER ANSI Y14.5M, 1982.
- CONTROLLING DIMENSION: MILLIMETER.
- DIMENSIONS A AND B DO NOT INCLUDE MOLD PROTRUSION.
- MAXIMUM MOLD PROTRUSION 0.15 (0.006) PER SIDE.
- DIMENSION D DOES NOT INCLUDE DAMBAR PROTRUSION. ALLOWABLE DAMBAR PROTRUSION SHALL BE 0.127 (0.005) TOTAL IN EXCESS OF THE D DIMENSION AT MAXIMUM MATERIAL CONDITION.

DIM	MILLIMETERS		INCHES	
	MIN	MAX	MIN	MAX
A	8.55	8.75	0.337	0.344
B	3.60	4.00	0.150	0.157
C	1.35	1.75	0.054	0.068
D	0.35	0.49	0.014	0.019
F	0.40	1.25	0.016	0.049
G	1.27 BSC		0.050 BSC	
J	0.19	0.25	0.008	0.009
K	0.10	0.25	0.004	0.009
M	0°	7°	0°	7°
P	5.60	6.20	0.228	0.244
R	0.25	0.50	0.010	0.019