

# MC3403, MC3303

## Single Supply Quad Operational Amplifiers

The MC3403 is a low cost, quad operational amplifier with true differential inputs. The device has electrical characteristics similar to the popular MC1741C. However, the MC3403 has several distinct advantages over standard operational amplifier types in single supply applications. The quad amplifier can operate at supply voltages as low as 3.0 V or as high as 36 V with quiescent currents about one third of those associated with the MC1741C (on a per amplifier basis). The common mode input range includes the negative supply, thereby eliminating the necessity for external biasing components in many applications. The output voltage range also includes the negative power supply voltage.

### Features

- Short Circuit Protected Outputs
- Class AB Output Stage for Minimal Crossover Distortion
- True Differential Input Stage
- Single Supply Operation: 3.0 V to 36 V
- Split Supply Operation:  $\pm 1.5$  V to  $\pm 18$  V
- Low Input Bias Currents: 500 nA Max
- Four Amplifiers Per Package
- Internally Compensated
- Similar Performance to Popular MC1741C
- Industry Standard Pin-outs
- ESD Diodes Added for Increased Ruggedness
- Pb-Free Packages are Available

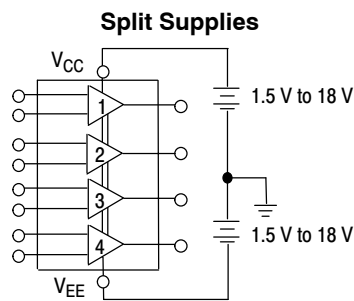
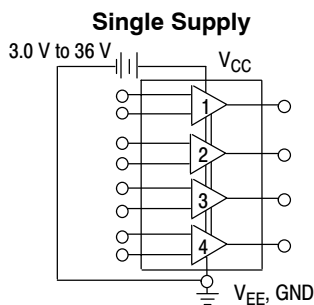

ON Semiconductor®

<http://onsemi.com>

### MARKING DIAGRAMS

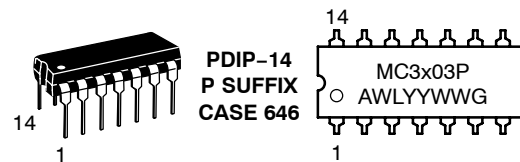
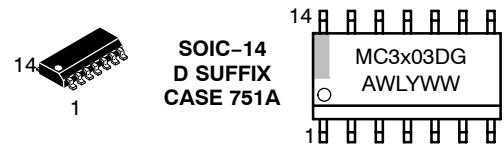

x = 3 or 4  
 A = Assembly Location  
 WL = Wafer Lot  
 YY, Y = Year  
 WW = Work Week  
 G = Pb-Free Package

### PIN CONNECTIONS

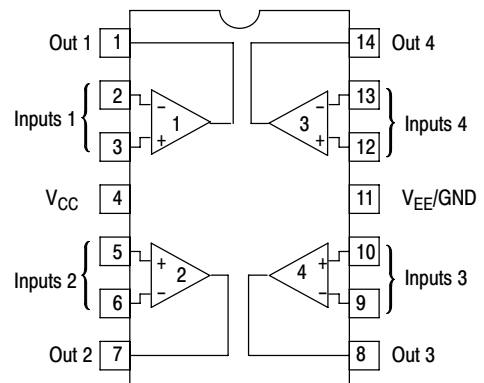

(Top View)

### ORDERING INFORMATION

See detailed ordering and shipping information in the package dimensions section on page 2 of this data sheet.

## MC3403, MC3303

### ORDERING INFORMATION

Device	Package	Shipping†
MC3303D	SOIC-14	55 Units / Rail
MC3303DG	SOIC-14 (Pb-Free)	
MC3303DR2	SOIC-14	2500 Tape & Reel
MC3303DR2G	SOIC-14 (Pb-Free)	
MC3303P	PDIP-14	25 Units / Rail
MC3303PG	PDIP-14 (Pb-Free)	
MC3403D	SOIC-14	55 Units / Rail
MC3403DG	SOIC-14 (Pb-Free)	
MC3403DR2	SOIC-14	2500 Tape & Reel
MC3403DR2G	SOIC-14 (Pb-Free)	
MC3403P	PDIP-14	25 Units / Rail
MC3403PG	PDIP-14 (Pb-Free)	

†For information on tape and reel specifications, including part orientation and tape sizes, please refer to our Tape and Reel Packaging Specifications Brochure, BRD8011/D.

### MAXIMUM RATINGS

Rating	Symbol	Value	Unit
Power Supply Voltages Single Supply Split Supplies	$V_{CC}$ $V_{CC}, V_{EE}$	36 $\pm 18$	Vdc
Input Differential Voltage Range (Note 1)	$V_{IDR}$	$\pm 36$	Vdc
Input Common Mode Voltage Range (Notes 1 and 2)	$V_{ICR}$	$\pm 18$	Vdc
Storage Temperature Range	$T_{stg}$	-55 to +125	°C
Operating Ambient Temperature Range	$T_A$	-40 to +85 0 to +70	°C
Junction Temperature	$T_J$	150	°C

Stresses exceeding Maximum Ratings may damage the device. Maximum Ratings are stress ratings only. Functional operation above the Recommended Operating Conditions is not implied. Extended exposure to stresses above the Recommended Operating Conditions may affect device reliability.

1. Split power supplies.
2. For supply voltages less than  $\pm 18$  V, the absolute maximum input voltage is equal to the supply voltage.

# MC3403, MC3303

## ELECTRICAL CHARACTERISTICS

( $V_{CC} = +15\text{ V}$ ,  $V_{EE} = -15\text{ V}$  for MC3403;  $V_{CC} = +14\text{ V}$ ,  $V_{EE} = \text{GND}$  for MC3303  $T_A = 25^\circ\text{C}$ , unless otherwise noted.)

Characteristic	Symbol	MC3403			MC3303			Unit
		Min	Typ	Max	Min	Typ	Max	
Input Offset Voltage $T_A = T_{\text{high}}$ to $T_{\text{low}}$ (Note 3)	$V_{IO}$	-	2.0	10	-	2.0	8.0	mV
		-	-	12	-	-	10	
Input Offset Current $T_A = T_{\text{high}}$ to $T_{\text{low}}$	$I_{IO}$	-	30	50	-	30	75	nA
		-	-	200	-	-	250	
Large Signal Open Loop Voltage Gain $V_O = \pm 10\text{ V}$ , $R_L = 2.0\text{ k}\Omega$ $T_A = T_{\text{high}}$ to $T_{\text{low}}$	$A_{VOL}$	20	200	-	20	200	-	V/mV
		15	-	-	15	-	-	
Input Bias Current $T_A = T_{\text{high}}$ to $T_{\text{low}}$	$I_{IB}$	-	-200	-500	-	-200	-500	nA
		-	-	-800	-	-	-1000	
Output Impedance $f = 20\text{ Hz}$	$z_o$	-	75	-	-	75	-	$\Omega$
Input Impedance $f = 20\text{ Hz}$	$z_i$	0.3	1.0	-	0.3	1.0	-	M $\Omega$
Output Voltage Range $R_L = 10\text{ k}\Omega$ $R_L = 2.0\text{ k}\Omega$ $R_L = 2.0\text{ k}\Omega$ , $T_A = T_{\text{high}}$ to $T_{\text{low}}$	$V_O$	$\pm 12$	$\pm 13.5$	-	12	12.5	-	V
		$\pm 10$	$\pm 13$	-	10	12	-	
		$\pm 10$	-	-	10	-	-	
Input Common Mode Voltage Range	$V_{ICR}$	+13 V - $V_{EE}$	+13 V - $V_{EE}$	-	+12 V - $V_{EE}$	+12.5 V - $V_{EE}$	-	V
Common Mode Rejection $R_S \leq 10\text{ k}\Omega$	CMR	70	90	-	70	90	-	dB
Power Supply Current ( $V_O = 0$ ) $R_L = \infty$	$I_{CC}$ , $I_{EE}$	-	2.8	7.0	-	2.8	7.0	mA
Individual Output Short-Circuit Current (Note 4)	$I_{SC}$	$\pm 10$	$\pm 20$	$\pm 45$	$\pm 10$	$\pm 30$	$\pm 45$	mA
Positive Power Supply Rejection Ratio	PSRR+	-	30	150	-	30	150	$\mu\text{V/V}$
Negative Power Supply Rejection Ratio	PSRR-	-	30	150	-	30	150	$\mu\text{V/V}$
Average Temperature Coefficient of Input Offset Current $T_A = T_{\text{high}}$ to $T_{\text{low}}$	$\Delta I_{IO}/\Delta T$	-	50	-	-	50	-	$\text{pA}/^\circ\text{C}$
Average Temperature Coefficient of Input Offset Voltage $T_A = T_{\text{high}}$ to $T_{\text{low}}$	$\Delta V_{IO}/\Delta T$	-	10	-	-	10	-	$\mu\text{V}/^\circ\text{C}$
Power Bandwidth $A_V = 1$ , $R_L = 10\text{ k}\Omega$ , $V_O = 20\text{ V(p-p)}$ , THD = 5%	BWp	-	9.0	-	-	9.0	-	kHz
Small-Signal Bandwidth $A_V = 1$ , $R_L = 10\text{ k}\Omega$ , $V_O = 50\text{ mV}$	BW	-	1.0	-	-	1.0	-	MHz
Slew Rate $A_V = 1$ , $V_i = -10\text{ V}$ to $+10\text{ V}$	SR	-	0.6	-	-	0.6	-	V/ $\mu\text{s}$
Rise Time $A_V = 1$ , $R_L = 10\text{ k}\Omega$ , $V_O = 50\text{ mV}$	$t_{TLH}$	-	0.35	-	-	0.35	-	$\mu\text{s}$
Fall Time $A_V = 1$ , $R_L = 10\text{ k}\Omega$ , $V_O = 50\text{ mV}$	$t_{TLH}$	-	0.35	-	-	0.35	-	$\mu\text{s}$
Overshoot $A_V = 1$ , $R_L = 10\text{ k}\Omega$ , $V_O = 50\text{ mV}$	os	-	20	-	-	20	-	%
Phase Margin $A_V = 1$ , $R_L = 2.0\text{ k}\Omega$ , $V_O = 200\text{ pF}$	$\phi_m$	-	60	-	-	60	-	$^\circ$
Crossover Distortion ( $V_{in} = 30\text{ mVpp}$ , $V_{out} = 2.0\text{ Vpp}$ , $f = 10\text{ kHz}$ )	-	-	1.0	-	-	1.0	-	%

3. MC3303:  $T_{\text{low}} = -40^\circ\text{C}$ ,  $T_{\text{high}} = +85^\circ\text{C}$ , MC3403:  $T_{\text{low}} = 0^\circ\text{C}$ ,  $T_{\text{high}} = +70^\circ\text{C}$

4. Not to exceed maximum package power dissipation.

# MC3403, MC3303

**ELECTRICAL CHARACTERISTICS** ( $V_{CC} = 5.0\text{ V}$ ,  $V_{EE} = \text{GND}$ ,  $T_A = 25^\circ\text{C}$ , unless otherwise noted.)

Characteristic	Symbol	MC3403			MC3303			Unit
		Min	Typ	Max	Min	Typ	Max	
Input Offset Voltage	$V_{IO}$	-	2.0	10	-	-	10	mV
Input Offset Current	$I_{IO}$	-	30	50	-	-	75	nA
Input Bias Current	$I_{IB}$	-	-200	-500	-	-	-500	nA
Large Signal Open Loop Voltage Gain $R_L = 2.0\text{ k}\Omega$	$A_{VOL}$	10	200	-	10	200	-	V/mV
Power Supply Rejection Ratio	PSRR	-	-	150	-	-	150	$\mu\text{V/V}$
Output Voltage Range (Note 5) $R_L = 10\text{ k}\Omega$ , $V_{CC} = 5.0\text{ V}$ $R_L = 10\text{ k}\Omega$ , $5.0 \leq V_{CC} \leq 30\text{ V}$	$V_{OR}$	3.3 $V_{CC}-2.0$	3.5 $V_{CC}-1.7$	- -	3.3 $V_{CC}-2.0$	3.5 $V_{CC}-1.7$	- -	$V_{pp}$
Power Supply Current	$I_{CC}$	-	2.5	7.0	-	2.5	7.0	mA
Channel Separation $f = 1.0\text{ kHz}$ to $20\text{ kHz}$ (Input Referenced)	CS	-	-120	-	-	-120	-	dB

5. Output will swing to ground with a  $10\text{ k}\Omega$  pull down resistor.

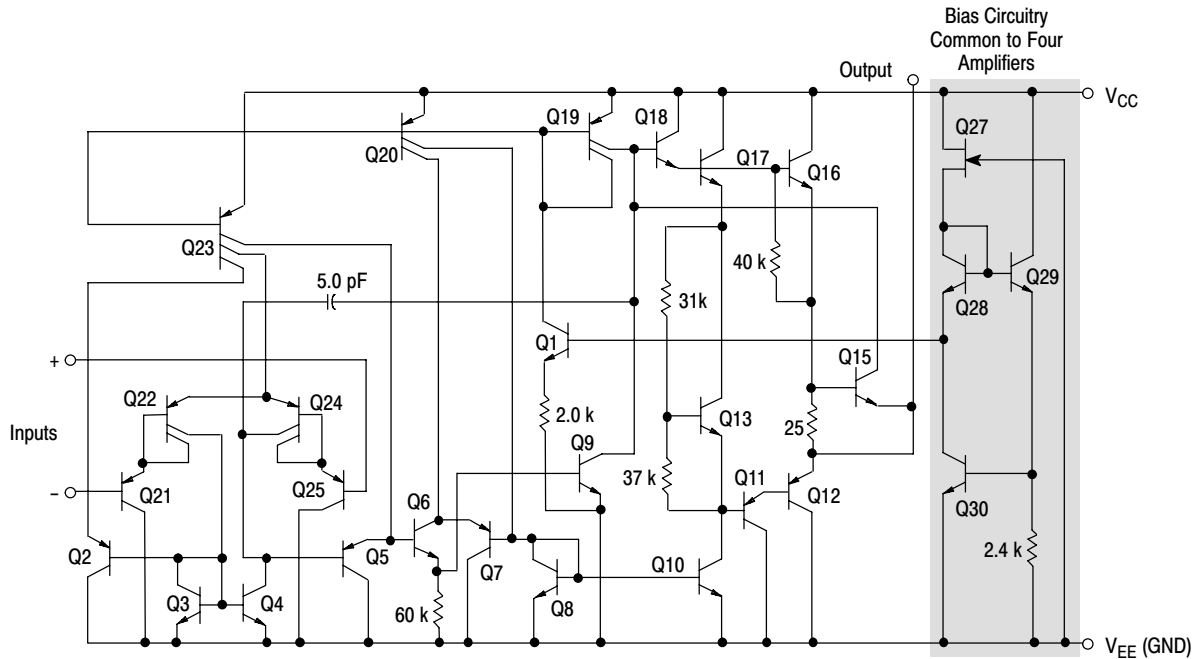

**Figure 1. Representative Schematic Diagram**  
(1/4 of Circuit Shown)

CIRCUIT DESCRIPTION

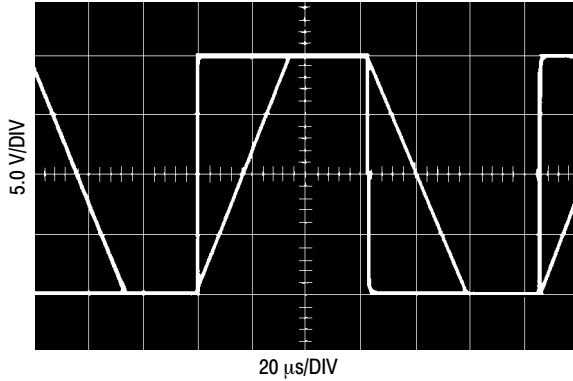

Figure 2. Inverter Pulse Response

The MC3403/3303 is made using four internally compensated, two-stage operational amplifiers. The first stage of each consists of differential input device Q24 and Q22 with input buffer transistors Q25 and Q21 and the differential to single ended converter Q3 and Q4. The first

stage performs not only the first stage gain function but also performs the level shifting and Transconductance reduction functions. By reducing the Transconductance, a smaller compensation capacitor (only 5.0 pF) can be employed, thus saving chip area. The Transconductance reduction is accomplished by splitting the collectors of Q24 and Q22. Another feature of this input stage is that the input common mode range can include the negative supply or ground, in single supply operation, without saturating either the input devices or the differential to single-ended converter. The second stage consists of a standard current source load amplifier stage.

The output stage is unique because it allows the output to swing to ground in single supply operation and yet does not exhibit any crossover distortion in split supply operation. This is possible because Class AB operation is utilized.

Each amplifier is biased from an internal voltage regulator which has a low temperature coefficient, thus giving each amplifier good temperature characteristics as well as excellent power supply rejection.

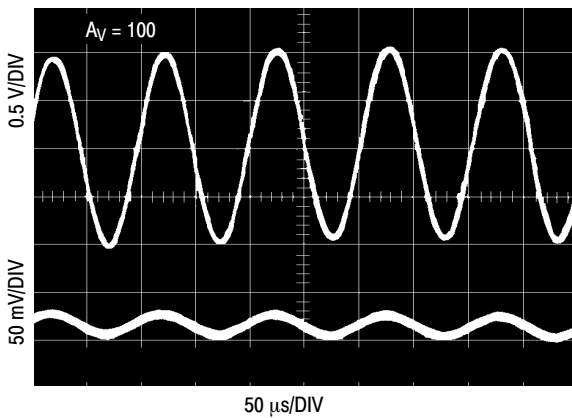

Figure 3. Sine Wave Response

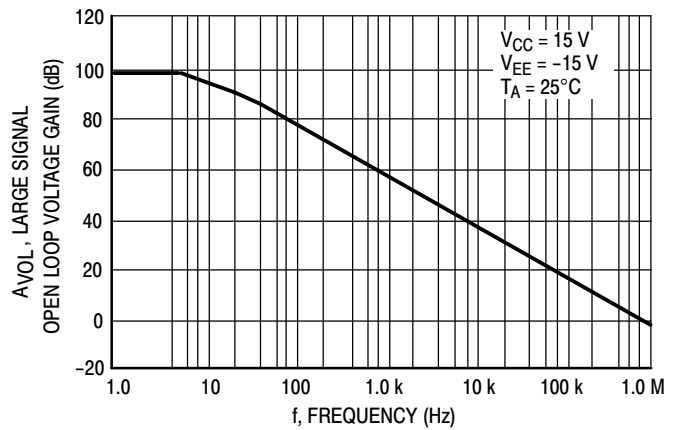

Figure 4. Open Loop Frequency Response

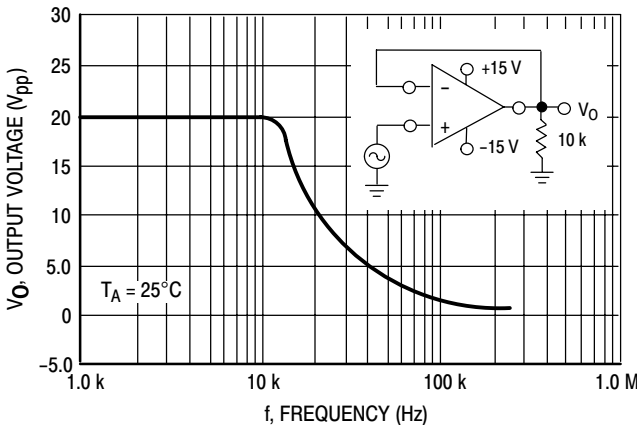

Figure 5. Power Bandwidth

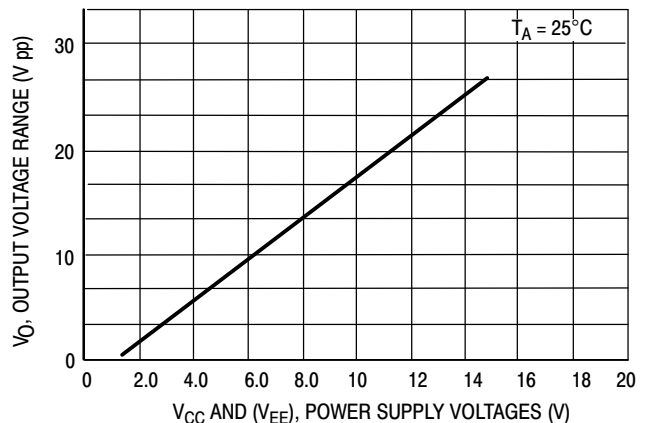
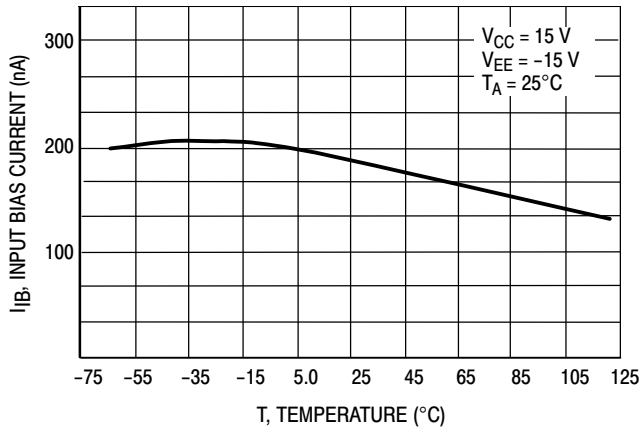
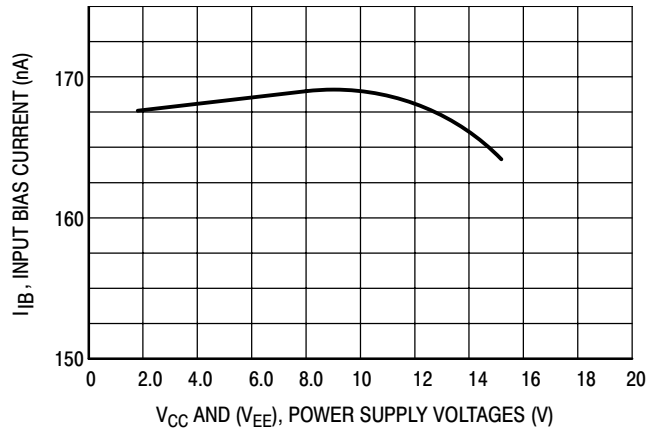

Figure 6. Output Swing versus Supply Voltage

# MC3403, MC3303



**Figure 7. Input Bias Current versus Temperature**



**Figure 8. Input Bias Current versus Supply Voltage**

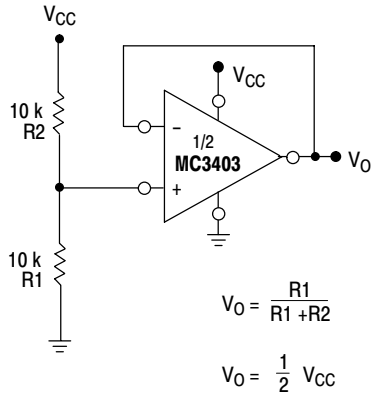

**Figure 9. Voltage Reference**

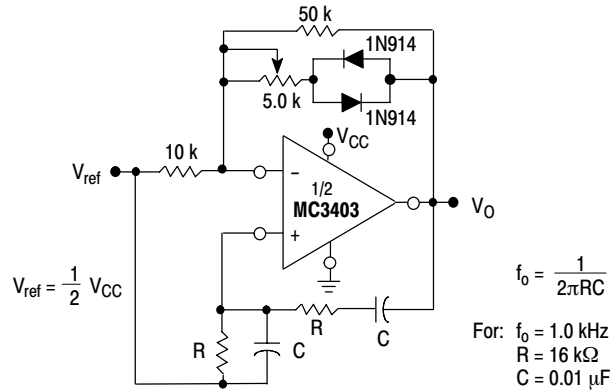

**Figure 10. Wien Bridge Oscillator**

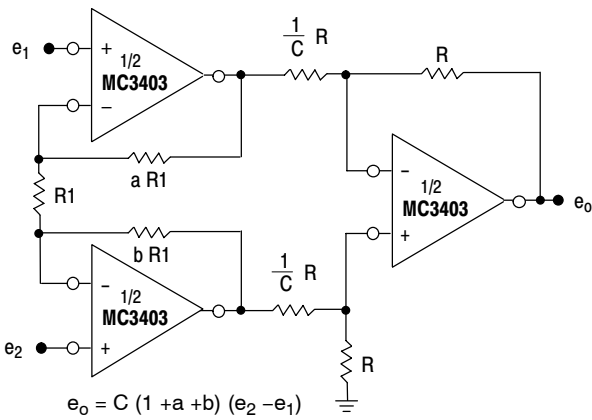

**Figure 11. High Impedance Differential Amplifier**

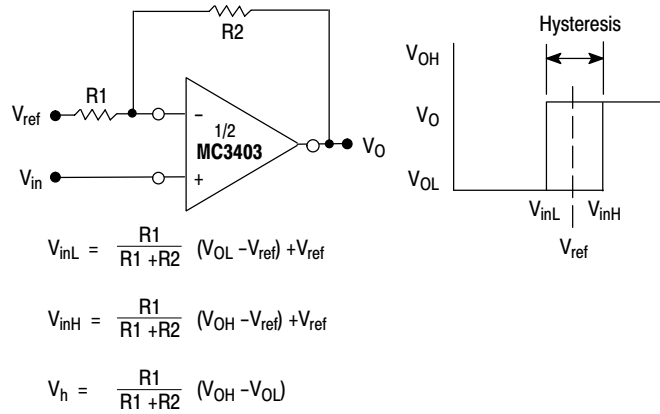

**Figure 12. Comparator with Hysteresis**

## MC3403, MC3303

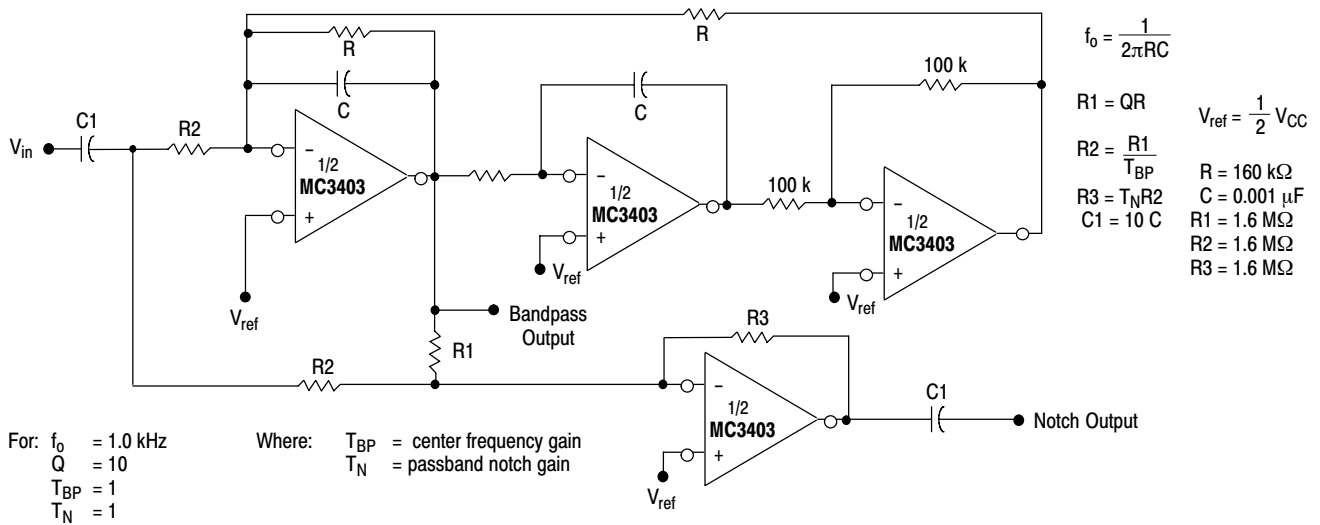

Figure 13. Bi-Quad Filter

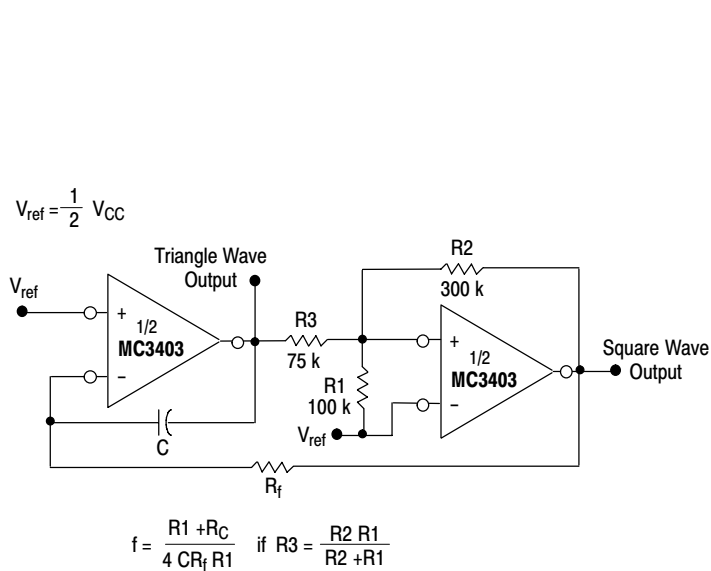
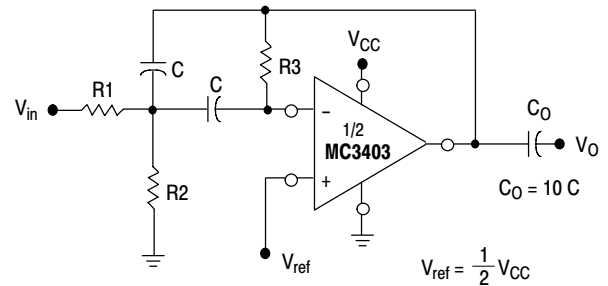

Figure 14. Function Generator



Given:  $f_0$  = center frequency  
 $A(f_0)$  = gain at center frequency

Choose value  $f_0, C$

$$\text{Then: } R3 = \frac{Q}{\pi f_0 C} \quad R1 = \frac{R3}{2 A(f_0)} \quad R2 = \frac{R1 R5}{4Q^2 R1 - R5}$$

For less than 10% error from operational amplifier  $\frac{O_o f_0}{BW} < 0.1$   
 where  $f_0$  and BW are expressed in Hz.

If source impedance varies, filter may be preceded with voltage follower buffer to stabilize filter parameters.

Figure 15. Multiple Feedback Bandpass Filter

# MC3403, MC3303

## PACKAGE DIMENSIONS

SOIC-14  
CASE 751A-03  
ISSUE H

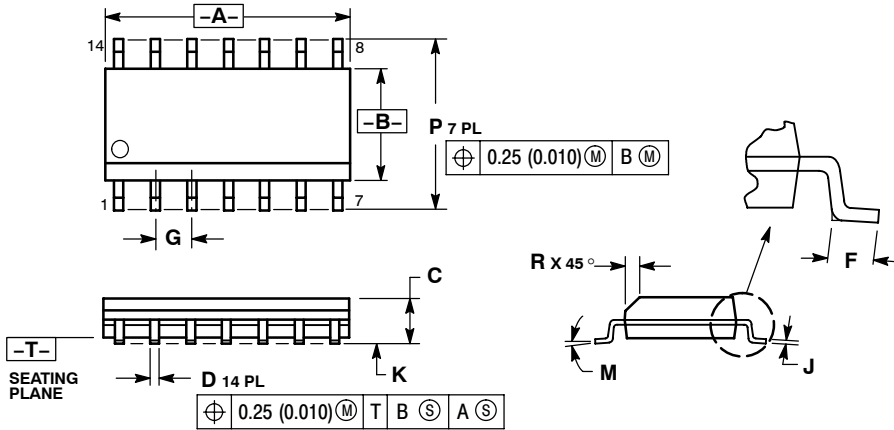

**NOTES:**

1. DIMENSIONING AND TOLERANCING PER ANSI Y14.5M, 1982.
2. CONTROLLING DIMENSION: MILLIMETER.
3. DIMENSIONS A AND B DO NOT INCLUDE MOLD PROTRUSION.
4. MAXIMUM MOLD PROTRUSION 0.15 (0.006) PER SIDE.
5. DIMENSION D DOES NOT INCLUDE DAMBAR PROTRUSION. ALLOWABLE DAMBAR PROTRUSION SHALL BE 0.127 (0.005) TOTAL IN EXCESS OF THE D DIMENSION AT MAXIMUM MATERIAL CONDITION.

DIM	MILLIMETERS		INCHES	
	MIN	MAX	MIN	MAX
A	8.55	8.75	0.337	0.344
B	3.80	4.00	0.150	0.157
C	1.35	1.75	0.054	0.068
D	0.35	0.49	0.014	0.019
F	0.40	1.25	0.016	0.049
G	1.27 BSC		0.050 BSC	
J	0.19	0.25	0.008	0.009
K	0.10	0.25	0.004	0.009
M	0°	7°	0°	7°
P	5.80	6.20	0.228	0.244
R	0.25	0.50	0.010	0.019

### SOLDERING FOOTPRINT\*

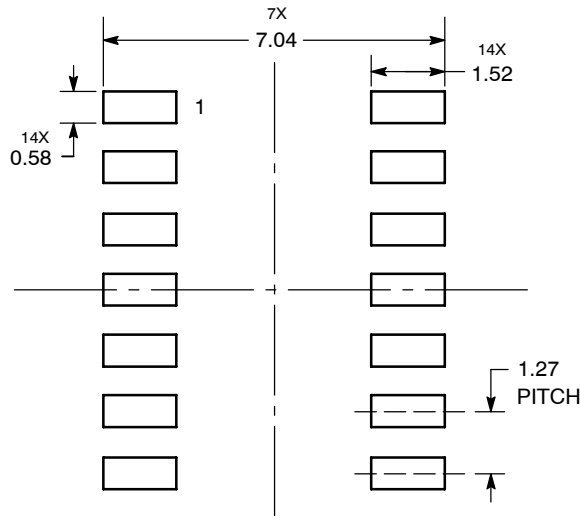

DIMENSIONS: MILLIMETERS

\*For additional information on our Pb-Free strategy and soldering details, please download the ON Semiconductor Soldering and Mounting Techniques Reference Manual, SOLDERRM/D.



# MC3403, MC3303

## PACKAGE DIMENSIONS

**PDIP-14**  
CASE 646-06  
ISSUE P

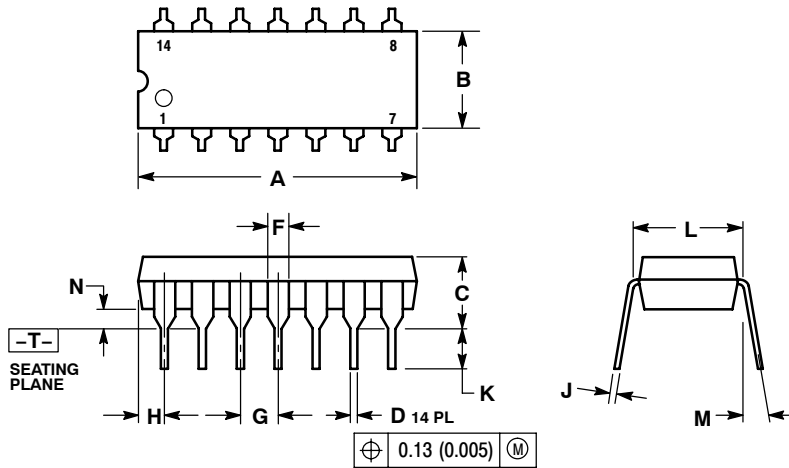

**NOTES:**

1. DIMENSIONING AND TOLERANCING PER ANSI Y14.5M, 1982.
2. CONTROLLING DIMENSION: INCH.
3. DIMENSION L TO CENTER OF LEADS WHEN FORMED PARALLEL.
4. DIMENSION B DOES NOT INCLUDE MOLD FLASH.
5. ROUNDED CORNERS OPTIONAL.

DIM	INCHES		MILLIMETERS	
	MIN	MAX	MIN	MAX
A	0.715	0.770	18.16	19.56
B	0.240	0.260	6.10	6.60
C	0.145	0.185	3.69	4.69
D	0.015	0.021	0.38	0.53
F	0.040	0.070	1.02	1.78
G	0.100 BSC		2.54 BSC	
H	0.052	0.095	1.32	2.41
J	0.008	0.015	0.20	0.38
K	0.115	0.135	2.92	3.43
L	0.290	0.310	7.37	7.87
M	---	10°	---	10°
N	0.015	0.039	0.38	1.01

**ON Semiconductor** and **ON** are registered trademarks of Semiconductor Components Industries, LLC (SCILLC). SCILLC reserves the right to make changes without further notice to any products herein. SCILLC makes no warranty, representation or guarantee regarding the suitability of its products for any particular purpose, nor does SCILLC assume any liability arising out of the application or use of any product or circuit, and specifically disclaims any and all liability, including without limitation special, consequential or incidental damages. "Typical" parameters which may be provided in SCILLC data sheets and/or specifications can and do vary in different applications and actual performance may vary over time. All operating parameters, including "Typicals" must be validated for each customer application by customer's technical experts. SCILLC does not convey any license under its patent rights nor the rights of others. SCILLC products are not designed, intended, or authorized for use as components in systems intended for surgical implant into the body, or other applications intended to support or sustain life, or for any other application in which the failure of the SCILLC product could create a situation where personal injury or death may occur. Should Buyer purchase or use SCILLC products for any such unintended or unauthorized application, Buyer shall indemnify and hold SCILLC and its officers, employees, subsidiaries, affiliates, and distributors harmless against all claims, costs, damages, and expenses, and reasonable attorney fees arising out of, directly or indirectly, any claim of personal injury or death associated with such unintended or unauthorized use, even if such claim alleges that SCILLC was negligent regarding the design or manufacture of the part. SCILLC is an Equal Opportunity/Affirmative Action Employer. This literature is subject to all applicable copyright laws and is not for resale in any manner.

### PUBLICATION ORDERING INFORMATION

**LITERATURE FULFILLMENT:**  
Literature Distribution Center for ON Semiconductor  
P.O. Box 5163, Denver, Colorado 80217 USA  
**Phone:** 303-675-2175 or 800-344-3860 Toll Free USA/Canada  
**Fax:** 303-675-2176 or 800-344-3867 Toll Free USA/Canada  
**Email:** orderlit@onsemi.com

**N. American Technical Support:** 800-282-9855 Toll Free  
USA/Canada  
**Europe, Middle East and Africa Technical Support:**  
Phone: 421 33 790 2910  
**Japan Customer Focus Center**  
Phone: 81-3-5773-3850

**ON Semiconductor Website:** [www.onsemi.com](http://www.onsemi.com)  
**Order Literature:** <http://www.onsemi.com/orderlit>

For additional information, please contact your local Sales Representative