

MC34060A, MC33060A

Fixed Frequency, PWM, Voltage Mode Single Ended Controllers

The MC34060A is a low cost fixed frequency, pulse width modulation control circuit designed primarily for single-ended SWITCHMODE™ power supply control.

The MC34060A is specified over the commercial operating temperature range of 0° to +70°C, and the MC33060A is specified over an automotive temperature range of -40° to +85°C.

Features

- Complete Pulse Width Modulation Control Circuitry
- On-Chip Oscillator with Master or Slave Operation
- On-Chip Error Amplifiers
- On-Chip 5.0 V Reference, 1.5% Accuracy
- Adjustable Dead-Time Control
- Uncommitted Output Transistor Rated to 200 mA Source or Sink
- Undervoltage Lockout
- These are Pb-Free and Halide-Free Devices

PIN CONNECTIONS

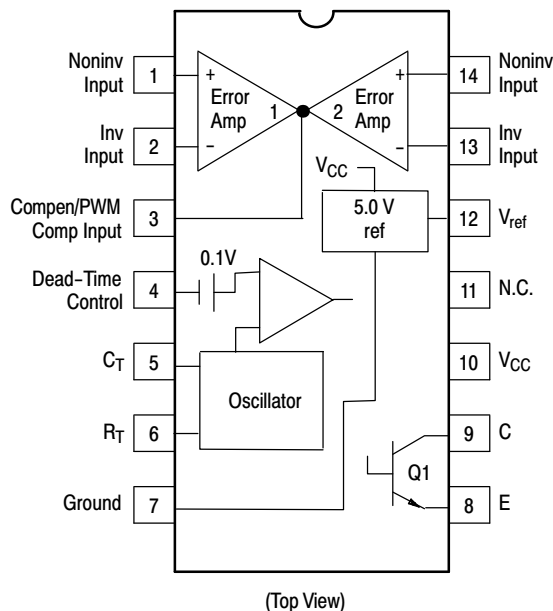

ON Semiconductor®

<http://onsemi.com>

MARKING DIAGRAMS

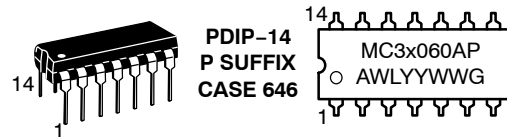
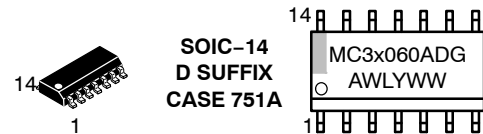

- x = 3 or 4
- A = Assembly Location
- WL = Wafer Lot
- Y, YY = Year
- WW = Work Week
- G = Pb-Free Package

ORDERING INFORMATION

See detailed ordering and shipping information in the package dimensions section on page 14 of this data sheet.

MC34060A, MC33060A

MAXIMUM RATINGS (Full operating ambient temperature range applies, unless otherwise noted.)

Rating	Symbol	Value	Unit
Power Supply Voltage	V_{CC}	42	V
Collector Output Voltage	V_C	42	V
Collector Output Current (Note 3)	I_C	500	mA
Amplifier Input Voltage Range	V_{in}	-0.3 to +42	V
Power Dissipation @ $T_A \leq 45^\circ\text{C}$	P_D	1000	mW
Operating Junction Temperature	T_J	125	$^\circ\text{C}$
Storage Temperature Range	T_{stg}	-55 to +125	$^\circ\text{C}$
Operating Ambient Temperature Range For MC34060A For MC33060A	T_A	0 to +70 -40 to +85	$^\circ\text{C}$
ESD Capability Machine Model Human Body Model		200 2.0	V kV

Stresses exceeding Maximum Ratings may damage the device. Maximum Ratings are stress ratings only. Functional operation above the Recommended Operating Conditions is not implied. Extended exposure to stresses above the Recommended Operating Conditions may affect device reliability.

- This device series contains ESD protection and exceeds the following tests:
Pins 1– 14: Human Body Model 2000 V per JEDEC Standard JESD22–A114E.
Machine Model Method 200 V per JEDEC Standard JESD22–A115–A.
- This device contains Latch–Up protection and exceeds ± 100 mA per JEDEC Standard JESD78.

THERMAL CHARACTERISTICS

Characteristics	Symbol	P Suffix Package	D Suffix Package	Unit
Thermal Resistance, Junction–to–Ambient	$R_{\theta JA}$	80	120	$^\circ\text{C}/\text{W}$
Derating Ambient Temperature	T_A	45	45	$^\circ\text{C}$

RECOMMENDED OPERATING CONDITIONS

Condition/Value	Symbol	Min	Typ	Max	Unit
Power Supply Voltage	V_{CC}	7.0	15	40	V
Collector Output Voltage	V_C	–	30	40	V
Collector Output Current	I_C	–	–	200	mA
Amplifier Input Voltage	V_{in}	-0.3	–	$V_{CC} - 2$	V
Current Into Feedback Terminal	I_{fb}	–	–	0.3	mA
Reference Output Current	I_{ref}	–	–	10	mA
Timing Resistor	R_T	1.8	47	500	$k\Omega$
Timing Capacitor	C_T	0.00047	0.001	10	μF
Oscillator Frequency	f_{osc}	1.0	25	200	kHz
PWM Input Voltage (Pins 3 and 4)	–	-0.3	–	5.3	V

- Maximum thermal limits must be observed.

MC34060A, MC33060A

ELECTRICAL CHARACTERISTICS ($V_{CC} = 15\text{ V}$, $C_T = 0.01\ \mu\text{F}$, $R_T = 12\ \text{k}\Omega$, unless otherwise noted. For typical values $T_A = 25^\circ\text{C}$, for min/max values T_A is the operating ambient temperature range that applies, unless otherwise noted.)

Characteristics	Symbol	Min	Typ	Max	Unit
-----------------	--------	-----	-----	-----	------

REFERENCE SECTION

Reference Voltage ($I_O = 1.0\ \text{mA}$, $T_A = 25^\circ\text{C}$) $T_A = T_{\text{low}}$ to T_{high} – MC34060A – MC33060A	V_{ref}	4.925 4.9 4.85	5.0 – –	5.075 5.1 5.1	V
Line Regulation ($V_{CC} = 7.0\ \text{V}$ to $40\ \text{V}$, $I_O = 10\ \text{mA}$)	Reg_{line}	–	2.0	25	mV
Load Regulation ($I_O = 1.0\ \text{mA}$ to $10\ \text{mA}$)	Reg_{load}	–	2.0	15	mV
Short Circuit Output Current ($V_{\text{ref}} = 0\ \text{V}$)	I_{SC}	15	35	75	mA

OUTPUT SECTION

Collector Off-State Current ($V_{CC} = 40\ \text{V}$, $V_{CE} = 40\ \text{V}$)	$I_{C(\text{off})}$	–	2.0	100	μA
Emitter Off-State Current ($V_{CC} = 40\ \text{V}$, $V_{CE} = 40\ \text{V}$, $V_E = 0\ \text{V}$)	$I_{E(\text{off})}$	–	–	–100	μA
Collector-Emitter Saturation Voltage (Note 4) Common-Emitter ($V_E = 0\ \text{V}$, $I_C = 200\ \text{mA}$) Emitter-Follower ($V_C = 15\ \text{V}$, $I_E = -200\ \text{mA}$)	$V_{\text{sat}(C)}$ $V_{\text{sat}(E)}$	– –	1.1 1.5	1.5 2.5	V
Output Voltage Rise Time ($T_A = 25^\circ\text{C}$) Common-Emitter (See Figure 12) Emitter-Follower (See Figure 13)	t_r	– –	100 100	200 200	ns
Output Voltage Fall Time ($T_A = 25^\circ\text{C}$) Common-Emitter (See Figure 12) Emitter-Follower (See Figure 13)	t_r	– –	40 40	100 100	ns

ERROR AMPLIFIER SECTION

Input Offset Voltage ($V_{O[\text{Pin } 3]} = 2.5\ \text{V}$)	V_{IO}	–	2.0	10	mV
Input Offset Current ($V_{C[\text{Pin } 3]} = 2.5\ \text{V}$)	I_{IO}	–	5.0	250	nA
Input Bias Current ($V_{O[\text{Pin } 3]} = 2.5\ \text{V}$)	I_{IB}	–	–0.1	–2.0	μA
Input Common Mode Voltage Range ($V_{CC} = 40\ \text{V}$)	V_{ICR}	0 to $V_{CC} - 2.0$	–	–	V
Inverting Input Voltage Range	$V_{\text{IR(INV)}}$	–0.3 to $V_{CC} - 2.0$	–	–	V
Open-Loop Voltage Gain ($\Delta V_O = 3.0\ \text{V}$, $V_O = 0.5\ \text{V}$ to $3.5\ \text{V}$, $R_L = 2.0\ \text{k}\Omega$)	A_{VOL}	70	95	–	dB
Unity-Gain Crossover Frequency ($V_O = 0.5\ \text{V}$ to $3.5\ \text{V}$, $R_L = 2.0\ \text{k}\Omega$)	f_c	–	600	–	kHz
Phase Margin at Unity-Gain ($V_O = 0.5\ \text{V}$ to $3.5\ \text{V}$, $R_L = 2.0\ \text{k}\Omega$)	ϕ_m	–	65	–	deg.
Common Mode Rejection Ratio ($V_{CC} = 40\ \text{V}$, $V_{\text{in}} = 0\ \text{V}$ to $38\ \text{V}$)	CMRR	65	90	–	dB
Power Supply Rejection Ratio ($\Delta V_{CC} = 33\ \text{V}$, $V_O = 2.5\ \text{V}$, $R_L = 2.0\ \text{k}\Omega$)	PSRR	–	100	–	dB
Output Sink Current ($V_{O[\text{Pin } 3]} = 0.7\ \text{V}$)	I_{O-}	0.3	0.7	–	mA
Output Source Current ($V_{O[\text{Pin } 3]} = 3.5\ \text{V}$)	I_{O+}	–2.0	–4.0	–	mA

4. Low duty cycle techniques are used during test to maintain junction temperature as close to ambient temperatures as possible.

$T_{\text{low}} = -40^\circ\text{C}$ for MC33060A
= 0°C for MC34060A

$T_{\text{high}} = +85^\circ\text{C}$ for MC33060A
= $+70^\circ\text{C}$ for MC34060A

MC34060A, MC33060A

ELECTRICAL CHARACTERISTICS (continued) ($V_{CC} = 15\text{ V}$, $C_T = 0.01\ \mu\text{F}$, $R_T = 12\ \text{k}\Omega$, unless otherwise noted.)

For typical values $T_A = 25^\circ\text{C}$, for min/max values T_A is the operating ambient temperature range that applies, unless otherwise noted.)

Characteristics	Symbol	Min	Typ	Max	Unit
-----------------	--------	-----	-----	-----	------

PWM COMPARATOR SECTION (Test circuit Figure 11)

Input Threshold Voltage (Zero Duty Cycle)	V_{TH}	–	3.5	4.5	V
Input Sink Current ($V_{[Pin\ 3]} = 0.7\ \text{V}$)	I_I	0.3	0.7	–	mA

DEAD-TIME CONTROL SECTION (Test circuit Figure 11)

Input Bias Current (Pin 4) ($V_{in} = 0\ \text{V}$ to $5.25\ \text{V}$)	$I_{IB(DT)}$	–	–1.0	–10	μA
Maximum Output Duty Cycle ($V_{in} = 0\ \text{V}$, $C_T = 0.01\ \mu\text{F}$, $R_T = 12\ \text{k}\Omega$) ($V_{in} = 0\ \text{V}$, $C_T = 0.001\ \mu\text{F}$, $R_T = 47\ \text{k}\Omega$)	DC_{max}	90 –	96 92	100 –	%
Input Threshold Voltage (Pin 4) (Zero Duty Cycle) (Maximum Duty Cycle)	V_{TH}	– 0	2.8 –	3.3 –	V

OSCILLATOR SECTION

Frequency ($C_T = 0.01\ \mu\text{F}$, $R_T = 12\ \text{k}\Omega$, $T_A = 25^\circ\text{C}$) $T_A = T_{low}$ to T_{high} – MC34060A – MC33060A ($C_T = 0.001\ \mu\text{F}$, $R_T = 47\ \text{k}\Omega$)	f_{osc}	9.7 9.5 9.0 –	10.5 – – 25	11.3 11.5 11.5 –	kHz
Standard Deviation of Frequency* ($C_T = 0.001\ \mu\text{F}$, $R_T = 47\ \text{k}\Omega$)	$\sigma_{f_{osc}}$	–	1.5	–	%
Frequency Change with Voltage ($V_{CC} = 7.0\ \text{V}$ to $40\ \text{V}$)	$\Delta f_{osc}(\Delta V)$	–	0.5	2.0	%
Frequency Change with Temperature ($\Delta T_A = T_{low}$ to T_{high}) ($C_T = 0.01\ \mu\text{F}$, $R_T = 12\ \text{k}\Omega$)	$\Delta f_{osc}(\Delta T)$	– –	4.0 –	– –	%

UNDERVOLTAGE LOCKOUT SECTION

Turn-On Threshold (V_{CC} increasing, $I_{ref} = 1.0\ \text{mA}$)	V_{th}	4.0	4.7	5.5	V
Hysteresis	V_H	50	150	300	mV

TOTAL DEVICE

Standby Supply Current (Pin 6 at V_{ref} , all other inputs and outputs open) ($V_{CC} = 15\ \text{V}$) ($V_{CC} = 40\ \text{V}$)	I_{CC}	– –	5.5 7.0	10 15	mA
Average Supply Current ($V_{[Pin\ 4]} = 2.0\ \text{V}$, $C_T = 0.001\ \mu\text{F}$, $R_T = 47\ \text{k}\Omega$). See Figure 11.	I_S	–	7.0	–	mA

*Standard deviation is a measure of the statistical distribution about the mean as derived from the formula; $\sigma = \sqrt{\frac{\sum_{n=1}^N (x_n - \bar{x})^2}{N-1}}$

MC34060A, MC33060A

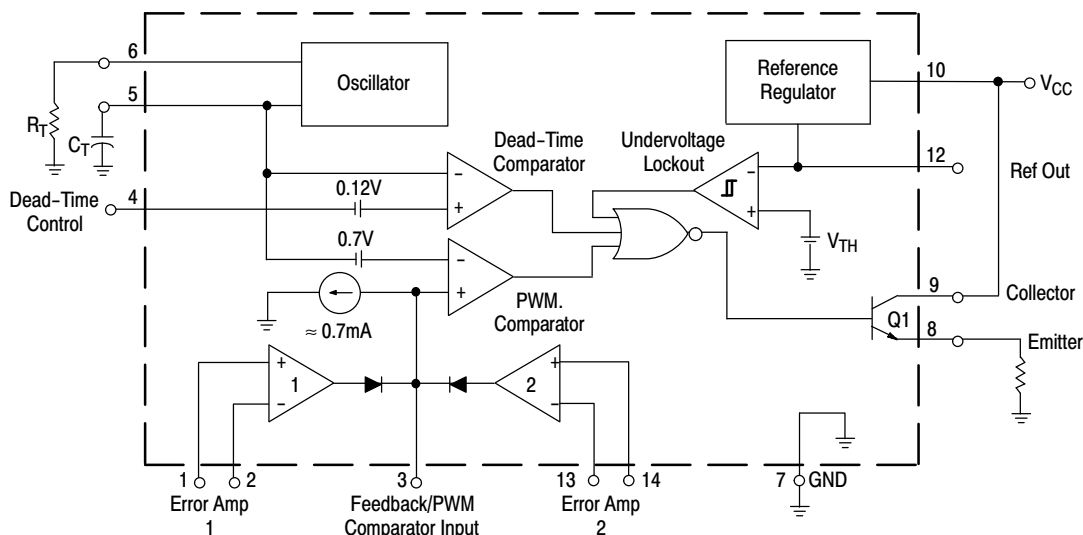

This device contains 46 active transistors.

Figure 1. Block Diagram

Description

The MC34060A is a fixed-frequency pulse width modulation control circuit, incorporating the primary building blocks required for the control of a switching power supply (see Figure 1). An internal-linear sawtooth oscillator is frequency-programmable by two external components, R_T and C_T . The approximate oscillator frequency is determined by:

$$f_{osc} \cong \frac{1.2}{R_T \cdot C_T}$$

For more information refer to Figure 3.

Output pulse width modulation is accomplished by comparison of the positive sawtooth waveform across capacitor C_T to either of two control signals. The output is enabled only during that portion of time when the sawtooth voltage is greater than the control signals. Therefore, an increase in control-signal amplitude causes a corresponding linear decrease of output pulse width. (Refer to the Timing Diagram shown in Figure 2.)

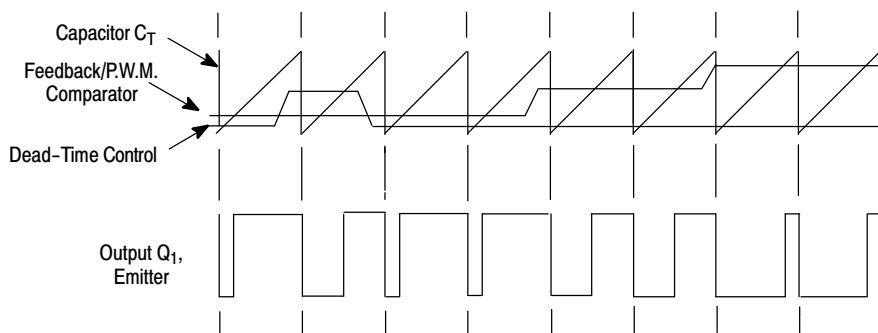

Figure 2. Timing Diagram

APPLICATIONS INFORMATION

The control signals are external inputs that can be fed into the dead-time control, the error amplifier inputs, or the feed-back input. The dead-time control comparator has an effective 120 mV input offset which limits the minimum output dead time to approximately the first 4% of the sawtooth-cycle time. This would result in a maximum duty cycle of 96%. Additional dead time may be imposed on the output by setting the dead time-control input to a fixed voltage, ranging between 0 V to 3.3 V.

The pulse width modulator comparator provides a means for the error amplifiers to adjust the output pulse width from the maximum percent on-time, established by the dead time control input, down to zero, as the voltage at the feedback

pin varies from 0.5 V to 3.5 V. Both error amplifiers have a common mode input range from -0.3 V to ($V_{CC} - 2.0$ V), and may be used to sense power supply output voltage and current. The error-amplifier outputs are active high and are ORed together at the noninverting input of the pulse-width modulator comparator. With this configuration, the amplifier that demands minimum output on time, dominates control of the loop.

The MC34060A has an internal 5.0 V reference capable of sourcing up to 10 mA of load currents for external bias circuits. The reference has an internal accuracy of $\pm 5\%$ with a typical thermal drift of less than 50 mV over an operating temperature range of 0° to +70°C.

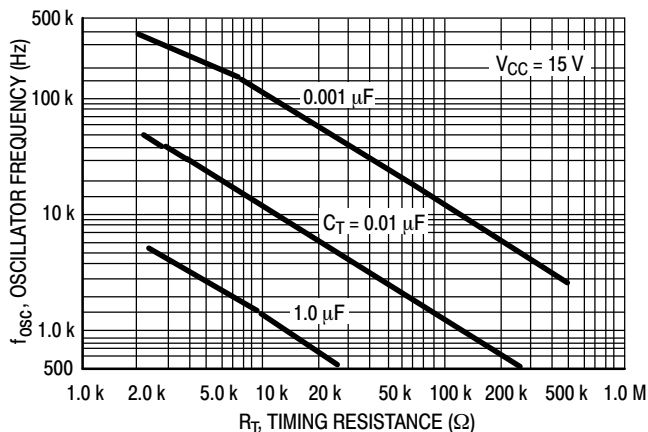

Figure 3. Oscillator Frequency versus Timing Resistance

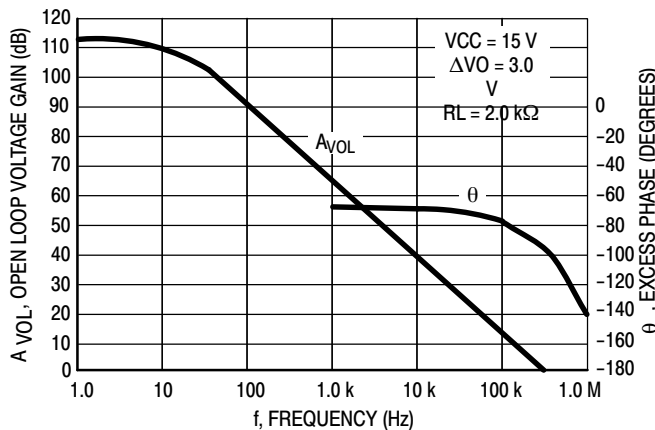

Figure 4. Open Loop Voltage Gain and Phase versus Frequency

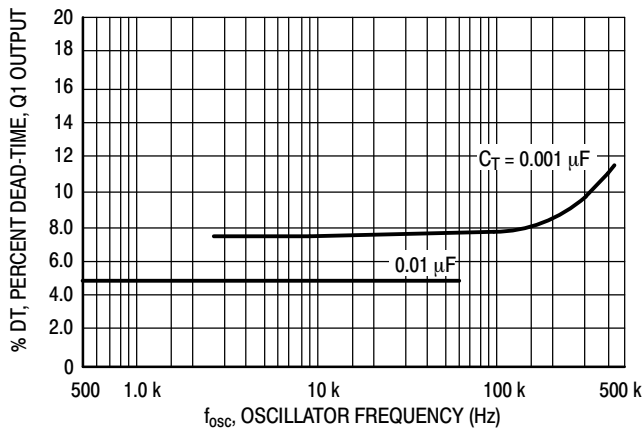

Figure 5. Percent Deadtime versus Oscillator Frequency

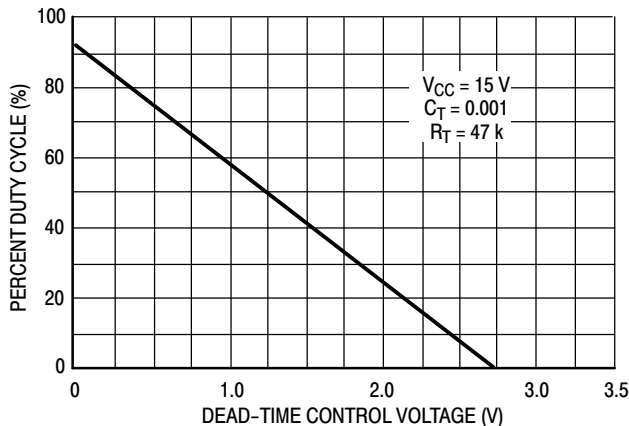

Figure 6. Percent Duty Cycle versus Dead-Time Control Voltage

MC34060A, MC33060A

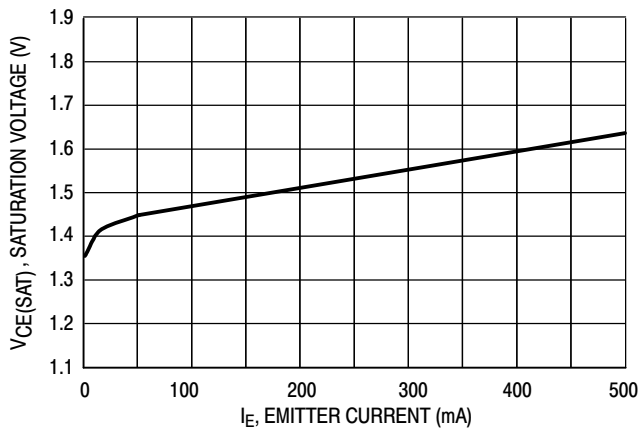

Figure 7. Emitter-Follower Configuration Output Saturation Voltage versus Emitter Current

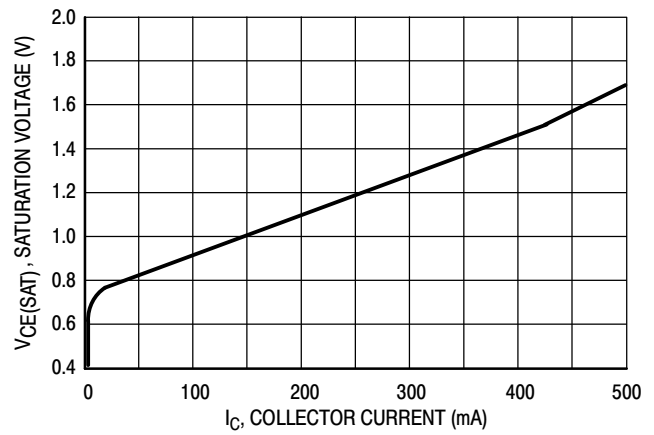

Figure 8. Common-Emitter Configuration Output Saturation Voltage versus Collector Current

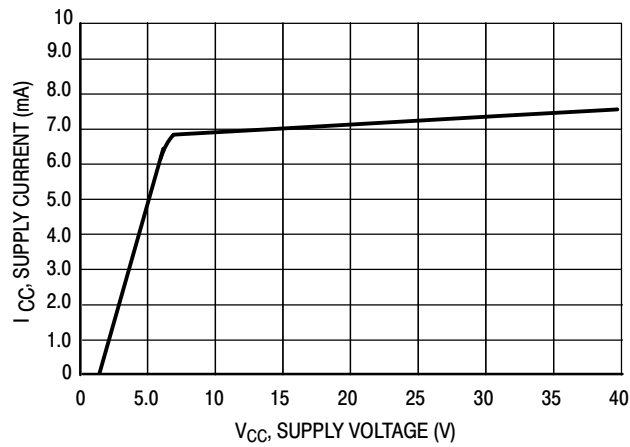

Figure 9. Standby Supply Current versus Supply Voltage

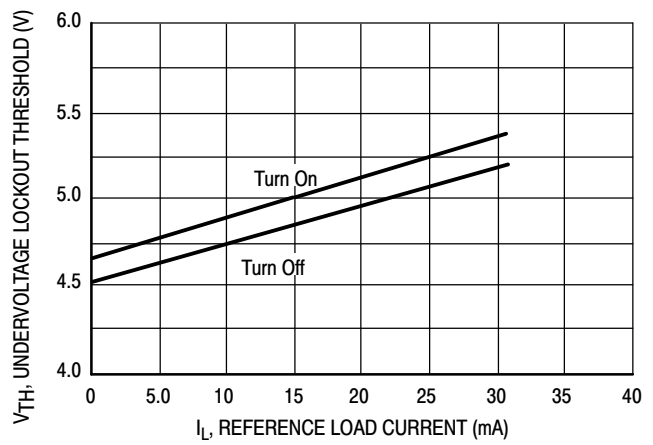

Figure 10. Undervoltage Lockout Thresholds versus Reference Load Current

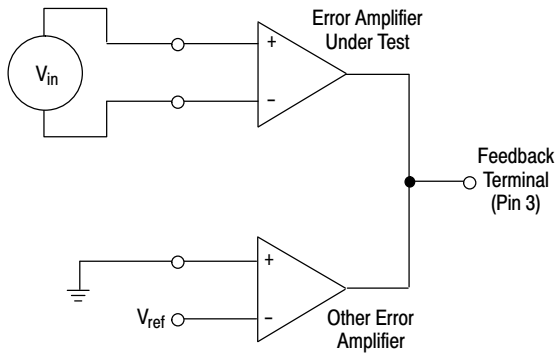

Figure 11. Error Amplifier Characteristics

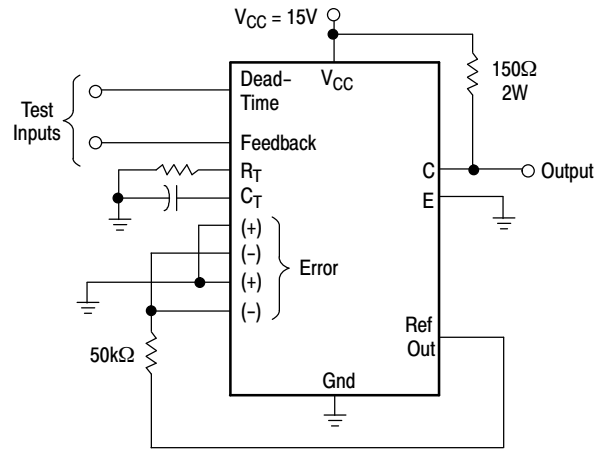

Figure 12. Deadtime and Feedback Control

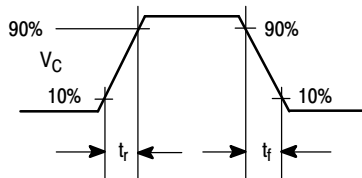
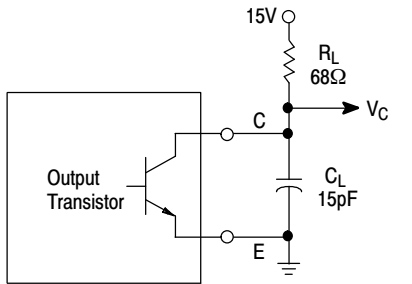

Figure 13. Common-Emitter Configuration and Waveform

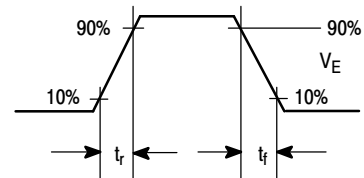
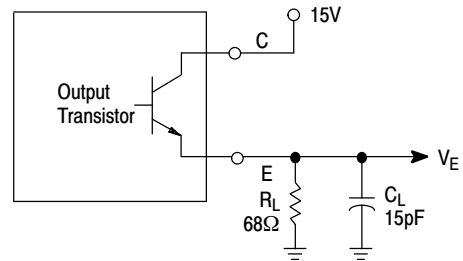

Figure 14. Emitter-Follower Configuration and Waveform

MC34060A, MC33060A

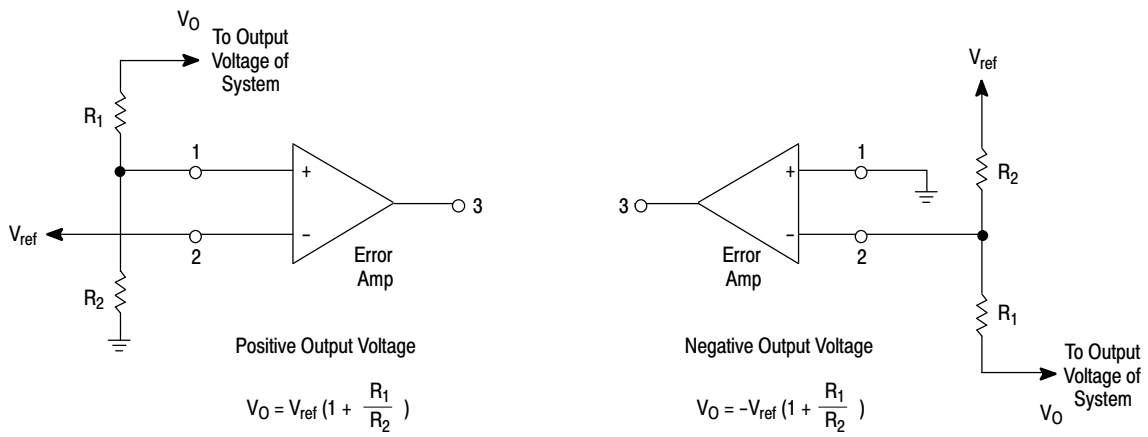

Figure 15. Error Amplifier Sensing Techniques

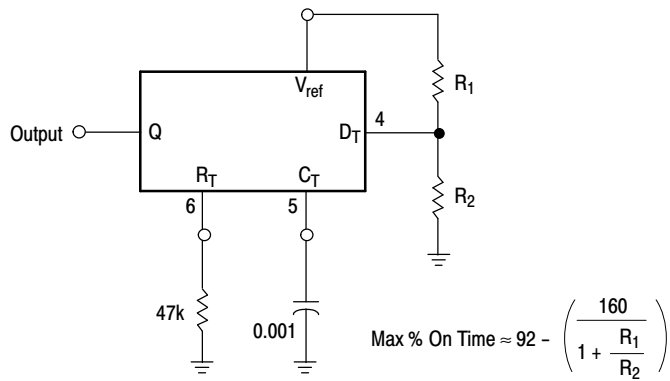

Figure 16. Deadtime Control Circuit

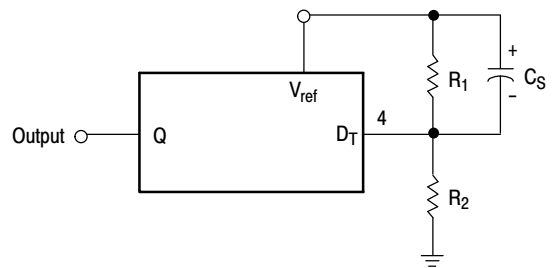

Figure 17. Soft-Start Circuit

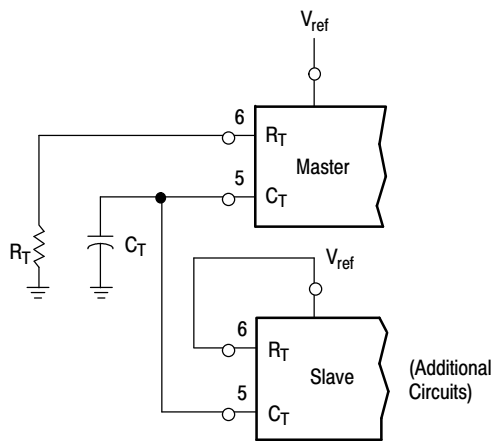
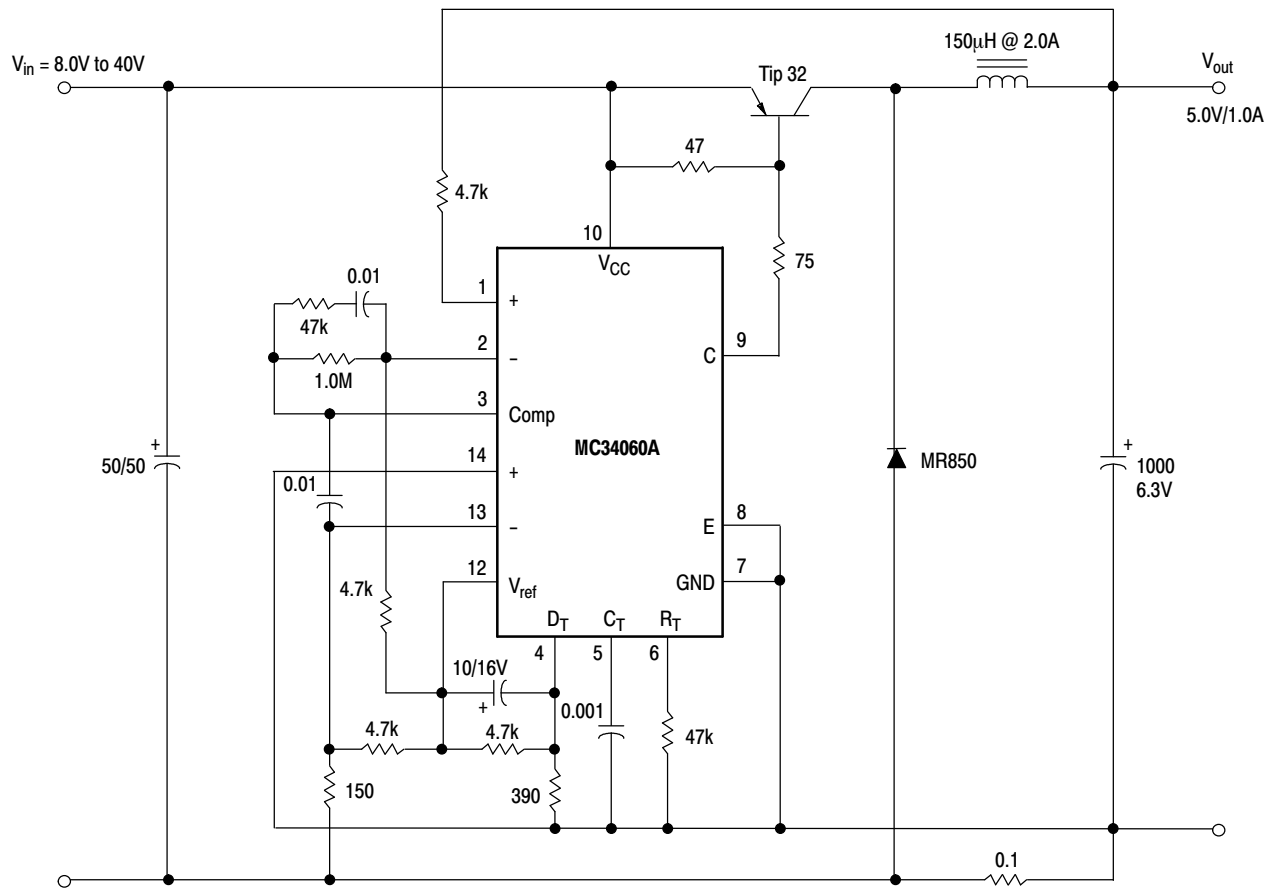

Figure 18. Slaving Two or More Control Circuits

MC34060A, MC33060A



Test	Conditions	Results
Line Regulation	$V_{in} = 8.0 \text{ V to } 40 \text{ V}$, $I_O = 1.0 \text{ A}$	25 mV 0.5%
Load Regulation	$V_{in} = 12 \text{ V}$, $I_O = 1.0 \text{ mA to } 1.0 \text{ A}$	3.0 mV 0.06%
Output Ripple	$V_{in} = 12 \text{ V}$, $I_O = 1.0 \text{ A}$	75 mV p-p P.A.R.D.
Short Circuit Current	$V_{in} = 12 \text{ V}$, $R_L = 0.1 \Omega$	1.6 A
Efficiency	$V_{in} = 12 \text{ V}$, $I_O = 1.0 \text{ A}$	73%

Figure 19. Step-Down Converter with Soft-Start and Output Current Limiting

MC34060A, MC33060A

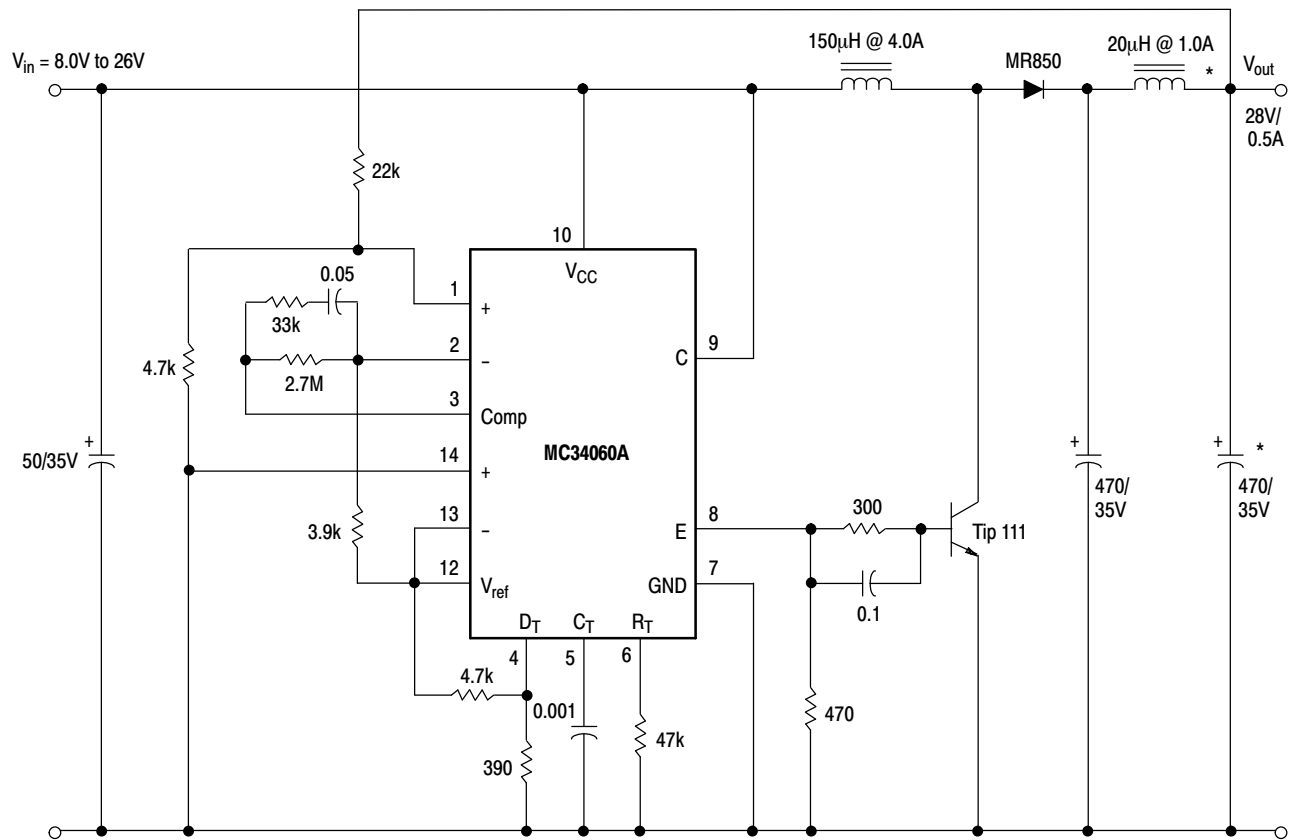

Test	Conditions	Results
Line Regulation	$V_{in} = 8.0 \text{ V to } 26 \text{ V}, I_O = 0.5 \text{ A}$	40 mV 0.14%
Load Regulation	$V_{in} = 12 \text{ V}, I_O = 1.0 \text{ mA to } 0.5 \text{ A}$	5.0 mV 0.18%
Output Ripple	$V_{in} = 12 \text{ V}, I_O = 0.5 \text{ A}$	24 mV p-p P.A.R.D.
Efficiency	$V_{in} = 12 \text{ V}, I_O = 0.5 \text{ A}$	75%

*Optional circuit to minimize output ripple

Figure 20. Step-Up Converter

MC34060A, MC33060A

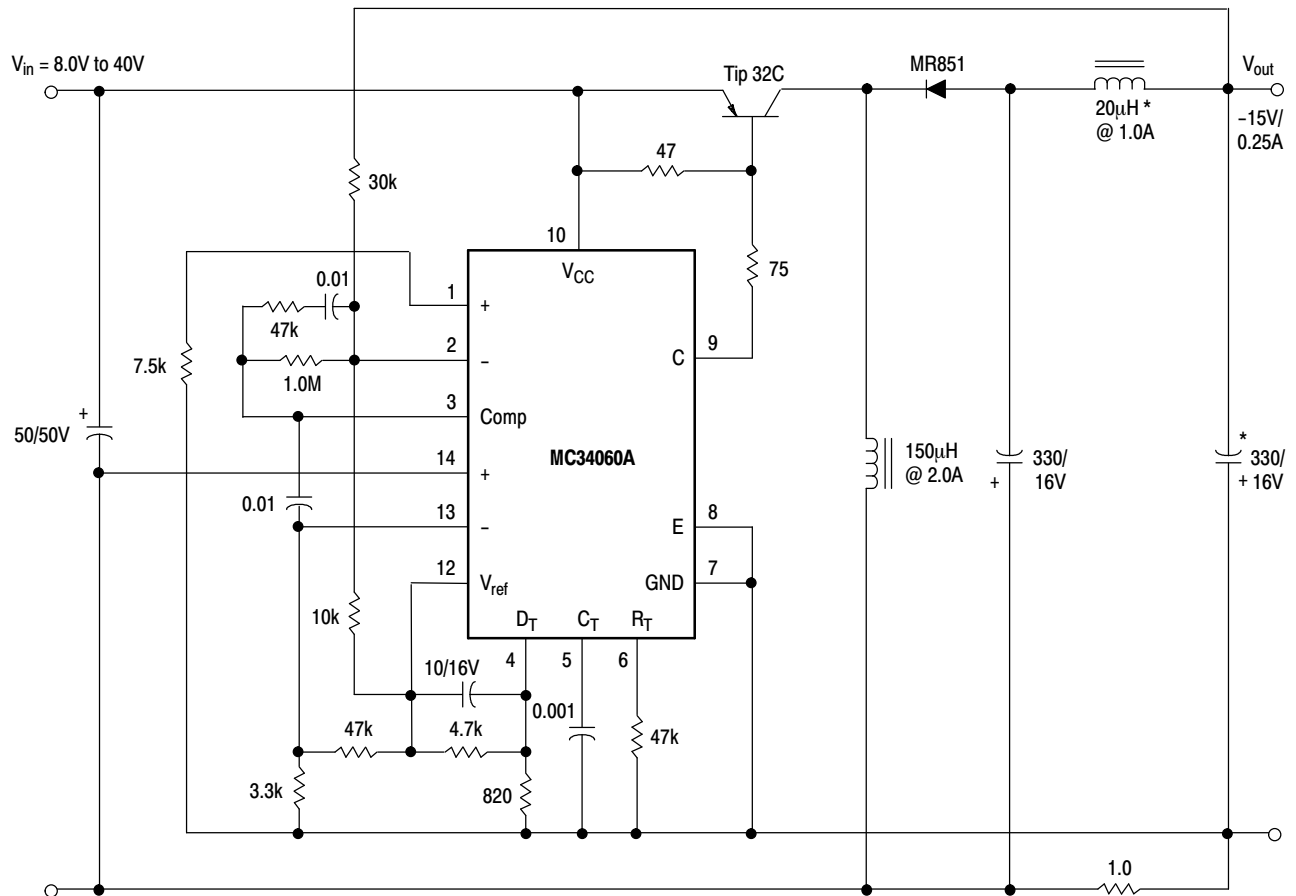

Test	Conditions	Results
Line Regulation	$V_{in} = 8.0 \text{ V to } 40 \text{ V}$, $I_O = 250 \text{ mA}$	52 mV 0.35%
Load Regulation	$V_{in} = 12 \text{ V}$, $I_O = 1.0 \text{ to } 250 \text{ mA}$	47 mV 0.32%
Output Ripple	$V_{in} = 12 \text{ V}$, $I_O = 250 \text{ mA}$	10 mV p-p P.A.R.D.
Short Circuit Current	$V_{in} = 12 \text{ V}$, $R_L = 0.1 \Omega$	330 mA
Efficiency	$V_{in} = 12 \text{ V}$, $I_O = 250 \text{ mA}$	86%

*Optional circuit to minimize output ripple

Figure 21. Step-Up/Down Voltage Inverting Converter with Soft-Start and Current Limiting

MC34060A, MC33060A

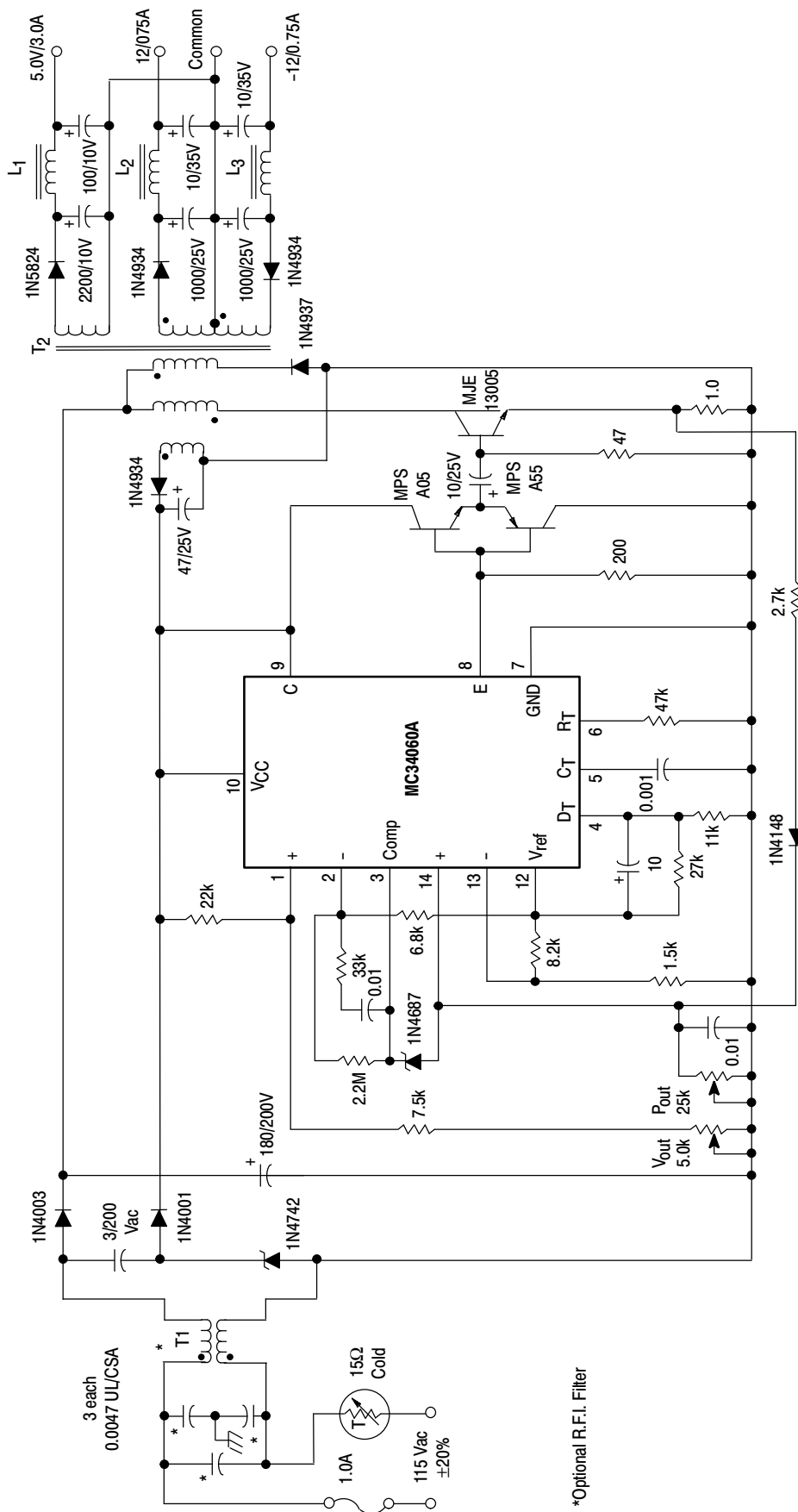

T1 – Coilcraft W2961
T2 – Core: Coilcraft 11-464-16,
 0.025" gap in each leg.
 Bobbin: Coilcraft 37-573
 Windings:
 Primary, 2 each, 75 turns #25 Awg Bifilar wound
 Feedback: 15 turns #26 Awg
 Secondary, 5.0 V, 6 turns @33 Awg Bifilar wound
 Secondary, 2 each, 14 turns #24 Awg Bifilar wound
L1 – Coilcraft Z7156, 15 μH @ 5.0 A
L2, L3 – Coilcraft Z7157, 25 μH @ 1.0 A

Test	Conditions	Results
Line Regulation 5.0 V	$V_{in} = 95 \text{ Vac}$ to 135 Vac, $I_O = 3.0 \text{ A}$	20 mV 0.40%
Line Regulation ±12 V	$V_{in} = 95 \text{ Vac}$ to 135 Vac, $I_O = \pm 0.75 \text{ A}$	52 mV 0.26%
Load Regulation 5.0 V	$V_{in} = 115 \text{ Vac}$, $I_O = 1.0 \text{ A}$ to 4.0 A	476 mV 9.5%
Load Regulation ±12 V	$V_{in} = 115 \text{ Vac}$, $I_O = \pm 0.4 \text{ A}$ to $\pm 0.9 \text{ A}$	300 mV 2.5%
Output Ripple 5.0 V	$V_{in} = 115 \text{ Vac}$, $I_O = 3.0 \text{ A}$	45 mV p-p P.A.R.D.
Output Ripple ±12 V	$V_{in} = 115 \text{ Vac}$, $I_O = \pm 0.75 \text{ A}$	75 mV p-p P.A.R.D.
Efficiency	$V_{in} = 115 \text{ Vac}$, $I_O 5.0 \text{ V} = 3.0 \text{ A}$ $I_O \pm 12 \text{ V} = \pm 0.75 \text{ A}$	74%

Figure 22. 33 W Off-Line Flyback Converter with Soft-Start and Primary Power Limiting

MC34060A, MC33060A

ORDERING INFORMATION

Device	Operating Temperature Range	Package	Shipping [†]
MC34060ADG	$T_A = 0^\circ \text{ to } +70^\circ\text{C}$	SOIC-14 (Pb-Free)	55 Units / Rail
MC34060ADR2G		SOIC-14 (Pb-Free)	2500 / Tape & Reel
MC34060APG		PDIP-14 (Pb-Free)	25 Units / Rail
MC33060ADG	$T_A = -40^\circ \text{ to } +85^\circ\text{C}$	SOIC-14 (Pb-Free)	55 Units / Rail
MC33060ADR2G		SOIC-14 (Pb-Free)	2500 / Tape & Reel
MC33060APG		PDIP-14 (Pb-Free)	25 Units / Rail

[†]For information on tape and reel specifications, including part orientation and tape sizes, please refer to our Tape and Reel Packaging Specifications Brochure, BRD8011/D.

MC34060A, MC33060A

PACKAGE DIMENSIONS

SOIC-14
CASE 751A-03
ISSUE H

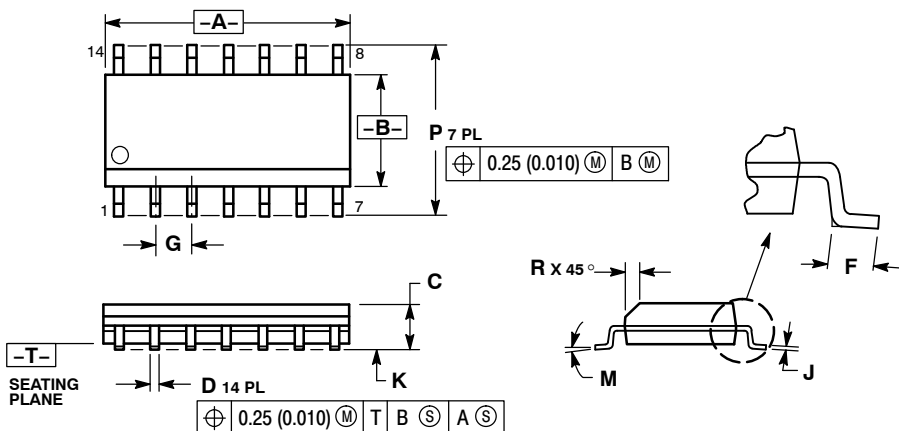

- NOTES:
1. DIMENSIONING AND TOLERANCING PER ANSI Y14.5M, 1982.
 2. CONTROLLING DIMENSION: MILLIMETER.
 3. DIMENSIONS A AND B DO NOT INCLUDE MOLD PROTRUSION.
 4. MAXIMUM MOLD PROTRUSION 0.15 (0.006) PER SIDE.
 5. DIMENSION D DOES NOT INCLUDE DAMBAR PROTRUSION. ALLOWABLE DAMBAR PROTRUSION SHALL BE 0.127 (0.005) TOTAL IN EXCESS OF THE D DIMENSION AT MAXIMUM MATERIAL CONDITION.

DIM	MILLIMETERS		INCHES	
	MIN	MAX	MIN	MAX
A	8.55	8.75	0.337	0.344
B	3.80	4.00	0.150	0.157
C	1.35	1.75	0.054	0.068
D	0.35	0.49	0.014	0.019
F	0.40	1.25	0.016	0.049
G	1.27 BSC		0.050 BSC	
J	0.19	0.25	0.008	0.009
K	0.10	0.25	0.004	0.009
M	0°	7°	0°	7°
P	5.80	6.20	0.228	0.244
R	0.25	0.50	0.010	0.019

SOLDERING FOOTPRINT*

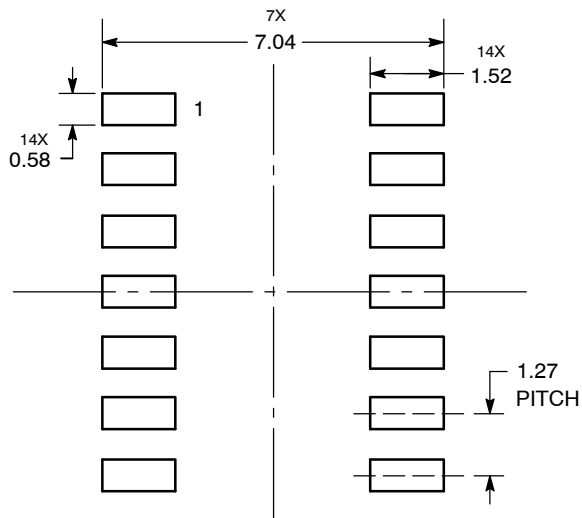

DIMENSIONS: MILLIMETERS

*For additional information on our Pb-Free strategy and soldering details, please download the ON Semiconductor Soldering and Mounting Techniques Reference Manual, SOLDERRM/D.

MC34060A, MC33060A

PACKAGE DIMENSIONS

PDIP-14
CASE 646-06
ISSUE P

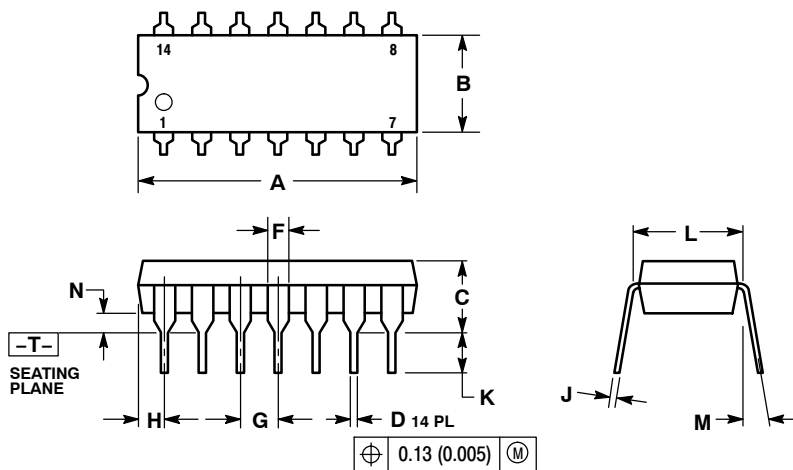

NOTES:

1. DIMENSIONING AND TOLERANCING PER ANSI Y14.5M, 1982.
2. CONTROLLING DIMENSION: INCH.
3. DIMENSION L TO CENTER OF LEADS WHEN FORMED PARALLEL.
4. DIMENSION B DOES NOT INCLUDE MOLD FLASH.
5. ROUNDED CORNERS OPTIONAL.

DIM	INCHES		MILLIMETERS	
	MIN	MAX	MIN	MAX
A	0.715	0.770	18.16	19.56
B	0.240	0.260	6.10	6.60
C	0.145	0.185	3.69	4.69
D	0.015	0.021	0.38	0.53
F	0.040	0.070	1.02	1.78
G	0.100 BSC		2.54 BSC	
H	0.052	0.095	1.32	2.41
J	0.008	0.015	0.20	0.38
K	0.115	0.135	2.92	3.43
L	0.290	0.310	7.37	7.87
M	---	10°	---	10°
N	0.015	0.039	0.38	1.01

SWITCHMODE is a trademark of Semiconductor Components Industries, LLC.

ON Semiconductor and **ON** are registered trademarks of Semiconductor Components Industries, LLC (SCILLC). SCILLC reserves the right to make changes without further notice to any products herein. SCILLC makes no warranty, representation or guarantee regarding the suitability of its products for any particular purpose, nor does SCILLC assume any liability arising out of the application or use of any product or circuit, and specifically disclaims any and all liability, including without limitation special, consequential or incidental damages. "Typical" parameters which may be provided in SCILLC data sheets and/or specifications can and do vary in different applications and actual performance may vary over time. All operating parameters, including "Typicals" must be validated for each customer application by customer's technical experts. SCILLC does not convey any license under its patent rights nor the rights of others. SCILLC products are not designed, intended, or authorized for use as components in systems intended for surgical implant into the body, or other applications intended to support or sustain life, or for any other application in which the failure of the SCILLC product could create a situation where personal injury or death may occur. Should Buyer purchase or use SCILLC products for any such unintended or unauthorized application, Buyer shall indemnify and hold SCILLC and its officers, employees, subsidiaries, affiliates, and distributors harmless against all claims, costs, damages, and expenses, and reasonable attorney fees arising out of, directly or indirectly, any claim of personal injury or death associated with such unintended or unauthorized use, even if such claim alleges that SCILLC was negligent regarding the design or manufacture of the part. SCILLC is an Equal Opportunity/Affirmative Action Employer. This literature is subject to all applicable copyright laws and is not for resale in any manner.

PUBLICATION ORDERING INFORMATION

LITERATURE FULFILLMENT:
Literature Distribution Center for ON Semiconductor
P.O. Box 5163, Denver, Colorado 80217 USA
Phone: 303-675-2175 or 800-344-3860 Toll Free USA/Canada
Fax: 303-675-2176 or 800-344-3867 Toll Free USA/Canada
Email: orderlit@onsemi.com

N. American Technical Support: 800-282-9855 Toll Free
USA/Canada
Europe, Middle East and Africa Technical Support:
Phone: 421 33 790 2910
Japan Customer Focus Center
Phone: 81-3-5773-3850

ON Semiconductor Website: www.onsemi.com
Order Literature: <http://www.onsemi.com/orderlit>

For additional information, please contact your local Sales Representative