

MC33468

Variable Frequency Micropower Step-up DC-DC Converter

The MC33468 is a micropower step-up switching voltage regulator, specifically designed for handheld and pager applications, to provide a regulated output voltage using a minimum of external parts. This device features a quiescent bias current of 3.0 μA typical.

The MC33468 features a highly accurate voltage reference, an error amplifier, an oscillator, a variable frequency modulation (VFM) controller, a drive pin (EXT) for an external transistor, and feedback resistors.

The Vout pin is fixed at 2V in the IC. The output of the converter with an inductor, a diode, a capacitor, a drive transistor, and feed-back resistors can have an output of 30V.

MC33468 Features:

- Low Quiescent Bias Current of 3.0 μA
- High Output Voltage Accuracy of $\pm 2.5\%$
- Low Startup Voltage of 0.8 V at No Load
- Output Voltage Set With External Resistors
- Operating Temperature Range: -40°C to $+85^\circ\text{C}$
- Surface Mount Package

ORDERING INFORMATION

Device	Output Voltage	Marking	Reel Size	Tape Width	Quantity
MC33468SN-20ATR	2.0	0KXX*	7"	8 mm	3000

* "XX" denotes the lot number.

PIN DESCRIPTION

Pin No.	Symbol	Description
1	GND	Ground
2	V _{DD}	Input
3	EXT	External Transistor Drive
4	NC	No Connection
5	V _{OUT}	Voltage Output Pin (Fixed at 2V)

Representative Block Diagram

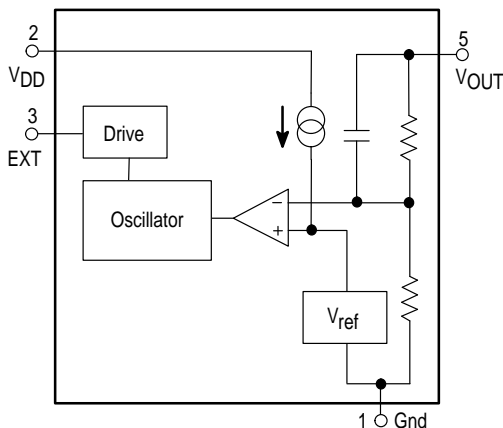

VARIABLE FREQUENCY MICROPOWER DC-to-DC CONVERTER

SEMICONDUCTOR TECHNICAL DATA



N SUFFIX
PLASTIC PACKAGE
CASE 1212
(SOT-23-5)

PIN CONNECTIONS

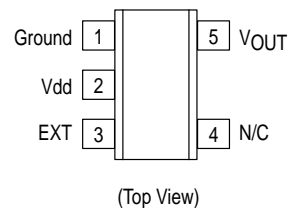

MC33468

MAXIMUM RATINGS (T_C = 25°C, unless otherwise noted.)

Rating	Symbol	Value	Unit
Power Supply Voltage (Transient)	V _{DD}	12	V
Power Supply Voltage (Operating)	V _{DD}	10	V
External Pin Voltage	V _{EXT}	-0.3 to V _{DD} + 0.3	V
EXT Pin Source/Sink Current	I _{EXT}	50/50	mA
Power Dissipation and Thermal Characteristics N Suffix, Plastic Package Case 1212 (SOT-23-5) Maximum Power Dissipation @ T _A = 250°C Thermal Resistance, Junction-to-Air	P _D R _{θJA}	150 667	mW °C/W
Operating Junction Temperature	T _J	125	°C
Operating Ambient Temperature	T _A	-40 to +85	°C
Storage Temperature Range	T _{stg}	-55 to +125	°C

ELECTRICAL CHARACTERISTICS (V_{DD} = 1.9 V, T_A = 25°C, unless otherwise noted.)

Characteristic	Symbol	Min	Typ	Max	Unit	Note ¹
----------------	--------	-----	-----	-----	------	-------------------

OSCILLATOR

Frequency	f _{osc}	-	180	-	kHz	B
Oscillator Minimum Supply Voltage (I _O = 0 mA)	V _{DD}	-	0.7	0.8	V	B
Oscillator Duty Cycle	D	65	75	-	%	B

EXT OUTPUT

ON State Source Current (V _{EXT} = GND)	I _{source}	1.5	-	-	mA	C
OFF State Sink Current (V _{EXT} = 1.9 V)	I _{sink}	1.5	-	-	mA	D

TOTAL DEVICE

Output Voltage	V _{OUT}	1.950	2.000	2.050	V	
Quiescent Bias Current (V _{OUT} = 1.9 V, I _O = 0 mA)	I _Q	-	15	25	μA	A
Quiescent Bias Current (V _{OUT} = 2.1 V, I _O = 0 mA)	I _Q	-	3.0	5.0	μA	A
Internal Resistor (V _{OUT} to GND)	R _{Vout}	2.0	-	-	MΩ	
Output Voltage Temperature Coefficient I _{OUT} = 10 mA, -40°C ≤ T _A ≤ 85°C	$\frac{\Delta V_{OUT}}{\Delta T_A}$	-	±50	-	ppm/oc	E

1. Indicates test circuits shown on next page.

Figure 1. Output Voltage versus Output Current

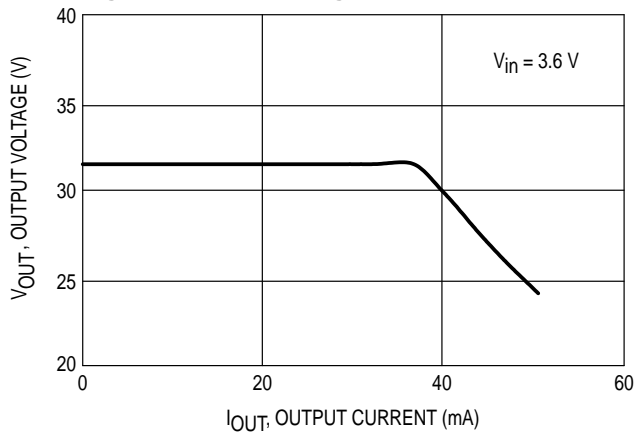
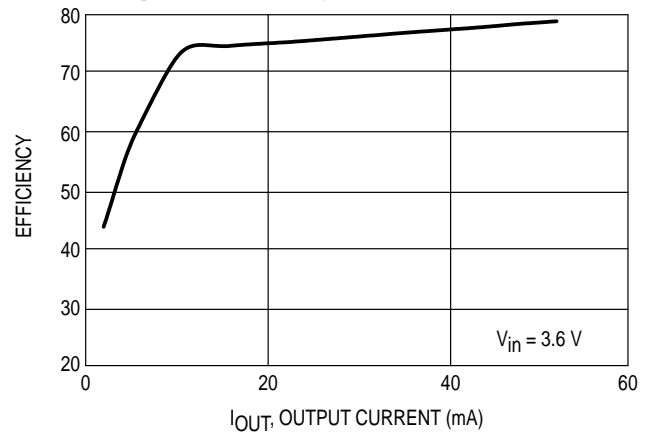
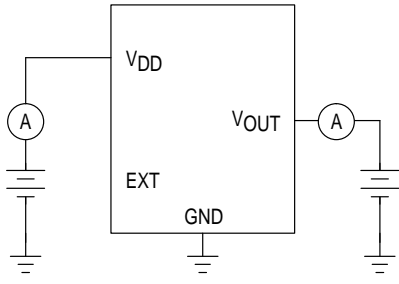

Figure 2. Efficiency versus Output Current



MC33468

A



B

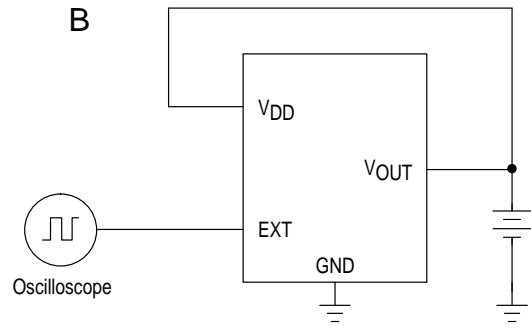

C

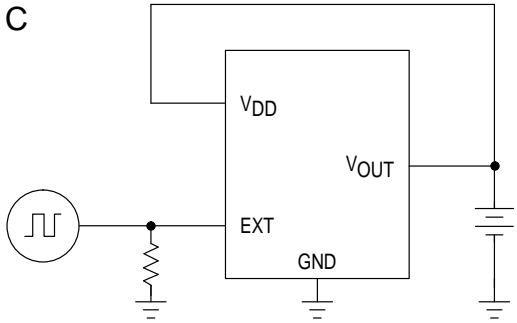

D

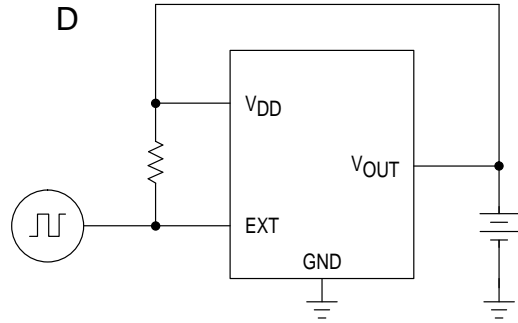

E

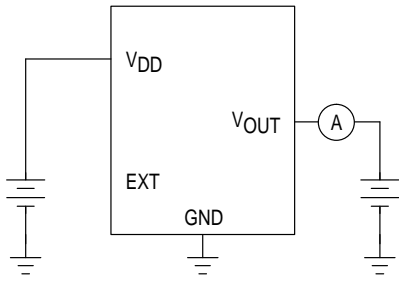

Figure 3. Test Circuit Schematics

DEFINITIONS

Quiescent Bias Current – Current which is used to operate the switching regulator chip and is not delivered to the load.
Leakage Current – Current drawn through a transistor junction, under a specified collector voltage, when the transistor is off.

FUNCTIONAL DESCRIPTION

Introduction

The MC33468 is a monolithic power switching regulator optimized for dc-to-dc converter applications where power drain must be minimized. The MC33468 uses Variable Frequency Modulation to step up the input DC voltage to a higher accurate output voltage. Potential applications include low power consumer products and battery powered portable products. Typical application circuits are shown in Figure 4.

Operating Description

The MC33468 converter operates as a fixed on-time, variable off-time voltage mode ripple regulator. Operation is intended to be in the discontinuous mode, where the inductor current ramps up to a peak value which is greater than or equal to twice the value of the dc input current during the

on-time of the transistor switch. During the off-time of the transistor switch, the inductor current ramps down to zero and remains at zero until another switching cycle begins.

Since the V_{DD} pin is connected to the input no external startup circuit is needed.

Oscillator

The oscillator frequency, is internally programmed to 180 kHz. The duty ratio of the oscillator is designed for a constant value of 0.75 nominal. Hence the nominal on-time of the power switch is:

$$t_{on} = \frac{D}{f_{osc}} = \frac{0.75}{(180 \text{ kHz})} = 4.16 \mu\text{s}$$

Feedback Comparator

The output voltage is sensed and fed to a high speed comparator noninverting input through an internal resistive divider. The comparator inverting input is connected to an internally trimmed reference.

With a voltage mode ripple converter operating under normal conditions, output switch conduction is initiated and terminated by the oscillator, off-time is controlled by the high speed voltage feedback comparator.

Figure 4. Typical 2.0 V Application with BJT

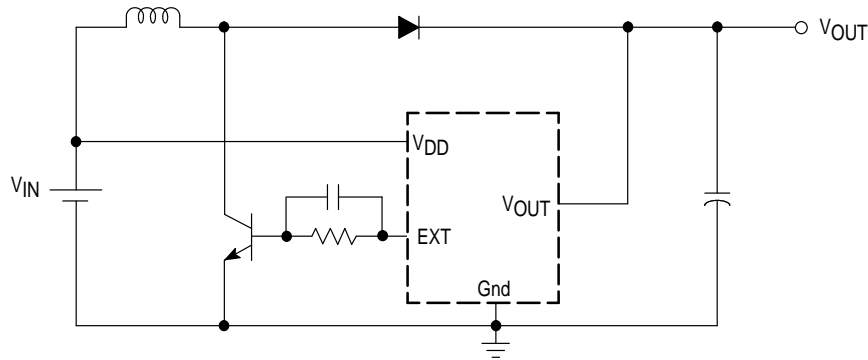

Figure 5. Design Equations for Step-Up

Calculation	Equation
t_{on}	$\frac{D}{f_{osc}}$
L	$< \frac{(n)(V_{in})^2(t_{on})}{P_O}$
$I_{L(avg)}$	I_{in}
$I_{L(pk)}$	$\frac{(V_{in} - V_{sat})(t_{on})}{L}$
$V_{ripple(pp)}$	$\approx \frac{(t_{on})(I_O)}{C_O}$

The following converter design characteristics must be chosen:

- V_{in} – Nominal Operating dc input voltage
- V_O – Desired dc output voltage
- I_O – Desired dc output current
- $V_{ripple(pp)}$ – Desired peak-to-peak output ripple voltage. For best performance the ripple voltage should be kept to a low value since it directly affects regulation. Capacitor C_O should have a low equivalent series resistance (ESR).

NOTE: 1. V_{sat} – Saturation voltage of the switching transistor.
 n – Estimated circuit efficiency.

MC33468

Figure 6. Typical 2.0 V Application with MOSFET

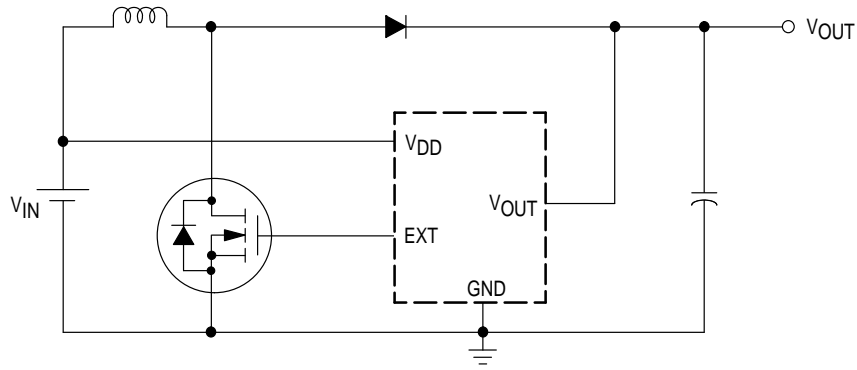

If input voltage is high enough, higher efficiency may be obtained by using a MOSFET as the switch transistor, in which no gate resistor or capacitor is needed.

MOSFET and BJT voltage rating (V_{DS} and V_{CE}) should be high enough to allow for spikes in voltage.

Figure 7. Typical Application for Output Voltages Over 2.0 V

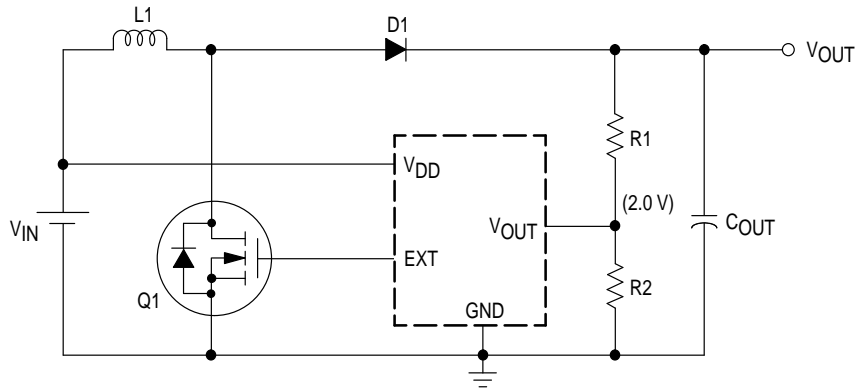

Inductor (L1)	CD54 (15 μ H)
Diode (D1)	MBRD540T1
Capacitor (C _{OUT})	47 μ F (Tantalum type)
Transistor (Q1)	MMFT3055VL
Resistor (R1)	150 k Ω
Resistor (R2)	10 k Ω

When choosing the output capacitor, ensure that the capacitor voltage is higher than V_{OUT} . Select an inductor with low DC resistance and high saturation. A Schottky diode is recommended for a lower voltage drop and faster switching.

Use external resistors that are much smaller resistance than the resistance internal to the IC (minimum of 2 M Ω). When R1 is much less than the internal resistance, the error is minimized.

MC33468

OUTLINE DIMENSIONS

N SUFFIX
 PLASTIC PACKAGE
 CASE 1212-01
 (SOT-23)
 ISSUE O

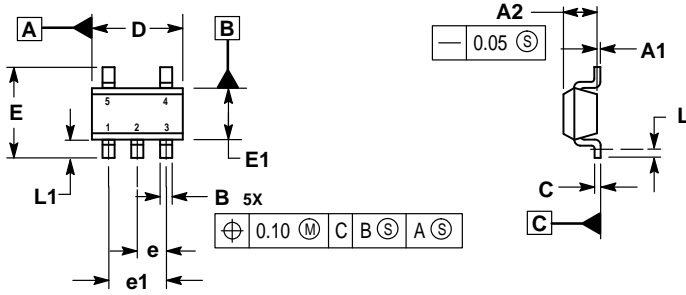

- NOTES:
 1. DIMENSIONS ARE IN MILLIMETERS.
 2. INTERPRET DIMENSIONS AND TOLERANCES PER ASME Y14.5M, 1994.
 3. DATUM C IS A SEATING PLANE.

MILLIMETERS		
DIM	MIN	MAX
A1	0.00	0.10
A2	1.00	1.30
B	0.30	0.50
C	0.10	0.25
D	2.80	3.00
E	2.50	3.10
E1	1.50	1.80
e	0.95 BSC	
e1	1.90 BSC	
L	0.20	—
L1	0.45	0.75

Recommended Footprint for Surface Mount Applications

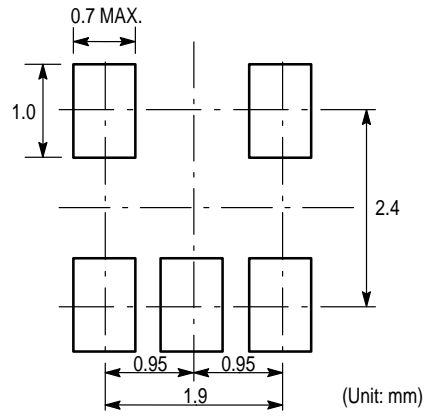

SOT-23-5

MC33468
NOTES

Motorola reserves the right to make changes without further notice to any products herein. Motorola makes no warranty, representation or guarantee regarding the suitability of its products for any particular purpose, nor does Motorola assume any liability arising out of the application or use of any product or circuit, and specifically disclaims any and all liability, including without limitation consequential or incidental damages. "Typical" parameters which may be provided in Motorola data sheets and/or specifications can and do vary in different applications and actual performance may vary over time. All operating parameters, including "Typicals" must be validated for each customer application by customer's technical experts. Motorola does not convey any license under its patent rights nor the rights of others. Motorola products are not designed, intended, or authorized for use as components in systems intended for surgical implant into the body, or other applications intended to support or sustain life, or for any other application in which the failure of the Motorola product could create a situation where personal injury or death may occur. Should Buyer purchase or use Motorola products for any such unintended or unauthorized application, Buyer shall indemnify and hold Motorola and its officers, employees, subsidiaries, affiliates, and distributors harmless against all claims, costs, damages, and expenses, and reasonable attorney fees arising out of, directly or indirectly, any claim of personal injury or death associated with such unintended or unauthorized use, even if such claim alleges that Motorola was negligent regarding the design or manufacture of the part. Motorola and  are registered trademarks of Motorola, Inc. Motorola, Inc. is an Equal Opportunity/Affirmative Action Employer.

Mfax is a trademark of Motorola, Inc.

How to reach us:

USA/EUROPE/Locations Not Listed: Motorola Literature Distribution;
P.O. Box 5405, Denver, Colorado 80217. 1-303-675-2140 or 1-800-441-2447

JAPAN: Motorola Japan Ltd.; SPD, Strategic Planning Office, 141,
4-32-1 Nishi-Gotanda, Shinagawa-ku, Tokyo, Japan. 81-3-5487-8488

Customer Focus Center: 1-800-521-6274

Mfax™: RMFAX0@email.sps.mot.com – TOUCHTONE 1-602-244-6609
Motorola Fax Back System – US & Canada ONLY 1-800-774-1848
– http://sps.motorola.com/mfax/

ASIA/PACIFIC: Motorola Semiconductors H.K. Ltd.; Silicon Harbour Centre,
2, Dai King Street, Tai Po Industrial Estate, Tai Po, N.T., Hong Kong.
852-26629298

HOME PAGE: <http://motorola.com/sps/>

