

*Technical Summary*

**Integrated Multiprotocol Processor (IMP)**

The IMP is a very large-scale integration (VLSI) device incorporating the main building blocks needed for the design of a wide variety of controllers. The device is especially suitable to applications in the communications industry. The IMP is the first device to offer the benefits of a closely coupled, industry-standard, MC68000/MC68008 microprocessor core and a flexible communications architecture. This multichannel communications device may be configured to support a number of popular industry interfaces, including those for the Integrated Services Digital Network (ISDN) basic rate and terminal adaptor applications. Through a combination of architectural and programmable features, concurrent operation of different protocols is easily achieved using the IMP. Data concentrators, line cards, bridges, and gateways are examples of suitable applications for this versatile device.

4

The IMP is a high-density complementary metal-oxide semiconductor (HCMOS) device consisting of an MC68000/MC68008 microprocessor core, a system integration block (SIB), and a communications processor (CP). The MC68302 block diagram is shown in Figure 1.

This document contains information on a new product. Specifications and information herein are subject to change without notice.

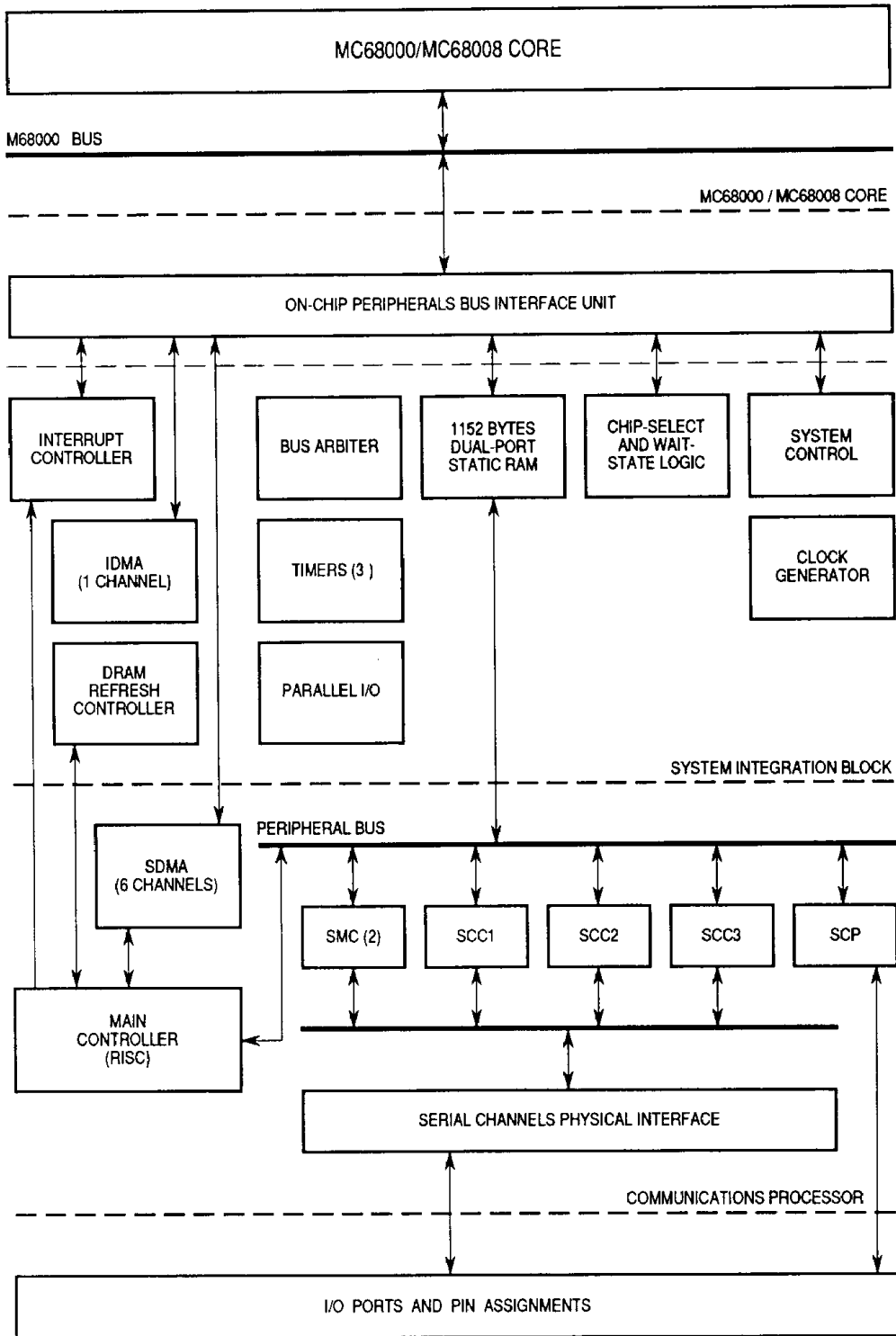

Figure 1. Block Diagram

The features of the IMP are as follows:

- MC68000/MC68008 Microprocessor Core Supporting a 16- or 8-Bit M68000 Family
- SIB including:
  - Independent Direct Memory Access (IDMA) Controller
  - Interrupt Controller with Two Modes of Operation
  - Parallel Input/Output (I/O) Ports, Some with Interrupt Capability
  - On-Chip 1152 Bytes of Dual-Port Random-Access Memory (RAM)
  - Three Timers, Including a Watchdog Timer
  - Four Programmable Chip-Select Lines with Wait-State Logic
  - Programmable Address Mapping of Dual-Port RAM and IMP Registers
  - On-Chip Clock Generator with an Output Clock Signal
  - System Control
    - System Control Register
    - Bus Arbitration Logic with Low Interrupt Latency Support
    - Hardware Watchdog for Monitoring Bus Activity
    - Low Power (Standby) Modes
    - Disable CPU Logic (M68000)
    - Freeze Control for Debugging Selected On-Chip Peripherals
    - DRAM Refresh Controller
- CP including:
  - Main Controller (RISC Processor)
  - Three Full-Duplex Serial Communication Controllers (SCCs)
  - Six Serial Direct Memory Access (SDMA) Channels Dedicated to the Three SCCs
  - Flexible Physical Interface Accessible by SCCs for Interchip Digital Link (IDL), General Circuit Interface (GCI, see note), Pulse Code Modulation (PCM), and Nonmultiplexed Serial Interface (NMSI) Operation
  - Serial Communication Port (SCP) for Synchronous Communication
  - Serial Management Controllers (SMCs) for IDL and GCI Channels

#### **NOTE**

GCI is sometimes referred to as IOM2.

# GENERAL DESCRIPTION

The MC68302 uses a microprocessor architecture which has peripheral devices connected to the system bus through a dual-port memory. Various parameters, counters, and all memory buffer descriptor tables reside in the dual-port RAM. The receive and transmit data buffers may be located in this on-chip RAM or in the off-chip system RAM (see Figure 2). Six DMA channels are dedicated to the six serial ports (receive and transmit for each of the three SCC channels). If an SCC channel's data is programmed to be located in the external RAM, the CP main controller (RISC processor) will program the corresponding DMA channel to perform the required accesses. If the data resides in the on-chip dual-port RAM, then the CP main controller accesses the RAM with one clock cycle access and no arbitration delays.

4

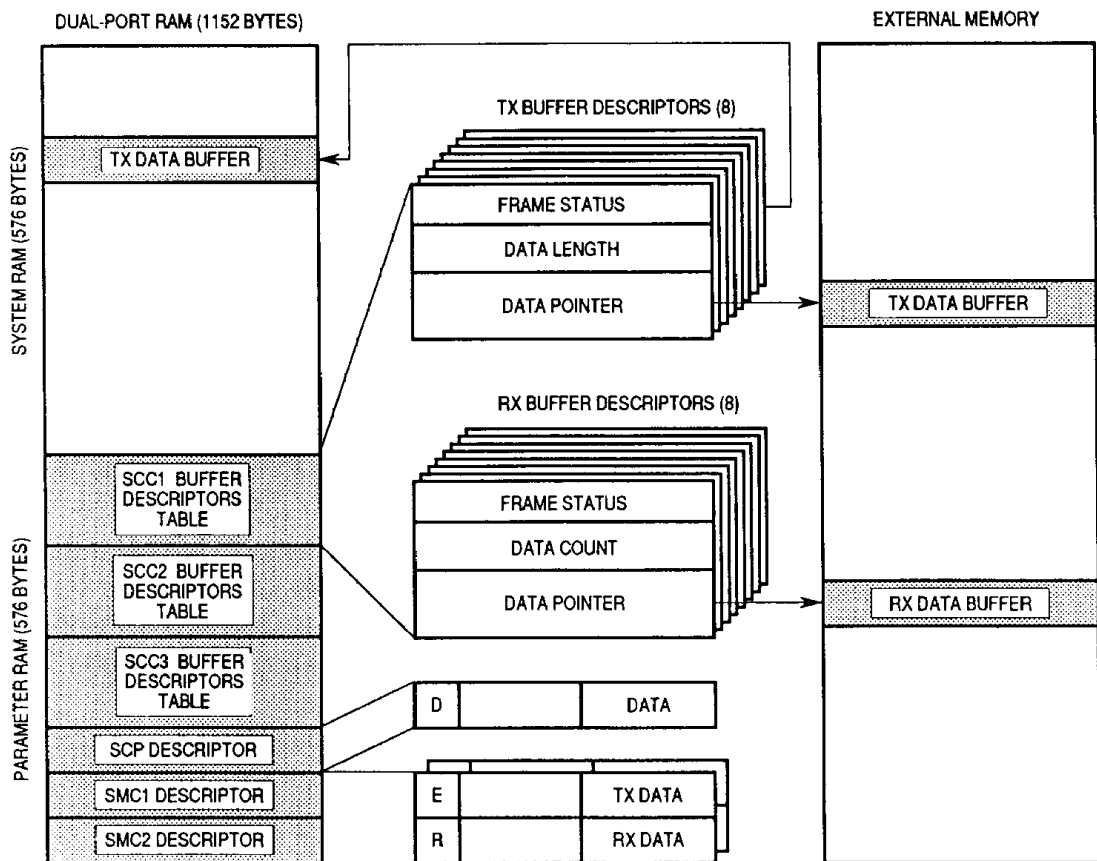

Figure 2. Buffer Memory Structure

The buffer memory structure of the MC68302 can be configured by software to closely match I/O channel requirements. The interrupt structure is also programmable to relieve the on-chip MC68000/MC68008 core from bit manipulation functions for peripherals, allowing the processor to perform application software or protocol processing.

In some cases, the interface to equipment or proprietary networks may require the use of standard control and data signals. For these signals, the MC68302 can be programmed to use the NMSI mode. This mode is available for one, two, or all three SCC ports; remaining ports may then use one of the multiplexed interface modes: IDL, GCI, or PCM.

## MC68000/MC68008 CORE OVERVIEW

The MC68302 allows operation either in the full MC68000 mode with a 16-bit data bus or in the MC68008 mode with an 8-bit data bus.

4

Refer to FR68K/D, *M68000 Family Reference*, and to M68000UM/AD, *M68000 8-/16-/32-Bit Microprocessors User's Manual*, for information on the MC68000 and MC68008 microprocessors.

## SYSTEM INTEGRATION BLOCK (SIB)

The MC68302 has an SIB which simplifies the task of hardware and software design. The IDMA controller eliminates the need for an external DMA controller on the system board. In addition, there is an interrupt controller that can be used in a dedicated mode to generate interrupt acknowledge signals without external logic. Similarly, the chip-select signals and wait-state logic eliminate the need to generate these signals externally.

The SIB includes the IDMA controller, interrupt controller, parallel I/O ports, dual-port RAM, three timers, chip-select logic, clock generator, and system control.

## IDMA Controller

The MC68302 has one IDMA channel and six serial DMA channels which operate concurrently with other CPU operations. The IDMA can operate in different modes of data transfer as programmed by the user. The six serial DMA channels for the three full-duplex SCC channels are transparent to the user, implementing bus-cycle-stealing data transfers controlled by the MC68302's internal RISC controller. These six channels have priority over the separate IDMA channel.

The IDMA controller can transfer data between any combination of memory and I/O devices. In addition, data may be transferred in either byte or word quantities, and the source and destination addresses may be either odd or even. Every IDMA cycle requires between two and four bus cycles, depending on the address boundary and transfer size. If both the source and destination addresses are even, the IDMA fetches one word of data and then immediately deposits it. If either the source or destination block begins on an odd boundary, the transfer takes more bus cycles.

The IDMA features are as follows:

- Memory-Memory, Memory-Peripheral, or Peripheral-Memory Data Transfers
- Operation with Data Blocks Located at Even or Odd Addresses
- Packing and Unpacking of Operands
- Fast Transfer Rates: Up to 4 MBps at 16 MHz with No Wait States
- Full Support of All Bus Exceptions: Halt, Bus Error, and Retry
- Flexible Request Generation
- Two Address Pointer Registers and One Counter Register
- Three I/O Lines for Externally Requested Data Transfers
- Asynchronous Bus Structure with 24-Bit Address and 8-/16-Bit Data Bus

## Interrupt Controller

The interrupt controller, which manages the priority of internal and external interrupt requests, generates a vector number during the CPU interrupt acknowledge cycle. Nested interrupts are fully supported.

The interrupt controller receives requests from internal sources (INRQ interrupts) such as the timers, the IDMA, the serial controllers, and the parallel I/O pins (port B). The interrupt controller allows the masking of each INRQ interrupt source. When multiple events within a peripheral can cause the interrupt, each of these events is also maskable.

The interrupt controller also receives external (EXRQ) requests. EXRQ interrupts are received by the IMP according to the operational mode selected. In the normal operational mode, EXRQ interrupts are encoded onto the  $\overline{\text{IPL}}$  lines. In the dedicated operational mode, EXRQ interrupts are presented directly as  $\overline{\text{IRQ7}}$ ,  $\overline{\text{IRQ6}}$ , and  $\overline{\text{IRQ1}}$ .

The interrupt controller block diagram is shown in Figure 3. The interrupt controller features are as follows:

- Two Operational Modes: Normal and Dedicated
- Eighteen Priority-Organized Interrupt Sources (Internal and External)
- Fully Nested Interrupt Environment
- Unique Vector Number for Each Internal/External Source
- Three Selectable Interrupt Request/Interrupt Acknowledge Pairs

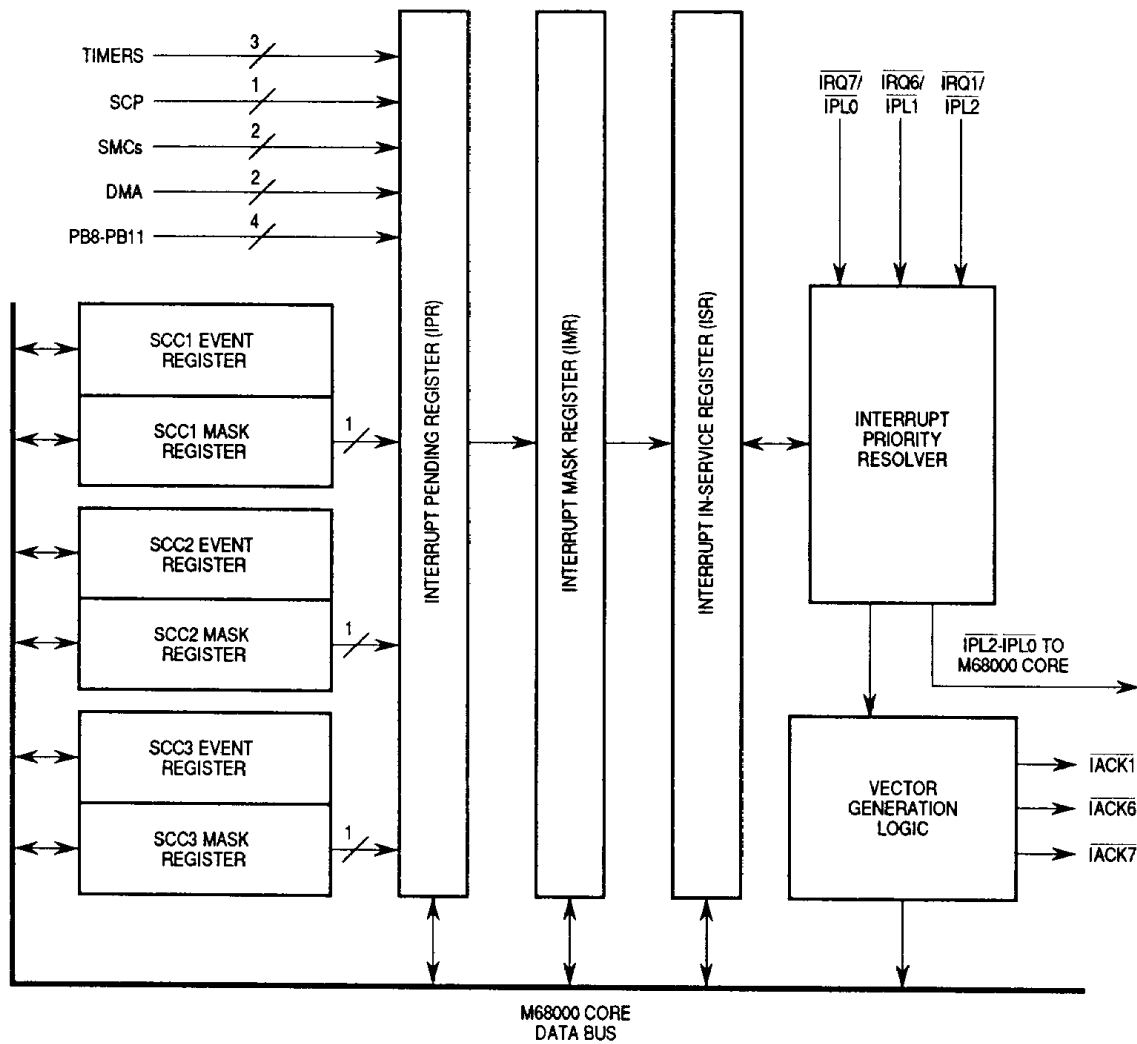

4

**Figure 3. Interrupt Controller Block Diagram**

## Parallel I/O Ports

Port A and port B are two general-purpose I/O ports. Each pin in the 16-bit port A may be configured as a general-purpose I/O pin or as a dedicated peripheral interface pin. Port B has 12 pins. Eight pins may be configured as general-purpose pins or as dedicated peripheral interface pins, and four are general-purpose pins, each with interrupt capability.

## Dual-Port RAM

The IMP has 1152 bytes of RAM configured as a dual-port memory. The RAM can be accessed by the internal RISC controller or one of three bus masters: the M68000 core, an external bus master, or the IDMA. All internal bus masters synchronously access the RAM with no wait states. External bus masters can access the RAM and registers synchronously or asynchronously.

4

The RAM is divided into two parts. There are 576 bytes used as a parameter RAM, which includes pointers, counters, and registers for the serial ports. The other 576 bytes may be used for system RAM, which may include data buffers, or may be used for other purposes such as a no-wait-state cache.

## TIMERS

There are three timer units. Two units are identical, general-purpose timers; the third unit can be used to implement a watchdog timer function.

The two general-purpose timers are implemented with a timer mode register (TMR), a timer capture register (TCR), a timer counter (TCN), a timer reference register (TRR), and a timer event register (TER). The TMR contains the prescaler value programmed by the user. The watchdog timer, which has a TRR and TCN, uses a fixed prescaler value.

The timer features are as follows:

- Two General-Purpose Timer Units:
  - Maximum Period of 16 Seconds (at 16.67 MHz)
  - 60-Nanosecond Resolution (at 16.67 MHz)
  - Programmable Sources for the Clock Input
  - Input Capture Capability
  - Output Compare with Programmable Mode for the Output Pin
  - Free Run and Restart Modes



- One Watchdog Timer with a 16-Bit Counter and a Reference Register
  - Maximum Period of 16 Seconds (at 16.67 MHz)
  - 0.5-Millisecond Resolution (at 16 MHz)
  - Output Signal ( $\overline{\text{WDOG}}$ )
  - Interrupt Capability

## EXTERNAL CHIP-SELECT SIGNALS AND WAIT-STATE LOGIC

The MC68302 has a set of four programmable chip-select signals. Each chip select has an identical structure. For each memory area, an internally generated cycle-termination signal ( $\overline{\text{DTACK}}$ ) may be defined with up to six wait states to avoid using board space for cycle-termination logic. The four signals may each support four different classes of memory, such as high-speed static RAM, slower dynamic RAM, EPROM, and nonvolatile RAM. The chip-select and wait-state generation logic is active for all potential bus masters.

4

## CLOCK GENERATOR

The MC68302 has an on-chip clock generator which supplies internal and external high-speed clocks (up to 16.67 MHz). The clock circuitry uses three dedicated pins: EXTAL, XTAL, and CLKO.

## SYSTEM CONTROL

The IMP system control consists of a system control register (SCR) containing bits for the following system control functions:

- System Status and Control Logic
- Bus Arbitration Logic with Low Interrupt Latency
- Hardware Watchdog
- Low Power (Standby) Modes
- Disable CPU Logic (M68000)
- Freeze Control for Debugging On-Chip Peripherals
- $\overline{\text{AS}}$  Control during Read-Modify-Write Cycles

## System Control Register

The SCR is a 32-bit register that consists of system status and control bits, a bus arbiter control bit, hardware watchdog control bits, low power control bits, and freeze select bits. The eight most significant bits of the SCR report events recognized by the system control logic and set the corresponding bit in the SCR.

The low power modes are used, when no processing is required from the MC68000/MC68008 core, to reduce the system power consumption to its minimum value. The low power modes may be exited by an interrupt from an on-chip peripheral.

4

## Disable CPU Logic (M68000)

This control allows an external processor direct connection to the bus and to the IMP's peripherals while the on-chip M68000 core is disabled. Entered during a system reset (RESET and HALT asserted together), this mode configures the IMP on-chip peripherals for use with other MC68302 units or other processors and is an effective configuration for systems needing more than three SCCs.

## Freeze Control

This control is used to freeze the activity of selected peripherals and to debug systems. The IMP freezes its activity with no new interrupt requests, no memory accesses (internal or external), and no access of the serial channels. The IDMA controller completes any bus cycle in progress and releases bus ownership. No further bus cycles will be started as long as  $\overline{FRZ}$  remains asserted.

## DRAM REFRESH CONTROLLER

The CP main (RISC) controller can optionally handle the dynamic RAM (DRAM) refresh task without any intervention from the M68000 core. The refresh request can be generated from an MC68302 timer, baud rate generator, or externally. The DRAM refresh controller performs a standard M68000-type read cycle at programmable address sequences, with user-provided RAS and CAS generation.

## COMMUNICATIONS PROCESSOR

The CP in the MC68302 includes the main controller, six serial DMA channels, three SCCs, an SCP, and two SMCs.

Host software configures each communications channel, as required by the application, to include parameters, baud rates, physical channel interfaces desired, and interrupting conditions. Buffer structures are set up for receive and transmit channels. Up to eight frames may be received or transmitted without host software involvement. Selection of the interrupt interface is also set by register bits in the register space of the device.

Data is transmitted and received using the appropriate buffer descriptors and buffer data space for a given channel. The CP operates in a modified polling mode on each channel and buffer descriptor to identify buffers awaiting transmission and channels requiring servicing. The user sets a bit in the buffer descriptor of a transmit frame; when the CP polls and detects this bit, it will begin transmission. Generally, no other action is required to accomplish transmission.

## Main Controller

The main controller is a microcoded RISC processor that services all the serial channels. The main controller transfers data between the serial channels and internal/external RAM, executes host commands, and generates interrupts to the interrupt controller.

Data is transferred from the serial channel to the dual-port RAM or to the external memory through the peripheral bus. If data is transferred between the SCC channels and external memory, the main controller uses up to six serial DMA channels for the transfer. The main controller also controls all character and address comparison and cyclic redundancy check (CRC) generation and checking.

The execution unit includes the arithmetic logic unit (ALU), which performs arithmetic and logic operations on the registers.

## Serial Communication Controllers

The MC68302 has three independent SCCs. Each SCC can be configured to implement different protocols — for example, to perform a gateway function or to interface to an ISDN basic rate channel. To simplify programming, each protocol implementation uses identical data structures.

Five protocols are supported: high-level data link control (HDLC), binary synchronous communication (BISYNC), synchronous/asynchronous digital data

communications message protocol (DDCMP), V.110, universal asynchronous receiver transmitter (UART), and a fully transparent mode. To aid system diagnostics, each SCC may be configured to operate in either an echo or loopback mode. In echo mode, the IMP retransmits any signals received; in loopback mode, the IMP locally receives signals originating from itself.

The clock pins (RCLK, TCLK) for each SCC can be programmed for either an external or internal source, with user-programmable baud rates available for each SCC channel.

Each SCC also supports the standard modem control signals: request to send ( $\overline{RTS}$ ), clear to send ( $\overline{CTS}$ ), and carrier detect ( $\overline{CD}$ ). Other modem signals may be provided through the parallel I/O pins.

## 4

The SCC features are as follows:

- Programmable Baud Rate Generator Driven by the Internal or External Clock
- Data May Be Clocked by the Programmable Baud Rate Generator or Directly by an External Clock
- Provides Modem Signals  $\overline{RTS}$ ,  $\overline{CTS}$ , and  $\overline{CD}$
- Full-Duplex Operation
- Automatic Echo Mode
- Local Loopback Mode
- Baud Rate Generator Outputs Available Externally

The SCC HDLC mode key features are as follows:

- Flexible Data Buffers with Multiple Buffers per Frame Allowed
- Separate Interrupts for Frames and Buffers (Receive and Transmit)
- Four Address Comparison Registers with Mask
- Maintenance of Five 16-Bit Error Counters
- Flag/Abort/Idle Generation/Detection
- Zero Insertion/Deletion
- NRZ/NRZI Data Encoding
- 16-Bit or 32-Bit CRC-CCITT Generation/Checking
- Detection of Non-Octet Aligned Frames

- Detection of Frames That Are Too Long
- Programmable 0–15 FLAGS between Successive Frames
- Automatic Retransmission in Case of Collision

The SCC BISYNC mode key features are as follows:

- Flexible Data Buffers
- Eight Control Character Recognition Registers
- Automatic SYNC1 and SYNC2 Detection
- SYNC/DLE Stripping and Insertion
- CRC-16 and LRC Generation/Checking
- Parity (VRC) Generation/Checking
- Supports BISYNC Transparent Operation (Use of DLE Characters)
- Supports Promiscuous (Totally Transparent) Reception and Transmission
- Maintains Parity Error Counter
- External SYNC Support
- Reverse Data Mode

The SCC DDCMP mode key features are as follows:

- Synchronous or Asynchronous DDCMP Links Supported
- Flexible Data Buffers
- Four Address Comparison Registers with Mask
- Automatic Frame Synchronization
- Automatic Message Synchronization by Searching for SOH, ENQ, or DLE
- CRC-16 Generation/Checking
- NRZ/NRZI Data Encoding
- Maintenance of Four 16-Bit Error Counters

The SCC V.110 mode key features are as follows:

- Provides Synchronization and Reception of 80-Bit Frames
- Automatic Detection of Framing Errors
- Allows Transmission of the 80-Bit Frame

The SCC UART mode key features are as follows:

- Flexible Message-Oriented Data Buffers
- Multidrop Operation
- Receiver Wakeup on Idle Line or Address Mode
- Eight Control Character Comparison Registers
- Two Address Comparison Registers
- Four 16-Bit Error Counters
- Programmable Data Length (7–8 Bits)
- Programmable 1 or 2 Stop Bits with Fractional Stop Bits
- Even/Odd/Force/No Parity Generation
- Even/Odd/No Parity Check
- Frame Error, Noise Error, Break, and Idle Detection
- Transmits Idle and Break Sequences
- Freeze Transmission Option
- Maintenance of Four 16-Bit Error Counters
- Provides Asynchronous Link over which DDCMP May Be Used
- Flow Control Character Transmission Supported

## Serial Communication Port

The SCP is a full-duplex, synchronous, character-oriented channel which provides a three-wire interface (TXD, RXD, and clock). The SCP consists of independent transmitter and receiver sections and a common SCP clock generator. The transmitter and receiver section use the same clock, which is derived from the main clock by an on-chip baud rate generator. The MC68302 is an SCP master, generating both the enable and the clock signals. The enable signals may be generated by the general-purpose I/O pins.

The SCP allows the MC68302 to communicate with a variety of serial devices for the exchange of status and control information using a subset of the Motorola serial peripheral interface (SPI). Such devices may include industry-standard CODECs (e.g., Motorola MC145474 S/T transceiver) and other microcontrollers and peripherals.

The SCP can be configured to operate in a local loopback mode, which is useful for diagnostic functions. The receiver and the transmitter operate normally in these modes.

The SCP features are as follows:

- Three-Wire Interface (SPTXD, SPRXD, and SPCLK)
- Full-Duplex Operation
- Clock Rate up to 4.96 MHz
- Programmable Baud Rate Generator
- Local Loopback Capability for Testing Purposes

## Serial Management Controllers

4

The SMCs are two synchronous, full-duplex ports that may be configured to operate in either IDL or GCI mode to handle the maintenance and control portions of these interfaces. The SMC ports are not used in PCM or NMSI modes. The SMC features are as follows:

- Two Modes of Operation — IDL and GCI
- Local Loopback Capability for Testing Purposes
- Full-Duplex Operation
- SMC1 in GCI Mode Detects Collisions on the D Channel

## Serial Channels Physical Interface

The serial channels physical interface connects the physical layer serial lines and the serial controllers (three SCCs and two SMCs). The interface implements both the routing and the time-division multiplexing for the full ISDN bandwidth. It supports four buses: IDL, GCI, PCM, and NMSI (a nonmultiplexed modem interface). The multiplexed modes (IDL, GCI, and PCM) also allow multiple channels (e.g., ISDN B channels) or user-defined subchannels to be assigned to a given SCC. The serial interface also supports two testing modes: echo and loopback.

For the IDL and GCI buses, support of management functions in the frame structure is provided by the SCP or SMCs, respectively. Refer to Figure 4 for the serial channels physical interface block diagram.

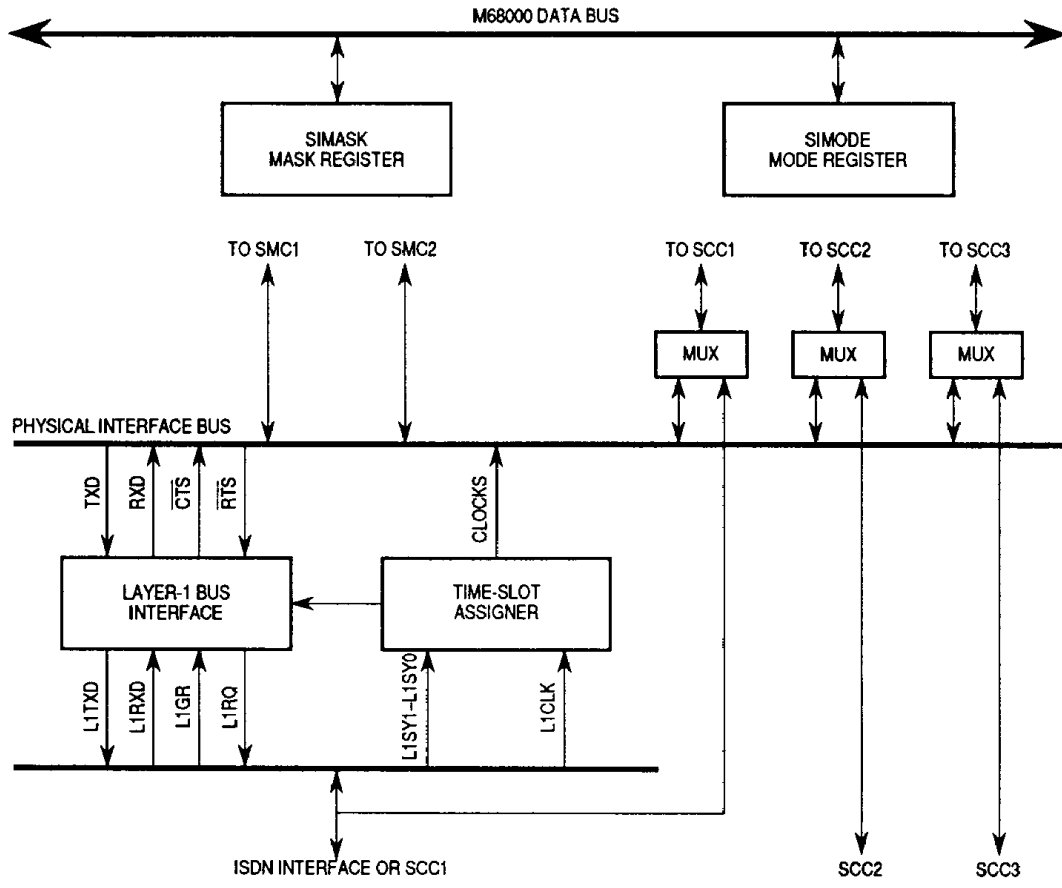

Figure 4. Serial Channels Physical Interface Block Diagram



## SIGNAL DESCRIPTIONS

The input and output signals of the MC68302 are organized into functional groups as shown in Table 1 and Figure 5. Refer to MC68302 UM/AD, *MC68302 Integrated Multiprotocol Processor User's Manual*, for detailed information on the MC68302 signals.

**Table 1. Signal Definitions**

Functional Group	Signals	Num.
Clocks	XTAL, EXTAL, CLKO	3
System Control	RESET, HALT, BERR, BUSW, DISCPU	5
Address Bus	A23-A1	23
Data Bus	D15-D0	16
Bus Control	AS, R/W, UDS/A0, LDS/DS, DTACK	5
Bus Control	RMC, IAC, BCLR	3
Bus Arbitration	BR, BG, BGACK	3
Interrupt Control	IPL2-IPL0, FC2-FC0, AVEC	7
NMSI1/ISDN I/F	RXD, TXD, RCLK, TCLK, CD, CTS, RTS, BRG1	8
NMSI2/PIO	RXD, TXD, RCLK, TCLK, CD, CTS, RTS, SDS2	8
NMSI3/SCP/PIO	RXD, TXD, RCLK, TCLK, CD, CTS, RTS, PA12	8
IDMA/PAIO	DREQ, DACK, DONE	3
IACK/PBIO	IACK7, IACK6, IACK1	3
Timer/PBIO	TIN2, TIN1, TOUT2, TOUT1, WDOG	5
PBIO	PB11-PB8	4
Chip Select	CS3-CS0	4
Testing	FRZ (2 Spare)	3
VDD		8
GND		13

### Power Pins

There are eight power pins (VDD).

### Ground Pins

There are thirteen ground pins (GND).

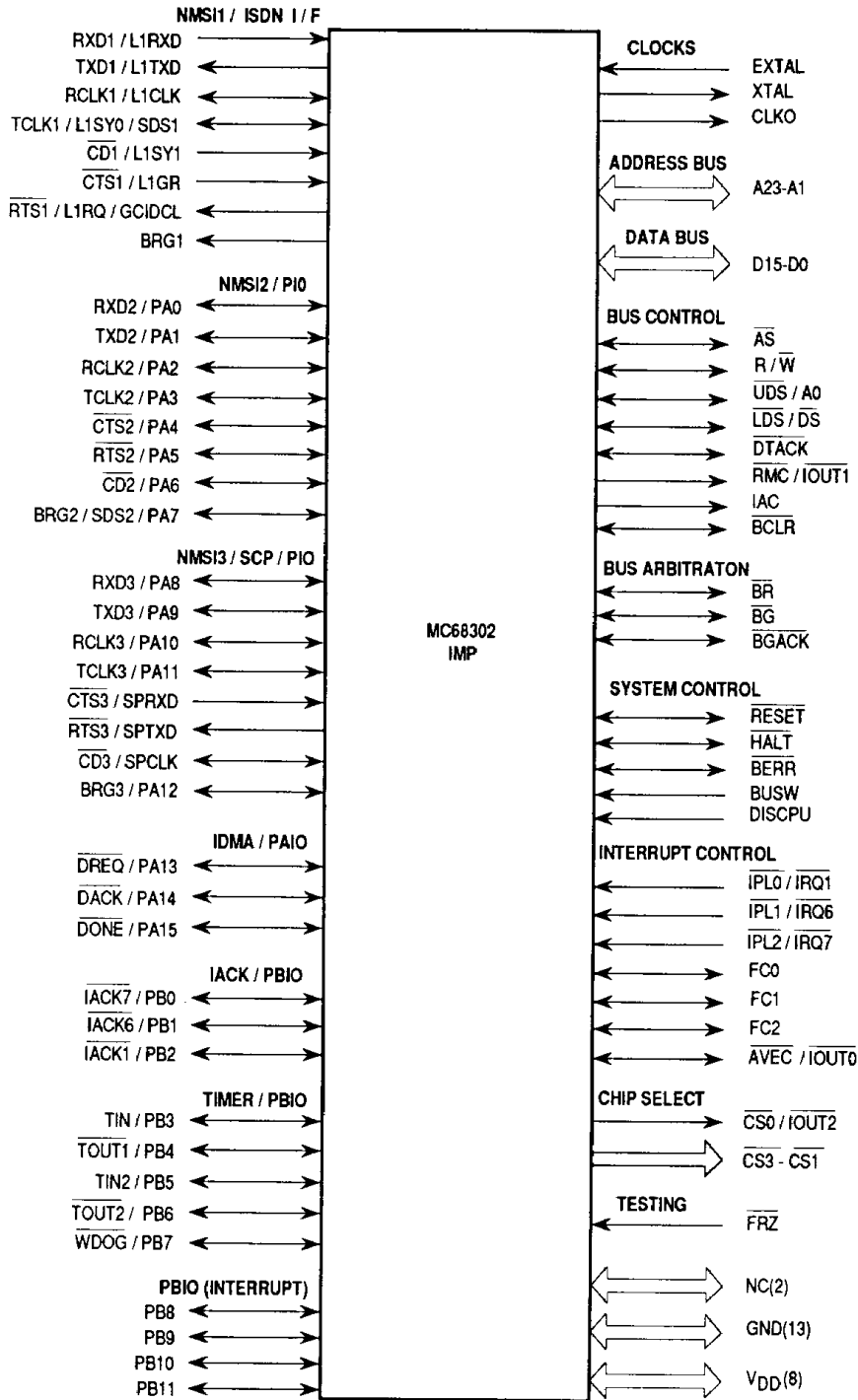

Figure 5. Functional Signal Groups

## ELECTRICAL SPECIFICATIONS

The AC specifications presented consist of output delays, input setup and hold times, and signal skew times. All signals are specified relative to an appropriate edge of the clock (CLKO pin) and possibly to one or more other signals.

### MAXIMUM RATINGS

Rating	Symbol	Value	Unit
Supply Voltage	$V_{DD}$	-0.3 to +7.0	V
Input Voltage	$V_{in}$	-0.3 to +7.0	V
Operating Temperature Range MC68302 MC68302I	$T_A$	0 to 70 0 to 85	°C
Storage Temperature Range	$T_{stg}$	-55 to +150	°C

This device contains circuitry to protect the inputs against damage due to high static voltages or electric fields; however, it is advised that normal precautions be taken to avoid application of any voltage higher than maximum-rated voltages to this high-impedance circuit. Reliability of operation is enhanced if unused inputs are tied to an appropriate logic voltage level (e.g., either GND or  $V_{DD}$ ).

4

### THERMAL CHARACTERISTICS

Characteristic	Symbol	Value	Unit
Thermal Resistance for PGA	$\theta_{JA}$	33	°C/W
Thermal Resistance for CQFP	$\theta_{JA}$	46	°C/W

$$T_J = T_A + (P_D \cdot \theta_{JA})$$

$$P_D = (V_{DD} \cdot I_{DD}) + P_{I/O}$$

where:

$P_{I/O}$  is the power dissipation on pins.

For  $T_A = 70^\circ\text{C}$  and  $P_D = 0.5\text{ W}$  @ 12.5 MHz,  $T_J = 88^\circ\text{C}$

## POWER CONSIDERATIONS

The average chip-junction temperature,  $T_J$ , in °C can be obtained from:

$$T_J = T_A + (P_D \cdot \theta_{JA}) \quad (1)$$

where:

$T_A$  = Ambient Temperature, °C

$\theta_{JA}$  = Package Thermal Resistance, Junction-to-Ambient, °C/W

$P_D$  =  $P_{INT} + P_{I/O}$

$P_{INT}$  =  $I_{DD} \times V_{DD}$ , Watts — Chip Internal Power

$P_{I/O}$  = Power Dissipation on Input and Output Pins — User Determined

For most applications  $P_{I/O} < 0.3 \cdot P_{INT}$  and can be neglected.

If  $P_{I/O}$  is neglected, an approximate relationship between  $P_D$  and  $T_J$  is:

$$P_D = K \div (T_J + 273^\circ\text{C}) \quad (2)$$

Solving equations (1) and (2) for K gives:

$$K = P_D \cdot (T_A + 273^\circ\text{C}) + \theta_{JA} \cdot P_D^2 \quad (3)$$

where K is a constant pertaining to the particular part. K can be determined from equation (3) by measuring  $P_D$  (at equilibrium) for a known  $T_A$ . Using this value of K, the values of  $P_D$  and  $T_J$  can be obtained by solving equations (1) and (2) iteratively for any value of  $T_A$ .

4

## POWER DISSIPATION

Characteristic	Symbol	Min	Max	Unit
Power Dissipation (Typical at 16.67 MHz) (See Note 1)	$P_D$	53	64	mA
Power Dissipation (Typical at 8 MHz) (See Note 1)	$P_D$	26	31	mA
Low Power Mode Dissipation (Typical at 16.67 MHz) (See Note 3)	$LP_D$	—	36	mA
Lowest Power Mode Dissipation (Typical at 16.67 MHz) (See Note 4)	$LP_D$	—	32	mA
Lowest Power Mode Dissipation (Typical at 50 kHz) (See Note 2)	$LP_D$	—	1	mA

### NOTES:

1. The values shown are typical. The typical value varies as shown, based on how many IMP on-chip peripherals are enabled and the rate at which they are clocked.
2. The stated frequency must be externally applied to EXTAL only after the IMP has been placed in the lowest power mode with  $LPREC = 1$ . The M68000 core is not specified to operate at this frequency, but the rest of the IMP is. In this configuration, the user does not divide the clock internally using the  $LPD4-LPCD0$  bits in the system control register.
3.  $LPREC = 0$ . Divider = 2.
4.  $LPREC = 1$ . Divider = 1024.

## DC ELECTRICAL CHARACTERISTICS

Characteristic	Symbol	Min	Max	Unit
Input High Voltage (Except EXTAL)	$V_{IH}$	2.0	$V_{DD}$	V
Input Low Voltage (Except EXTAL)	$V_{IL}$	$V_{SS} - 0.3$	0.8	V
Input High Voltage (EXTAL)	$V_{CIH}$	4.0	$V_{DD}$	V
Input Low Voltage (EXTAL)	$V_{CIL}$	$V_{SS} - 0.3$	0.6	V
Input Leakage Current	$I_{IN}$	—	20	$\mu A$
Input Capacitance All Pins	$C_{IN}$	—	15	pF
Three-State Leakage Current (2.4/0.5 V)	$I_{TSI}$	—	20	$\mu A$
Open Drain Leakage Current (2.4 V)	$I_{OD}$	—	20	$\mu A$
Output High Voltage ( $I_{OH} = 400 \mu A$ )	$V_{OH}$	$V_{DD} - 1.0$	—	V
Output Low Voltage ( $I_{OL} = 3.2 \text{ mA}$ ) $A1-A23, PB0-PB11, FC0-FC3, \overline{CS0}-\overline{CS3}$ $IAC, AVEC, BG, RCLK1, RCLK2, RCLK3,$ $TCLK1, TCLK2, TCLK3, \overline{RTS1}, \overline{RTS2}, \overline{RTS3},$ $\overline{SDS2}, PA12, RXD2, RXD3, \overline{CTS2}, \overline{CD2}, \overline{CD3}$ $\overline{DREQ}$	$V_{OL}$	—	0.5	V
( $I_{OL} = 5.3 \text{ mA}$ ) $\overline{AS}, \overline{UDS}, \overline{LDS}, R/\overline{W}, \overline{BERR},$ $\overline{BGACK}, \overline{BCLR}, \overline{DTACK}, \overline{DACK}, \overline{RMC},$ $\overline{RMC}, D0-D15, \overline{RESET}$		—	0.5	
( $I_{OL} = 7.0 \text{ mA}$ ) $\overline{TXD1}, \overline{TXD2}, \overline{TXD3}$		—	0.5	
( $I_{OL} = 8.9 \text{ mA}$ ) $\overline{BR}, \overline{DONE}, \overline{HALT}, (\overline{BR} \text{ as output})$		—	0.5	
( $I_{OL} = 3.2 \text{ mA}$ ) $\overline{CLKO}$		—	0.4	
Output Drive $\overline{CLKO}$	$O_{CLK}$	—	50	pF
Output Drive ISDN I/F (GCI Mode)	$O_{GCI}$	—	150	pF
Output Drive All Other Pins	$O_{ALL}$	—	130	pF

4

## DC ELECTRICAL CHARACTERISTICS — NMSI1 IN IDL MODE

Characteristic	Symbol	Min	Nom	Max	Unit	Condition
Power	$V_{DD}$	4.5	5.0	5.5	V	
Common	$V_{SS}$	0	0	0	V	
Temperature	T	0	25	70	$^{\circ}C$	Operating Range
<b>Input Pin Characteristics: L1CLK, L1SY1, L1RXD, L1GR</b>						
Input Low Level Voltage	$V_{IL}$	-10%		+20%	V	(% of $V_{DD}$ )
Input High Level Voltage	$V_{IH}$	$V_{DD} - 20\%$		$V_{DD} + 10\%$	V	
Input Low Level Current	$I_{IH}$	—		$\pm 10$	$\mu A$	$V_{in} = V_{SS}$
Input High Level Current	$I_{IH}$	—		$\pm 10$	$\mu A$	$V_{in} = V_{DD}$
<b>Output Pin Characteristics: L1TXD, SDS1-SDS2, L1RQ</b>						
Output Low Level Voltage	$V_{OL}$	0		0.50	V	$I_{OL} = 2.0 \text{ mA}$
Output High Level Voltage	$V_{OH}$	$V_{DD} - 0.5$		$V_{DD}$	V	$I_{OH} = 2.0 \text{ mA}$

# AC ELECTRICAL SPECIFICATIONS — CLOCK TIMING

(see Figure 6)

Num.	Characteristic	Symbol	16.67 MHz		Unit
			Min	Max	
	Frequency of Operation	f	8	16.67	MHz
1	Clock Period (EXTAL)	$t_{cyc}$	60	125	ns
2, 3	Clock Pulse Width (EXTAL)	$t_{CL}, t_{CH}$	25	62.5	ns
4, 5	Clock Rise and Fall Times (EXTAL)	$t_{Cr}, t_{Cf}$	—	5	ns
5a	EXTAL to CLKO Delay (See Notes 1 and 2)	$t_{CD}$	2	11	ns

**NOTE:**

1. CLKO loading is 50 pF max.
2. CLKO skew from the rising and falling edges of EXTAL will not differ from each other by more than 1 ns, if the EXTAL rise time equals the EXTAL fall time.

4

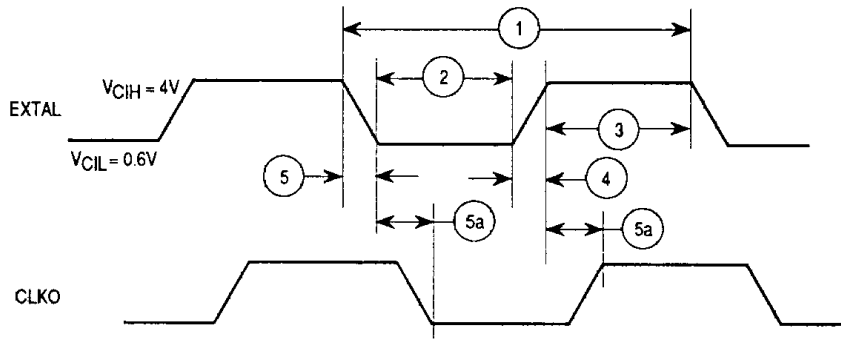

Figure 6. Clock Timing Diagram

# AC ELECTRICAL SPECIFICATIONS — IMP BUS MASTER CYCLES

(see Figures 7, 8, and 9)

Num.	Characteristic	Symbol	16.67 MHz		Unit
			Min	Max	
6	Clock High to FC, Address Valid	t <sub>CHFCADV</sub>	—	45	ns
7	Clock High to Address, Data Bus High Impedance (Maximum)	t <sub>CHADZ</sub>	—	50	ns
8	Clock High to Address, FC Invalid (Minimum)	t <sub>CHAFI</sub>	0	—	ns
9	Clock High to $\overline{AS}$ , $\overline{DS}$ Asserted (see Note 1)	t <sub>CHSL</sub>	3	30	ns
11	Address, FC Valid to $\overline{AS}$ , $\overline{DS}$ Asserted (Read) $\overline{AS}$ Asserted (Write) (see Note 2)	t <sub>AFCVSL</sub>	15	—	ns
12	Clock Low to $\overline{AS}$ , $\overline{DS}$ Negated (see Note 1)	t <sub>CLSH</sub>	—	30	ns
13	$\overline{AS}$ , $\overline{DS}$ Negated to Address, FC Invalid (see Note 2)	t <sub>SHAFI</sub>	15	—	ns
14	$\overline{AS}$ (and $\overline{DS}$ Read) Width Asserted (see Note 2)	t <sub>SL</sub>	120	—	ns
14A	$\overline{DS}$ Width Asserted, Write (see Note 2)	t <sub>DSL</sub>	60	—	ns
15	$\overline{AS}$ , $\overline{DS}$ Width Negated (see Note 2)	t <sub>SH</sub>	60	—	ns
16	Clock High to Control Bus High Impedance	t <sub>CHCZ</sub>	—	50	ns
17	$\overline{AS}$ , $\overline{DS}$ Negated to R/ $\overline{W}$ Invalid (see Note 2)	t <sub>SHRH</sub>	15	—	ns
18	Clock High to R/ $\overline{W}$ High (see Note 1)	t <sub>CHRH</sub>	—	30	ns
20	Clock High to R/ $\overline{W}$ Low (see Note 1)	t <sub>CHRL</sub>	—	30	ns
20A	$\overline{AS}$ Asserted to R/ $\overline{W}$ Low (Write) (see Notes 2 and 6)	t <sub>ASRV</sub>	—	10	ns
21	Address FC Valid to R/ $\overline{W}$ Low (Write) (see Note 2)	t <sub>AFCVRL</sub>	15	—	ns
22	R/ $\overline{W}$ Low to $\overline{DS}$ Asserted (Write) (see Note 2)	t <sub>RLSL</sub>	30	—	ns
23	Clock Low to Data-Out Valid	t <sub>CLDO</sub>	—	30	ns
25	$\overline{AS}$ , $\overline{DS}$ , Negated to Data-Out Invalid (Write) (see Note 2)	t <sub>SHDOI</sub>	15	—	ns
26	Data-Out Valid to $\overline{DS}$ Asserted (Write) (see Note 2)	t <sub>DOSL</sub>	15	—	ns
27	Data-In Valid to Clock Low (Setup Time on Read) (see Note 5)	t <sub>DICL</sub>	7	—	ns
28	$\overline{AS}$ , $\overline{DS}$ Negated to $\overline{DTACK}$ Negated (Asynchronous Hold) (see Note 2)	t <sub>SHDAH</sub>	0	110	ns
29	$\overline{AS}$ , $\overline{DS}$ Negated to Data-In Invalid (Hold Time on Read)	t <sub>SHDII</sub>	0	—	ns
30	$\overline{AS}$ , $\overline{DS}$ Negated to $\overline{BERR}$ Negated	t <sub>SHBEH</sub>	0	—	ns
31	$\overline{DTACK}$ Asserted to Data-In Valid (Setup Time) (see Notes 2 and 5)	t <sub>DALDI</sub>	—	50	ns
32	$\overline{HALT}$ and $\overline{RESET}$ Input Transition Time	t <sub>RRH</sub> , t <sub>RHF</sub>	—	150	ns
33	Clock High to $\overline{BG}$ Asserted	t <sub>CHGL</sub>	—	30	ns
34	Clock High to $\overline{BG}$ Negated	t <sub>CHGH</sub>	—	30	ns
35	$\overline{BR}$ Asserted to $\overline{BG}$ Asserted	t <sub>BRLGL</sub>	2.5	4.5	clks
36	$\overline{BR}$ Negated to $\overline{BG}$ Negated (see Note 7)	t <sub>BRHGH</sub>	1.5	2.5	clks
37	$\overline{BGACK}$ Asserted to $\overline{BG}$ Negated	t <sub>GALGH</sub>	2.5	4.5	clks
37A	$\overline{BGACK}$ Asserted to $\overline{BR}$ Negated (see Note 8)	t <sub>GALBRH</sub>	10	1.5	ns:clks
38	$\overline{BG}$ Asserted to Control, Address, Data Bus High Impedance ( $\overline{AS}$ Negated)	t <sub>GLZ</sub>	—	50	ns
39	$\overline{BG}$ Width Negated	t <sub>GH</sub>	1.5	—	clks
44	$\overline{AS}$ , $\overline{DS}$ Negated to $\overline{AVEC}$ Negated	t <sub>SHVPH</sub>	0	50	ns
46	$\overline{BGACK}$ Width Low	t <sub>GAL</sub>	1.5	—	clks
47	Asynchronous Input Setup Time (see Note 5)	t <sub>ASI</sub>	10	—	ns

—Continued

4

## AC ELECTRICAL SPECIFICATIONS — IMP BUS MASTER CYCLES

(Continued) (see Figures 7, 8, and 9)

Num.	Characteristic	Symbol	16.67 MHz		Unit
			Min	Max	
48	$\overline{\text{BERR}}$ Asserted to $\overline{\text{DTACK}}$ Asserted (see Notes 2 and 3)	$t_{\text{BELDAL}}$	10	—	ns
53	Data-Out Hold from Clock High	$t_{\text{CHDOI}}$	0	—	ns
55	$\text{R}/\overline{\text{W}}$ Asserted to Data Bus Impedance Change	$t_{\text{RLDBD}}$	0	—	ns
56	$\overline{\text{HALT}}/\overline{\text{RESET}}$ Pulse Width (see Note 4)	$t_{\text{HRPW}}$	10	—	clks
57	$\overline{\text{BGACK}}$ Negated to $\overline{\text{AS}}$ , $\overline{\text{DS}}$ , $\text{R}/\overline{\text{W}}$ Driven	$t_{\text{GASD}}$	1.5	—	clks
57A	$\overline{\text{BGACK}}$ Negated to FC	$t_{\text{GAFD}}$	1	—	clks
58	$\overline{\text{BR}}$ Negated to $\overline{\text{AS}}$ , $\overline{\text{DS}}$ , $\text{R}/\overline{\text{W}}$ Driven (see Note 7)	$t_{\text{RHSD}}$	1.5	—	clks
58A	$\overline{\text{BR}}$ Negated to FC (see Note 7)	$t_{\text{RHFD}}$	1	—	clks
60	Clock High to $\overline{\text{BCLR}}$ Asserted	$t_{\text{CHBCL}}$	—	30	ns
61	Clock High to $\overline{\text{BCLR}}$ Negated (See Note 10)	$t_{\text{CHBCH}}$	—	30	ns
62	Clock Low (S0 Falling Edge during read) to $\overline{\text{RMC}}$ Asserted	$t_{\text{CLRML}}$	—	30	ns
63	Clock High (S7 Rising Edge during write) to $\overline{\text{RMC}}$ Negated	$t_{\text{CHRMH}}$	—	30	ns
64	$\overline{\text{RMC}}$ Negated to $\overline{\text{BG}}$ Asserted (see Note 9)	$t_{\text{RMHGL}}$	—	30	ns

### NOTES:

- For loading capacitance of less than or equal to 50 picofarads, subtract 4 nanoseconds from the value given in the maximum columns.
- Actual value depends on clock period.
- If #47 is satisfied for both  $\overline{\text{DTACK}}$  and  $\overline{\text{BERR}}$ , #48 may be ignored. In the absence of  $\overline{\text{DTACK}}$ ,  $\overline{\text{BERR}}$  is a synchronous input using the asynchronous input setup time (#47).
- For powerup, the MC68302 must be held in the reset state for 100 milliseconds to allow stabilization of on-chip circuit. After the system is powered up #56 refers to the minimum pulse width required to reset the processor.
- If the asynchronous input setup (#47) requirement is satisfied for  $\overline{\text{DTACK}}$ , the  $\overline{\text{DTACK}}$  asserted to data setup time (#31) requirement can be ignored. The data must only satisfy the data-in to clock low setup time (#27) for the following clock cycle.
- When  $\overline{\text{AS}}$  and  $\text{R}/\overline{\text{W}}$  are equally loaded ( $\pm 20\%$ ), subtract 5 nanoseconds from the values given in these columns.
- The MC68302 will negate  $\overline{\text{BG}}$  and begin driving the bus if external arbitration logic negates  $\overline{\text{BR}}$  before asserting  $\overline{\text{BGACK}}$ .
- The minimum value must be met to guarantee proper operation. If the maximum value is exceeded,  $\overline{\text{BG}}$  may be reasserted.
- This specification is valid only when the RMCST bit is set in the SCR register.
- Occurs on S0 of SDMA read/write access when the SDMA becomes bus master.



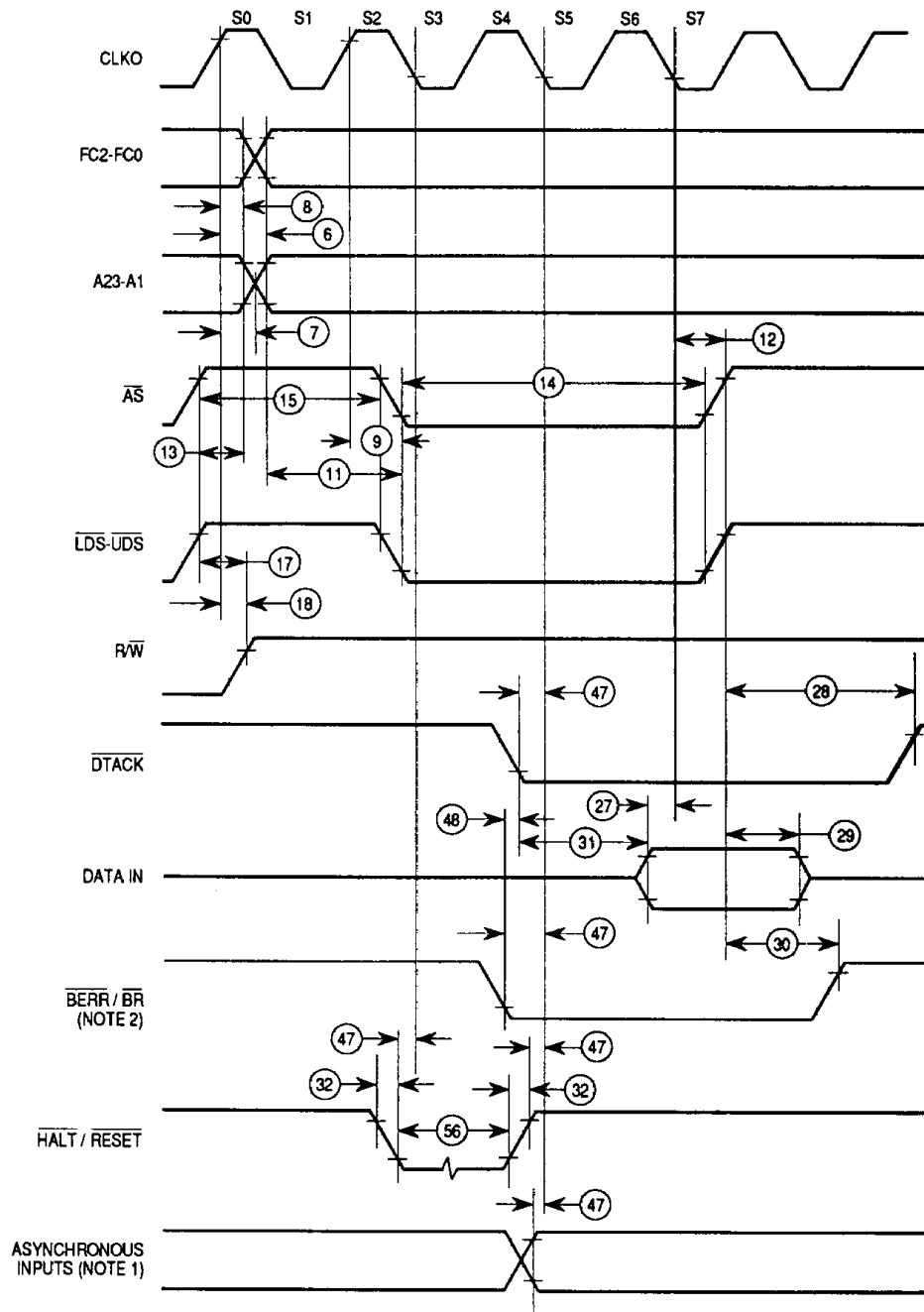

NOTES:

1. Setup time for the asynchronous inputs  $\overline{IPL2}$ - $\overline{IPL0}$  guarantees their recognition at the next falling edge of the clock.
2.  $\overline{BR}$  need fall at this time only to ensure being recognized at the end of the bus cycle.
3. Timing measurements are referenced to and from a low voltage of 0.8 V and a high voltage of 2.0 V, unless otherwise noted. The voltage swing through this range should start outside and pass through the range such that the rise or fall is linear between 0.8 V and 2.0 V.

Figure 7. Read Cycle Timing Diagram

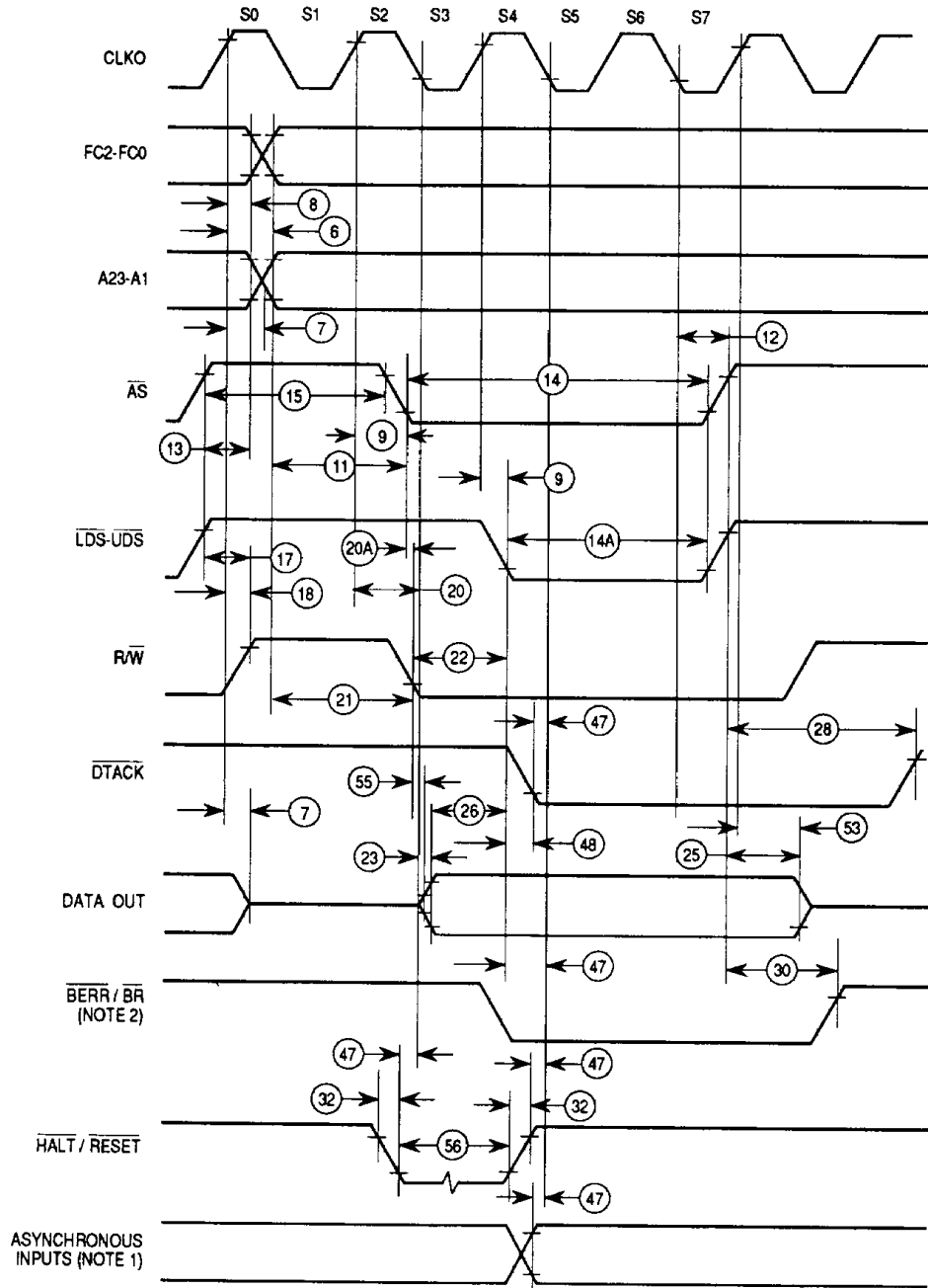

NOTES:

1. Timing measurements are referenced to and from a low voltage of 0.8 V and a high voltage of 2.0 V, unless otherwise noted. The voltage swing through this range should start outside and pass through the range such that the rise or fall is linear between 0.8 V and 2.0 V.
2. Because of loading variations, R/W may be valid after AS even though both are initiated by the rising edge of S2 (specification #20A).

Figure 8. Write Cycle Timing Diagram

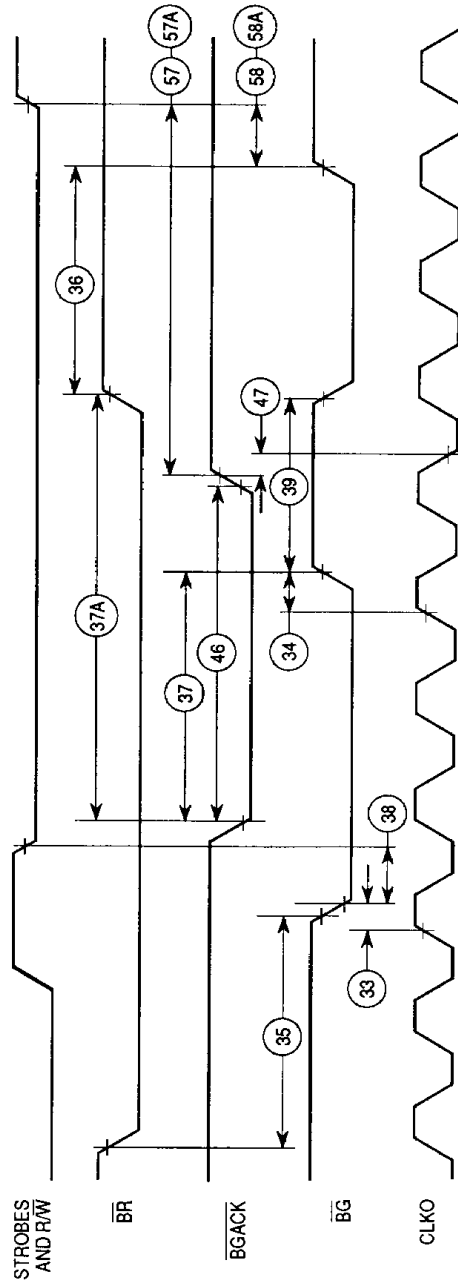

NOTE: Setup time to the clock (#47) for the asynchronous inputs  $\overline{BERR}$ ,  $\overline{BGACK}$ ,  $\overline{BR}$ ,  $\overline{DTACK}$ , and  $\overline{IPL2-IPL0}$  guarantees their recognition at the next falling edge of the clock.

Figure 9. Bus Arbitration Timing Diagram

## AC ELECTRICAL SPECIFICATIONS — DMA

(see Figure 10)

Num.	Characteristic	Symbol	16.67 MHz		Unit
			Min	Max	
80	$\overline{DREQ}$ Asynchronous Setup Time (see Note 1)	tREQASI	15	—	ns
81	$\overline{DREQ}$ Width Low (see Note 2)	tREQL	2	—	clk
82	$\overline{DREQ}$ Low to $\overline{BR}$ Low (see Notes 3 and 4)	tREQLBRL	—	2	clk
83	Clock High to $\overline{BR}$ Low (see Notes 3 and 4)	tCHBRL	—	30	ns
84	Clock High to $\overline{BR}$ High Impedance (see Notes 3 and 4)	tCHBRZ	—	30	ns
85	$\overline{BGACK}$ Low to $\overline{BR}$ High Impedance (see Notes 3 and 4)	tBKLBZ	30	—	ns
86	Clock High to $\overline{BGACK}$ Low	tCHBKL	—	30	ns
87	$\overline{AS}$ and $\overline{BGACK}$ High (the latest one) to $\overline{BGACK}$ Low (when $\overline{BG}$ is Asserted)	tABHBKL	1.5	2.5 +30	clk ns
88	$\overline{BG}$ Low to $\overline{BGACK}$ Low (No Other Bus Master) (see Notes 3 and 4)	tBGLBKL	1.5	2.5 +30	clk ns
89	$\overline{BR}$ High Impedance to $\overline{BG}$ High (see Notes 3 and 4)	tBRHBGH	0	—	ns
90	Clock on Which $\overline{BGACK}$ Low to Clock on Which $\overline{AS}$ Low	tCLBKAL	2	2	clk
91	Clock High to $\overline{BGACK}$ High	tCHBKH	—	30	ns
92	Clock Low to $\overline{BGACK}$ High Impedance	tCLBKZ	—	15	ns
93	Clock High to $\overline{DACK}$ Low	tCHACKL	—	30	ns
94	Clock Low to $\overline{DACK}$ High	tCLACKH	—	30	ns
95	Clock High to $\overline{DONE}$ Low (Output)	tCHDNL	—	30	ns
96	Clock Low to $\overline{DONE}$ High Impedance	tCLDNZ	—	30	ns
97	$\overline{DONE}$ Input Low to Clock High (Asynchronous Setup)	tDNLCH	15	—	ns

### NOTES:

1.  $\overline{DREQ}$  is sampled on the falling edge of CLK in cycle steal and burst modes.
2. If #80 is satisfied for  $\overline{DREQ}$ , #81 may be ignored.
3.  $\overline{BR}$  will not be asserted while  $\overline{AS}$ , HALT, or BERR is asserted.
4. Specifications are for DISABLE CPU mode only.
5.  $\overline{DREQ}$ ,  $\overline{DACK}$ , and  $\overline{DONE}$  do not apply to the SDMA channels.
6. IDMA and SDMA read and write cycle timing is the same as that for the M68000 core.

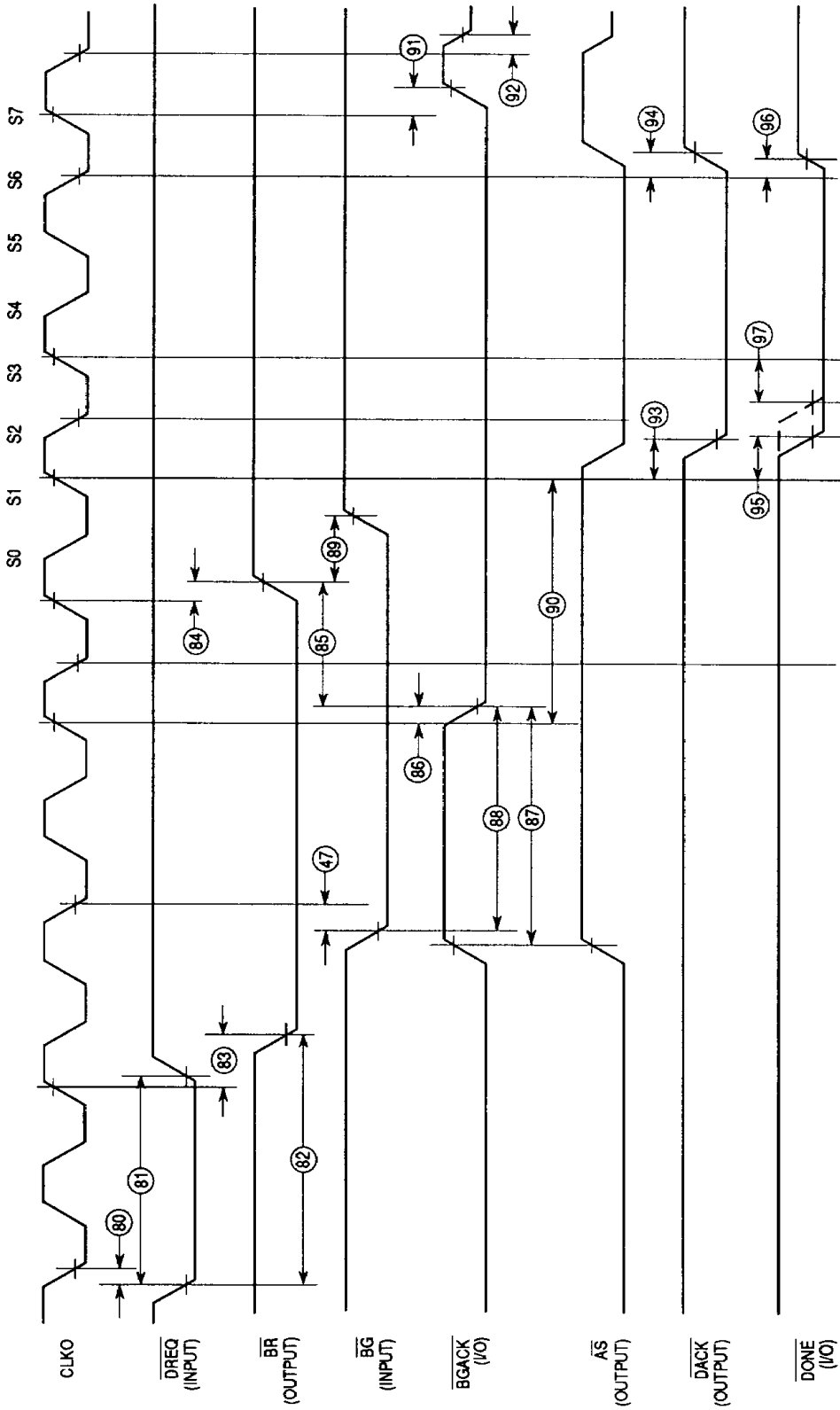

Figure 10. DMA Timing Diagram

## AC ELECTRICAL SPECIFICATIONS — EXTERNAL MASTER INTERNAL ASYNCHRONOUS READ/WRITE CYCLES (see Figures 11 and 12)

Num.	Characteristic	Symbol	16.67 MHz		Unit
			Min	Max	
100	$\overline{R\overline{W}}$ Valid to $\overline{DS}$ Low	$t_{RWVDSL}$	0	—	ns
101	$\overline{DS}$ Low to Data In Valid	$t_{DSLIV}$	—	30	ns
102	$\overline{DTACK}$ Low to Data In Hold Time	$t_{DKLDH}$	0	—	ns
103	$\overline{AS}$ Valid to $\overline{DS}$ Low	$t_{ASVDSL}$	0	—	ns
104	$\overline{DTACK}$ Low to $\overline{DS}$ High	$t_{DKLDSH}$	0	—	ns
105	$\overline{DS}$ High to $\overline{DTACK}$ High	$t_{DSHDKH}$	—	45	ns
106	$\overline{DS}$ Inactive to $\overline{AS}$ Inactive	$t_{DSIASI}$	0	—	ns
107	$\overline{DS}$ High to $\overline{R\overline{W}}$ High	$t_{DSHRWH}$	0	—	ns
108	$\overline{DS}$ High to Data High Impedance	$t_{DSHDZ}$	—	45	ns
108A	$\overline{DS}$ High to Data Out Hold Time	$t_{DSHDH}$	0	—	ns
109	$\overline{DS}$ High to Data In Hold Time (see Note)	$t_{DSHDOH}$	0	—	ns
109A	Data Out Valid to $\overline{DTACK}$ Low	$t_{DOVDKL}$	15	—	ns

NOTE: If  $\overline{AS}$  is negated before  $\overline{DS}$ , the data bus could be three-stated (spec 126) before  $\overline{DS}$  is negated.

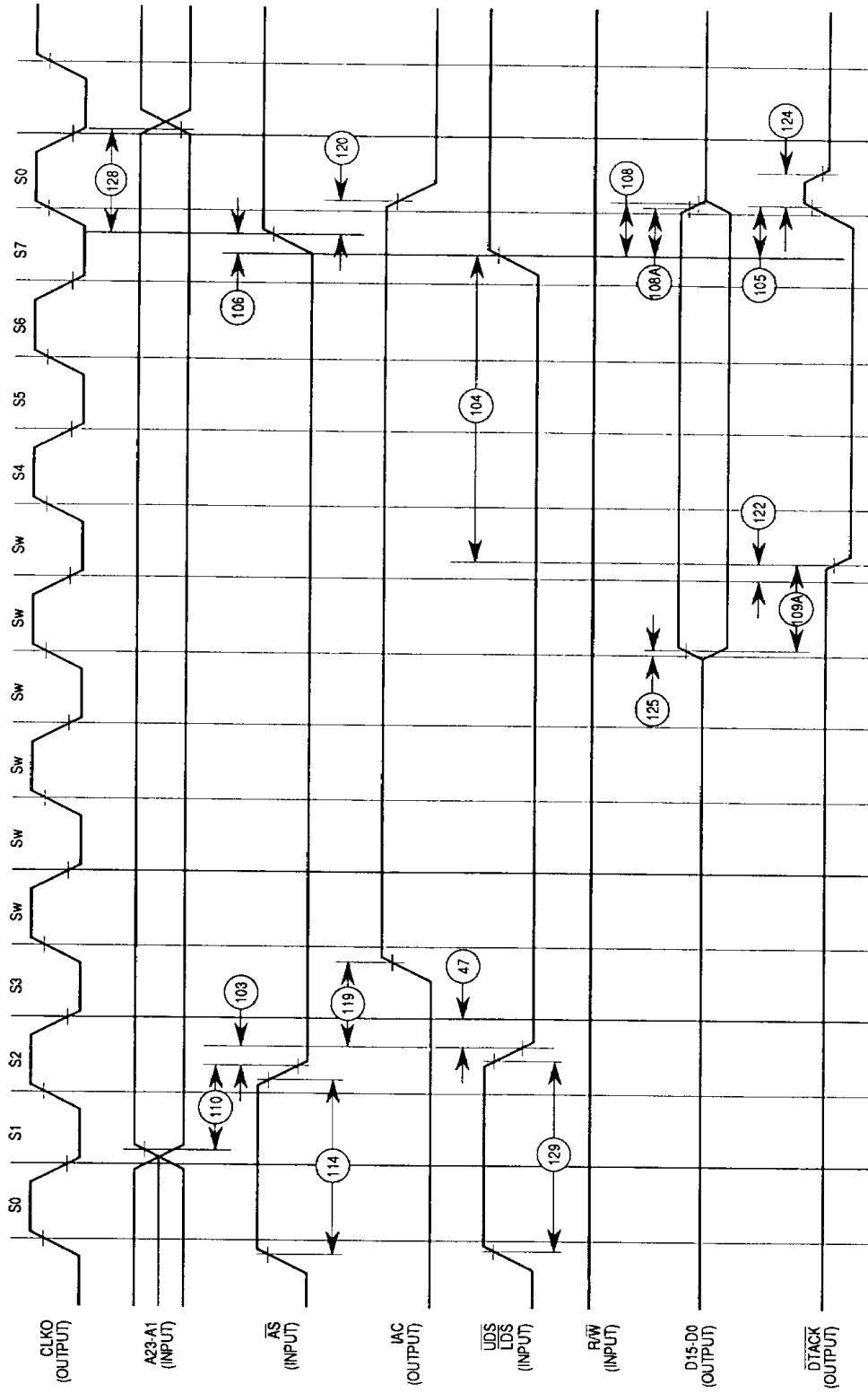

Figure 11. External Master Internal Asynchronous Read Cycle Timing Diagram

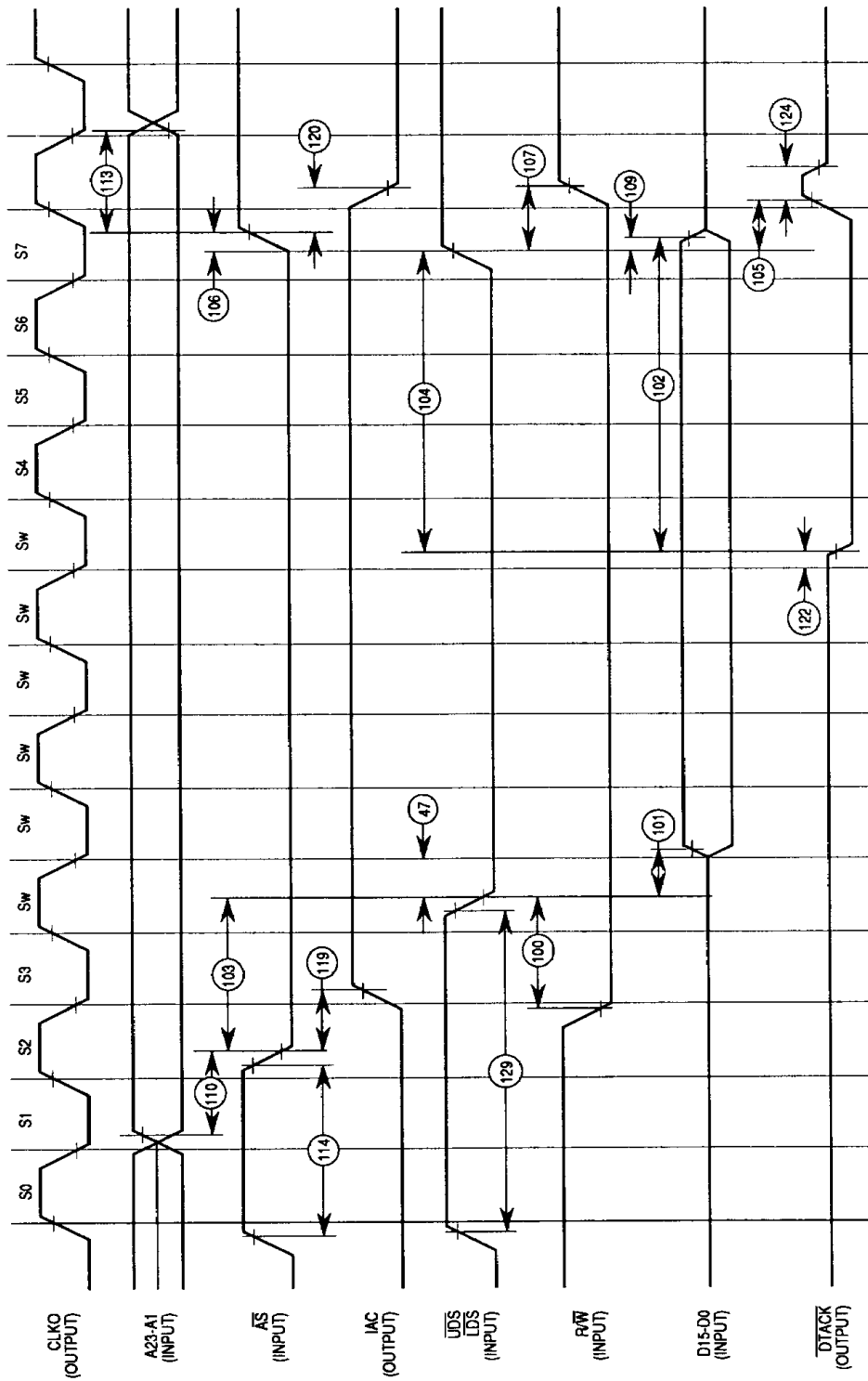

Figure 12. External Master Internal Asynchronous Write Cycle Timing Diagram



## AC ELECTRICAL SPECIFICATIONS — EXTERNAL MASTER INTERNAL SYNCHRONOUS READ/WRITE CYCLES (see Figures 13, 14, and 15)

Num.	Characteristic	Symbol	16.67 MHz		Unit
			Min	Max	
110	Address Valid to $\overline{AS}$ Low	$t_{AVASL}$	15	—	ns
111	$\overline{AS}$ Low to Clock High	$t_{ASLCH}$	30	—	ns
112	Clock Low to $\overline{AS}$ High	$t_{CLASH}$	—	45	ns
113	$\overline{AS}$ High to Address Hold Time on Write	$t_{ASHAH}$	0	—	ns
114	$\overline{AS}$ Inactive Time	$t_{ASH}$	1	—	clk
115	$\overline{UDS}/\overline{LDS}$ Low to Clock High	$t_{SLCH}$	40	—	ns
116	Clock Low to $\overline{UDS}/\overline{LDS}$ High	$t_{CLSH}$	—	45	ns
117	R/ $\overline{W}$ Valid to Clock High	$t_{RWVCH}$	30	—	ns
118	Clock High to R/ $\overline{W}$ High	$t_{CHRWH}$	—	45	ns
119	$\overline{AS}$ Low to IAC High	$t_{ASLIAH}$	—	40	ns
120	$\overline{AS}$ High to IAC Low	$t_{ASHIAL}$	—	40	ns
121	$\overline{AS}$ Low to $\overline{DTACK}$ Low (0 Wait State)	$t_{ASLDTL}$	—	45	ns
122	Clock Low to $\overline{DTACK}$ Low (1 Wait State)	$t_{CLDTL}$	—	30	ns
123	$\overline{AS}$ High to $\overline{DTACK}$ High	$t_{ASHDTH}$	—	45	ns
124	$\overline{DTACK}$ High to $\overline{DTACK}$ High Impedance	$t_{DTHTZ}$	—	15	ns
125	Clock High to Data Out Valid	$t_{CHDOV}$	—	30	ns
126	$\overline{AS}$ High to Data High Impedance	$t_{ASHDZ}$	—	45	ns
127	$\overline{AS}$ High to Data Out Hold Time	$t_{ASHDOI}$	0	—	ns
128	$\overline{AS}$ High to Address Hold Time on Read	$t_{ASHAI}$	0	—	ns
129	$\overline{UDS}/\overline{LDS}$ Inactive Time	$t_{SH}$	1	—	clk
130	Data In Valid to Clock Low	$t_{CLDIV}$	30	—	ns
131	Clock Low to Data In Hold Time	$t_{CLDIH}$	15	—	ns

NOTE: Specifications are valid only when SAM = 1 in the SCR.

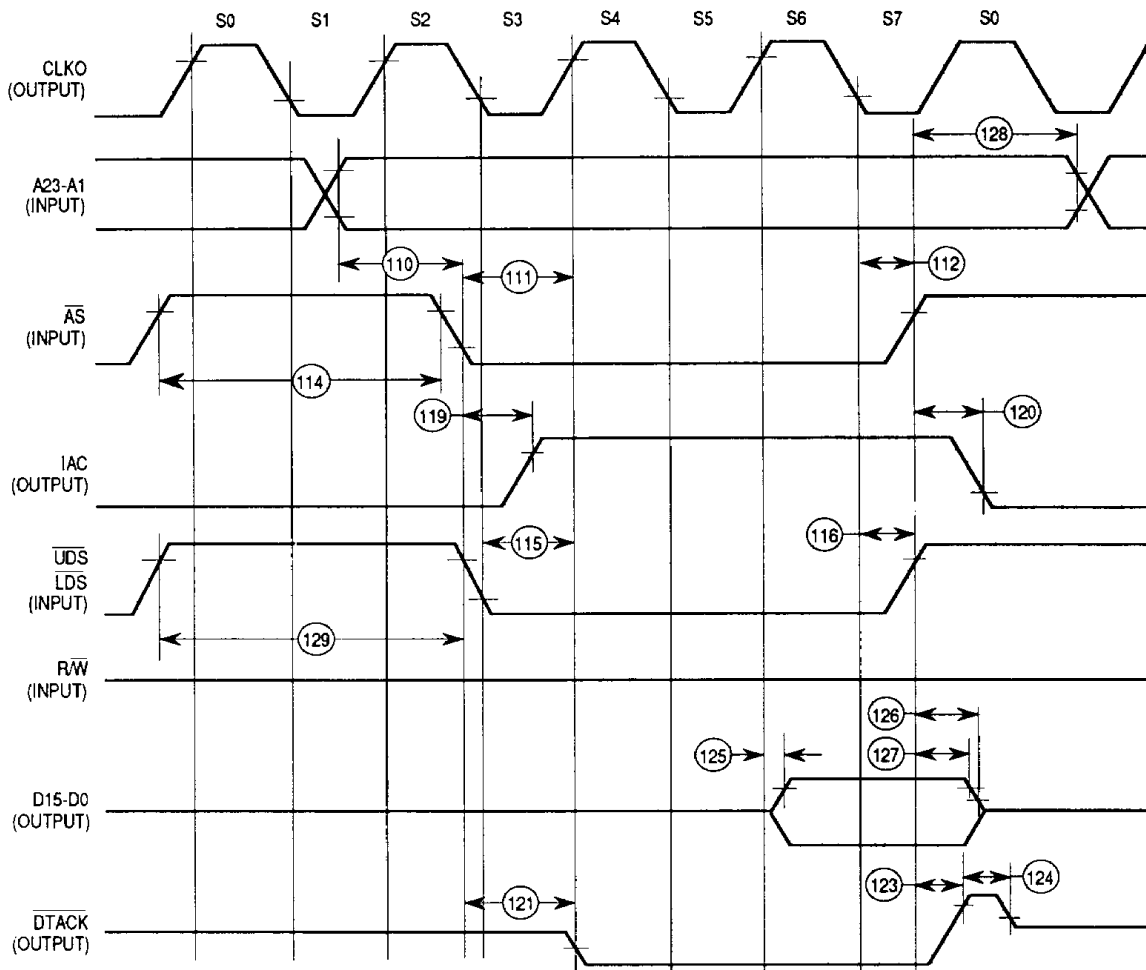
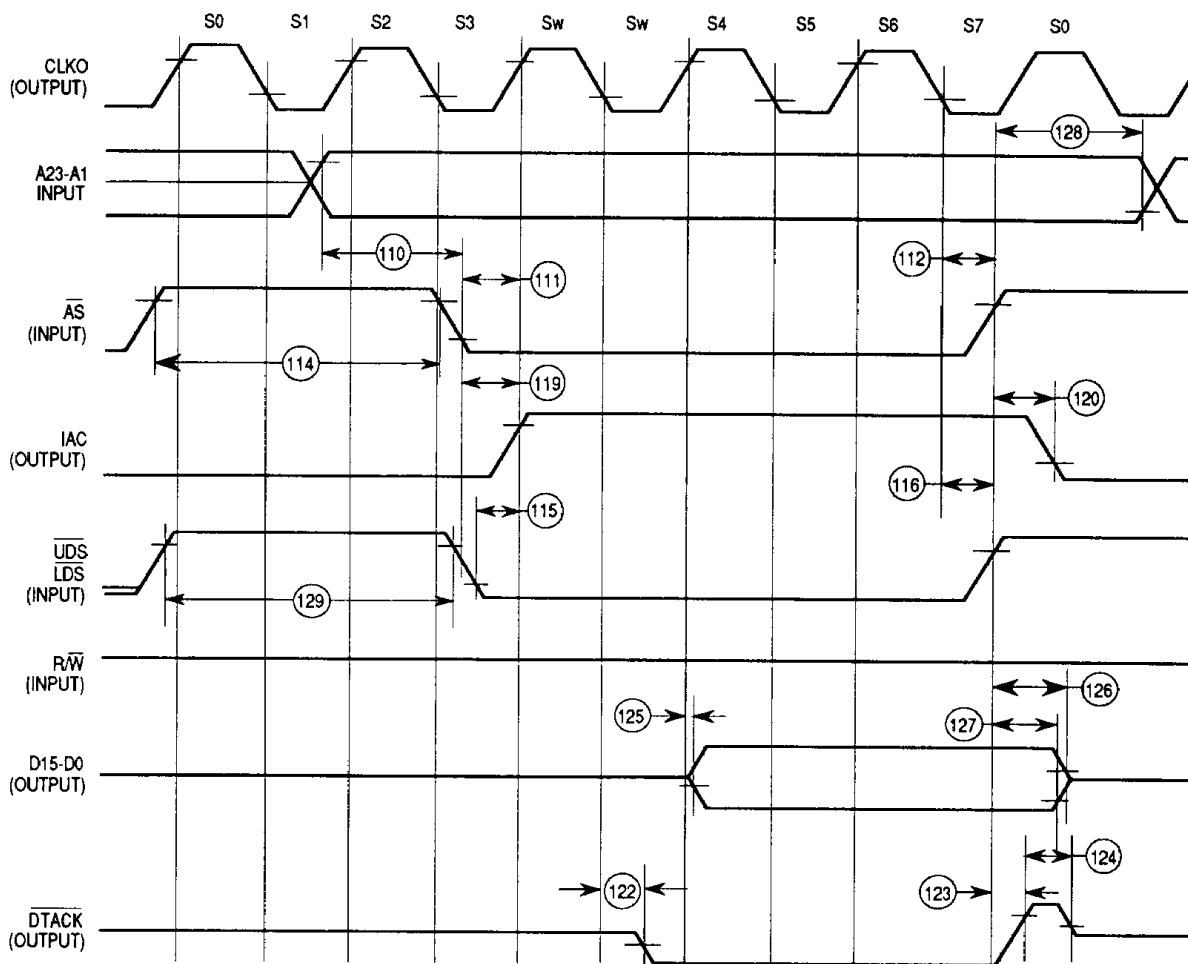

Figure 13. External Master Internal Synchronous Read Cycle Timing Diagram



4

Figure 14. External Master Internal Synchronous Read Cycle Timing Diagram (One Wait State)

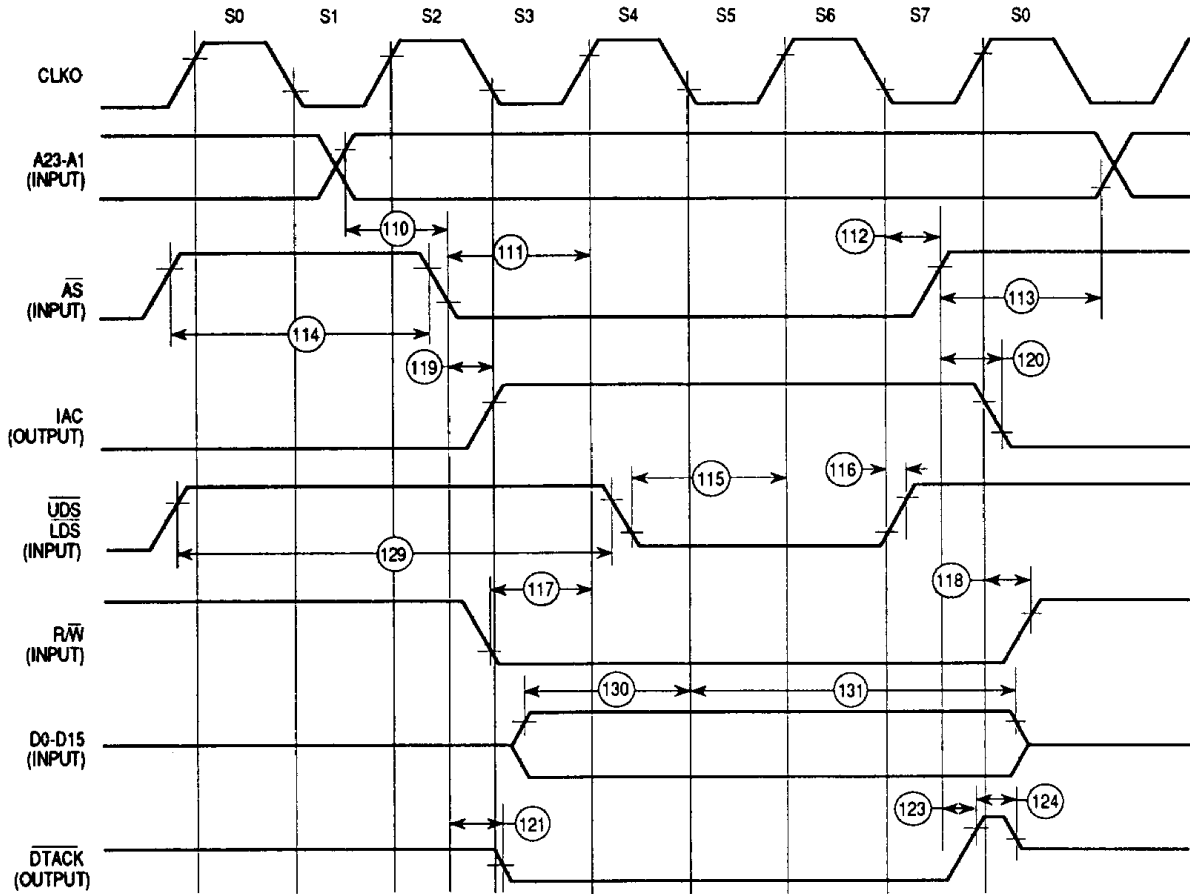
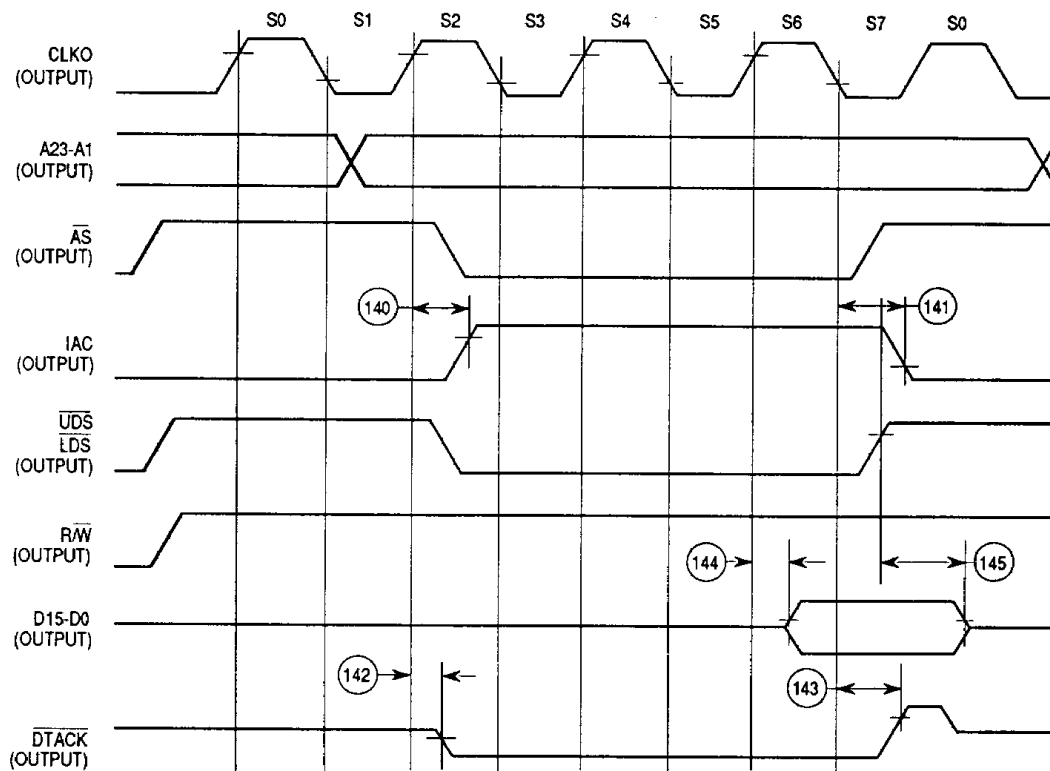

Figure 15. External Master Internal Synchronous Write Cycle Timing Diagram

# AC ELECTRICAL SPECIFICATIONS — INTERNAL MASTER INTERNAL READ/WRITE CYCLES (see Figure 16)

Num.	Characteristic	Symbol	16.67 MHz		Unit
			Min	Max	
140	Clock High to IAC High	$t_{CHIAH}$	—	40	ns
141	Clock Low to IAC Low	$t_{CLIAL}$	—	40	ns
142	Clock High to $\overline{DTACK}$ Low (0 Wait State)	$t_{CHDTL}$	—	45	ns
143	Clock Low to $\overline{DTACK}$ High	$t_{CLDTH}$	—	40	ns
144	Clock High to Data Out Valid	$t_{CHDOV}$	—	30	ns
145	$\overline{AS}$ High to Data Out Hold Time	$t_{ASHDOH}$	0	—	ns



4

Figure 16. Internal Master Internal Read Cycle Timing Diagram

## AC ELECTRICAL SPECIFICATIONS — CHIP-SELECT TIMING INTERNAL MASTER (see Figure 17)

Num.	Characteristic	Symbol	16.67 MHz		Unit
			Min	Max	
150	Clock High to $\overline{CS}$ , $\overline{IACK}$ Low (see Note 2)	$t_{CHCSIAKL}$	—	40	ns
151	Clock Low to $\overline{CS}$ , $\overline{IACK}$ High (see Note 2)	$t_{CLCSIAKH}$	—	40	ns
152	$\overline{CS}$ Width Negated	$t_{CSH}$	60	—	ns
153	Clock High to $\overline{DTACK}$ Low (0 Wait State)	$t_{CHDTKL}$	—	45	ns
154	Clock Low to $\overline{DTACK}$ Low (1–6 Wait States)	$t_{CLDTKL}$	—	30	ns
155	Clock Low to $\overline{DTACK}$ High	$t_{CLDTKH}$	—	40	ns
156	Clock High to $\overline{BERR}$ Low (see Note 1)	$t_{CHBERL}$	—	40	ns
157	Clock Low to $\overline{BERR}$ High Impedance (see Note 1)	$t_{CLBERH}$	—	40	ns
158	$\overline{DTACK}$ High to $\overline{DTACK}$ High Impedance	$t_{DTKHDTKZ}$	—	15	ns
171	Input Data Hold Time from S6 Low	$t_{IDHCL}$	5	—	ns
172	$\overline{CS}$ Negated to Data Out Invalid (Write)	$t_{CSNDOI}$	10	—	ns
173	Address, FC Valid to $\overline{CS}$ Asserted	$t_{AFVCSA}$	15	—	ns
174	$\overline{CS}$ Negated to Address, FC Invalid	$t_{CSNAFI}$	15	—	ns
175	$\overline{CS}$ Low Time (0 Wait States)	$t_{CSLT}$	120	—	ns
176	$\overline{CS}$ Negated to R/ $\overline{W}$ Invalid	$t_{CSNRWI}$	10	—	ns
177	$\overline{CS}$ Asserted to R/ $\overline{W}$ Low (Write)	$t_{CSARWL}$	—	10	ns
178	$\overline{CS}$ Negated to Data In Invalid (Hold Time on Read)	$t_{CSNDII}$	0	—	ns

NOTE:

1. This specification is valid only when the ADCE or WPVE bits in the SCR are set.
2. For loading capacitance less than or equal to 50 pF, subtract 4 ns from the maximum value given.
3. Specs 172–178 do not have diagrams. However, similar diagrams for  $\overline{AS}$  are shown as 25, 11, 13, 14, 17, 20A, and 29, respectively.

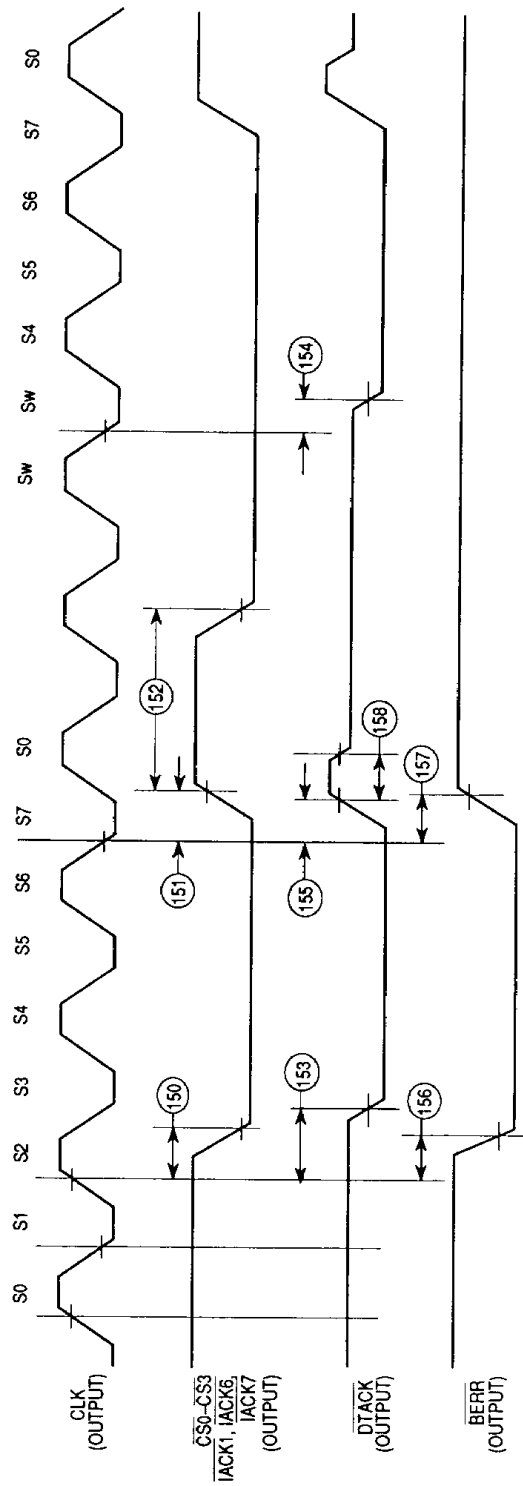

Figure 17. Internal Master Chip-Select Timing Diagram

# AC ELECTRICAL SPECIFICATIONS — CHIP-SELECT TIMING

## EXTERNAL MASTER (see Figure 18)

Num.	Characteristic	Symbol	16.67 MHz		Unit
			Min	Max	
154	Clock Low to $\overline{DTACK}$ Low (1–6 Wait States)	$t_{CLDTKL}$	—	30	ns
160	$\overline{AS}$ Low to $\overline{CS}$ Low	$t_{ASLCSL}$	—	30	ns
161	$\overline{AS}$ High to $\overline{CS}$ High	$t_{ASHCSH}$	—	30	ns
162	Address Valid to $\overline{AS}$ Low	$t_{AVASL}$	15	—	ns
163	R/W Valid to $\overline{AS}$ Low (see Note 1)	$t_{RWVASL}$	15	—	ns
164	$\overline{AS}$ Negated to Address Hold Time	$t_{ASHAI}$	0	—	ns
165	$\overline{AS}$ Low to $\overline{DTACK}$ Low (0 Wait State)	$t_{ASLDTKL}$	—	45	ns
167	$\overline{AS}$ High to $\overline{DTACK}$ High	$t_{ASHDTKH}$	—	30	ns
168	$\overline{AS}$ Low to $\overline{BERR}$ Low (see Note 2)	$t_{ASLBERL}$	—	30	ns
169	$\overline{AS}$ High to $\overline{BERR}$ High (see Notes 2 and 3)	$t_{ASHBERH}$	—	30	ns

4

NOTE:

1. The minimum value must be met to guarantee write protection operation.
2. This specification is valid when the DCE or WPVE bits in the SCR are set.
3. Also applies after a timeout of the hardware watchdog.

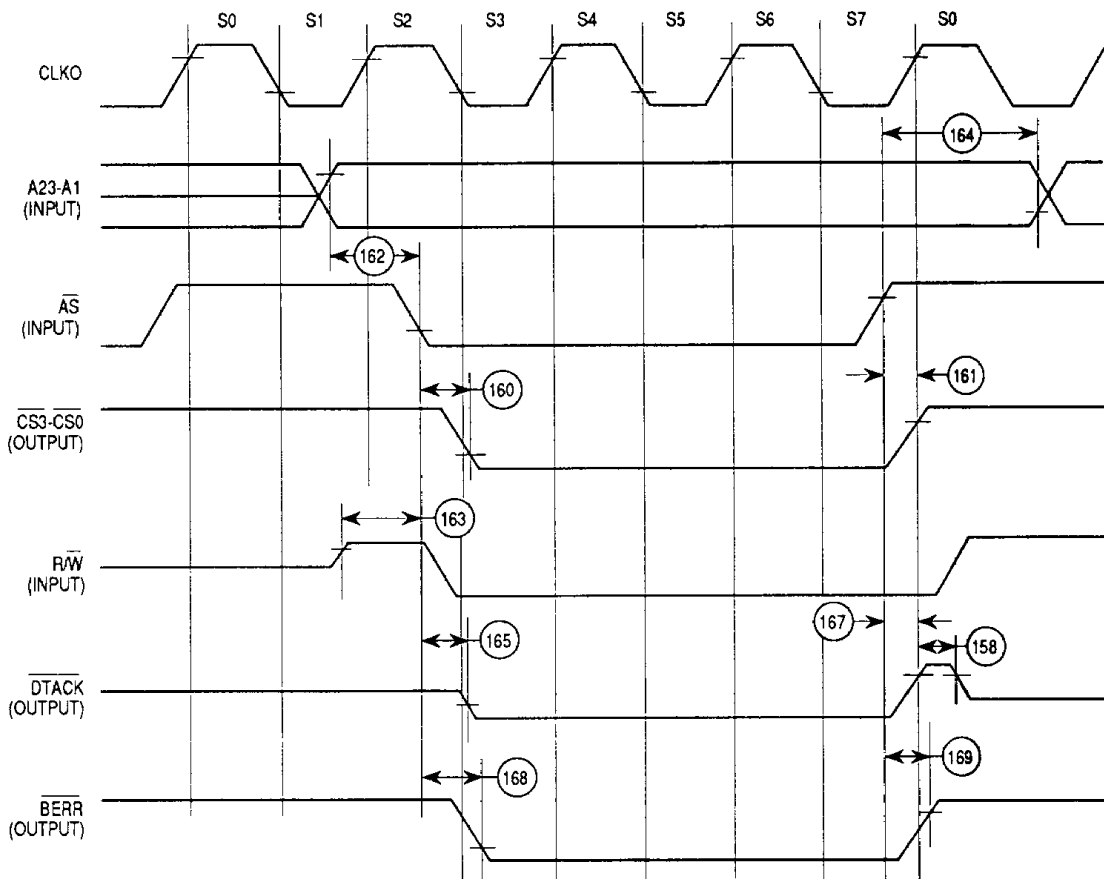

Figure 18. External Master Chip-Select Timing Diagram



# AC ELECTRICAL SPECIFICATIONS — PARALLEL I/O

(see Figure 19)

Num.	Characteristic	Symbol	16.67 MHz		Unit
			Min	Max	
180	Input Data Setup Time (to Clock Low)	$t_{DSU}$	20	—	ns
181	Input Data Hold Time (from Clock Low)	$t_{DH}$	10	—	ns
182	Clock High to Data out Valid (CPU Writes Data, Control, or Direction)	$t_{CHDOV}$	—	35	ns

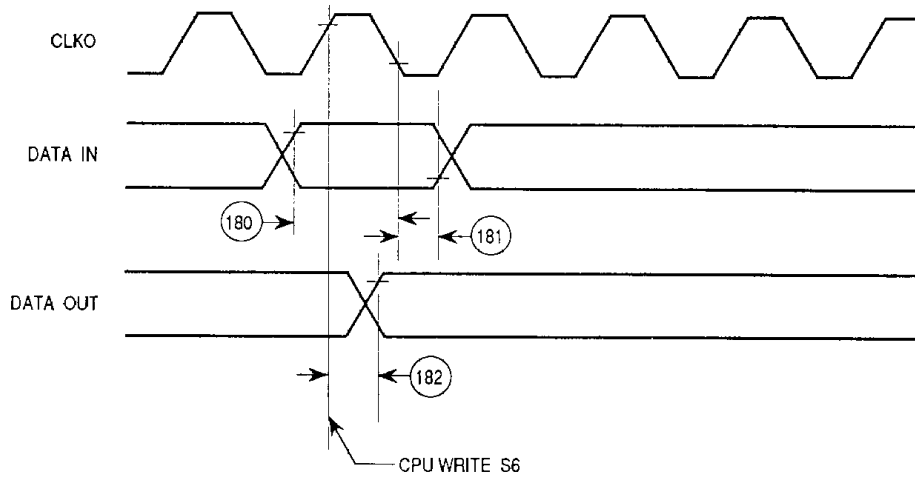

4

Figure 19. Parallel I/O Data In/Data Out Timing Diagram

## AC ELECTRICAL SPECIFICATIONS — INTERRUPTS

(see Figure 20)

Num.	Characteristic	Symbol	16.67 MHz		Unit
			Min	Max	
190	Interrupt Pulse Width Low $\overline{IRQ}$ (Edge Triggered Mode)	$t_{IPW}$	50	—	ns
191	Minimum Time Between Active Edges	$t_{AEMT}$	3	—	clk

NOTE: Setup time for the asynchronous inputs IPL2–IPL0 and  $\overline{AVEC}$  guarantees their recognition at the next falling edge of the clock.

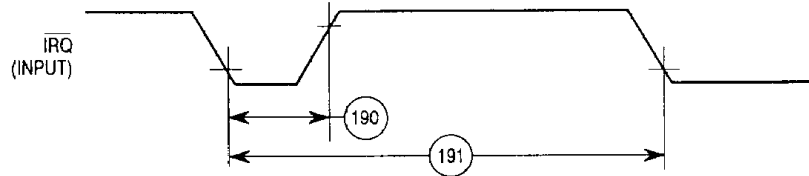

Figure 20. Interrupts Timing Diagram

## AC ELECTRICAL SPECIFICATIONS — TIMERS

(see Figure 21)

Num.	Characteristic	Symbol	16.67 MHz		Unit
			Min	Max	
200	Timer Input Capture Pulse Width	$t_{TPW}$	50	—	ns
201	TIN Clock Low Pulse Width	$t_{TICLT}$	50	—	ns
202	TIN Clock High Pulse Width	$t_{TICHT}$	1.5	—	clk
203	TIN Clock Cycle Time	$t_{cyc}$	3	—	clk
204	Clock High to TOUT Valid	$t_{CHTOV}$	—	35	ns
205	$\overline{FRZ}$ Input Setup Time (to Clock High) (see Note)	$t_{FRZSU}$	20	—	ns
206	$\overline{FRZ}$ Input Hold Time (from Clock High)	$t_{FRZHT}$	10	—	ns

NOTE:  $\overline{FRZ}$  should be negated during total system reset.

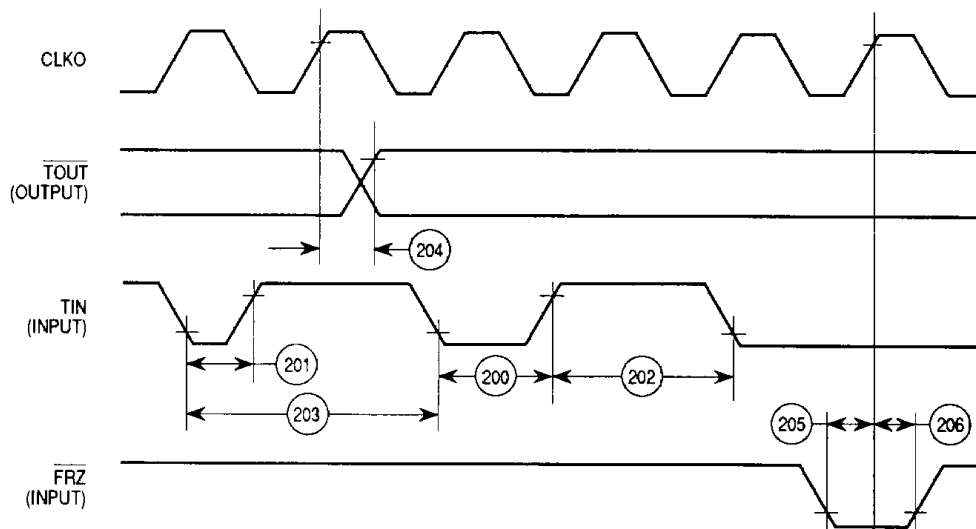

Figure 21. Timers Timing Diagram

**AC ELECTRICAL SPECIFICATIONS — SERIAL COMMUNICATION PORT**  
(see Figure 22)

Num.	Characteristic	16.67 MHz		Unit
		Min	Max	
250	SPCLK Clock Output Period	4	64	clks
251	SPCLK Clock Output Rise/Fall Time	—	15	ns
252	Delay from SPCLK to Transmit (see Note 1)	0	40	ns
253	SCP Receive Setup Time (see Note 1)	40	—	ns
254	SCP Receive Hold Time (see Note 1)	10	—	ns

NOTES:

1. This also applies when SPCLK is inverted by CI in the SPMODE register.
2. The enable signals for the slaves may be implemented by the parallel I/O pins.

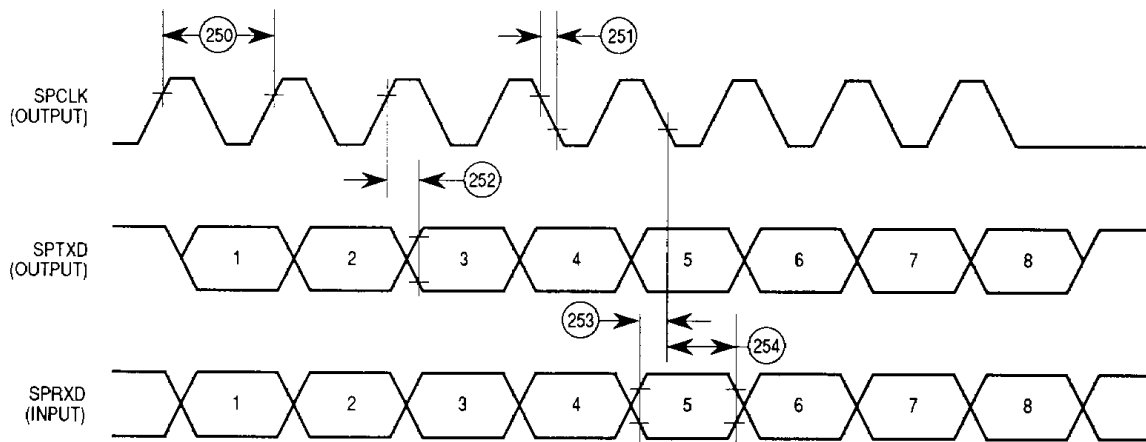

Figure 22. Serial Communication Port Timing Diagram

## AC ELECTRICAL SPECIFICATIONS — IDL TIMING

(All timing measurements, unless otherwise specified, are referenced to the L1CLK at 50% point of  $V_{DD}$ ) (see Figure 23)

Num.	Characteristic	16.67 MHz		Unit
		Min	Max	
260	L1CLK (IDL Clock) Frequency (see Note 1)	—	6.66	MHz
261	L1CLK Width Low	55	—	ns
262	L1CLK Width High	55	—	ns
263	L1TXD, L1RQ, SDS1–SDS2 Rising/Falling Time	—	20	ns
264	L1SY1 (sync) Setup Time (to L1CLK Falling Edge)	30	—	ns
265	L1SY1 (sync) Hold Time (from L1CLK Falling Edge)	50	—	ns
266	L1SY1 (sync) Inactive Before 4th L1CLK	0	—	ns
267	L1TXD Active Delay (from L1CLK Rising Edge)	0	90	ns
268	L1TXD to High Impedance (from L1CLK Rising Edge) (see Note 2)	0	50	ns
269	L1RXD Setup Time (to L1CLK Falling Edge)	50	—	ns
270	L1RXD Hold Time (from L1CLK Falling Edge)	50	—	ns
271	Time Between Successive IDL syncs	20	—	L1CLK
272	L1RQ Valid before Falling Edge of L1SY1	1	—	L1CLK
273	L1GR Setup Time (to L1SY1 Falling Edge)	50	—	ns
274	L1GR Hold Time (from L1SY1 Falling Edge)	50	—	ns
275	SDS1–SDS2 Active Delay from L1CLK Rising Edge	10	90	ns
276	SDS1–SDS2 Inactive Delay from L1CLK Falling Edge	10	90	ns

### NOTES:

1. The ratio CLK/L1CLK must be greater than 2.5:1.
2. High impedance is measured at the 30% and 70% of  $V_{DD}$  points, with the line at  $V_{DD}/2$  through 10K in parallel with 130 pF.

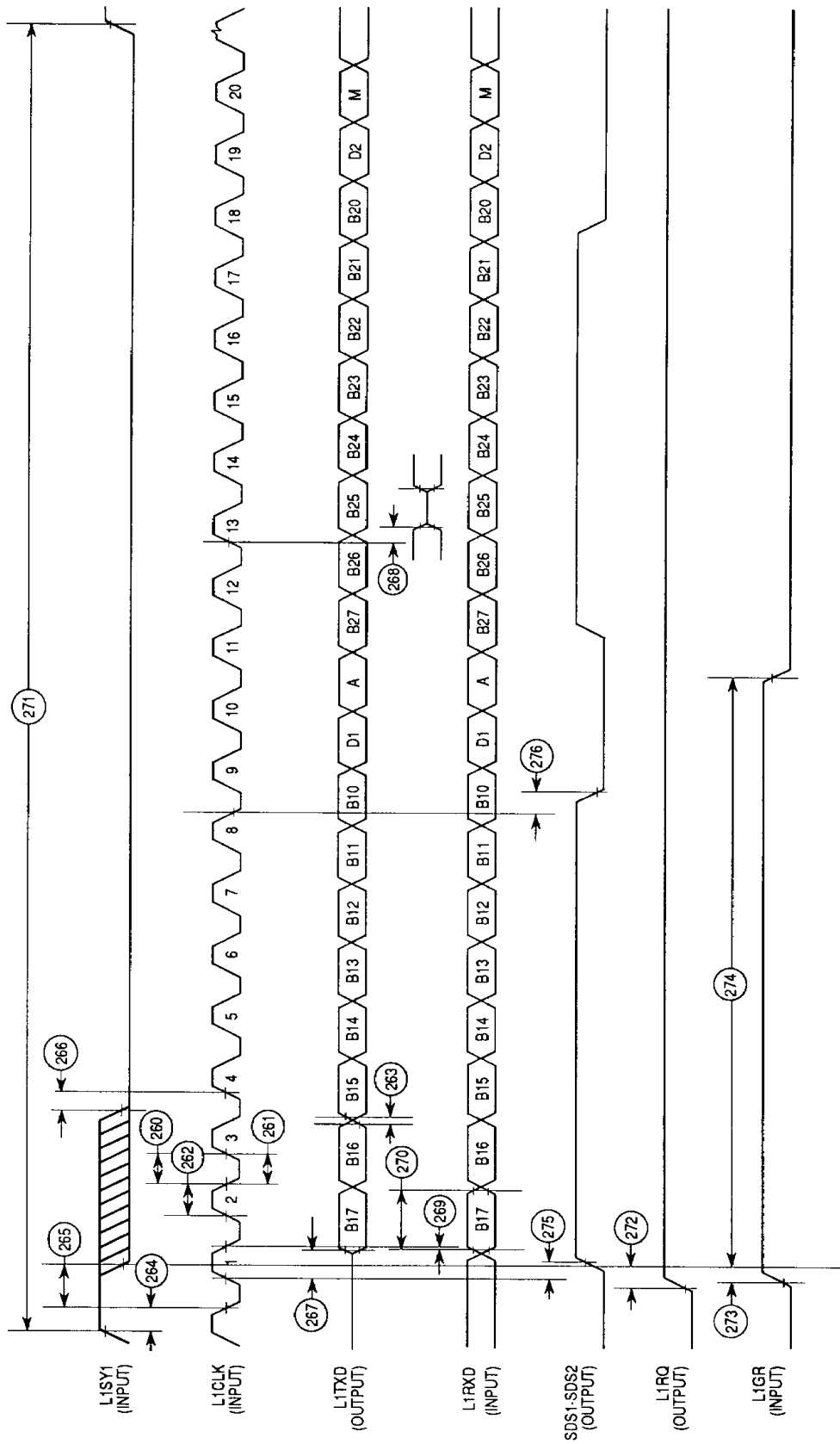

Figure 23. IDL Timing Diagram

## AC ELECTRICAL SPECIFICATIONS — GCI TIMING

GCI supports the NORMAL mode and the GCI channel 0 (GCN0) in MUX mode.

Normal mode uses 512 kHz clock rate (256K bit rate).

MUX mode uses  $256 \times n - 3088$  Kbits/sec (clock rate is data rate  $\times 2$ ).

The ratio CLK/L1CLK must be greater than 2.5/1.

(see Figure 24)

Num.	Characteristic	16.67 MHz		Unit
		Min	Max	
	L1CLK GCI Clock Frequency (Normal Mode) (see Note 1)	—	512	kHz
280	L1CLK Clock Period Normal Mode (see Note 1)	1800	2100	ns
281	L1CLK Width Low/High Normal Mode	840	1450	ns
282	L1CLK Rise/Fall Time Normal Mode (see Note 4)	—	—	ns
	L1CLK (GCI Clock) Period (MUX Mode) (see Note 1)	—	6.668	MHz
280	L1CLK Clock Period MUX Mode (see Note 1)	150	—	ns
281	L1CLK Width Low/High MUX Mode	55	—	ns
282	L1CLK Rise/Fall Time MUX Mode (see Note 4)	—	—	ns
283	L1SY1 Sync Setup Time to L1CLK Falling Edge	30	—	ns
284	L1SY1 Sync Hold Time from L1CLK Falling Edge	50	—	ns
285	L1TxD Active Delay (from L1CLK Rising Edge) (see Note 2)	0	100	ns
286	L1TxD Active Delay (from L1SY1 Rising Edge) (see Note 2)	0	100	ns
287	L1RxD Setup Time to L1CLK Rising Edge	20	—	ns
288	L1RxD Hold Time from L1CLK Rising Edge	50	—	ns
289	Time Between Successive L1SY1 in	Normal Mode 192	—	L1CLK L1CLK
290	SDS1–SDS2 Active Delay from L1CLK Rising Edge (see Note 3)	10	90	ns
291	SDS1–SDS2 Active Delay from L1SY1 Rising Edge (see Note 3)	10	90	ns
292	SDS1–SDS2 Inactive Delay from L1CLK Falling Edge	10	90	ns
293	GCI DCL (GCI Data Clock) Active Delay	0	50	ns

### NOTES:

1. The ratio CLK/L1CLK must be greater than 2.5/1.
2. Condition  $C_L = 150$  pF  
L1TxD becomes valid after the L1CLK rising edge or L1SY1, whichever is later.
3. SDS1–SDS2 become valid after the L1CLK rising edge or L1SY1, whichever is later.
4. Schmitt trigger used on input buffer.

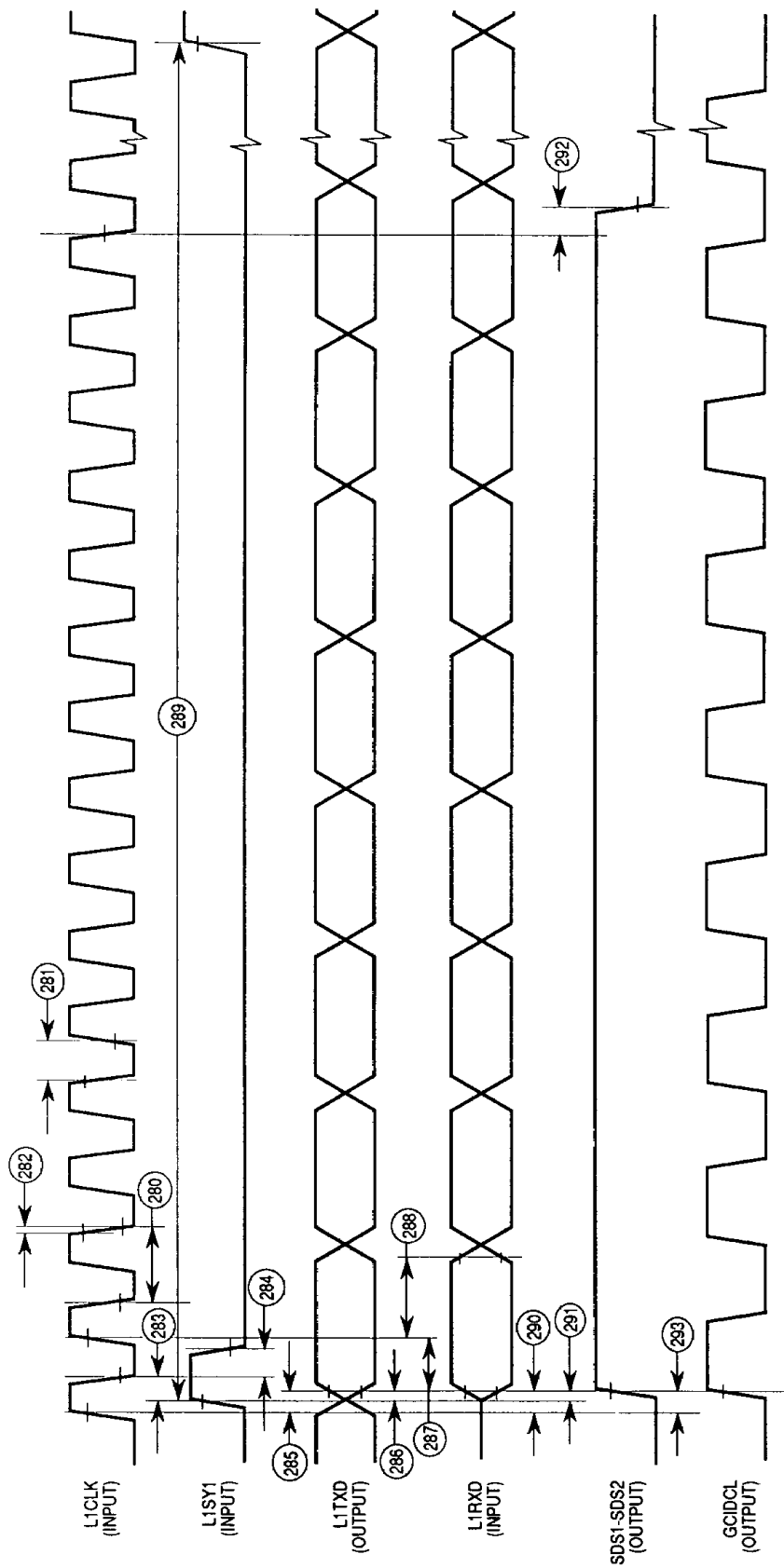

Figure 24. GCI Timing Diagram

## AC ELECTRICAL SPECIFICATIONS — PCM TIMING

There are two syncs types:

Short Frame — Sync signals are one clock cycle prior to the data

Long Frame — Sync signals are N-bits that envelope the data,  $N \geq 0$   
(see Figure 25)

Num.	Characteristic	16.67 MHz		Unit
		Min	Max	
300	L1CLK (PCM Clock) Frequency (see Note 1)	—	6.66	MHz
301	L1CLK Width Low/High	55	—	ns
302	L1SY0–L1SY1 Setup Time to L1CLK Falling Edge	20	—	ns
303	L1SY0–L1SY1 Hold Time from L1CLK Falling Edge	40	—	ns
304	L1SY0–L1SY1 Width Low	1	—	L1CLK
305	Time Between Successive Sync Signals (Short Frame)	8	—	L1CLK
306	L1TxD Data Valid after L1CLK Rising Edge (see Note 2)	0	100	ns
307	L1TxD to High Impedance (from L1CLK Rising Edge)	0	70	ns
308	L1RxD Setup Time (to L1CLK Falling Edge) (see Note 3)	20	—	ns
309	L1RxD Hold Time (from L1CLK Falling Edge) (see Note 3)	50	—	ns
310	L1TxD Data Valid After Syncs Rising Edge (Long) (see Note 2)	0	100	ns
311	L1TxD to High Impedance (from L1SY0–L1SY1 Falling Edge) (Long)	0	70	ns

### NOTES:

1. The ratio CLK/L1CLK must be greater than 2.5/1.
2. L1TxD becomes valid after the L1CLK rising edge or the sync enable, whichever is later, if long frames are used.
3. Specification valid for both sync methods.



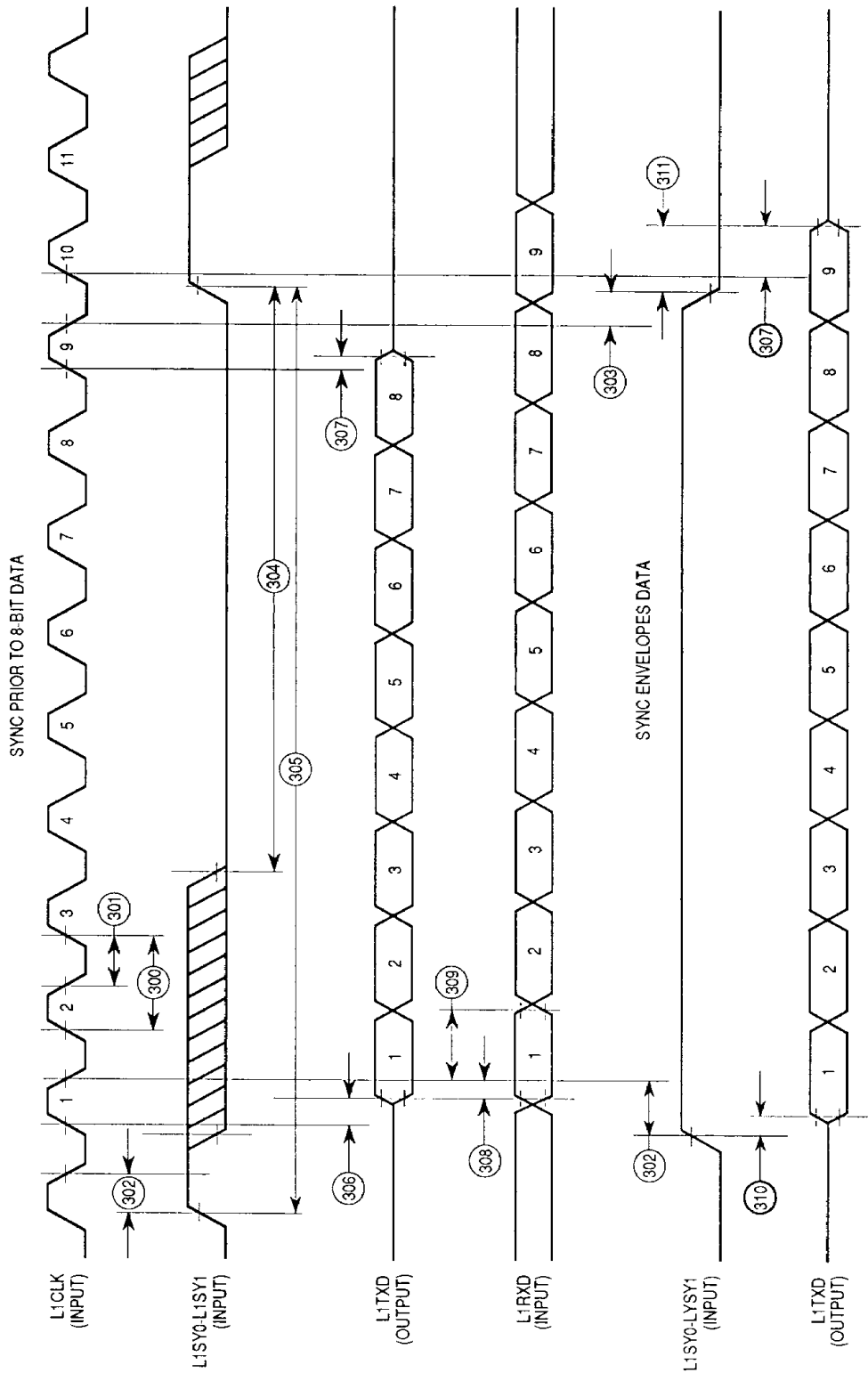

Figure 25. PCM Timing Diagram

## AC ELECTRICAL SPECIFICATIONS — NMSI TIMING

The NMSI mode uses two clocks, one for receive and one for transmit. Both clocks can be internal or external. When the clock is internal, it is generated by the internal Baud Rate Generator and it is output on L1RXD or L1TXD. All the timing is related to the external clock pin. The timing is specified for NMSI1. It is also valid for NMSI2 and NMSI3.

(see Figure 26)

Num.	Characteristic	Internal Clock		External Clock		Unit
		Min	Max	Min	Max	
315	RCLK1 and TCLK1 Frequency (see Note 1)	—	5.12	—	6.668	MHz
316	RCLK1 and TCLK1 Low/High	70	—	55	—	ns
317	RCLK1 and TCLK1 Rise/Fall Time (see Note 3)	—	—	—	—	ns
318	TxD1 Active Delay from TCLK1 Falling Edge	0	40	0	70	ns
319	RTS1 Active/Inactive Delay from TCLK1 Falling Edge	0	40	0	100	ns
320	CTS1 Setup Time to TCLK1 Rising Edge	50	—	10	—	ns
321	RXD1 Setup Time to RCLK1 Rising Edge	50	—	10	—	ns
322	RXD1 Hold Time from RCLK1 Rising Edge (see Note 2)	10	—	50	—	ns
323	CD1 Setup Time to RCLK1 Rising Edge	50	—	10	—	ns

### NOTE:

- The ratio CLK:TCLK1 and CLK:RCLK1 must be greater than 2.5:1 for external clock.  
For internal clock the ratio must be greater than 3:1 (the input clock to the baud rate generator may be either CLK or TIN1), in both cases the maximum frequency is limited to 16.67 MHz.  
In asynchronous mode (UART), the bit rate is 1/16 of the clock rate.
- Also applies to CD hold time when CD is used as an external sync in BISYNC or totally transparent mode.
- Schmitt triggers used on input buffers.

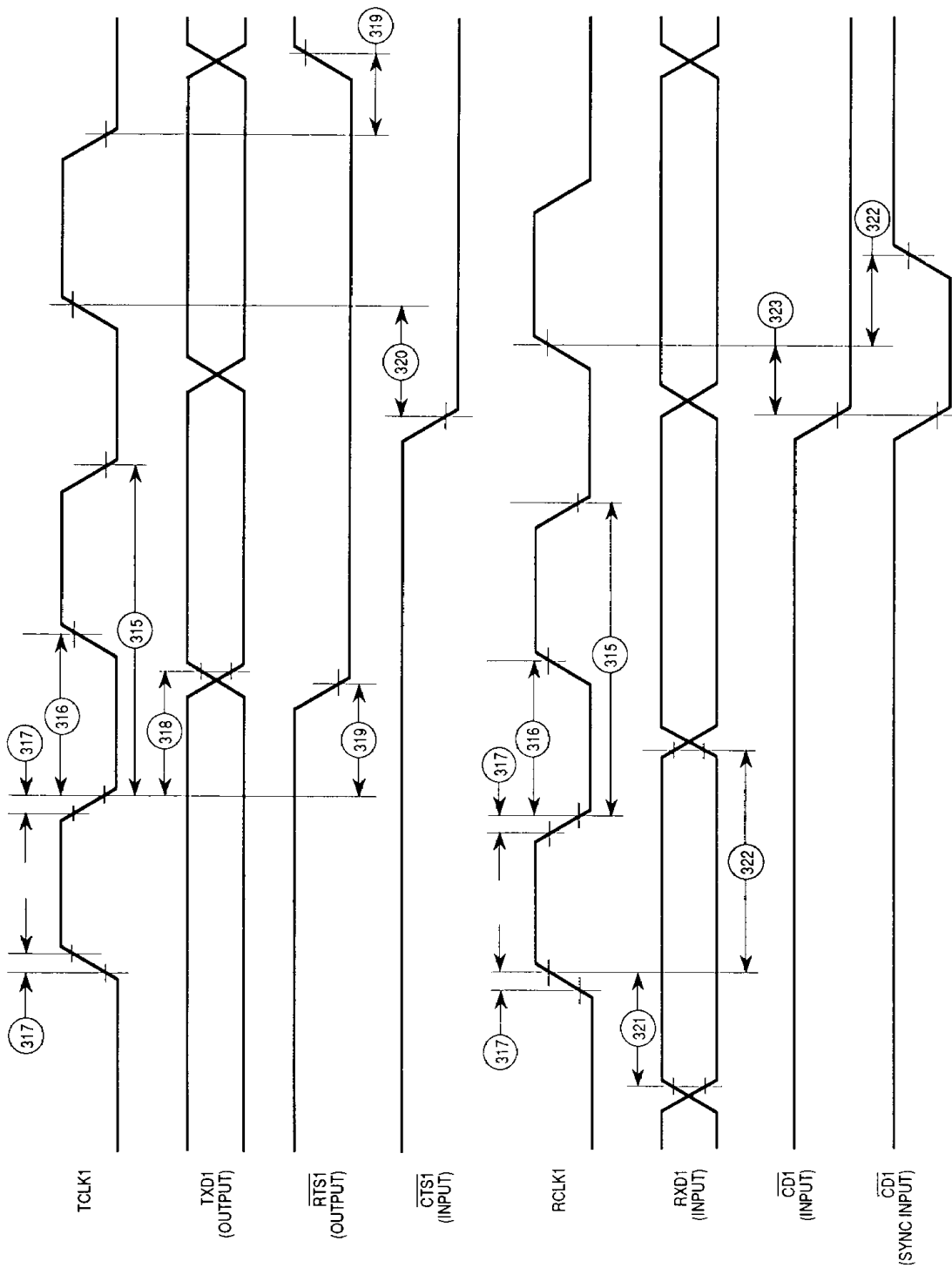
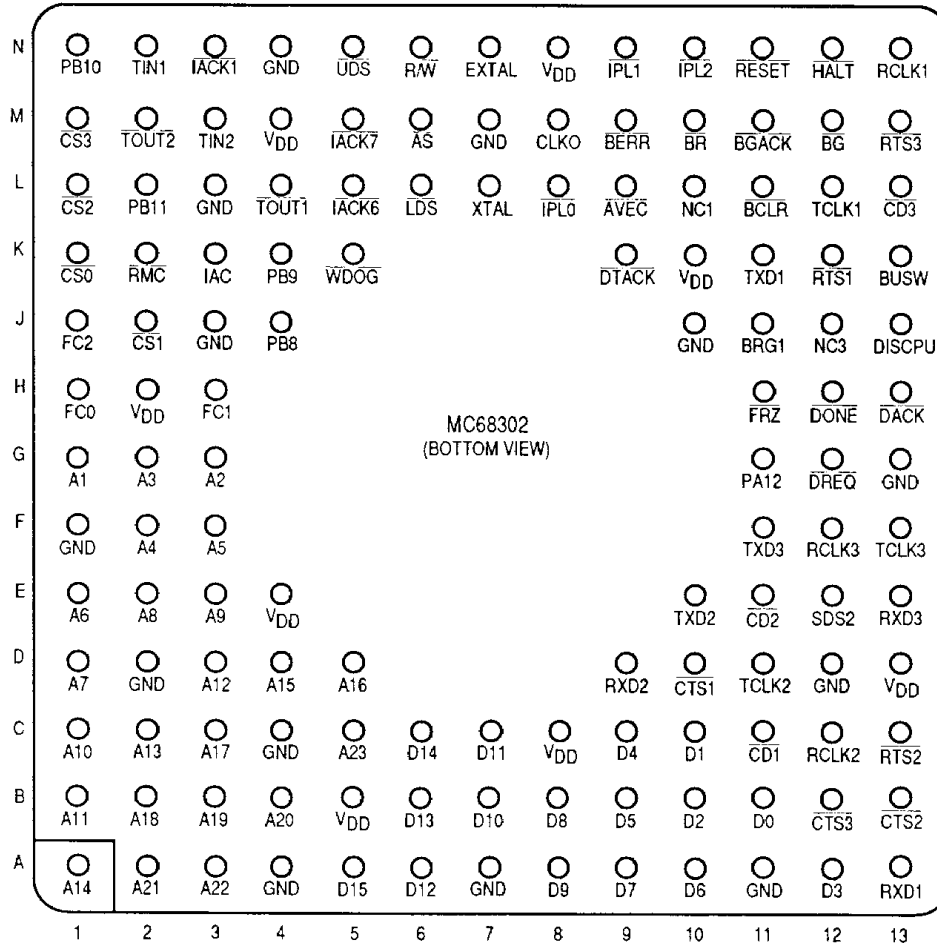

Figure 26. NMSI Timing Diagram

# PIN ASSIGNMENTS

## PIN GRID ARRAY (RC SUFFIX)

4



# CERAMIC SURFACE MOUNT (FE SUFFIX)

