

MCO-5S-P

SMD Clock Oscillator
Programmable



Features

- Small package 3.2 x 2.5 mm
- Output signal CMOS
- Programmable wide frequency range
- Short lead time for samples: 1 week max.

Parameter	Specification		
	MCO-5S18P	MCO-5S25P	MCO-5S3P
Frequency range	1 MHz ~ 133 MHz	1 MHz ~ 166 MHz	1 MHz ~ 200 MHz
Supply voltage	+1.8 V ±10 %	+2.5 V ±10 %	+3.3 V ±10 %
Supply current	1 ~ 75 MHz 76 ~ 133 MHz 134 ~ 166 MHz 167 ~ 200 MHz	< 8 mA < 12 mA - -	< 10 mA < 15 mA < 15 mA < 22 mA < 25 mA
Frequency stability	±25 ~ ±50 ppm		
all inclusive:	frequency stability, tolerance, aging, supply & load variation		
Output signal	CMOS		
Output level	$V_{OH} \geq 0.9 \text{ Vdc}$		$V_{OL} \leq 0.1 \text{ Vdc}$
Output load	15 pF ~ 25 pF		
Jitter (rms)	< 10 ps	@ 12 kHz ~ 20 MHz from carrier frequency	
Symmetry	45 ~ 55 %	@ ½ Vdc	
Rise/Fall time	4 ~ 10 ns		
Tri-state function	pin #1 = high or open pin #1 = low	pin #3 → signal pin #3 → high impedance	
Operating temperature range	-20 ~ +70 °C -40 ~ +85 °C	commercial application industrial application	
Storage temperature range	-55 ~ +125 °C		
Packaging units	tape & reel tape only	1'000 or 2'500 pieces < 500 pieces	

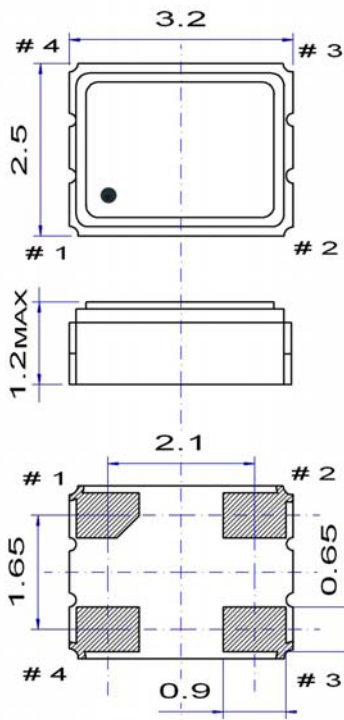

Pin function

- # 1 Tri-state
- # 2 GND
- # 3 Output
- # 4 Vdc

Example for solder pattern

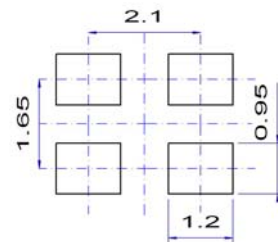

Do not design any conductive path between the pattern

Example for IR reflow soldering temperature

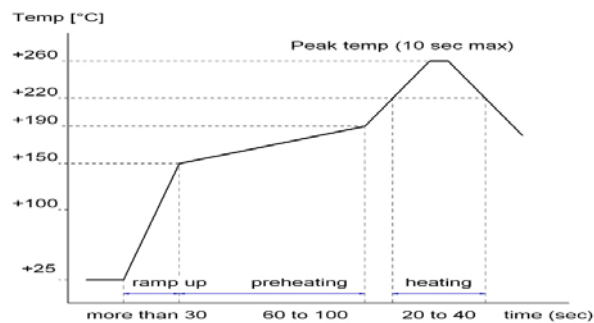

2002/95/EC RoHS compliant

31 Mar. 10

QuartzCom AG
sales@quartzcom.com

QuartzCom Asia
sales-asia@quartzcom.com

QuartzCom USA
sales-usa@quartzcom.com

www.quartzcom.com

