

Infrared Encoder/Decoder

Features

- Pinout compatible with HSDL-7000
- Compliant with IrDA[®] Standard Physical Layer Specification (version 1.3)
- UART to IrDA Standard Encoder/Decoder
 - Interfaces with IrDA Standard Compliant Transceiver
- Baud Rates:
 - Up to IrDA Standard 115.2 Kbaud Operation
- Transmit/Receive Formats (Bit Width) Supported:
 - 1.63 μ s
- Low-power Mode (2 μ A at 1.8V, +125°C)
- Pb-free packaging

CMOS Technology

- Low-voltage operation
- Extended temperature range
- Low power consumption

Package Types

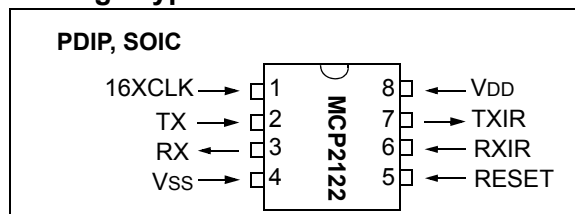

Block Diagram

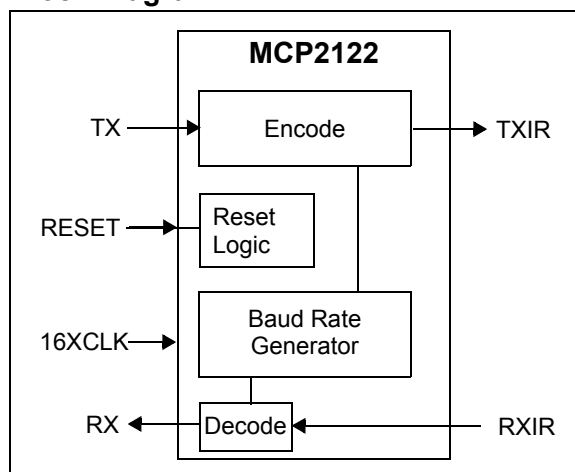

IrDA Family Selection

Device	Baud Rate		Encoder / Decoder	Protocol Layer Handler	Clock Source	Host UART Baud Rate Selection	Comment
	Host UART	IR					
MCP2120	2400 - 312,500 ⁽¹⁾	2400 - 312,500 ⁽¹⁾	Yes	No	XTAL	HW/SW	
MCP2122	2400 - 115,200 ⁽¹⁾	2400 - 115,200 ⁽¹⁾	Yes	No	16XCLK	By 16XCLK	Extended Temperature Range (-40°C to +125°C)
MCP2140	9600	9600	Yes	IrCOMM ⁽³⁾	XTAL	None - Fixed	
MCP2150	9600 - 115,200 ⁽²⁾	9600 - 115,200 ⁽²⁾	Yes	IrCOMM ⁽³⁾	XTAL	HW	Host UART easily interfaces to a PC's serial port (DTE)
MCP2155	9600 - 115,200 ⁽²⁾	9600 - 115,200 ⁽²⁾	Yes	IrCOMM ⁽³⁾	XTAL	HW	Host UART easily interfaces to a modem's serial port (DCE)

Note 1: The host UART and the IR operate at the same baud rates.

2: The host UART and IR baud rates operate independent of each other.

3: Supports the 9-wire "cooked" service class of the IrCOMM Application Layer Protocol.

MCP2122

NOTES:

1.0 DEVICE OVERVIEW

The MCP2122 is a stand-alone IrDA standard encoder/decoder device that is pinout-compatible with the Agilent® HSDL-7000 encoder/decoder.

The MCP2122 has two interfaces: the host UART interface and the IR interface (see Figure 1-1). The host UART interfaces to the UART of the Host Controller. The Host Controller is the device in the embedded system that transmits and receives the data. The IR interface connects to an infrared (IR) optical transceiver circuit that converts electrical pulses into IR light (encode) and converts IR light into electrical pulses (decode). This IR optical transceiver circuit could be either a standard infrared optical transceiver (such as a Vishay® TFDU 4300) or it could be implemented with discrete components. For additional information, please refer to AN243, "Fundamentals of the Infrared Physical Layer" (DS00243).

When the Host Controller transmits the UART format data, the MCP2122 receives this UART data and encodes (modulates) it bit by bit. This encoded data is then output as electrical pulses to the IR transceiver. The IR transceiver will then convert these electrical pulses to IR light pulses.

The IR transceiver also receives IR light pulses (data), which are outputted as electrical pulses. The MCP2122 decodes (demodulates) these electrical pulses, with the data then being transmitted by the MCP2122 UART. This modulation/demodulation method is performed in accordance with the IrDA standard.

Table 1-1 shows an overview of some of the device features. Figure 1-1 shows a typical application block diagram. Table 1-2 shows the pin definitions of the MCP2122 during normal operation.

TABLE 1-1: MCP2122 FEATURES OVERVIEW

Features	MCP2122
Serial Communications:	UART, IR
Baud Rate Selection:	16XCLK
Low-power Mode:	Yes
Packages:	8-pin PDIP 8-pin SOIC

Infrared Technology Features:

- Universal standard for connecting portable computing devices
- Effortless implementation
- Economical alternative to other connectivity solutions
- Reliable, high-speed connection
- Safe to use in any environment; can even be used during air travel
- Eliminates the hassle of cables
- Allows PCs and non-PCs to communicate with each other
- Enhances mobility by allowing users to easily connect

1.1 Applications

Some applications where an IR interface (MCP2122) could be used include:

- Data-Logging/Data Exchange
- System Setup
- System Diagnostic Read Out
- Manufacturing Configuration
- Host Controller Firmware Updates
- System Control

FIGURE 1-1: SYSTEM BLOCK DIAGRAM

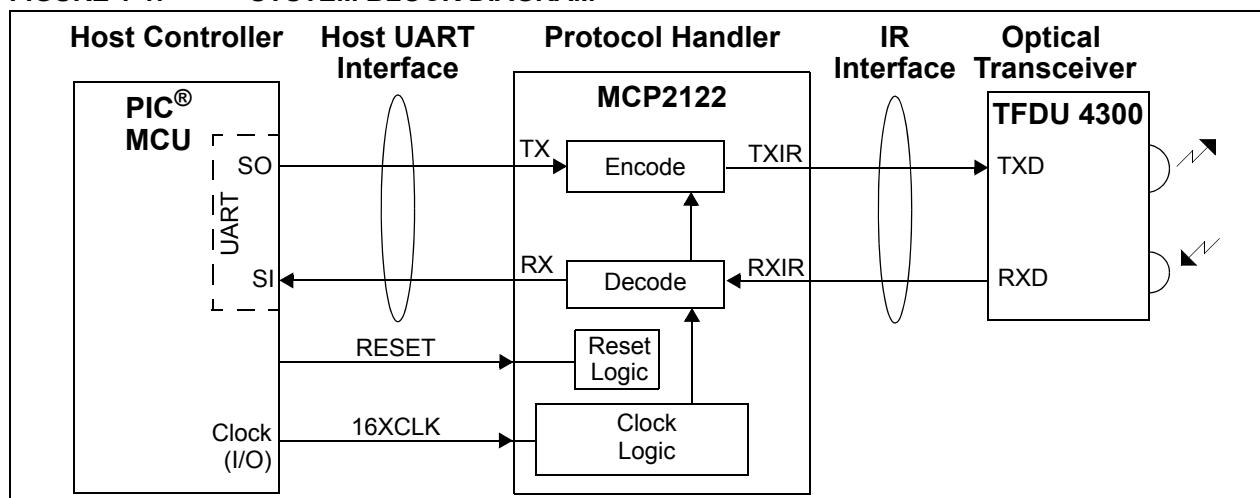

MCP2122

TABLE 1-2: PIN DESCRIPTION

Pin Name	Pin Number		Pin Type	Buffer Type	Description
	PDIP	SOIC			
16XCLK	1	1	I	ST	16x external clock source input
TX	2	2	I	ST	Asynchronous receive from Host Controller UART
RX	3	3	O	—	Asynchronous transmit to Host Controller UART
Vss	4	4	—	P	Ground reference for logic and I/O pins
RESET	5	5	I	ST	Resets the Device H = Normal Operation L = Device in Reset
RXIR	6	6	I	ST	Asynchronous receive from infrared transceiver
TXIR	7	7	O	—	Asynchronous transmit to infrared transceiver
VDD	8	8	—	P	Positive supply for logic and I/O pins

Legend: ST = Schmitt Trigger input with CMOS levels

- I = Input
- P = Power
- O = Output

2.0 DEVICE OPERATION

The MCP2122 is a low-cost infrared encoder/decoder. The baud rate is the same for the host UART and IR interfaces and is determined by the frequency of the 16XCLK signal, with a maximum baud rate of 115.2 Kbaud.

The MCP2122 is made up of these functional modules:

- Clock Driver (16XCLK)
- Reset
- IR Encoder/Decoder
 - IrDA Standard Encoder
 - IrDA Standard Decoder

The **16XCLK** circuit allows a clock input to provide the device clock.

The **Reset** circuit supports an external reset signal.

The **IR Encoder** logic takes a data bit and converts it to the IrDA standard signal according to the IrDA standard Physical Layer specification, while the **IR Decoder** logic takes the IrDA standard signal and converts it to 8-bit data bytes.

2.1 Power-up

As the device is powered up, there will be a voltage range in which the device will not operate properly. The device should be reset once it has entered the normal operating range (from an out-of-voltage condition). The RESET pin may then be forced high.

Other device operating parameters (such as frequency, temperature, etc.) must also be within their operating ranges when the device exits reset. Otherwise, the device may not function as desired.

2.2 Device Reset

The MCP2122 is forced into the known state (RESET) when the RESET pin is in the low state. Once the RESET pin is brought to a high state, the device begins normal operation (if the device operating parameters are met). [Table 2-1](#) shows the states of the output pins while the device is in reset (RESET = Low). [Table 2-2](#) shows the state of the output pins once the device exits reset, RESET = L→H (device in Normal Operation mode).

The MCP2122 has a RESET noise filter in the RESET input signal path. The filter will detect and ignore small pulses.

Using the RESET pin to enter a low-power state is discussed in [Section 2.9 “Minimizing Power”](#).

TABLE 2-1: DEFAULT OUTPUT PIN STATES IN DEVICE RESET

Input Pin		Output Pin State		Comments
Name	State	RX	TXIR	
RESET	L	H	L	Device in Reset mode

TABLE 2-2: DEFAULT OUTPUT PIN STATES AFTER DEVICE RESET (RESET = L→H)

Input Pin		Output Pin State		Comments
Name	State	RX	TXIR	
TX	L	—	L→H →L	After 7 - 8 16XCLK pulses, the TXIR pin will pulse high.
	H	—	L	
RXIR	L	H→L	—	After 4 16XCLK pulses, RX = L.
	H	H	—	

2.3 Decoupling

It is highly recommended that the MCP2122 have a decoupling capacitor (CBYP). A 0.01 μF capacitor is recommended as a starting value, but an evaluation of the best value for your circuit/layout should be performed. Place this decoupling capacitor (CBYP) as close to the MCP2122 as possible (see [Figure 2-1](#)).

FIGURE 2-1: DEVICE DECOUPLING

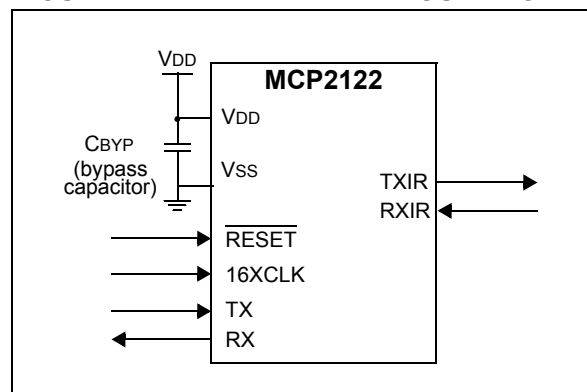

MCP2122

2.3.1 BROWN-OUTS

Some applications may subject the MCP2122 to a brown-out condition. Good design practice requires that when a system is in brown-out, the system should be in reset to ensure that the system is in a known state when the system exits the brown-out. This brown-out circuitry is external to the MCP2122.

2.3.1.1 External Brown-Out Reset Circuits

Figure 2-2 shows a circuit for external brown-out protection using the TCM809 device.

Figure 2-3 and Figure 2-4 illustrate two examples of external circuitry that may be implemented. Each option needs to be evaluated to determine if they satisfy the requirements of the application.

FIGURE 2-2: EXTERNAL BROWN-OUT PROTECTION USING THE TCM809

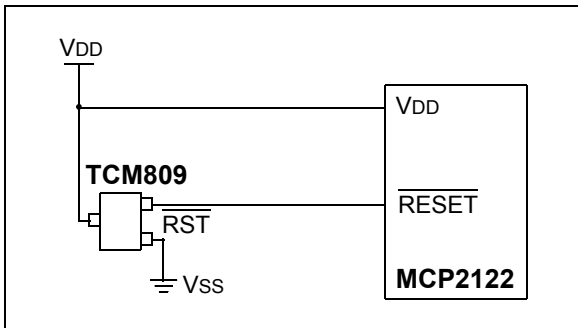
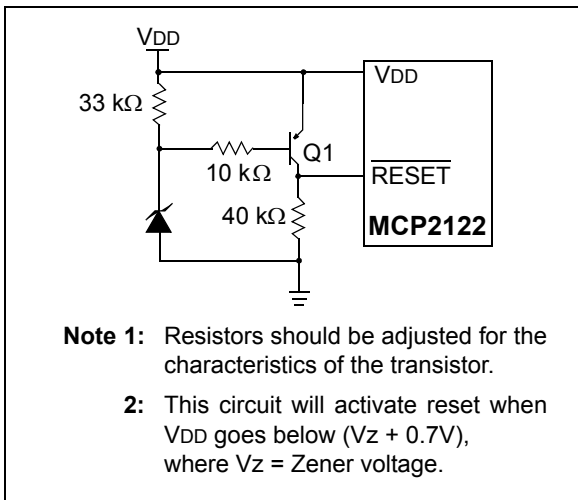
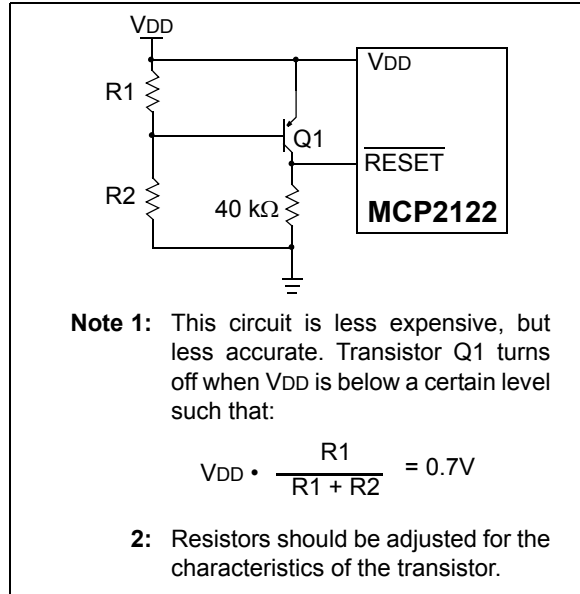

FIGURE 2-3: EXTERNAL BROWN-OUT PROTECTION CIRCUIT 1



- Note 1:** Resistors should be adjusted for the characteristics of the transistor.
- 2:** This circuit will activate reset when VDD goes below (Vz + 0.7V), where Vz = Zener voltage.

FIGURE 2-4: EXTERNAL BROWN-OUT PROTECTION CIRCUIT 2



2.4 16XCLK (Bit Clock)

The MCP2122 requires an external clock source to operate. The 16XCLK pin is the device clock input (see Figure 2-5) and is independent of the host UART interface or the IR interface. The 16XCLK determines all timing during device operation. It is the edge of the 16XCLK pin that causes activity to occur.

The 16XCLK signal can also be referred to as a bit clock (BITCLK). There are 16 BITCLKs for each bit time. The BITCLKs are used for the generation of the Start bit, the eight data bits and the Stop bit.

When the embedded system could be receiving IR communication, the MCP2122 is required to have the 16XCLK signal clocking at the expected frequency, with minimal variation in that frequency. Between data bytes (Stop bit to Start bit), the 16XCLK frequency can be changed. This may occur in systems where the Host Controller is implementing one of the IrDA standard application layer protocols (such as IrObex).

When the embedded system does not want to receive IR communications, the 16XCLK clock can be disabled (static). This will reduce the power consumption of the system.

Figure 2-6 shows the relationship of the 16XCLK signal to the RXIR input, which then determines the RX output signal. Figure 2-7 shows the relationship of the 16XCLK signal to the TX input, which then determines the TXIR output signal. For device timing information, refer to Section 4.0 "Electrical Characteristics".

FIGURE 2-5: DEVICE CLOCK SOURCE

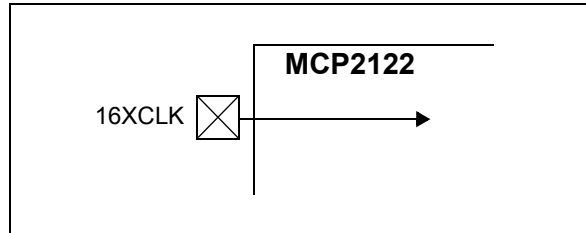

FIGURE 2-6: 16XCLK AND RX/RXIR

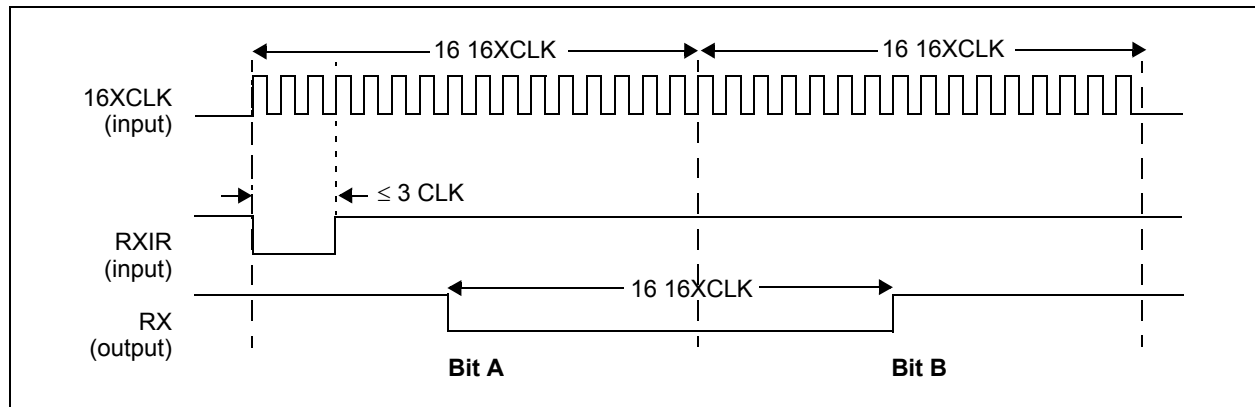
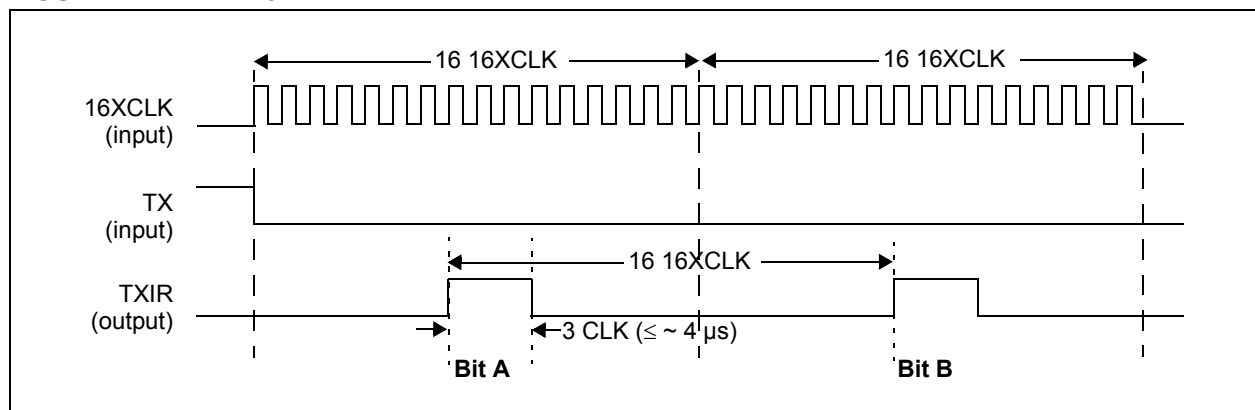

FIGURE 2-7: 16XCLK AND TX/TXIR



MCP2122

2.4.1 BAUD RATE

The baud rate for the MCP2122 is determined by the frequency of the 16XCLK signal. Equation 2-1 demonstrates how to calculate the 16XCLK frequency based on the desired baud rate. Table 2-3 shows some common baud rates and the corresponding 16XCLK frequency.

EQUATION 2-1: 16XCLK FREQUENCY

$$F_{16XCLK} = 16 \bullet (\text{Desired Baud Rate})$$

TABLE 2-3: COMMON BAUD RATE/ 16XCLK FREQUENCY

Baud Rate	16XCLK Frequency (F _{16XCLK})	Comment
9600	153,600	
19,200	307,200	
38,400	614,400	
57,600	921,600	
115,200	1,843,200	

2.5 Encoder/Decoder

The IR encoder/decoder is made up of two major components. They are:

- IR Decoder
- IR Encoder

The encoder receives UART data (bit by bit) and outputs a data bit in the IrDA standard bit format. Figure 2-8 shows a functional block diagram of the encoder.

The decoder receives IrDA standard data (bit by bit) and outputs data in UART data bit format. Figure 2-8 shows a functional block diagram of the decoder.

The encoder/decoder has two interfaces. They are:

- Host UART interface
- IR interface

2.5.1 ENCODING (MODULATION)

Each bit time is comprised of 16 bit clocks. If the value to be transmitted (as determined by the TX pin) is a logic-low, the TXIR pin will output a low level for 7-bit clock cycles, a logic-high level for 3-bit clock (with a maximum high-time of about 4 μs) cycles, with the remaining time (6-bit clock cycles or more) being low. If the value to transmit is a logic-high, the TXIR pin will output a low level for the entire 16 bit clock cycle.

2.5.2 DECODING (DEMODULATION)

Each bit time is comprised of 16 bit clocks. If the value to be received is a logic-low, the RXIR pin will be a low level for the first 3-bit clock cycle (or a minimum of 1.6 μs), with the remaining time (13-bit clock cycles) being high. If the value to be received is a logic-high, the RXIR pin will be a high level for the entire 16-bit clock cycle. The level on the RX pin will be in the appropriate state for an entire 16-bit clock cycle.

FIGURE 2-8: MCP2122 RECEIVE DETECT TO ENCODER/DECODER BLOCK DIAGRAM

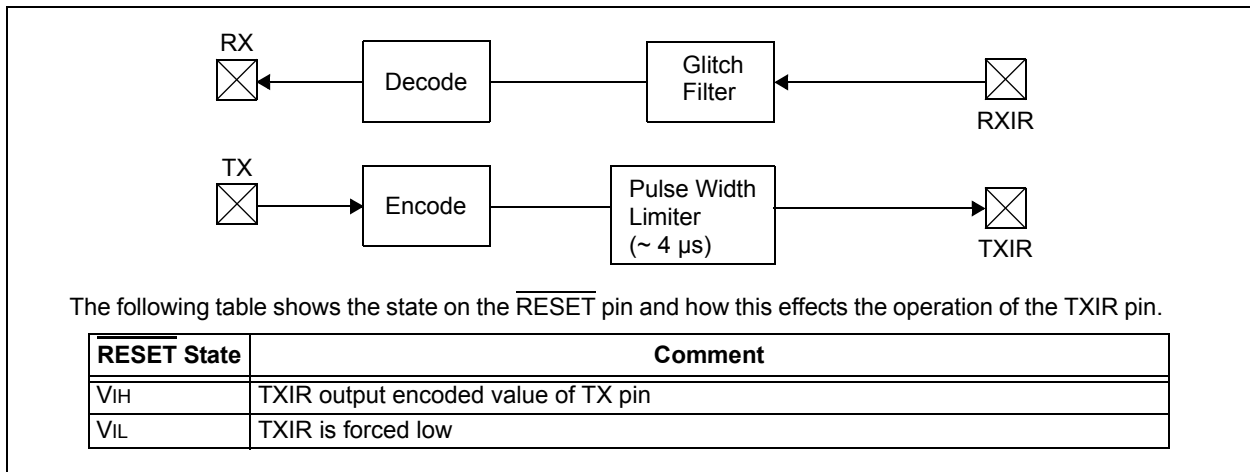

2.5.3 ENCODING AND SCREEN CAPTURES

Table 2-4 shows the TXIR pin high-time at different common baud rates. The internal TXIR pulse-width high-time limiter is a feature that minimizes the system current consumption at lower baud rates. The IrDA standard specification requires that optical receiver circuitry detect pulses as narrow as 1.41 μs (1.63 μs is the typical time at 115200 baud). Therefore, the time that the TXIR pin is high after this valid detection is additional current that is driven by the emitter LED. The MCP2122 will force the TXIR pin low once the pulse-width limiter has timed out. Figure 2-9 shows the MCP2122 16XCLK, TX and TXIR waveforms at 115200 baud for a single TX low bit. In this case, the TXIR is high for three 16XCLK pulses. In Figure 2-10, the MCP2122 is at 9600 baud for a single TX low bit. In this case, the TXIR is high for 3.55 μs (determined by pulse-width limiter circuit).

TABLE 2-4: TXIR HIGH PULSE WIDTH

Baud Rate	TXIR Pulse Width		
	3xT16XCLK Circuit	Pulse-width Limiter (2)	Actual Pulse Width
9600	19.53 μs (1)	4.00 μs	4.00 μs (3)
19200	9.77 μs (1)	4.00 μs	4.00 μs (3)
38400	4.88 μs (1)	4.00 μs	4.00 μs (3)
57600	3.26 μs	4.00 μs	3.26 μs
115200	1.63 μs	4.00 μs	1.63 μs

- Note 1:** The pulse-width limiter on the TXIR pin saves system current for this baud rate.
- 2:** This TXIR pulse width time is a design target and is not tested. Actual times may be greater than, or less than, this value.
- 3:** This time (determined by the pulse-width limiter circuit) is device dependent.

FIGURE 2-9: MCP2122 AT 115200 BAUD WAVEFORM

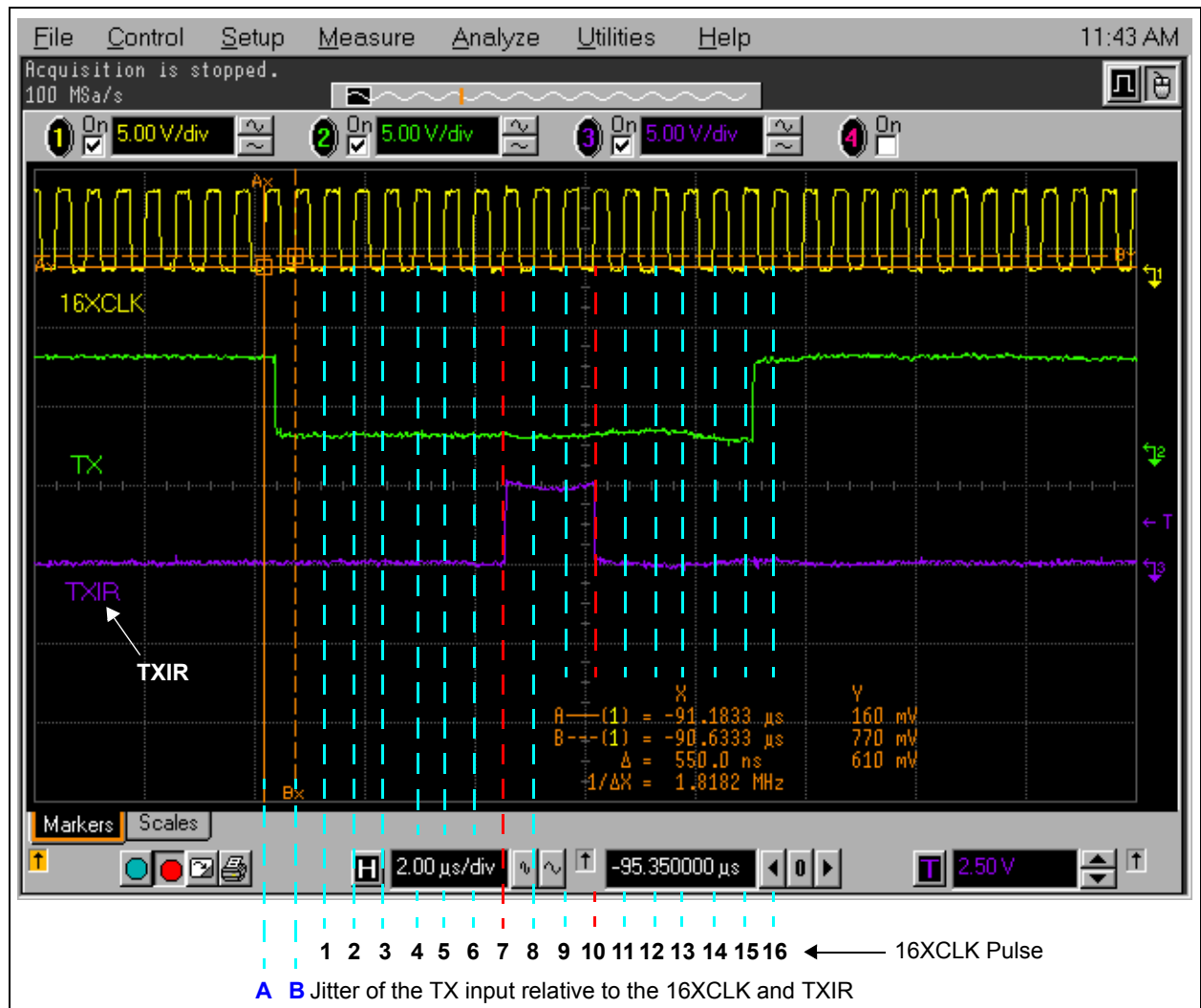

MCP2122

FIGURE 2-10: MCP2122 AT 9600 BAUD WAVEFORM

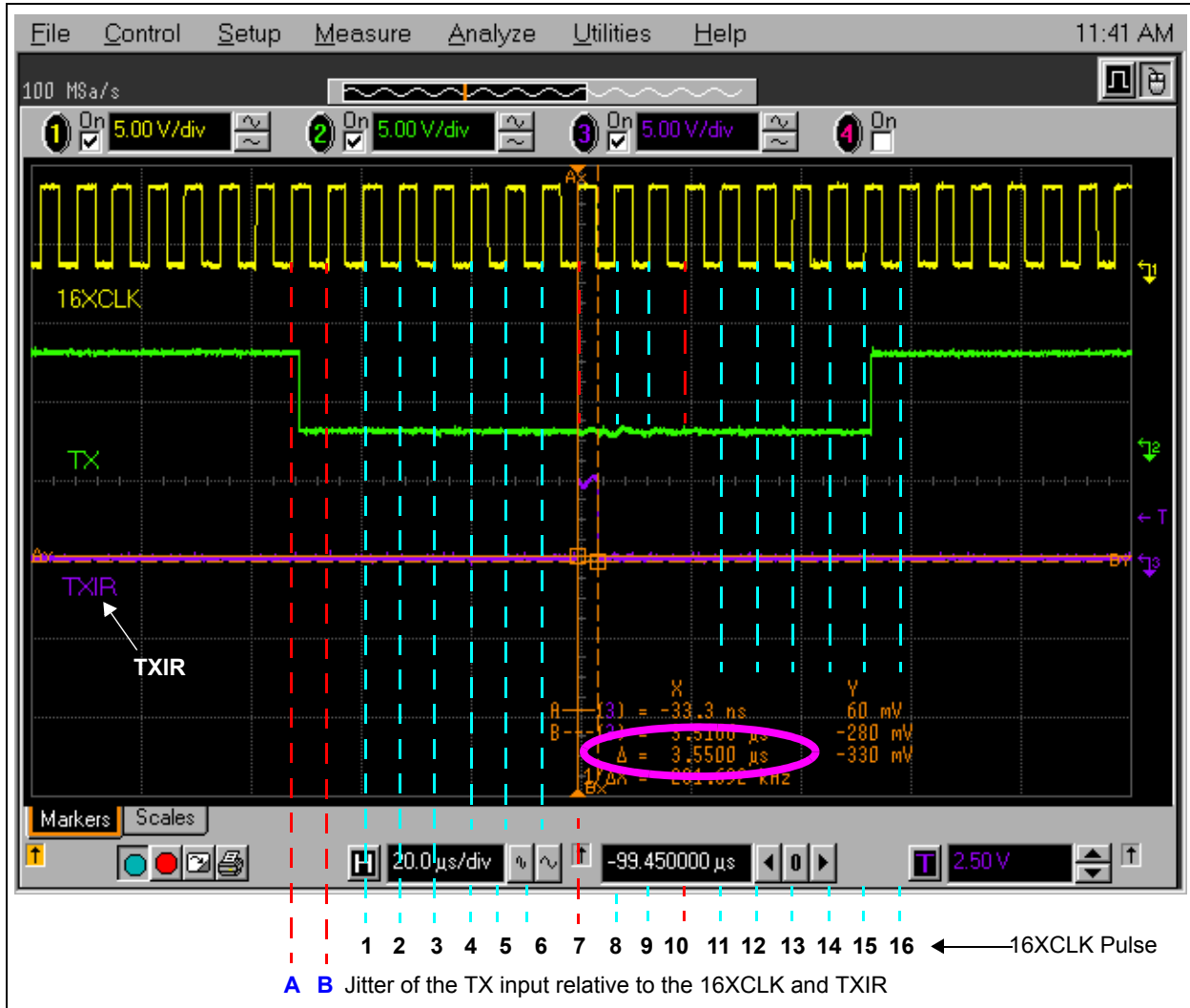

2.6 Host UART Interface

The UART interface is used to communicate with the Host Controller. Though a UART is capable of a full-duplex interface, the direct coupling to the IR encoder/decoder allows only half-duplex operation (since the IR side is either receiving or transmitting and not both at the same time). This means that the system can't transmit and receive at the same time.

2.6.1 TRANSMITTING

When the controller sends serial data to the MCP2122, the baud rates are required to match.

There will be some jitter on the detection of the high-to-low edge of the start bit. This jitter will affect the placement of the encoded start bit. All subsequent bits will be 16 BITCLK times later.

While RXIR is receiving data (low pulse), the TXIR pin is disabled from transmitting.

2.6.2 RECEIVING

When the controller receives serial data from the MCP2122, the baud rates are required to match.

There will be some jitter on the detection of the high-to-low edge of the Start bit. This jitter will affect the placement of the decoded Start bit. All subsequent bits will be 16 BITCLK times later.

The TXIR pin is disabled when data is being received (low pulse) on the RXIR pin.

2.7 IR Interface

The IR interface is used to communicate with the optical receiver circuitry. The IR interface is either transmitting data or receiving data (half-duplex).

2.8 Encoding/Decoding Jitter and Offset

Figure 2-11 shows the jitter on the RXIR and TX pins, along with the offset on the RX pin and the TXIR pin.

Jitter is the possible variation of the desired edge. Figure 2-9 and Figure 2-10 show the jitter of the TX pin (range is indicated by red dashed lines).

Offset is the propagation delay of the input signal (RXIR or TX) to the output signal (RX or TXIR). Figure 2-9 and Figure 2-10 show the offset of the TXIR pin from the 16XCLK signal that starts the bit time.

2.9 Minimizing Power

The device can be placed in a low-power mode by forcing the RESET pin low. This disables the internal state machine. To ensure that the lowest power consumption is obtained, ensure that the 16XCLK pin is not active and that the other input pins (TX and RXIR) are at a logic-high or logic-low level.

2.9.1 RETURNING TO OPERATION

When returning to normal operation, the RESET pin must be forced high and the 16XCLK signal should be operating. Time should be given to ensure that the 16XCLK is stabilized at the desired frequency before data is allowed to be transmitted or received.

FIGURE 2-11: EFFECTS OF JITTER AND OFFSET

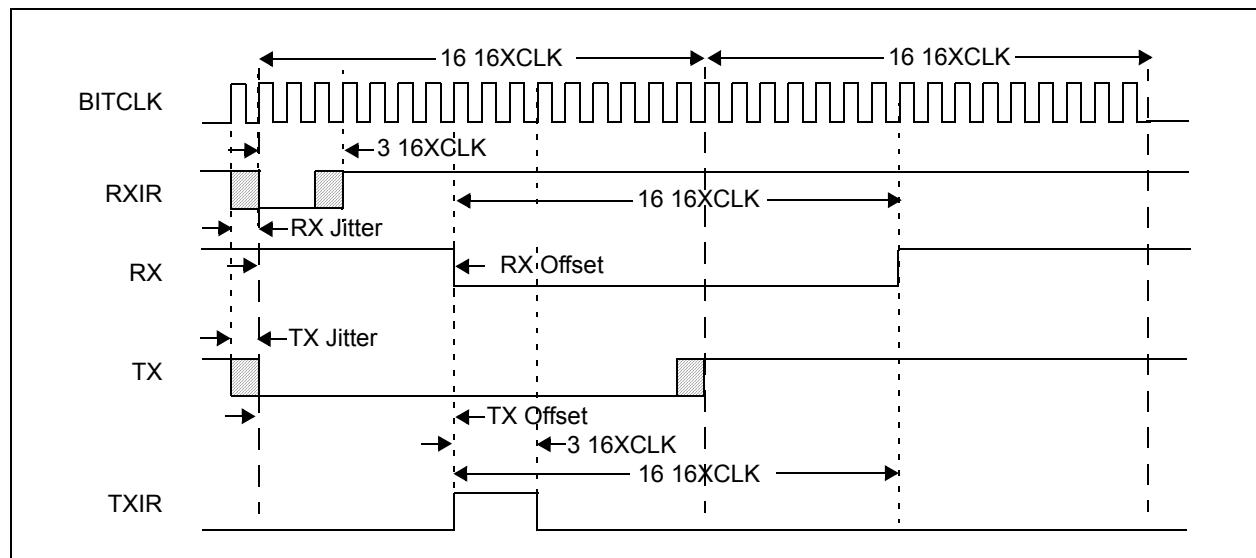

MCP2122

NOTES:

3.0 DEVELOPMENT TOOLS

The MCP212X Developer's Daughter Board is used to evaluate and demonstrate the MCP2122 or the MCP2120 IrDA® Standard Encoder/Decoder devices.

A header allows the MCP212X Developer's Daughter Board to be jumpered easily into systems for development purposes.

The MCP212X Developer's Daughter Board is designed to interface to several of the "new" low cost PIC® Demo Boards. These include the PICDEM HPC Explorer Demo board, the PICDEM FS USB Demo board, and the PICDEM LCD Demo board.

When the MCP212X Developer's Daughter Board is used in conjunction with the PICDEM HPC Explorer Demo board, the MCP212x can be connected to either of the PIC18F8772's two UARTs or the RX and TX signals can be "crossed" so the MCP212x device can communicate directly out the PICDEM HPC Explorer Demo Board's UART (DB-9).

Features:

- 8-pin socket for installation of MCP2122 (installed) and 14-pin socket for installation of MCP2120
- Three Optical Transceiver circuits (1 installed)
- Headers to interface to low cost PICDEM Demo Boards, including:
 - • PICDEM™ HPC Explorer Demo Board
 - • PICDEM™ LCD Demo Board
 - • PICDEM™ FS USB Demo Board
 - • PICDEM™ 2 Plus Demo Board
- Headers to easily connect to the user's embedded system
- Jumpers to select routing of MCP212X signals to the PICDEM™ Demo Board Headers
- Jumpers to configure the operating mode of the board

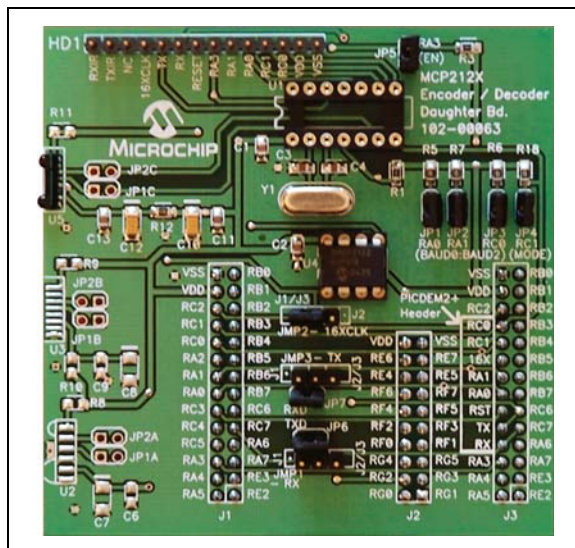

MCP2122

NOTES:

4.0 ELECTRICAL CHARACTERISTICS

Absolute Maximum Ratings†

Ambient Temperature under bias	-40°C to +125°C
Storage Temperature	-65°C to +150°C
Voltage on VDD with respect to VSS	-0.3V to +6.5V
Voltage on $\overline{\text{RESET}}$ with respect to VSS	-0.3V to +14V
Voltage on all other pins with respect to VSS	-0.3V to (VDD + 0.3V)
Total Power Dissipation ⁽¹⁾	800 mW
Max. Current out of VSS pin	500 mA
Max. Current into VDD pin	500 mA
Input Clamp Current, I _{IK} (V _I < 0 or V _I > VDD)	±20 mA
Output Clamp Current, I _{OK} (V _O < 0 or V _O > VDD).....	±20 mA
Max. Output Current sunk by any Output pin.....	25 mA
Max. Output Current sourced by any Output pin.....	25 mA

Note 1: Power Dissipation is calculated as follows:

$$P_{DIS} = V_{DD} \times \{I_{DD} - \sum I_{OH}\} + \sum \{(V_{DD} - V_{OH}) \times I_{OH}\} + \sum (V_{OL} \times I_{OL})$$

†**NOTICE:** Stresses above those listed under "Maximum Ratings" may cause permanent damage to the device. This is a stress rating only and functional operation of the device at those or any other conditions above those indicated in the operation listings of this specification is not implied. Exposure to maximum rating conditions for extended periods may affect device reliability.

MCP2122

FIGURE 4-1: VOLTAGE-FREQUENCY (16XCLK) GRAPH, $-40^{\circ}\text{C} \leq T_A \leq +125^{\circ}\text{C}$

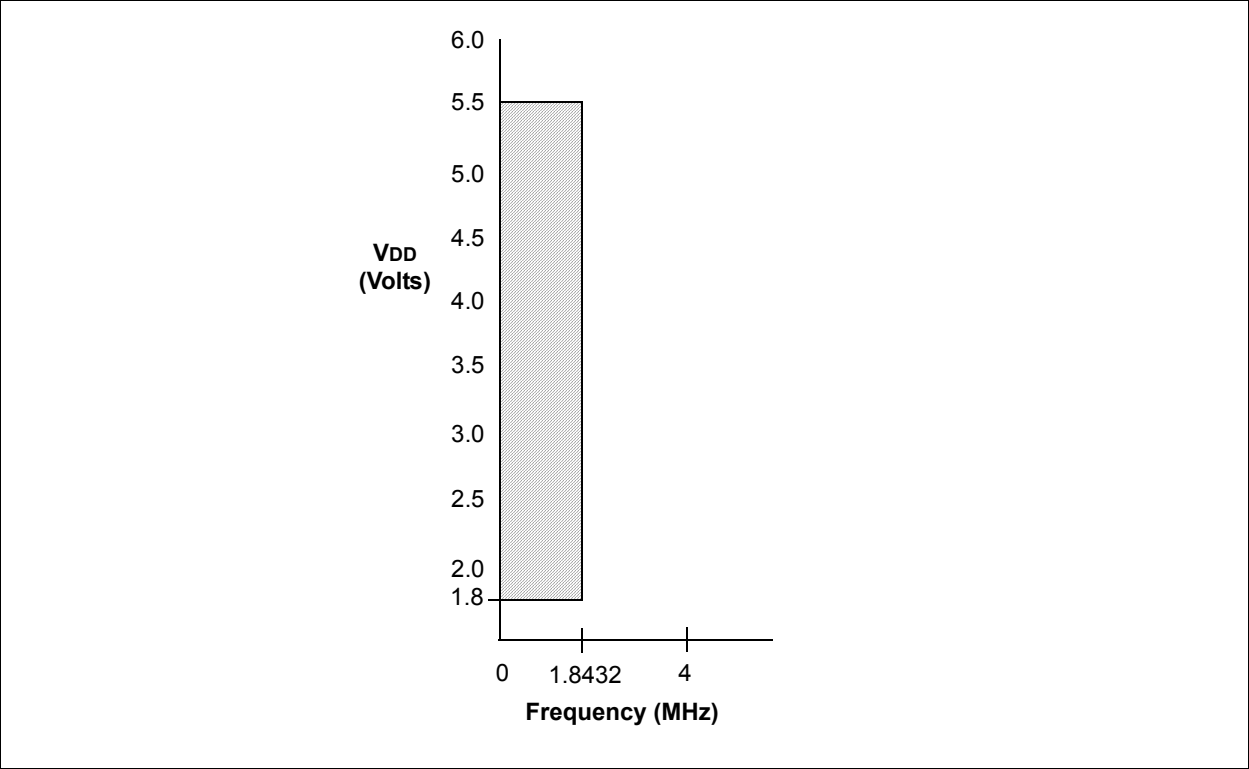

4.1 DC Characteristics

DC Characteristics			Standard Operating Conditions (unless otherwise specified) Operating Temperature: $-40^{\circ}\text{C} \leq T_A \leq +125^{\circ}\text{C}$ (Extended)					
Param. No.	Sym	Characteristic	Min	Typ ⁽¹⁾	Max	Units	Conditions	
D001	VDD	Supply Voltage	1.8	—	5.5	V	See Figure 4-1	
D010	IDD	Supply Current ⁽²⁾	—	0.1	1	mA	FOSC = 1.8432 MHz, VDD = 5.5V (TX = H, RXIR = H)	
			—	—	—	—	—	Transmitter (TX = L, RXIR = H)
			—	—	300	μA	FOSC = 1.8432 MHz, VDD = 1.8V ⁽⁴⁾	
			—	—	1	mA	FOSC = 1.8432 MHz, VDD = 5.5V	
			—	—	—	—	—	Receiver (RXIR = L, TX = H)
			—	—	500	μA	FOSC = 1.8432 MHz, VDD = 1.8V ⁽⁴⁾	
D020	IPD	Device Disabled Current ⁽³⁾	—	—	2	μA	VDD = 1.8V ⁽⁴⁾	
			—	—	4	μA	VDD = 5.5V	

Note 1: Data in the Typical (“Typ”) column is based on characterization results at +25°C. This data is for design guidance only and is not tested.

2: The supply current is mainly a function of the operating voltage and frequency. Pin loading, pin rate and temperature have an impact on the current consumption.

a) The test conditions for all IDD measurements are:

16XCLK = external square wave, from rail-to-rail; TX = VSS, RXIR = VSS, $\overline{\text{RESET}} = \text{VDD}$.

3: The device disable current is mainly a function of the operating voltage. Temperature also has an impact on the current consumption. When the device is disabled ($\overline{\text{RESET}} = \text{VSS}$). The test conditions for all IDD measurements are:

16XCLK = external square wave, from rail-to-rail; TX = VSS, RXIR = VDD, $\overline{\text{RESET}} = \text{VSS}$; The output pins are driving a high or low level into infinite impedance.

4: These parameters (shaded) are characterized but are not tested. These values should be used for design guidance only.

MCP2122

DC Characteristics (Continued)

DC CHARACTERISTICS			Standard Operating Conditions (unless otherwise specified) Operating temperature $-40^{\circ}\text{C} \leq T_A \leq +125^{\circ}\text{C}$ (extended) Operating voltage V_{DD} range as described in DC spec, Section 4.1 “DC Characteristics” .				
Param No.	Sym	Characteristic	Min	Typ ⁽¹⁾	Max	Units	Conditions
D031 D032 D033	V _{IL}	Input Low-Voltage Input pins					
		TX, RXIR	V _{SS}	—	0.2 V _{DD}	V	
		$\overline{\text{RESET}}$	V _{SS}	—	0.2 V _{DD}	V	
D033		16XCLK	V _{SS}	—	0.2 V _{DD}	V	
D041 D042 D043	V _{IH}	Input High-Voltage Input pins					
		TX, RXIR	0.8 V _{DD}	—	V _{DD}	V	
		$\overline{\text{RESET}}$	0.8 V _{DD}	—	V _{DD}	V	
D043		16XCLK	0.8 V _{DD}	—	V _{DD}	V	
D060A D061 D060B	I _{IL}	Input Leakage Current ^(2, 3) TX and 16XCLK	—	—	±1	μA	V _{SS} ≤ V _{PIN} ≤ V _{DD} , Pin at high-impedance
		$\overline{\text{RESET}}$	—	—	±1	μA	V _{SS} ≤ V _{PIN} ≤ V _{DD}
	D060B	I _{IH}	RXIR	—	—	±1	μA

Note 1: Data in the Typical (“Typ”) column is based on characterization results at +25°C. This data is for design guidance only and is not tested.

2: The leakage current on the $\overline{\text{RESET}}$ pin is strongly dependent on the applied voltage level. The specified levels represent normal operating conditions. Higher leakage current may be measured at different input voltages.

3: Negative current is defined as coming out of the pin.

DC Characteristics (Continued)

DC CHARACTERISTICS			Standard Operating Conditions (unless otherwise specified) Operating temperature: $-40^{\circ}\text{C} \leq T_A \leq +125^{\circ}\text{C}$ (Extended) Operating voltage V_{DD} range as described in DC spec, Section 4.1 “DC Characteristics”.				
Param No.	Sym	Characteristic	Min	Typ ⁽¹⁾	Max	Units	Conditions
D080B D081	VOL	Output Low-Voltage					
		RX	—	—	0.6	V	$I_{OL} = 2\text{ mA}, V_{DD} = 1.8\text{V}$
		TXIR	—	—	0.6	V	$I_{OL} = 2\text{ mA}, V_{DD} = 1.8\text{V}$
D090B D091	VOH	Output High-Voltage					
		RX ⁽²⁾	$V_{DD} - 0.7$	—	—	V	$I_{OH} = -0.8\text{ mA}, V_{DD} = 1.8\text{V}$
		TXIR ⁽²⁾	$V_{DD} - 0.7$	—	—	V	$I_{OH} = -0.8\text{ mA}, V_{DD} = 1.8\text{V}$
		Capacitive Loading Specs on Output Pins					
D101A	COUT	All Output pins	—	—	50	pF	$T_A = +25^{\circ}\text{C}, F_C = 1.0\text{ MHz}$
D101B	CIN	All Input pins	—	7	—	pF	

Note 1: Data in the Typical (“Typ”) column is based on characterization results at $+25^{\circ}\text{C}$. This data is for design guidance only and is not tested.

2: Negative current is defined as coming out of the pin.

MCP2122

4.2 Timing Parameter Symbolology and Load Conditions

The timing parameter symbols have been created following one of the following formats:

4.2.1 TIMING CONDITIONS

The temperature and voltages specified in [Table 4-2](#) apply to all timing specifications, unless otherwise noted. [Figure 4-2](#) specifies the load conditions for the timing specifications.

TABLE 4-1: SYMBOLOGY

1. TppS2ppS		2. TppS	
T			
F	Frequency	T	Time
E	Error		
Lowercase letters (pp) and their meanings:			
pp			
io	Input or Output pin	xclk	Oscillator
rx	Receive	tx	Transmit
bitclk	RX/TX BITCLK	RST	Reset
Uppercase letters and their meanings:			
S			
F	Fall	P	Period
H	High	R	Rise
I	Invalid (Hi-impedance)	V	Valid
L	Low	Z	High-impedance

TABLE 4-2: AC TEMPERATURE AND VOLTAGE SPECIFICATIONS

AC CHARACTERISTICS	Standard Operating Conditions (unless otherwise stated) Operating temperature: $-40^{\circ}\text{C} \leq T_A \leq +125^{\circ}\text{C}$ (Extended) Operating voltage V_{DD} range as described in DC spec, Section 4.1 "DC Characteristics" .
---------------------------	---

FIGURE 4-2: LOAD CONDITIONS FOR DEVICE TIMING SPECIFICATIONS

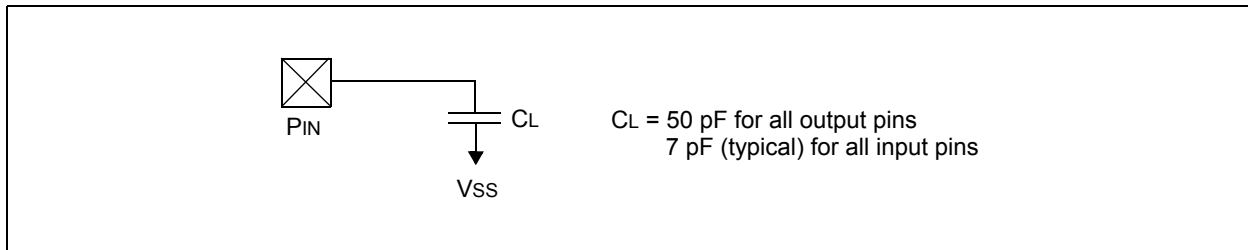

4.3 Timing Diagrams and Specifications

FIGURE 4-3: EXTERNAL CLOCK TIMING

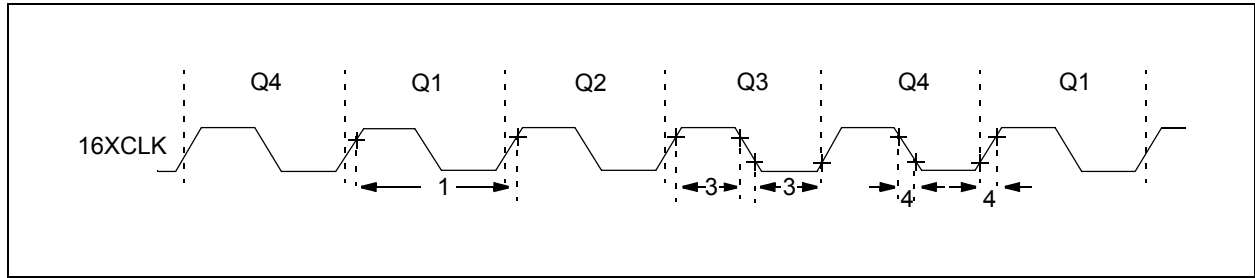

TABLE 4-3: EXTERNAL CLOCK TIMING REQUIREMENTS

AC Characteristics			Standard Operating Conditions (unless otherwise specified) Operating Temperature: $-40^{\circ}\text{C} \leq T_A \leq +125^{\circ}\text{C}$ (Extended) Operating Voltage V_{DD} range is described in Section 4.1 “DC Characteristics”				
Param. No.	Sym	Characteristic	Min	Typ ⁽¹⁾	Max	Units	Conditions
1	TXCLK	External 16XCLK Period ^(2, 3)	542.5	—	—	ns	
1A	FXCLK	External 16XCLK Frequency ^(2, 3)	DC	—	1.8432	MHz	
1C	EXCLK	Clock Error ^(4, 5)	—	—	± 2	%	Note 5
3	TXCLKL, TXCLKH	Clock in (16XCLK) Low or High Time	50	—	—	ns	
4	TXCLKR, TXCLKF	Clock in (16XCLK) Rise or Fall Time ⁽⁵⁾	—	—	7.5	ns	Note 5

Note 1: Data in the Typical (“Typ”) column is at 5V, +25°C, unless otherwise stated. These parameters are for design guidance only and are not tested.

- 2:** All specified values are based on characterization data for that particular oscillator type under standard operating conditions with the device executing code. Exceeding these specified limits may result in an unstable oscillator operation and/or higher than expected current consumption. When an external clock input is used, the “max” cycle time limit is “DC” (no clock) for all devices.
- 3:** A duty cycle of no more than 60/40 (High-Time/Low-Time or Low-Time/High-Time) is recommended for external clock inputs.
- 4:** This is the clock error from the desired clock frequency. The total system clock error includes the error from the transmitter and the error of receiver (from the desired clock frequency). If the transmitter is 2% fast from the target frequency, and the receiver is 2% slow from the target frequency, the total error is 4%.
- 5:** These parameters (shaded) are characterized but are not tested. These values should be used for design guidance only.

MCP2122

FIGURE 4-4: I/O WAVEFORM

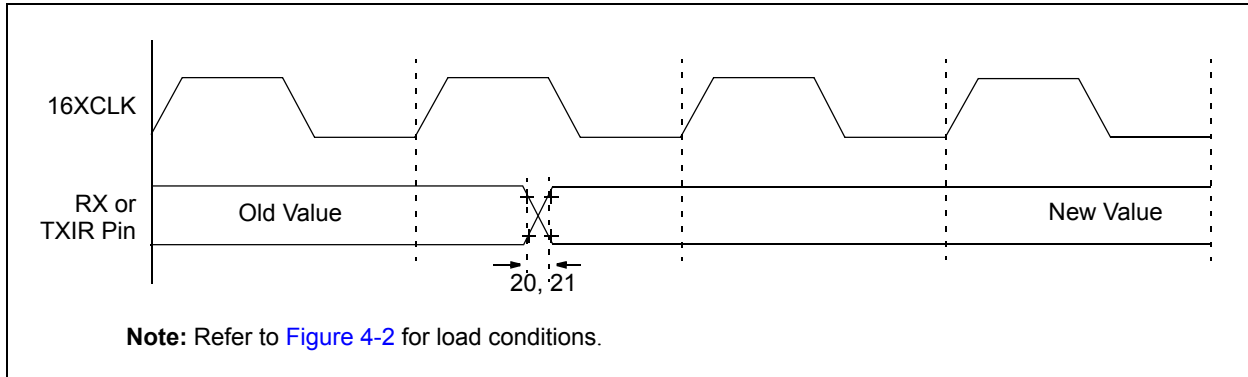

TABLE 4-4: I/O TIMING REQUIREMENTS

AC Characteristics		Standard Operating Conditions (unless otherwise specified) Operating Temperature: $-40^{\circ}\text{C} \leq T_A \leq +125^{\circ}\text{C}$ (Extended) Operating Voltage V_{DD} range is described in Section 4.1 "DC Characteristics"					
Param. No.	Sym	Characteristic	Min	Typ ⁽¹⁾	Max	Units	Conditions
20A	ToR	RX pin rise time ^(2, 3)	—	10	25	ns	$V_{DD} \geq 2.7\text{V}$ (Note 3)
20B			—	10	60	ns	$V_{DD} = 1.8\text{V}$ (Note 3)
20C		TXIR pin rise time ^(2, 3)	—	10	25	ns	$V_{DD} \geq 2.7\text{V}$ (Note 3)
20D			—	10	60	ns	$V_{DD} = 1.8\text{V}$ (Note 3)
21A	ToF	RX pin fall time ^(2, 3)	—	10	35	ns	Note 3
21C		TXIR pin fall time ^(2, 3)	—	10	25	ns	Note 3

Note 1: Data in the Typical ("Typ") column is at 5V, +25°C unless otherwise stated. These parameters are for design guidance only and are not tested.

2: See Figure 4-2 for loading conditions.

3: These parameters (shaded) are characterized but are not tested. These values should be used for design guidance only.

FIGURE 4-5: $\overline{\text{RESET}}$ AND DEVICE RESET TIMER TIMING

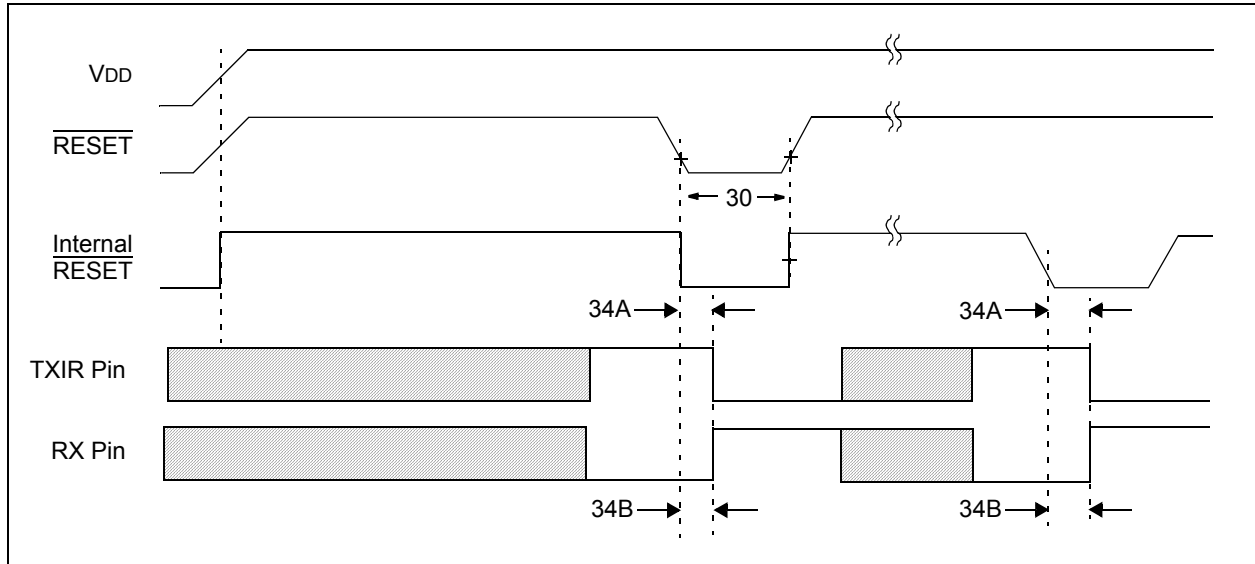

TABLE 4-5: $\overline{\text{RESET}}$ AND DEVICE RESET TIMER REQUIREMENTS

AC Characteristics			Standard Operating Conditions (unless otherwise specified) Operating Temperature: $-40^{\circ}\text{C} \leq T_A \leq +125^{\circ}\text{C}$ (Extended) Operating Voltage V_{DD} range is described in Section 4.1 “DC Characteristics”.				
Param. No.	Sym	Characteristic	Min	Typ ⁽¹⁾	Max	Units	Conditions
30	TRSTL	$\overline{\text{RESET}}$ Pulse Width (low)	2000	—	—	ns	$V_{DD} = 5.0\text{ V}$
34A	ToD	Default output state of TXIR pin from $\overline{\text{RESET}}$ Low	—	—	2	μs	
34B	ToD	Default output state of RX pins from $\overline{\text{RESET}}$ Low	—	—	2	μs	

Note 1: Data in the Typical (“Typ”) column is at 5V, +25°C unless otherwise stated. These parameters are for design guidance only and are not tested.

MCP2122

FIGURE 4-6: TX AND TXIR WAVEFORMS

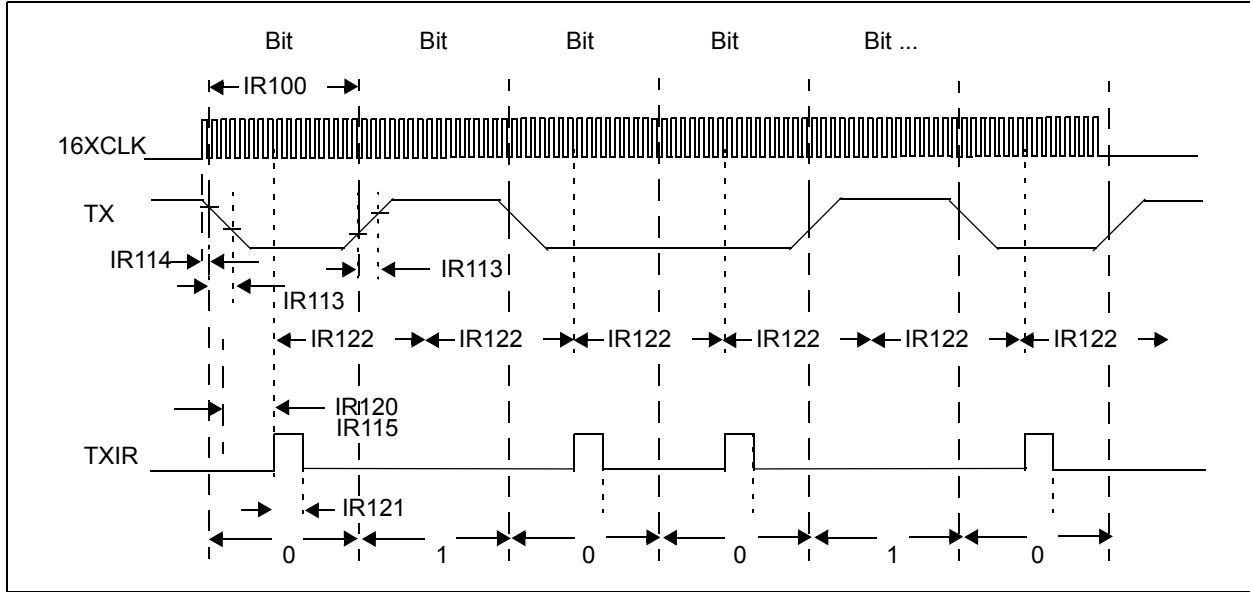

TABLE 4-6: TX AND TXIR REQUIREMENTS

AC Characteristics			Standard Operating Conditions (unless otherwise specified) Operating Temperature: $-40^{\circ}\text{C} \leq T_A \leq +125^{\circ}\text{C}$ (Extended) Operating Voltage V_{DD} range is described in Section 4.1 “DC Characteristics” .				
Param. No.	Sym	Characteristic	Min	Typ ⁽¹⁾	Max	Units	Conditions
IR100A	TTXBIT	Transmit Baud Rate	—	16	—	TXCLK	
IR100B	TTXIRBIT	Transmit Baud Rate	16	—	16	TXCLK	
IR102A	ETXBIT	Host UART TX Error	—	—	± 2	%	Note 2, 3
IR102B	ETXIRBIT	TXIR Error from 16XCLK	—	0	—	%	Note 2, 4
IR113	TTXRF	TX pin rise time and fall time	—	—	25	ns	Note 2
IR114	TTPDIRJ	16XCLK to TX jitter	—	—	1	TXCLK	Note 2
IR120	TTL2TXIRH	TX falling edge (\downarrow) to TXIR rising edge (\uparrow) ⁽¹⁾	7	—	8	TXCLK	
IR121A	TTXIRPW	TXIR pulse width	3	—	3	TXCLK	At 115200 baud
IR121B			1.41	3.5	5	μs	At 9600 baud (Note 5)
IR122	TTXIRP	TXIR bit period ⁽¹⁾	—	16	—	TXCLK	
IR123	TTXIRRF	TXIR pin rise time and fall time	—	—	10	ns	50 pF load (Note 2)

Note 1: Data in the Typical (“Typ”) column is at 5V, +25°C, unless otherwise stated. These parameters are for design guidance only and are not tested.

2: These parameters (shaded) are characterized but are not tested. These values should be used for design guidance only.

3: The TX pin operation may be asynchronous to the 16XCLK pin. This is the error from the desired baud rate for the system.

4: The TXIR pin operation is synchronous to the 16XCLK pin. Any error present on the 16XCLK pin ([Parameter 1C](#)) will be refelected on the TXIR pin.

5: This specification is not tested. This value is from the design target.

FIGURE 4-7: 16XCLK AND THE TX AND TXIR WAVEFORMS

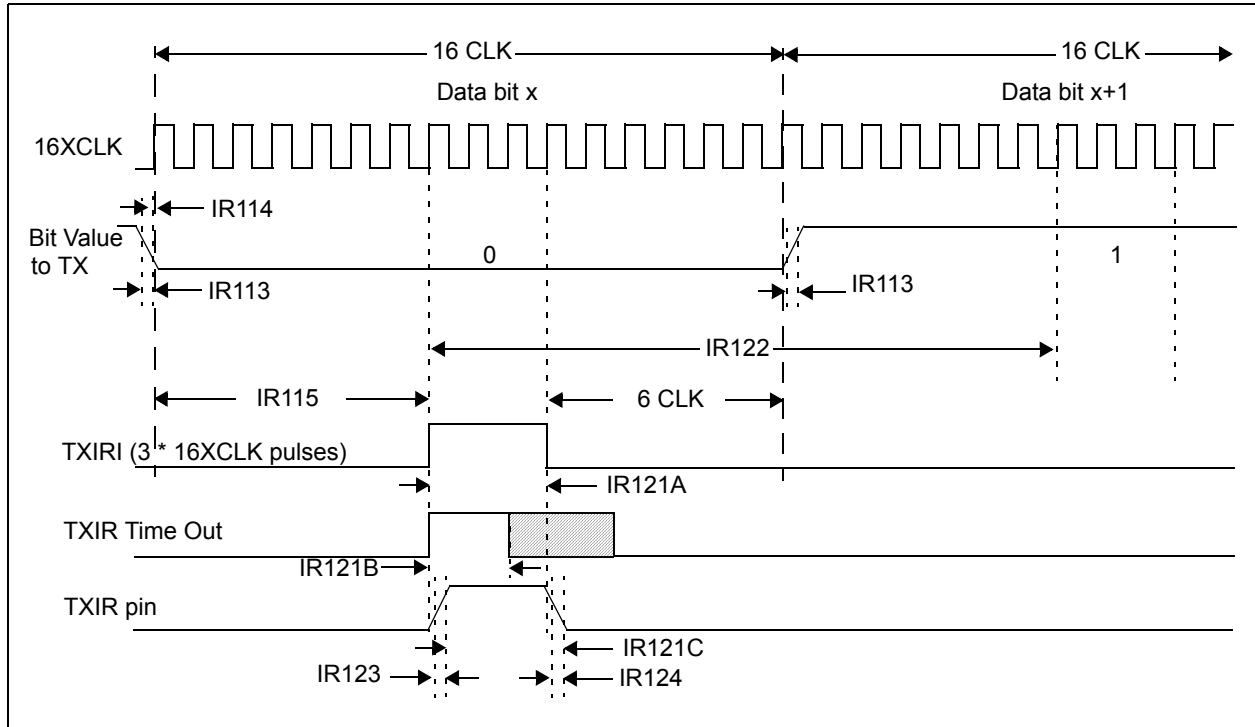

TABLE 4-7: TX AND TXIR REQUIREMENTS

AC Characteristics			Standard Operating Conditions (unless otherwise specified) Operating Temperature: $-40^{\circ}\text{C} \leq T_A \leq +125^{\circ}\text{C}$ (Extended) Operating Voltage V_{DD} range is described in Section 4.1 "DC Characteristics".				
Param. No.	Symbol	Characteristic	Min	Typ ⁽¹⁾	Max	Units	Conditions
IR113	T _{TXRF}	TX pin rise time and fall time	—	—	25	ns	Note 2
IR114	T _{TXJ}	TX to 16XCLK jitter	—	—	1	TXCLK	Note 2
IR120	T _{TXL2TXIRH}	TX falling edge (↓) to TXIR rising edge (↑) ⁽¹⁾	7	—	8	TXCLK	
IR121A IR121B	T _{TXIRPW}	TXIR pulse width	Smaller of 3 1.41	— 3.5	Smaller of 3 5	TXCLK μs	At 115200 baud At 9600 baud (Note 3)
IR122	T _{TXIRP}	TXIR bit period	—	16	—	TXCLK	
20C 20D	T _{TXIRR}	TXIR pin rise time	—	10	25 60	ns	$V_{DD} \geq 2.7\text{V}$ (Note 2) $V_{DD} = 1.8\text{V}$ (Note 2)
21C	T _{TXIRF}	TXIR pin fall time	—	10	25	ns	Note 2

Note 1: Data in the Typical ("Typ") column is at 5V, +25°C, unless otherwise stated. These parameters are for design guidance only and are not tested.

2: These parameters (shaded) are characterized but are not tested. These values should be used for design guidance only.

3: This specification is not tested. This value is from the design target

MCP2122

FIGURE 4-8: RXIR AND RX WAVEFORMS

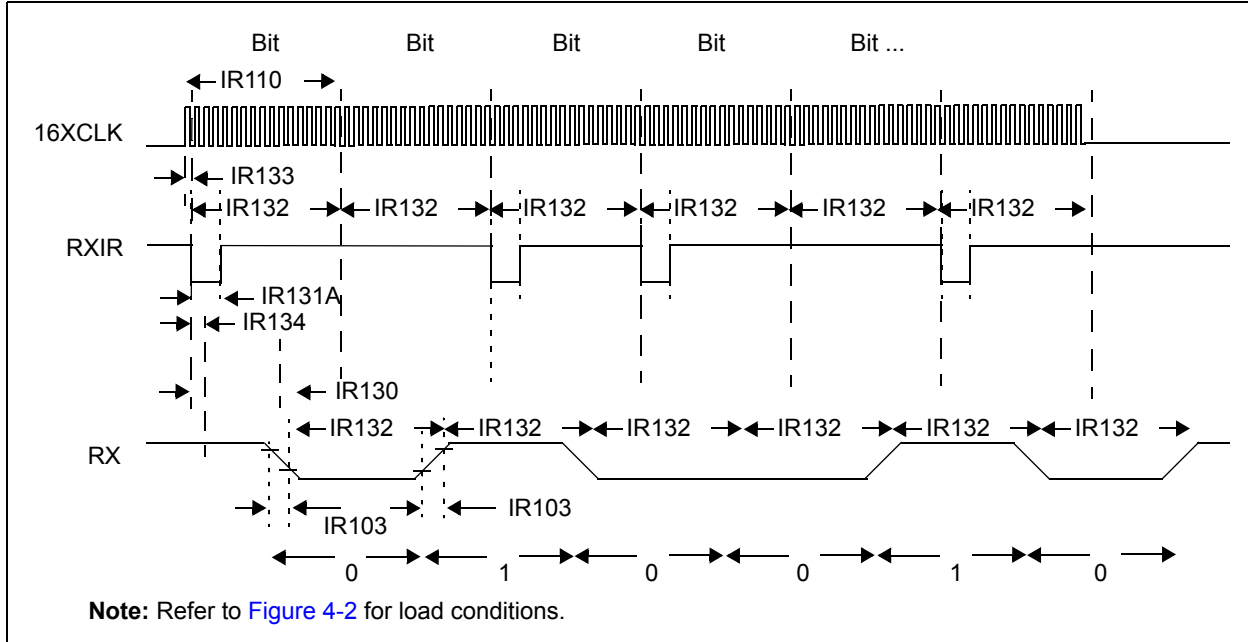

TABLE 4-8: RXIR REQUIREMENTS

AC Characteristics			Standard Operating Conditions (unless otherwise specified) Operating Temperature: $-40^{\circ}\text{C} \leq T_A \leq +125^{\circ}\text{C}$ (Extended) Operating Voltage V_{DD} range is described in Section 4.1 “DC Characteristics” .				
Param. No.	Sym	Characteristic	Min	Typ ⁽¹⁾	Max	Units	Conditions
IR101A	ERXIRBIT	RXIR Error	—	—	± 2	%	Note 2, 3
IR101B	ERXBIT	Host UART RX Error	—	0	—	%	Note 2, 4
IR103	T _{TXRF}	RX pin rise time and fall time	—	—	25	ns	
IR110	T _{RXBIT}	Receive (RX pin) Bit Rate	16	—	16	TXCLK	
IR130	T _{RXIRL2RXH}	RXIR Low AND 16XCLK edge (\downarrow or \uparrow) to RX falling edge (\downarrow)	—	4	—	TXCLK	At 115,200 baud
			—	3	—	TXCLK	At 9600 baud
IR131A	T _{RXIRPW}	RXIR pulse width	1.41	—	3 TXCLK	μs	
IR132	T _{RXIRP}	RXIR bit period ⁽¹⁾	—	16	—	TXCLK	
IR133	T _{RXIRJ}	16XCLK to RXIR jitter	—	—	1	TXCLK	Note 2
IR134	T _{RXSKW}	16XCLK to RX skew	—	—	2.5	μs	
IR135	T _{RXPDFIL}	RXIR Filter	0.7	—	1.4	μs	Note 5

Note 1: Data in the Typical (“Typ”) column is at 5V, +25°C, unless otherwise stated. These parameters are for design guidance only and are not tested.

2: These parameters (shaded) are characterized but are not tested. These values should be used for design guidance only.

3: The RXIR pin operation is asynchronous to the 16XCLK pin. This is the error from the desired baud rate for the system.

4: The RX pin operation is synchronous to the 16XCLK pin. Any error present on the 16XCLK pin (**Parameter 1C**) will be relected on the RX pin.

5: The minimum specification ensures that ALL pulses less then this pulse width are rejected, the maximum specification ensures that ALL pulses greater than this pulse width are never rejected, and pulse widths between these may or may not be rejected.

5.0 DC AND AC CHARACTERISTICS GRAPHS AND TABLES

The graphs and tables are not available at this time

MCP2122

NOTES:

6.0 PACKAGING INFORMATION

6.1 Package Marking Information

8-Lead PDIP (300 mil)

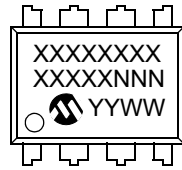

Example:

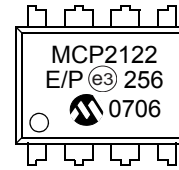

8-Lead SOIC (150 mil)

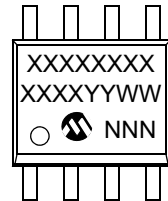

Example:

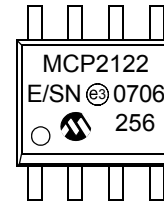

Legend:	XX...X	Customer-specific information
	Y	Year code (last digit of calendar year)
	YY	Year code (last 2 digits of calendar year)
	WW	Week code (week of January 1 is week '01')
	NNN	Alphanumeric traceability code
	(e3)	Pb-free JEDEC designator for Matte Tin (Sn)
	*	This package is Pb-free. The Pb-free JEDEC designator (e3) can be found on the outer packaging for this package.

Note: In the event the full Microchip part number cannot be marked on one line, it will be carried over to the next line, thus limiting the number of available characters for customer-specific information.

MCP2122

8-Lead Plastic Dual In-Line (P or PA) – 300 mil Body [PDIP]

Note: For the most current package drawings, please see the Microchip Packaging Specification located at <http://www.microchip.com/packages>

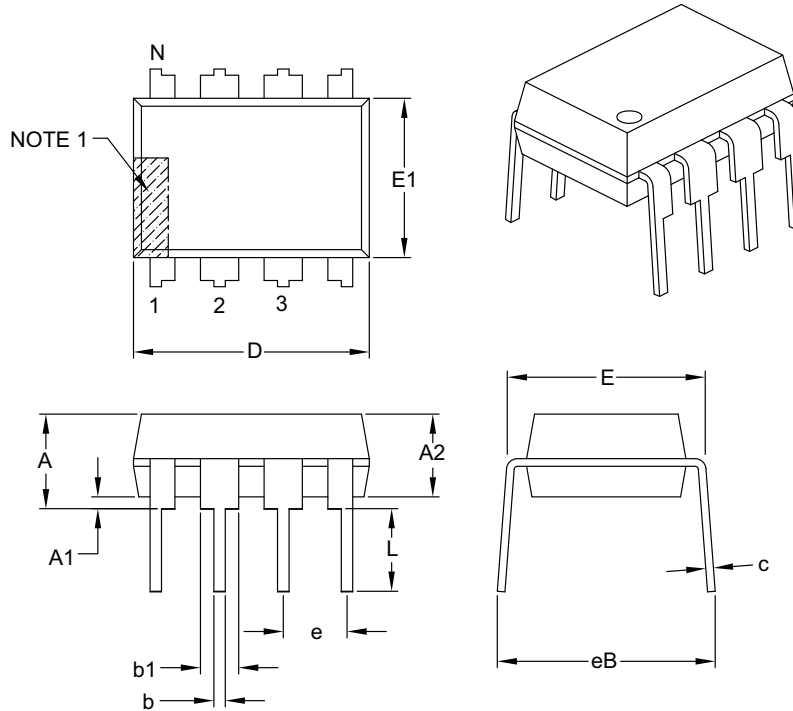

Dimension Limits	Units	INCHES		
		MIN	NOM	MAX
Number of Pins	N	8		
Pitch	e	.100 BSC		
Top to Seating Plane	A	–	–	.210
Molded Package Thickness	A2	.115	.130	.195
Base to Seating Plane	A1	.015	–	–
Shoulder to Shoulder Width	E	.290	.310	.325
Molded Package Width	E1	.240	.250	.280
Overall Length	D	.348	.365	.400
Tip to Seating Plane	L	.115	.130	.150
Lead Thickness	c	.008	.010	.015
Upper Lead Width	b1	.040	.060	.070
Lower Lead Width	b	.014	.018	.022
Overall Row Spacing §	eB	–	–	.430

Notes:

- Pin 1 visual index feature may vary, but must be located with the hatched area.
- § Significant Characteristic.
- Dimensions D and E1 do not include mold flash or protrusions. Mold flash or protrusions shall not exceed .010" per side.
- Dimensioning and tolerancing per ASME Y14.5M.

BSC: Basic Dimension. Theoretically exact value shown without tolerances.

Microchip Technology Drawing C04-018B

8-Lead Plastic Small Outline (SN or OA) – Narrow, 3.90 mm Body [SOIC]

Note: For the most current package drawings, please see the Microchip Packaging Specification located at <http://www.microchip.com/packaging>

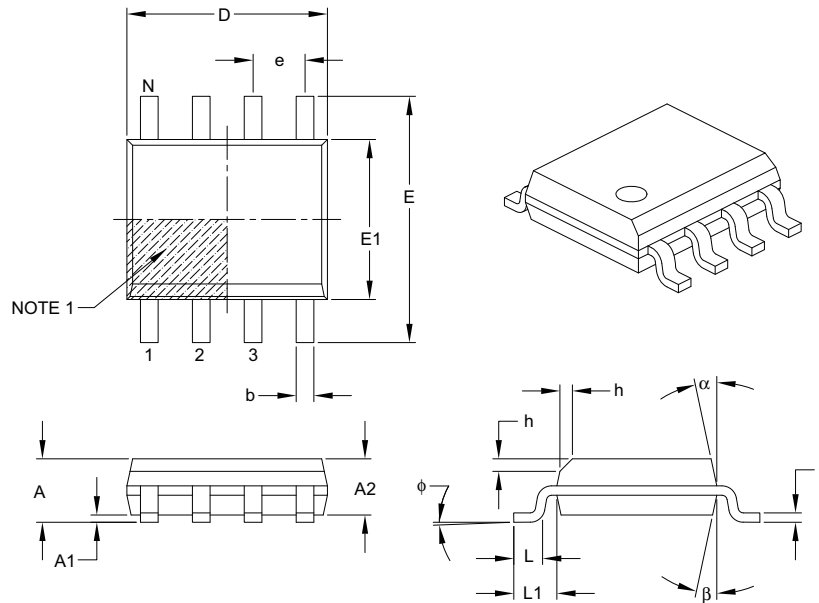

Dimension Limits	Units	MILLIMETERS		
		MIN	NOM	MAX
Number of Pins	N	8		
Pitch	e	1.27 BSC		
Overall Height	A	–	–	1.75
Molded Package Thickness	A2	1.25	–	–
Standoff §	A1	0.10	–	0.25
Overall Width	E	6.00 BSC		
Molded Package Width	E1	3.90 BSC		
Overall Length	D	4.90 BSC		
Chamfer (optional)	h	0.25	–	0.50
Foot Length	L	0.40	–	1.27
Footprint	L1	1.04 REF		
Foot Angle	ϕ	0°	–	8°
Lead Thickness	c	0.17	–	0.25
Lead Width	b	0.31	–	0.51
Mold Draft Angle Top	α	5°	–	15°
Mold Draft Angle Bottom	β	5°	–	15°

Notes:

- Pin 1 visual index feature may vary, but must be located within the hatched area.
- § Significant Characteristic.
- Dimensions D and E1 do not include mold flash or protrusions. Mold flash or protrusions shall not exceed 0.15 mm per side.
- Dimensioning and tolerancing per ASME Y14.5M.

BSC: Basic Dimension. Theoretically exact value shown without tolerances.

REF: Reference Dimension, usually without tolerance, for information purposes only.

Microchip Technology Drawing C04-057B

MCP2122

FIGURE 6-1: EMBOSSED CARRIER DIMENSIONS (12 MM TAPE)

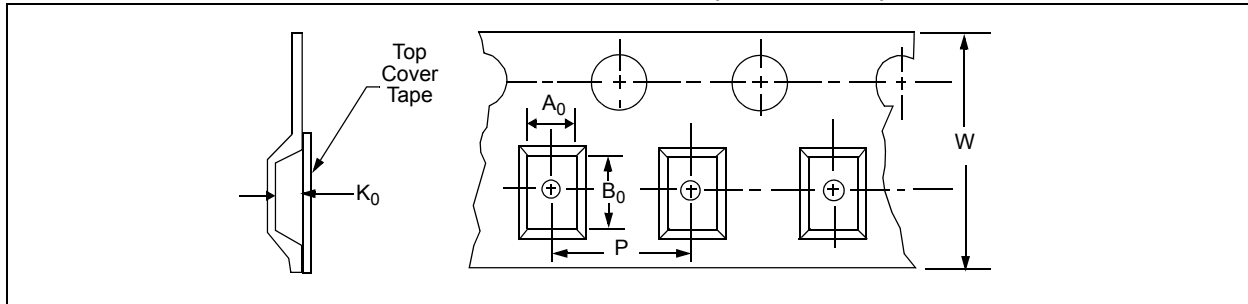
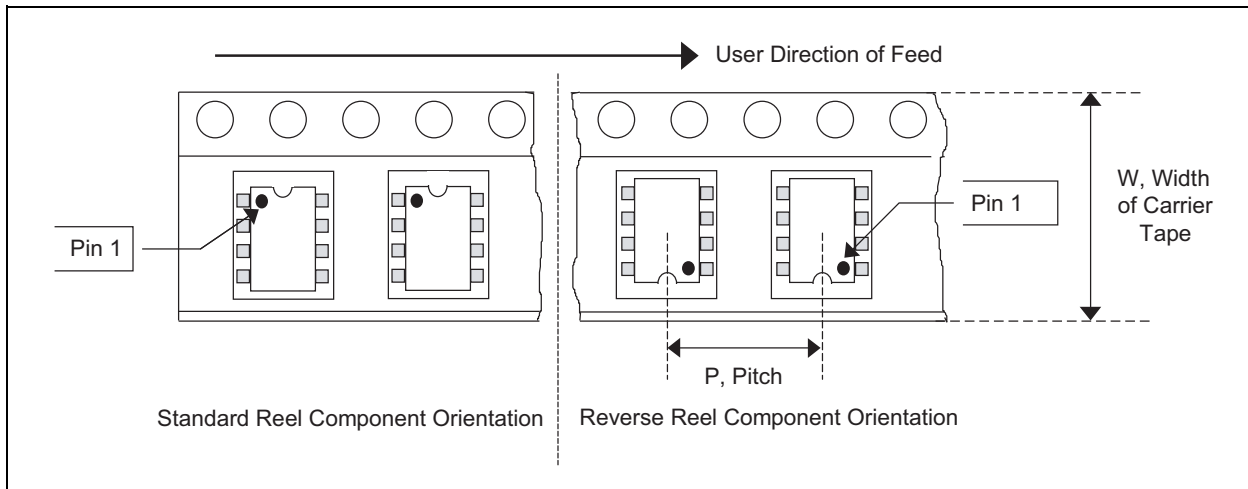

TABLE 6-1: CARRIER TAPE/CAVITY DIMENSIONS

Case Outline	Package Type	Carrier Dimensions		Cavity Dimensions			Output Quantity Units	Reel Diameter in mm
		W mm	P mm	A0 mm	B0 mm	K0 mm		
SN	SOIC .150" 8L	12	8	6.4	5.2	2.1	3300	330

FIGURE 6-2: SOIC DEVICE



APPENDIX A: REVISION HISTORY

Revision C (February 2007)

- Updated Development Tools section
- Update packaging outline drawings
- Updates Product Identification System section.

Revision B (September 2004)

- Undocumented changes

Revision A (June 2004)

- Original release of this document

MCP2122

NOTES:

PRODUCT IDENTIFICATION SYSTEM

To order or obtain information, e.g., on pricing or delivery, refer to the factory or the listed sales office.

<u>PART NO.</u>	-	X	XX
Device		Temperature Range	Package
Device		MCP2122: Infrared Encoder/Decoder MCP2122T: Infrared Encoder/Decoder, Tape and Reel	
Temperature Range	E	= -40°C to +125°C	
Package	P	= Plastic DIP (300 mil, Body), 8-lead	SN = Plastic SOIC (150 mil, Body), 8-lead

Examples:

- a) MCP2122-E/P: Extended Temperature, 8L-PDIP package
- b) MCP2122-E/SN: Extended Temperature, 8L-SOIC package
- c) MCP2122T-E/SN: Tape and Reel, Extended Temperature, 8L-SOIC package

MCP2122

NOTES:

Note the following details of the code protection feature on Microchip devices:

- Microchip products meet the specification contained in their particular Microchip Data Sheet.
- Microchip believes that its family of products is one of the most secure families of its kind on the market today, when used in the intended manner and under normal conditions.
- There are dishonest and possibly illegal methods used to breach the code protection feature. All of these methods, to our knowledge, require using the Microchip products in a manner outside the operating specifications contained in Microchip's Data Sheets. Most likely, the person doing so is engaged in theft of intellectual property.
- Microchip is willing to work with the customer who is concerned about the integrity of their code.
- Neither Microchip nor any other semiconductor manufacturer can guarantee the security of their code. Code protection does not mean that we are guaranteeing the product as “unbreakable.”

Code protection is constantly evolving. We at Microchip are committed to continuously improving the code protection features of our products. Attempts to break Microchip's code protection feature may be a violation of the Digital Millennium Copyright Act. If such acts allow unauthorized access to your software or other copyrighted work, you may have a right to sue for relief under that Act.

Information contained in this publication regarding device applications and the like is provided only for your convenience and may be superseded by updates. It is your responsibility to ensure that your application meets with your specifications. MICROCHIP MAKES NO REPRESENTATIONS OR WARRANTIES OF ANY KIND WHETHER EXPRESS OR IMPLIED, WRITTEN OR ORAL, STATUTORY OR OTHERWISE, RELATED TO THE INFORMATION, INCLUDING BUT NOT LIMITED TO ITS CONDITION, QUALITY, PERFORMANCE, MERCHANTABILITY OR FITNESS FOR PURPOSE. Microchip disclaims all liability arising from this information and its use. Use of Microchip devices in life support and/or safety applications is entirely at the buyer's risk, and the buyer agrees to defend, indemnify and hold harmless Microchip from any and all damages, claims, suits, or expenses resulting from such use. No licenses are conveyed, implicitly or otherwise, under any Microchip intellectual property rights.

Trademarks

The Microchip name and logo, the Microchip logo, Accuron, dsPIC, KEELOQ, KEELOQ logo, microID, MPLAB, PIC, PICmicro, PICSTART, PRO MATE, PowerSmart, rPIC, and SmartShunt are registered trademarks of Microchip Technology Incorporated in the U.S.A. and other countries.

AmpLab, FilterLab, Linear Active Thermistor, Migratable Memory, MXDEV, MXLAB, PS logo, SEEVAL, SmartSensor and The Embedded Control Solutions Company are registered trademarks of Microchip Technology Incorporated in the U.S.A.

Analog-for-the-Digital Age, Application Maestro, CodeGuard, dsPICDEM, dsPICDEM.net, dsPICworks, ECAN, ECONOMONITOR, FanSense, FlexROM, fuzzyLAB, In-Circuit Serial Programming, ICSP, ICEPIC, Mindi, MiWi, MPASM, MPLAB Certified logo, MPLIB, MPLINK, PICkit, PICDEM, PICDEM.net, PICLAB, PICtail, PowerCal, PowerInfo, PowerMate, PowerTool, REAL ICE, rLAB, rfPICDEM, Select Mode, Smart Serial, SmartTel, Total Endurance, UNI/O, WiperLock and ZENA are trademarks of Microchip Technology Incorporated in the U.S.A. and other countries.

SQTP is a service mark of Microchip Technology Incorporated in the U.S.A.

All other trademarks mentioned herein are property of their respective companies.

© 2007, Microchip Technology Incorporated, Printed in the U.S.A., All Rights Reserved.

 Printed on recycled paper.

QUALITY MANAGEMENT SYSTEM
CERTIFIED BY DNV
== ISO/TS 16949:2002 ==

Microchip received ISO/TS-16949:2002 certification for its worldwide headquarters, design and wafer fabrication facilities in Chandler and Tempe, Arizona, Gresham, Oregon and Mountain View, California. The Company's quality system processes and procedures are for its PIC[®] MCUs and dsPIC[®] DSCs, KEELOQ[®] code hopping devices, Serial EEPROMs, microperipherals, nonvolatile memory and analog products. In addition, Microchip's quality system for the design and manufacture of development systems is ISO 9001:2000 certified.



WORLDWIDE SALES AND SERVICE

AMERICAS

Corporate Office

2355 West Chandler Blvd.
Chandler, AZ 85224-6199
Tel: 480-792-7200
Fax: 480-792-7277
Technical Support:
<http://support.microchip.com>
Web Address:
www.microchip.com

Atlanta

Duluth, GA
Tel: 678-957-9614
Fax: 678-957-1455

Boston

Westborough, MA
Tel: 774-760-0087
Fax: 774-760-0088

Chicago

Itasca, IL
Tel: 630-285-0071
Fax: 630-285-0075

Dallas

Addison, TX
Tel: 972-818-7423
Fax: 972-818-2924

Detroit

Farmington Hills, MI
Tel: 248-538-2250
Fax: 248-538-2260

Kokomo

Kokomo, IN
Tel: 765-864-8360
Fax: 765-864-8387

Los Angeles

Mission Viejo, CA
Tel: 949-462-9523
Fax: 949-462-9608

Santa Clara

Santa Clara, CA
Tel: 408-961-6444
Fax: 408-961-6445

Toronto

Mississauga, Ontario,
Canada
Tel: 905-673-0699
Fax: 905-673-6509

ASIA/PACIFIC

Asia Pacific Office

Suites 3707-14, 37th Floor
Tower 6, The Gateway
Harbour City, Kowloon
Hong Kong
Tel: 852-2401-1200
Fax: 852-2401-3431

Australia - Sydney

Tel: 61-2-9868-6733
Fax: 61-2-9868-6755

China - Beijing

Tel: 86-10-8528-2100
Fax: 86-10-8528-2104

China - Chengdu

Tel: 86-28-8665-5511
Fax: 86-28-8665-7889

China - Fuzhou

Tel: 86-591-8750-3506
Fax: 86-591-8750-3521

China - Hong Kong SAR

Tel: 852-2401-1200
Fax: 852-2401-3431

China - Qingdao

Tel: 86-532-8502-7355
Fax: 86-532-8502-7205

China - Shanghai

Tel: 86-21-5407-5533
Fax: 86-21-5407-5066

China - Shenyang

Tel: 86-24-2334-2829
Fax: 86-24-2334-2393

China - Shenzhen

Tel: 86-755-8203-2660
Fax: 86-755-8203-1760

China - Shunde

Tel: 86-757-2839-5507
Fax: 86-757-2839-5571

China - Wuhan

Tel: 86-27-5980-5300
Fax: 86-27-5980-5118

China - Xian

Tel: 86-29-8833-7250
Fax: 86-29-8833-7256

ASIA/PACIFIC

India - Bangalore

Tel: 91-80-4182-8400
Fax: 91-80-4182-8422

India - New Delhi

Tel: 91-11-4160-8631
Fax: 91-11-4160-8632

India - Pune

Tel: 91-20-2566-1512
Fax: 91-20-2566-1513

Japan - Yokohama

Tel: 81-45-471-6166
Fax: 81-45-471-6122

Korea - Gumi

Tel: 82-54-473-4301
Fax: 82-54-473-4302

Korea - Seoul

Tel: 82-2-554-7200
Fax: 82-2-558-5932 or
82-2-558-5934

Malaysia - Penang

Tel: 60-4-646-8870
Fax: 60-4-646-5086

Philippines - Manila

Tel: 63-2-634-9065
Fax: 63-2-634-9069

Singapore

Tel: 65-6334-8870
Fax: 65-6334-8850

Taiwan - Hsin Chu

Tel: 886-3-572-9526
Fax: 886-3-572-6459

Taiwan - Kaohsiung

Tel: 886-7-536-4818
Fax: 886-7-536-4803

Taiwan - Taipei

Tel: 886-2-2500-6610
Fax: 886-2-2508-0102

Thailand - Bangkok

Tel: 66-2-694-1351
Fax: 66-2-694-1350

EUROPE

Austria - Wels

Tel: 43-7242-2244-39
Fax: 43-7242-2244-393

Denmark - Copenhagen

Tel: 45-4450-2828
Fax: 45-4485-2829

France - Paris

Tel: 33-1-69-53-63-20
Fax: 33-1-69-30-90-79

Germany - Munich

Tel: 49-89-627-144-0
Fax: 49-89-627-144-44

Italy - Milan

Tel: 39-0331-742611
Fax: 39-0331-466781

Netherlands - Drunen

Tel: 31-416-690399
Fax: 31-416-690340

Spain - Madrid

Tel: 34-91-708-08-90
Fax: 34-91-708-08-91

UK - Wokingham

Tel: 44-118-921-5869
Fax: 44-118-921-5820

12/08/06