

QUAD, ECL-INTERFACED FIXED DELAY LINE (SERIES MDU14)



FEATURES

- Four independent delay lines
- Fits 24-pin (400mil) DIP socket
- Auto-insertable
- Input & outputs fully 100K-ECL interfaced & buffered

PACKAGES

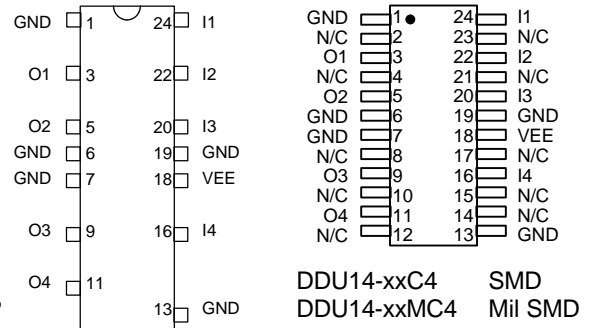

FUNCTIONAL DESCRIPTION

The MDU14-series device is a 4-in-1 digitally buffered delay line. The signal inputs (I1-I4) are reproduced at the outputs (O1-O4), shifted in time by an amount determined by the device dash number (See Table). The delay lines function completely independently of each other.

PIN DESCRIPTIONS

- I1-I4 Signal Inputs
- O1-O4 Signal Outputs
- VEE -5 Volts
- GND Ground

SERIES SPECIFICATIONS

- **Minimum input pulse width:** 40% of total delay
- **Output rise time:** 2ns typical
- **Supply voltage:** -5VDC \pm 5%
- **Power dissipation:** 500mw typical (no load)
- **Operating temperature:** 0° to 85° C
- **Temp. coefficient of total delay:** 100 PPM/°C

DASH NUMBER SPECIFICATIONS

Part Number	Total Delay (ns)
MDU14-2	2.0 \pm 1.0
MDU14-2.5	2.5 \pm 1.0
MDU14-3	3.0 \pm 1.0
MDU14-4	4.0 \pm 1.0
MDU14-5	5.0 \pm 1.0
MDU14-6	6.0 \pm 1.0
MDU14-7	7.0 \pm 1.0
MDU14-8	8.0 \pm 1.0
MDU14-9	9.0 \pm 1.0
MDU14-10	10.0 \pm 1.0
MDU14-12.5	12.5 \pm 1.0
MDU14-15	15.0 \pm 1.0
MDU14-20	20.0 \pm 1.0
MDU14-25	25.0 \pm 1.2

NOTE: Any dash number between 2 and 25 not shown is also available.

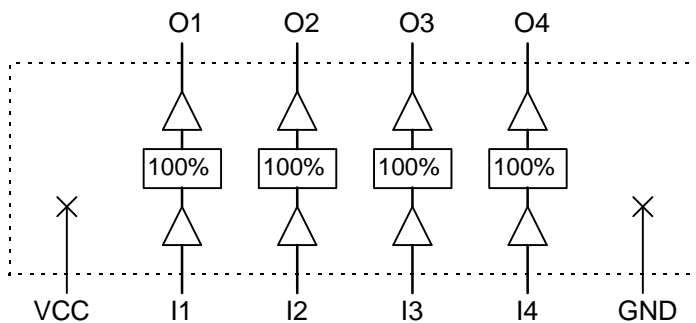

Functional block diagram

APPLICATION NOTES

HIGH FREQUENCY RESPONSE

The MDU14 tolerances are guaranteed for input pulse widths and periods greater than those specified in the test conditions. Although the device will function properly for pulse widths as small as 40% of the total delay and periods as small as 80% of the total delay (for a symmetric input), the delays may deviate from their values at low frequency. However, for a given input condition, the deviation will be repeatable from pulse to pulse. Contact technical support at Data

Delay Devices if your application requires device testing at a specific input condition.

POWER SUPPLY BYPASSING

The MDU14 relies on a stable power supply to produce repeatable delays within the stated tolerances. A 0.1uf capacitor from VEE to GND, located as close as possible to the VEE pin, is recommended. A wide VEE trace and a clean ground plane should be used.

DEVICE SPECIFICATIONS

TABLE 1: ABSOLUTE MAXIMUM RATINGS

PARAMETER	SYMBOL	MIN	MAX	UNITS	NOTES
DC Supply Voltage	V_{EE}	-7.0	0.3	V	
Input Pin Voltage	V_{IN}	$V_{EE} - 0.3$	0.3	V	
Storage Temperature	T_{STRG}	-55	150	C	
Lead Temperature	T_{LEAD}		300	C	10 sec

TABLE 2: DC ELECTRICAL CHARACTERISTICS
(0C to 85C)

PARAMETER	SYMBOL	MIN	TYP	MAX	UNITS	NOTES
High Level Output Voltage	V_{OH}	-1.025		-0.880	V	$V_{IH} = \text{MAX}, 50\Omega \text{ to } -2V$
Low Level Output Voltage	V_{OL}	-1.810		-1.620	V	$V_{IL} = \text{MIN}, 50\Omega \text{ to } -2V$
High Level Input Voltage	V_{IH}	-1.165		-0.880	V	
Low Level Input Voltage	V_{IL}	-1.810		-1.475	V	
High Level Input Current	I_{IH}			340	μA	$V_{IH} = \text{MAX}$
Low Level Input Current	I_{IL}	0.5			μA	$V_{IL} = \text{MIN}$

PACKAGE DIMENSIONS

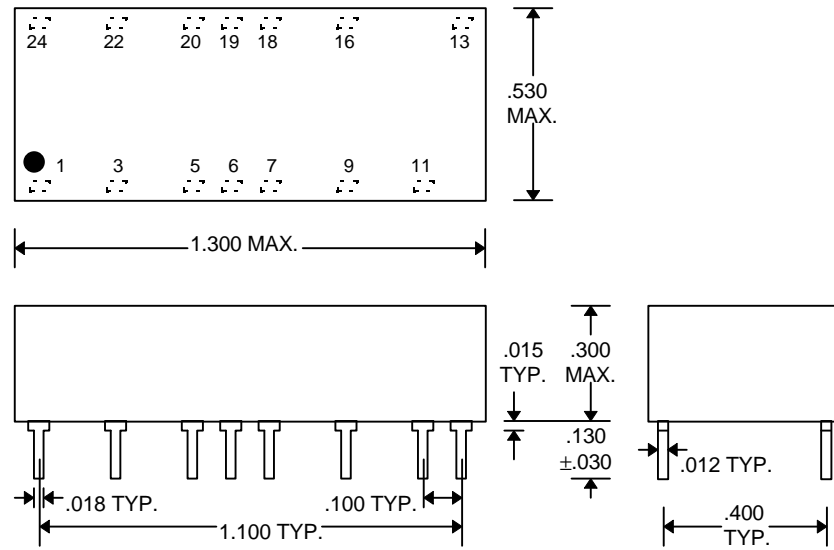

MDU14-xx (Commercial DIP)
MDU14-xxM (Military DIP)

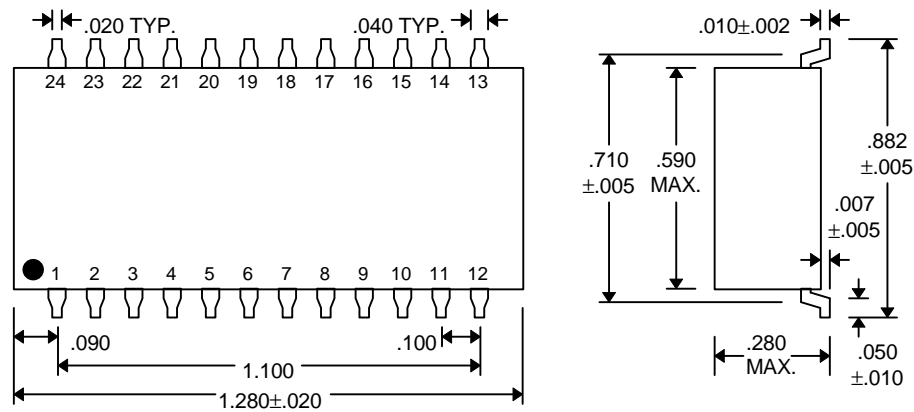

MDU14-xxC4 (Commercial SMD)
MDU14-xxMC4 (Military SMD)

DELAY LINE AUTOMATED TESTING

TEST CONDITIONS

INPUT:

Ambient Temperature: $25^{\circ}\text{C} \pm 3^{\circ}\text{C}$
Supply Voltage (Vcc): $-5.0\text{V} \pm 0.1\text{V}$
Input Pulse: Standard 10KH ECL levels
Source Impedance: 50Ω Max.
Rise/Fall Time: 2.0 ns Max. (measured between 20% and 80%)
Pulse Width: $\text{PW}_{\text{IN}} = 1.5 \times \text{Total Delay}$
Period: $\text{PER}_{\text{IN}} = 10 \times \text{Total Delay}$

OUTPUT:

Load: 50Ω to -2V
C_{load}: $5\text{pf} \pm 10\%$
Threshold: $(V_{\text{OH}} + V_{\text{OL}}) / 2$
 (Rising & Falling)

NOTE: The above conditions are for test only and do not in any way restrict the operation of the device.

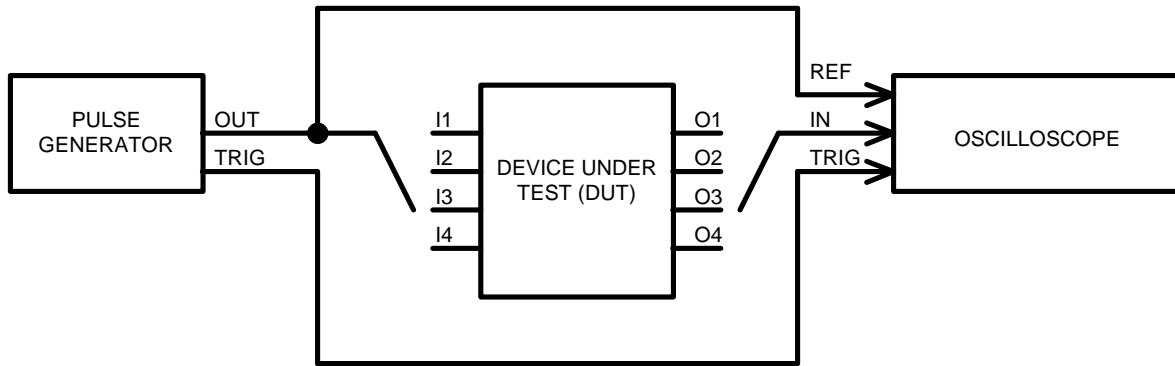

Test Setup

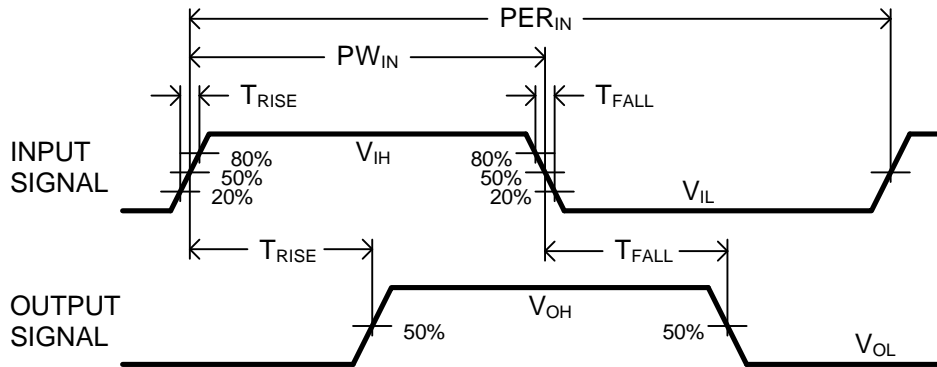

Timing Diagram For Testing