

APPROVAL SHEET

MF12F/W, MF08F/W, MF06F/W, MF04F/W

$\pm 1\%$, $\pm 0.5\%$, $\pm 0.25\%$, $\pm 0.1\%$, $\pm 0.05\%$

TC15 , TC10

Precision Thin Film Chip Resistors

Size 1206, 0805, 0603, 0402

AEC-Q200 Qualified



*Contents in this sheet are subject to change without prior notice.

FEATURE

1. SMD TaN Thin Film Resistor
2. Special passivation layer on resistive film
3. AEC-Q200 qualified
4. Products with lead free terminations meet RoHS requirements
5. Sulfur resistant (per ASTM B809-95 humid vapor test)
6. AEC-Q200 ESD rated class 1C (2 kV)
7. +/-0.02% is upon the customer request.
8. Laser trimmed to any value

APPLICATION

- Automotive Electronics
- Medical equipment
- Measuring instrument
- Industrial Equipment

DESCRIPTION

The resistors are constructed in a high grade ceramic body (aluminum oxide). Internal metal electrodes are added at each end and connected by a resistive layer that is applied to the top surface of the substrate. The composition of the resistive layer is adjusted to give the approximate resistance required and the value is trimmed to nominated value within tolerance which controlled by laser trimming of this resistive layer.

The resistive layer is covered with a protective coat. Finally, the two external end terminations are added. For environmental soldering issue, the outer layer of these end terminations is a Lead-free solder .

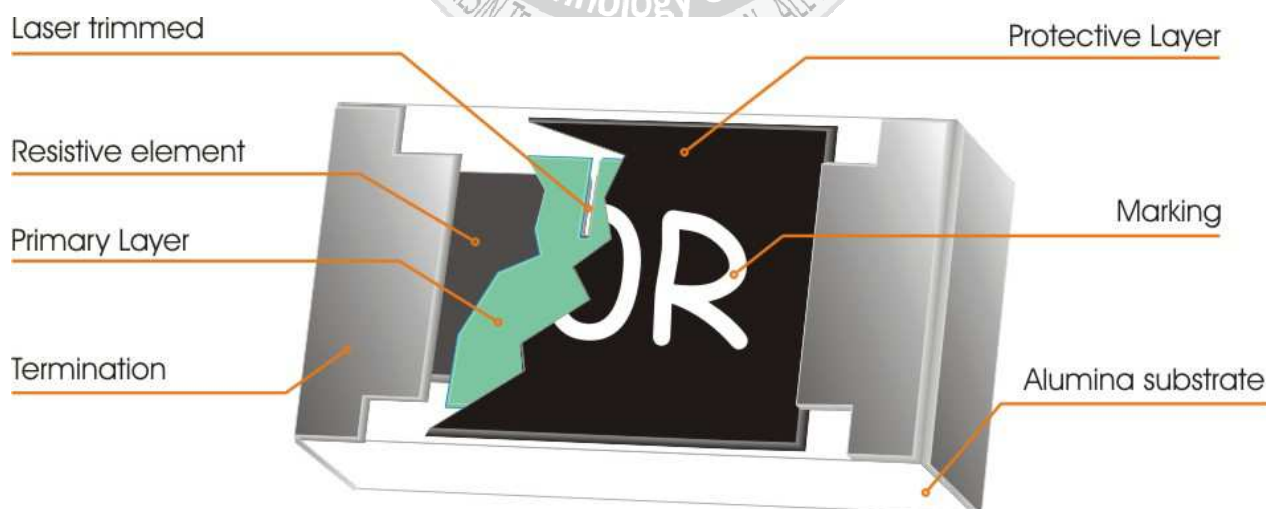

Fig 1. Construction of Chip-R MFxxF

QUICK REFERENCE DATA

Item	General Specification			
Series No.	MF12F&W	MF08F&W	MF06F&W	MF04F&W
Size code	1206 (3216)	0805 (2012)	0603 (1608)	0402 (1005)
Resistance Tolerance	±1%, ±0.5%, ±0.25%, ±0.1%, ±0.05%			
Resistance Range	10Ω ~ 1MΩ	10Ω ~ 350KΩ	40Ω ~ 130KΩ	40Ω ~ 35KΩ
TCR (ppm/°C)	+15 /+10 ppm/°C			
Max. dissipation at T _{amb} =85°C	0.4W	0.2W	0.15W	0.0625W
Max. Operation Voltage (DC or RMS)	200V	100V	75V	50V
Max. Overload Voltage (DC or RMS)	400V	200V	150V	100V
Operating Temperature Range	- 55~ +155°C			

Note :

1. This is the maximum voltage that may be continuously supplied to the resistor element, see "IEC publication 60115-8"
2. Max. Operation Voltage : So called RCWV (Rated Continuous Working Voltage) is determined by

$$RCWV = \sqrt{\text{Rated Power} \times \text{Resistance Value}} \text{ or Max. RCWV listed above, whichever is lower.}$$

DIMENSIONS:(unit:mm)

Type	MF12	MF08	MF06	MF04
L	3.10 ± 0.10	2.00 ± 0.10	1.55 ± 0.10	1.00 ± 0.10
W	1.60 ± 0.10	1.25 ± 0.10	0.80 ± 0.10	0.50 ± 0.05
A	0.40 ± 0.20	0.35 ± 0.20	0.3 ± 0.20	0.25 ± 0.15
B	0.40 ± 0.20	0.40 ± 0.20	0.30 ± 0.15	0.30 ± 0.10
t	0.60 ± 0.15	0.50 ± 0.15	0.45 ± 0.15	0.30 ± 0.10

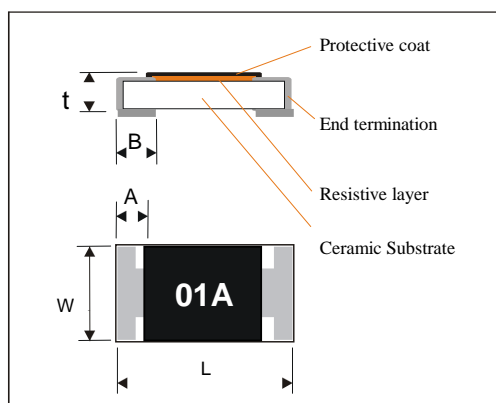

MARKING

- **3-digits marking for 0603 size**

3-digits marking ($\pm 1\%$: 0603)

Nominal resistance		Description													
1.E-24 series		As 0603 WF06U $\pm 1\%$.													
2.E-96 series		The 1st two digit codes are referring to the CODE on the table, the 3rd code is the index of resistance value : $Y=10^{-2}$, $X=10^{-1}$, $A=10^0$, $B=10^1$, $C=10^2$, $D=10^3$, $E=10^4$, $F=10^5$ EX: 17.8 Ω =25X, 178 Ω =25A, 1K78 =25B 17K8=25C, 178K=25D, 1M78=25E													
3. Remark		There is no marking for the items are not under E-24 and E-96 series													
CODE	R_value	CODE	R_value	CODE	R_value	CODE	R_value	CODE	R_value	CODE	R_value	CODE	R_value	CODE	R_value
01	100	13	133	25	178	37	237	49	316	61	422	73	562	85	750
02	102	14	137	26	182	38	243	50	324	62	432	74	576	86	768
03	105	15	140	27	187	39	249	51	332	63	442	75	590	87	787
04	107	16	143	28	191	40	255	52	340	64	453	76	604	88	806
05	110	17	147	29	196	41	261	53	348	65	464	77	619	89	825
06	113	18	150	30	200	42	267	54	357	66	475	78	634	90	845
07	115	19	154	31	205	43	274	55	365	67	487	79	649	91	866
08	118	20	158	32	210	44	280	56	374	68	499	80	665	92	887
09	121	21	162	33	215	45	287	57	383	69	511	81	681	93	909
10	124	22	165	34	221	46	294	58	392	70	523	82	698	94	931
11	127	23	169	35	226	47	301	59	402	71	536	83	715	95	953
12	130	24	174	36	232	48	309	60	412	72	549	84	732	96	976

- **4-digits marking for 1206, 0805 size**

For E24/E96 series, each resistor is marked with a four digits code on the protective coating to designate the nominal resistance value. For non E24/E96 series, no marking is applied!

Example

RESISTANCE	10 Ω	12 Ω	100 Ω	6800 Ω	47000 Ω
4-digits marking	10R0	12R0	1000	6801	4702

- **No marking code for 0402 size**

FUNCTIONAL DESCRIPTION

Product characterization

Standard values of nominal resistance are taken from the E192 & E24 series for resistors with a tolerance of $\pm 1\%$, $\pm 0.5\%$, $\pm 0.25\%$, $\pm 0.1\%$, $\pm 0.05\%$. The values of the E24/E192 series are in accordance with "IEC publication 60063".

Derating

The power that the resistor can dissipate depends on the operating temperature; see Fig.2

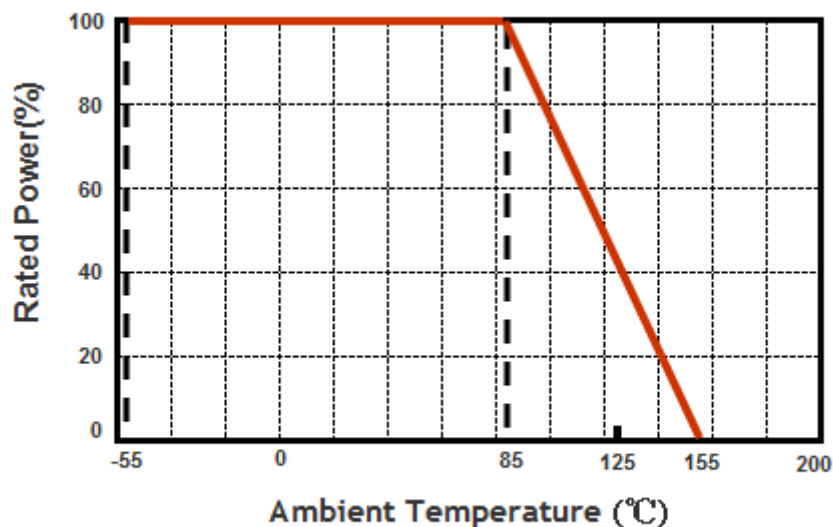

Fig.2 Maximum dissipation in percentage of rated power as a function of ambient temperature

MOUNTING

Due to their rectangular shapes and small tolerances, Surface Mountable Resistors are suitable for handling by automatic placement systems.

Chip placement can be on ceramic substrates and printed-circuit boards (PCBs).

Electrical connection to the circuit is by individual soldering condition.

The end terminations guarantee a reliable contact.

Storage and Handling Condition:

1. Products are recommended to be used up within two years. Check solderability in case shelf life extension is needed.
2. To store products with following condition:
 Temperature : 5 to 40°C
 Humidity : 20 to 70% relative humidity
3. Caution:
 - a. Don't store products in a corrosive environment such as sulfide, chloride gas, or acid. It may cause oxidation of electrode, which easily be resulted in poor soldering.
 - b. To store products on the shelf and avoid exposure to moisture.
 - c. Don't expose products to excessive shock, vibration, direct sunlight and so on.

SOLDERING CONDITION

The robust construction of chip resistors allows them to be completely immersed in a solder bath of 260°C for 10 seconds. Therefore, it is possible to mount Surface Mount Resistors on one side of a PCB and other discrete components on the reverse (mixed PCBs).

Surface Mount Resistors are tested for solderability at 235°C during 2 seconds within lead-free solder bath. The test condition for no leaching is 260°C for 30 seconds. Typical examples of soldering profile and condition that provide reliable joints without any damage are given in Fig 3. and Table 1.

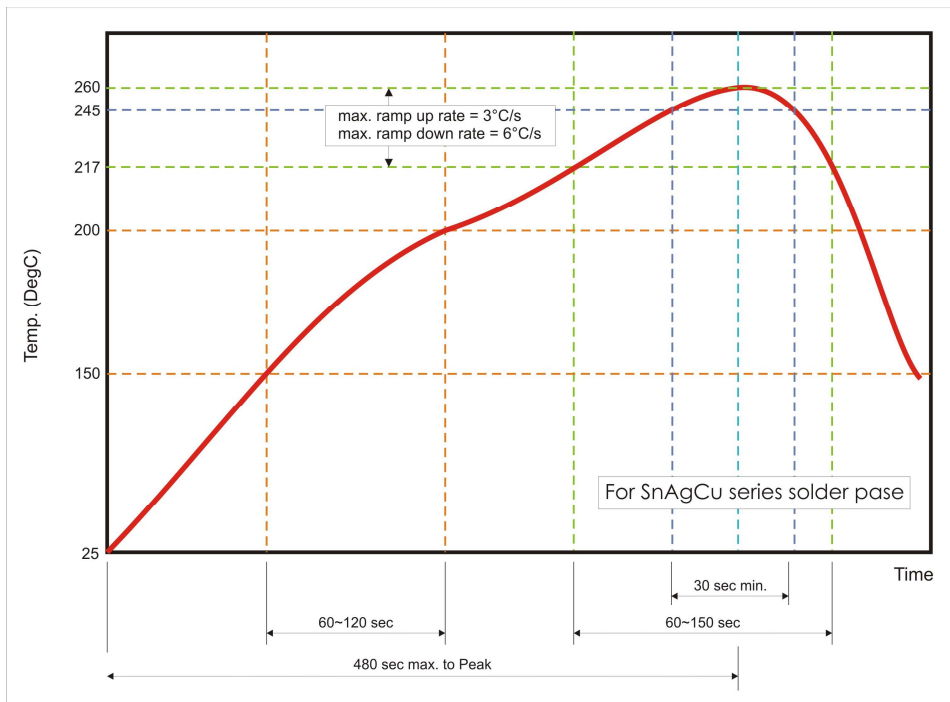

Fig. 3 Infrared soldering profile for Chip Resistors

Table 1. Infrared soldering condition for Chip Resistors

Temperature Condition	Exposure Time
Average ramp-up rate (217°C to 260°C)	Less than 3°C/second
Between 150 and 200°C	Between 60-120 seconds
> 217°C	Between 60-150 seconds
Peak Temperature	260°C +0/-5°C
Time within 245°C	Min. 30 seconds
Ramp-down rate (Peak to 217°C)	Less than 6°C/second
Time from 25°C to Peak	No greater than 480 seconds

CATALOGUE NUMBERS

The resistors have a catalogue number starting with.

MF06	F	xxxx	B	T	L
Size code	Type code	Resistance code	Tolerance	Packaging code	Termination code
MF12: 1206	F: TCR 15 ppm	3 significant digits followed by no. of zeros	F : ±1%	T: 7" Taped & Reeled	L = Sn base (lead free)
MF08: 0805	W: TCR 10 ppm		D : ±0.5%	M: 7" Taped & Reeled.	
MF06: 0603		102Ω =1020	C : ±0.25%	Size: 0402 ,5Kpcs /RL	
MF04: 0402		37.4KΩ =3742	B : ±0.1%	Z : 7" Taped & Reeled	
		220Ω =2200	A : ±0.05%	3kpcs/RL	
				V : 7" Reel & Taped	
				1Kpcs	

1. Reeled tape packaging: 8mm width paper taping.

5,000pcs/Reel for MF06F&W; MF08F&W, MF12F&W

5,000pcs and 10,000pcs /Reel for MF04F&W



TEST AND REQUIREMENTS

TEST	PROCEDURE	REQUIREMENT
		Resistor
Electrical Characteristics IEC 60115-1 4.8	- DC resistance values measurement - Temperature Coefficient of Resistance (T.C.R) Natural resistance change per change in degree centigrade. $\frac{R_2 - R_1}{R_1(t_2 - t_1)} \times 10^6 \text{ (ppm/}^\circ\text{C)}$ $t_1 : 20^\circ\text{C}+5^\circ\text{C}-1^\circ\text{C}$ R_1 : Resistance at reference temperature ($20^\circ\text{C}+5^\circ\text{C}-1^\circ\text{C}$) R_2 : Resistance at test temperature (-55°C or $+125^\circ\text{C}$)	Within the specified tolerance
Short time overload (S.T.O.L) IEC 60115-1 4.13	Permanent resistance change after a 5second application of a voltage 2.5 times RCWV or the maximum overload voltage specified in the above list, whichever is less.	$\Delta R/R$ max. $\pm(0.1\%+0.02\Omega)$
Resistance to soldering heat(R.S.H) AEC-Q200-15	Un-mounted chips completely immersed for 10 ± 1 second in a SAC solder bath at $260^\circ\text{C}\pm 5^\circ\text{C}$	no visible damage $\Delta R/R$ max. $\pm(0.1\%+0.02\Omega)$
Solderability IEC 60068-2-58	Un-mounted chips completely immersed for 2 ± 0.5 second in a SAC solder bath at $235^\circ\text{C}\pm 5^\circ\text{C}$	good tinning (>95% covered) no visible damage
Temperature cycling JESD22 method JA-104	1,000 cycles, $-55^\circ\text{C} \sim +125^\circ\text{C}$, dwell time 5~10min	$\Delta R/R$ max. $\pm(0.1\%+0.02\Omega)$
	1,000 cycles, $-55^\circ\text{C} \sim +155^\circ\text{C}$, dwell time 5~10min	$\Delta R/R$ max. $\pm(0.2\%+0.02\Omega)$
Bias Humidity AEC-Q200-7	1,000 +48/-0 hours, loaded with 10% rated power in humidity chamber controller at $+85^\circ\text{C}/ 85\%\text{RH}$	$\Delta R/R$ max. $\pm(0.1\%+0.02\Omega)$
Load Life IEC 60115-1 4.25	1,000 +48/-0 hours, loaded with RCWV or V_{max} in chamber controller $85 \pm 2^\circ\text{C}$, 1.5 hours on and 0.5 hours off	$\Delta R/R$ max. $\pm(0.1\%+0.02\Omega)$
Operational Life AEC-Q200-8 MIL-STD-202 -108	1,000 hours at $125\pm 2^\circ\text{C}$, loaded with rated power continuously	$\Delta R/R$ max. $\pm(0.1\%+0.02\Omega)$
High Temperature Exposure AEC-Q200-3	1,000 hours 125°C , un-powered	$\Delta R/R$ max. $\pm(0.1\%+0.02\Omega)$
	1,000 hours 155°C , un-powered	$\Delta R/R$ max. $\pm(0.15\%+0.02\Omega)$
Moisture Resistance AEC-Q200-6 MIL-STD-202 Method 106	$65\pm 2^\circ\text{C}$, 80~100% RH, 10 cycles, 24 hours/ cycle	$\Delta R/R$ max. $\pm(0.1\%+0.02\Omega)$
Mechanical Shock MIL-STD-202 Method 213	1/2 Sine Pulse / 1500g Peak / Velocity 15.4ft/sec	$\Delta R/R$ max. $\pm(0.1\%+0.02\Omega)$

TEST	PROCEDURE	REQUIREMENT
		Resistor
Vibration MIL-STD-202 Method 204	5 g's for 20 min , 12 cycles each of 3 orientations	$\Delta R/R$ max. $\pm(0.1\%+0.02\Omega)$
Terminal strength AEC-Q200-6	1 kg for 60 s	No broken
Board flex AEC-Q200-005	Bending 2mm for 60 sec	$\Delta R/R$ max. $\pm(0.1\%+0.02\Omega)$
Flower of sulfur ASTM-B809-95	105 \pm 2 $^{\circ}$ C , duration 1,000hours.	0402 $\Delta R/R$ max. $\pm(0.2\%+0.02\Omega)$ others $\Delta R/R$ max. $\pm(0.1\%+0.02\Omega)$



PACKAGING

Paper Tape specifications (unit :mm)

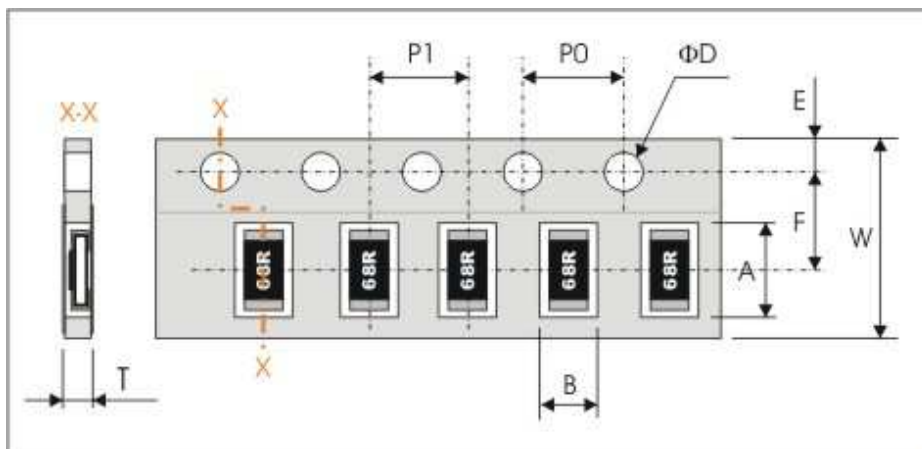

Series No.	A	B	W	F	E
MF12	3.60±0.20	2.00±0.20	8.00±0.30	3.50±0.20	1.75±0.10
MF08	2.40±0.20	1.65±0.20	8.00±0.30	3.50±0.20	1.75±0.10
MF06	1.90±0.20	1.10±0.20	8.00±0.30	3.50±0.20	1.75±0.10
MF04	1.20±0.10	0.7±0.10	8.00±0.30	3.50±0.05	1.75±0.10

Series No.	P1	P0	ΦD	T
MF12	4.00±0.10	4.00±0.10	Φ1.50 ^{+0.1} _{-0.0}	Max. 1.0
MF08	4.00±0.10	4.00±0.10	Φ1.50 ^{+0.1} _{-0.0}	Max. 1.0
MF06	4.00±0.10	4.00±0.10	Φ1.50 ^{+0.1} _{-0.0}	0.65±0.05
MF04	2.00±0.10	4.00±0.10	Φ1.50 ^{+0.1} _{-0.0}	0.40±0.05

Reel dimensions

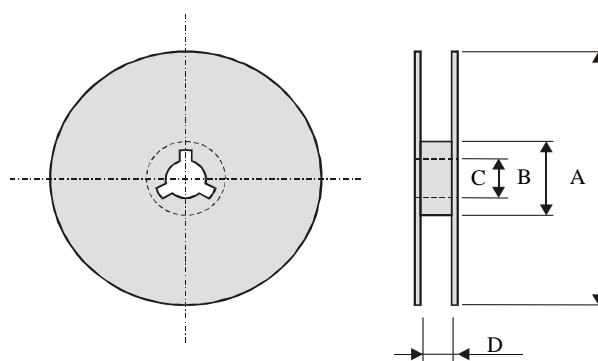

Symbol	A	B	C	D
(unit : mm)	Φ178.0±2.0	Φ60.0±1.0	13.0±0.2	9.0±0.5

Taping quantity

- Chip resistors 5,000 pcs per reel (MF06F&W, MF08F&W, MF12F&W)
- Chip resistors 5,000pcs and 10,000 pcs per reel (MF04F&W)

PULSE LOAD PERFORMANCE:

Single Pulse :

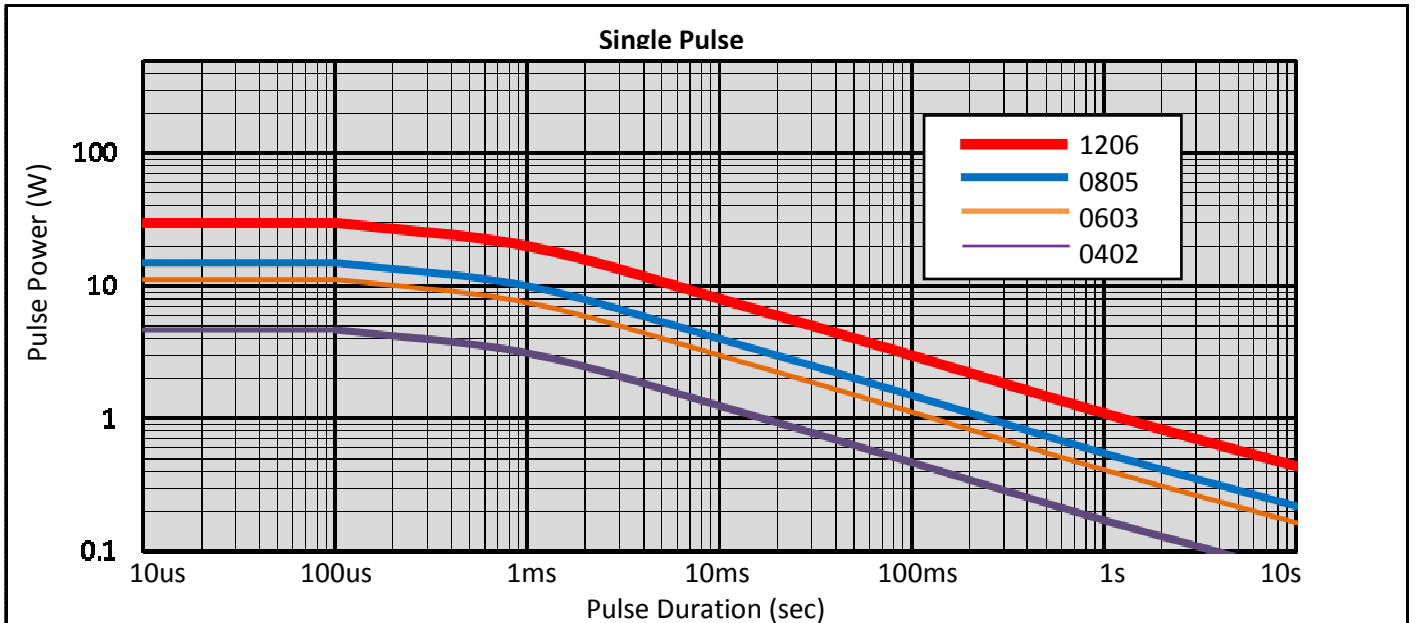

Single Pulse for $R \geq 10 \Omega$

50 rectangular pulse amplitudes are applied to the component at intervals of 60seconds, permissible the resistance to be varied by $\pm (0.5\% R + 0.01\Omega)$.

Continuous Pulse :

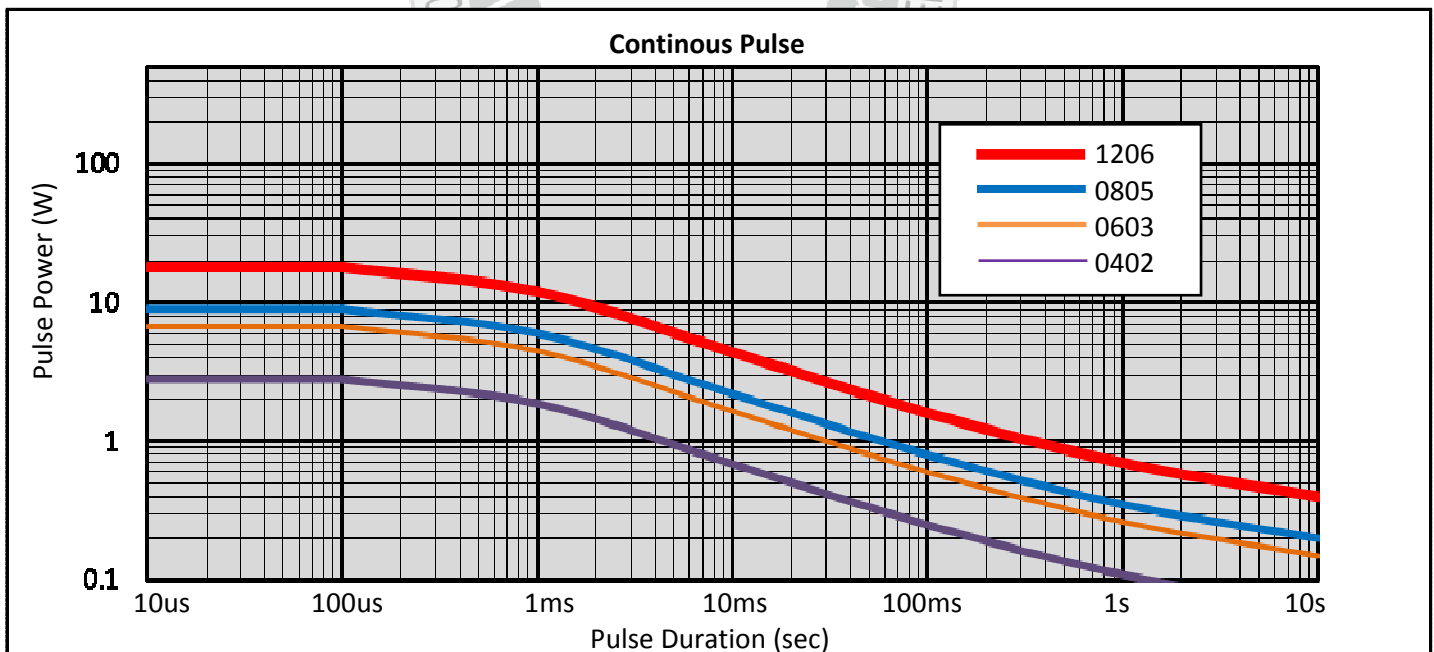

Continuous Pulse for $R \geq 10 \Omega$

Continuous load is a pulse period generated by the repetitive rectangular pulse amplitude, the applied power dissipation is at a rated power of 70 °C.

Permissible the resistance to be varied by $\pm (0.5\% R + 0.01\Omega)$.

Pulse Voltage :

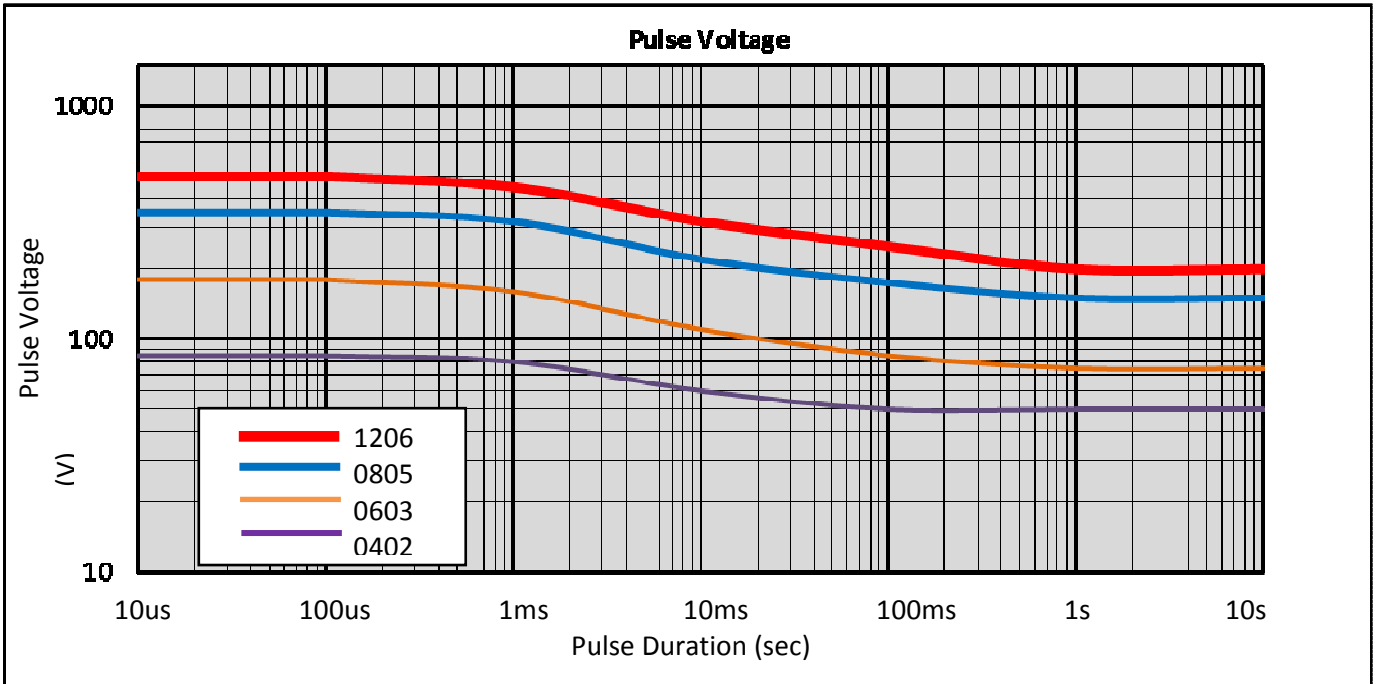

**Pulse Surge Overload :
1.2 / 50us Pulse**

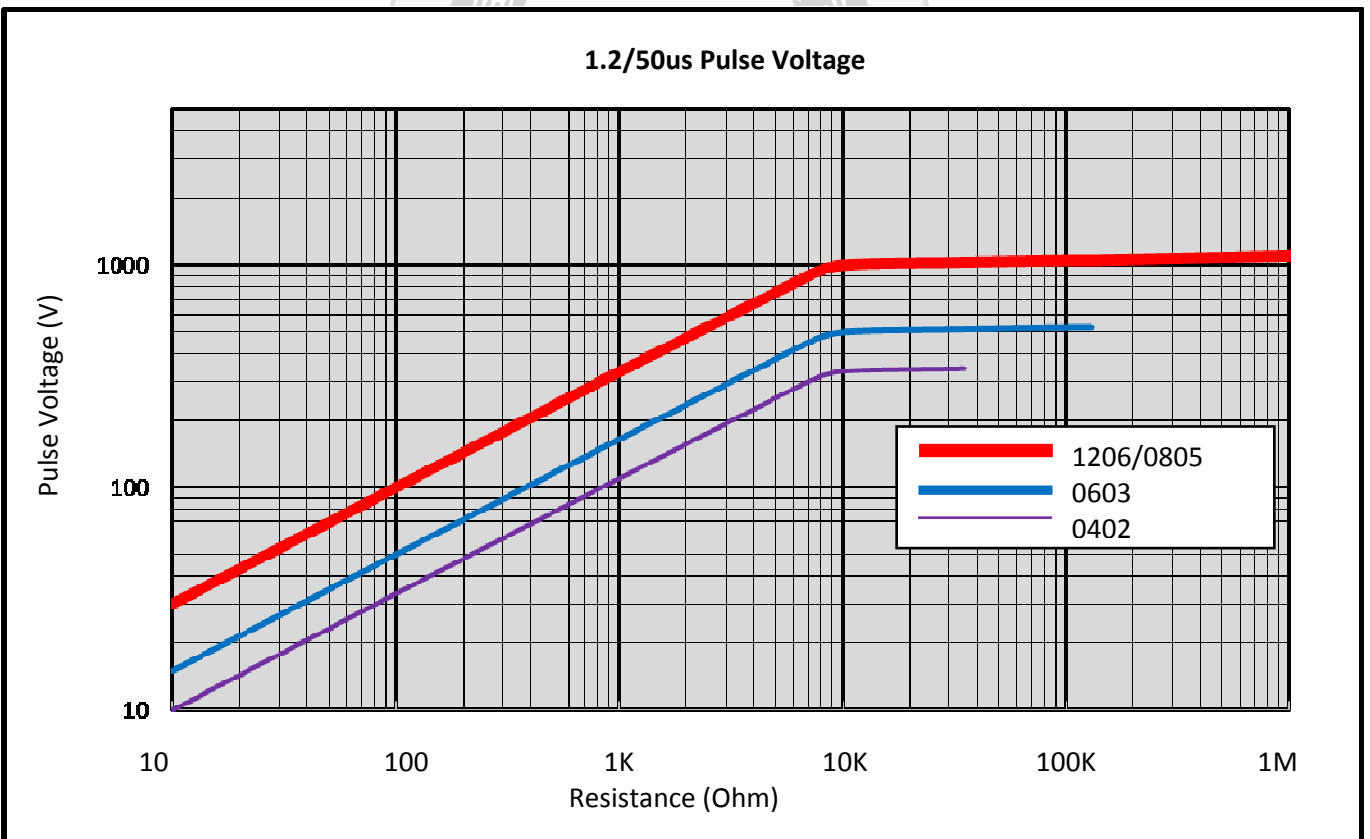

According to IEC 60115-1 4.27 1.2 / 50us use 5 pulses at 12sec intervals pulse shapes test resistor, permissible the resistance to be varied by $\pm (0.5\% R + 0.01\Omega)$.

10 / 700us Pulse

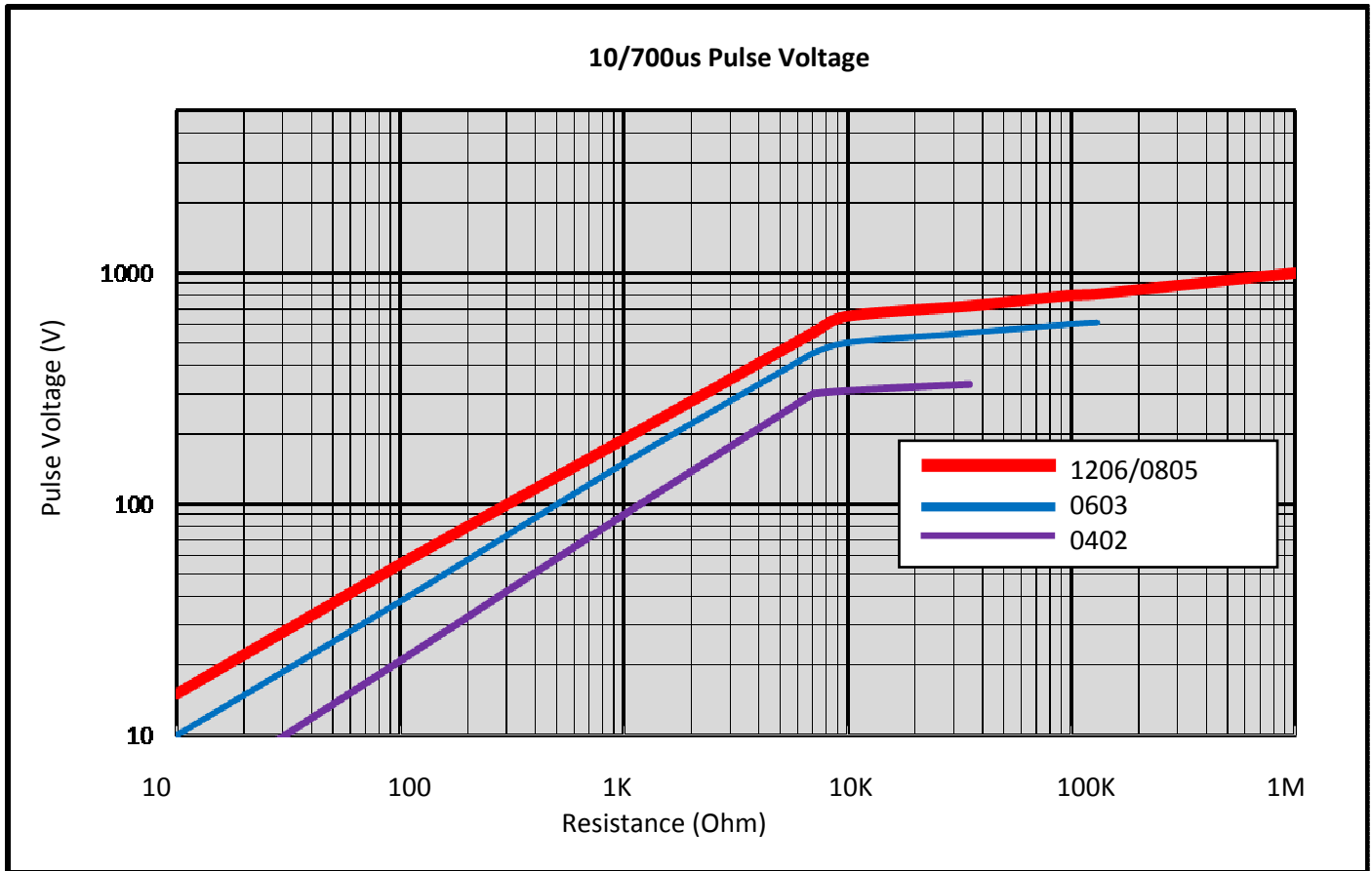

According to IEC 60115-1 4.27 10 / 700us use 10 pulses at 60sec intervals pulse shapes test resistor, permissible the resistance to be varied by $\pm (0.5\% R + 0.01\Omega)$.

