

Preliminary

DESCRIPTION

The MGF0918A GaAs FET with an N-channel schottky Gate, is designed for use UHF band amplifiers.

FEATURES

- High output power
Po=27dBm(TYP.) @f=1.9GHz,Pin=8dBm
- High power gain
Gp=20dB(TYP.) @f=1.9GHz
- High power added efficiency
ηadd=45%(TYP.) @f=1.9GHz,Pin=8dBm
- Hermetic Package

APPLICATION

- For UHF Band power amplifiers

QUALITY

- GG

RECOMMENDED BIAS CONDITIONS

- Vds=10V • Ids=150mA • Rg=1kΩ

Delivery Tape & Reel

Absolute maximum ratings (Ta=25°C)

Symbol	Parameter	Ratings	Unit
VGSO	Gate to source breakdown voltage	-15	V
VGDO	Gate to drain breakdown voltage	-15	V
ID	Drain current	400	mA
IGR	Reverse gate current	-1.2	mA
IGF	Forward gate current	5.0	mA
PT	Total power dissipation	3	W
Tch	Channel temperature	175	°C
Tstg	Storage temperature	-65 to +175	°C

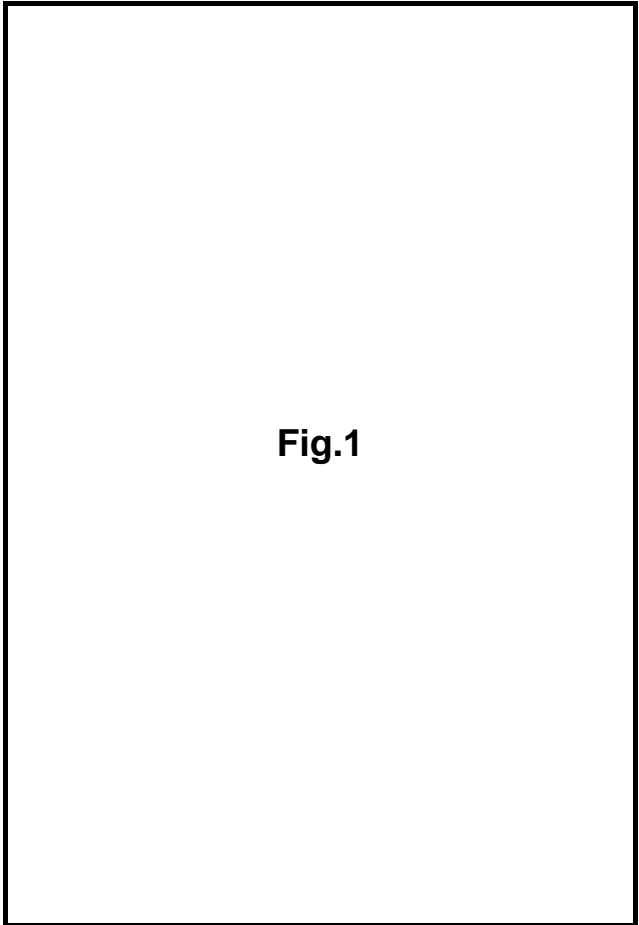

Fig.1

Electrical characteristics (Ta=25°C)

Symbol	Parameter	Test conditions	Limits			Unit
			Min.	Typ.	Max.	
IDSS	Saturated drain current	VDS=3V, VGS=0V	-	300	400	mA
VGS(off)	Gate to source cut-off voltage	VDS=3V, ID=1.0mA	-1.0	-	-5.0	V
gm	Transconductance	VDS=3V, ID=150mA	-	130	-	mS
Po	Output power	VDS=10V, ID=150mA, f=1.9GHz	25	27	-	dBm
ηadd	Power added Efficiency	Pin=8dBm	-	45	-	%
GLP	Linear Power Gain	VDS=10V, ID=150mA, f=1.9GHz	-	20	-	dB
NF	Noise figure		-	1.0	-	dB
Rth(ch-c)	Thermal Resistance *1	ΔVf Method	-	35	50	°C/W

*1: Channel to case / Above parameters, ratings, limits are subject to change.

MGF0918A TYPICAL CHARACTERISTICS

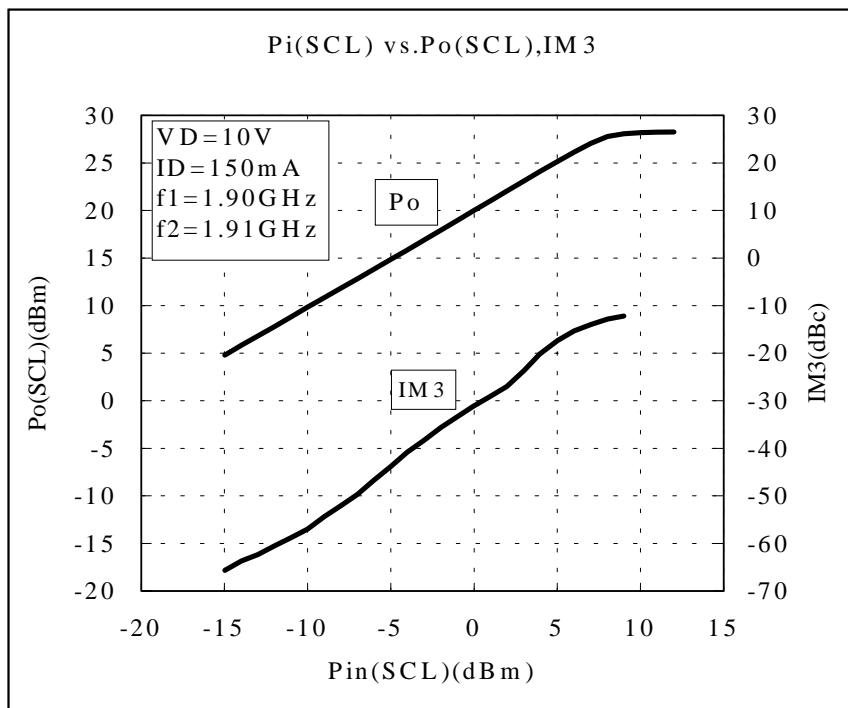
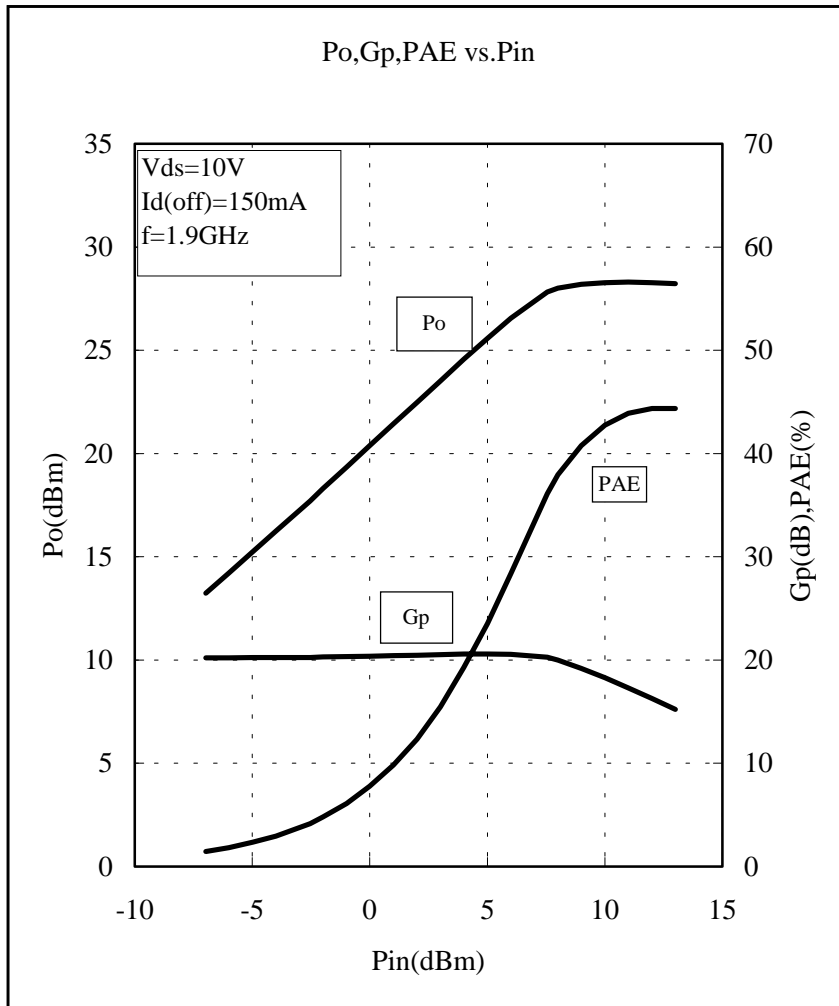

MGF0918A S PARAMETERS (Ta=25°C, VD=10V, ID=150mA, Reference Plane see Fig.1)

freq. (GHz)	S11		S21		S12		S22		K	MSG/MAG (dB)
	Mag	Ang(deg)	Mag	Ang(deg)	Mag	Ang(deg)	Mag	Ang(deg)		
0.4	0.96	-29.56	6.13	164.06	0.02	110.56	0.24	-44.00	0.11	24.89
0.6	0.95	-45.03	5.57	147.46	0.02	94.16	0.31	-56.07	0.14	24.29
0.8	0.94	-60.22	5.01	131.01	0.02	77.91	0.37	-67.82	0.19	23.66
1.0	0.93	-72.06	4.57	118.17	0.02	65.17	0.42	-77.03	0.23	23.11
1.2	0.93	-81.77	4.21	107.50	0.02	54.60	0.46	-84.71	0.26	22.60
1.4	0.92	-90.08	3.91	98.41	0.02	45.71	0.49	-91.25	0.28	22.13
1.6	0.92	-97.23	3.65	90.37	0.02	37.87	0.52	-96.98	0.32	21.87
1.8	0.92	-103.61	3.42	83.37	0.02	30.87	0.55	-102.08	0.34	21.45
2.0	0.91	-109.26	3.22	77.02	0.02	24.52	0.57	-106.67	0.37	21.21
2.2	0.91	-114.47	3.04	71.20	0.03	18.80	0.59	-110.93	0.39	20.82
2.4	0.91	-119.16	2.87	65.90	0.03	13.60	0.61	-114.80	0.42	20.60
2.6	0.90	-123.61	2.72	60.94	0.03	8.74	0.63	-118.34	0.43	20.23
2.8	0.90	-127.67	2.59	56.39	0.03	4.19	0.65	-121.78	0.46	20.03
3.0	0.90	-131.51	2.46	52.06	0.03	-0.04	0.66	-124.92	0.50	19.83
3.2	0.90	-135.04	2.35	48.04	0.03	-4.06	0.68	-127.94	0.50	19.48
3.4	0.90	-138.46	2.24	44.14	0.03	-7.86	0.69	-130.76	0.53	19.29
3.6	0.90	-141.69	2.14	40.54	0.03	-11.46	0.70	-133.48	0.57	19.10
3.8	0.89	-144.72	2.05	37.05	0.03	-14.85	0.71	-136.01	0.60	18.92
4.0	0.89	-147.64	1.96	33.78	0.03	-18.12	0.72	-138.52	0.63	18.73
4.2	0.89	-150.46	1.88	30.61	0.03	-21.29	0.73	-140.91	0.63	18.41
4.4	0.89	-153.19	1.80	27.54	0.03	-24.26	0.74	-143.13	0.66	18.22
4.6	0.89	-155.82	1.73	24.67	0.03	-27.23	0.75	-145.33	0.69	18.04
4.8	0.89	-158.36	1.66	21.81	0.03	-29.99	0.76	-147.53	0.73	17.86
5.0	0.89	-160.81	1.59	19.05	0.03	-32.65	0.77	-149.54	0.75	17.68
5.2	0.88	-163.16	1.53	16.39	0.03	-35.31	0.77	-151.54	0.75	17.36
5.4	0.88	-165.43	1.47	13.82	0.03	-37.88	0.78	-153.54	0.78	17.18
5.6	0.88	-167.70	1.41	11.37	0.03	-40.33	0.79	-155.44	0.81	17.00
5.8	0.88	-169.88	1.35	8.89	0.03	-42.71	0.79	-157.26	0.85	16.81
6.0	0.88	-172.07	1.30	6.53	0.03	-45.07	0.80	-159.07	0.88	16.63
6.2	0.88	-174.18	1.25	4.25	0.03	-47.35	0.81	-160.79	0.91	16.44
6.4	0.87	-176.22	1.20	1.98	0.03	-49.62	0.81	-162.58	0.90	16.11
6.6	0.87	-178.26	1.15	-0.30	0.03	-51.90	0.82	-164.38	0.91	15.78
6.8	0.87	179.68	1.10	-2.57	0.03	-54.17	0.82	-166.17	0.91	15.45
7.0	0.87	177.61	1.06	-4.85	0.03	-56.45	0.83	-167.97	0.91	15.11

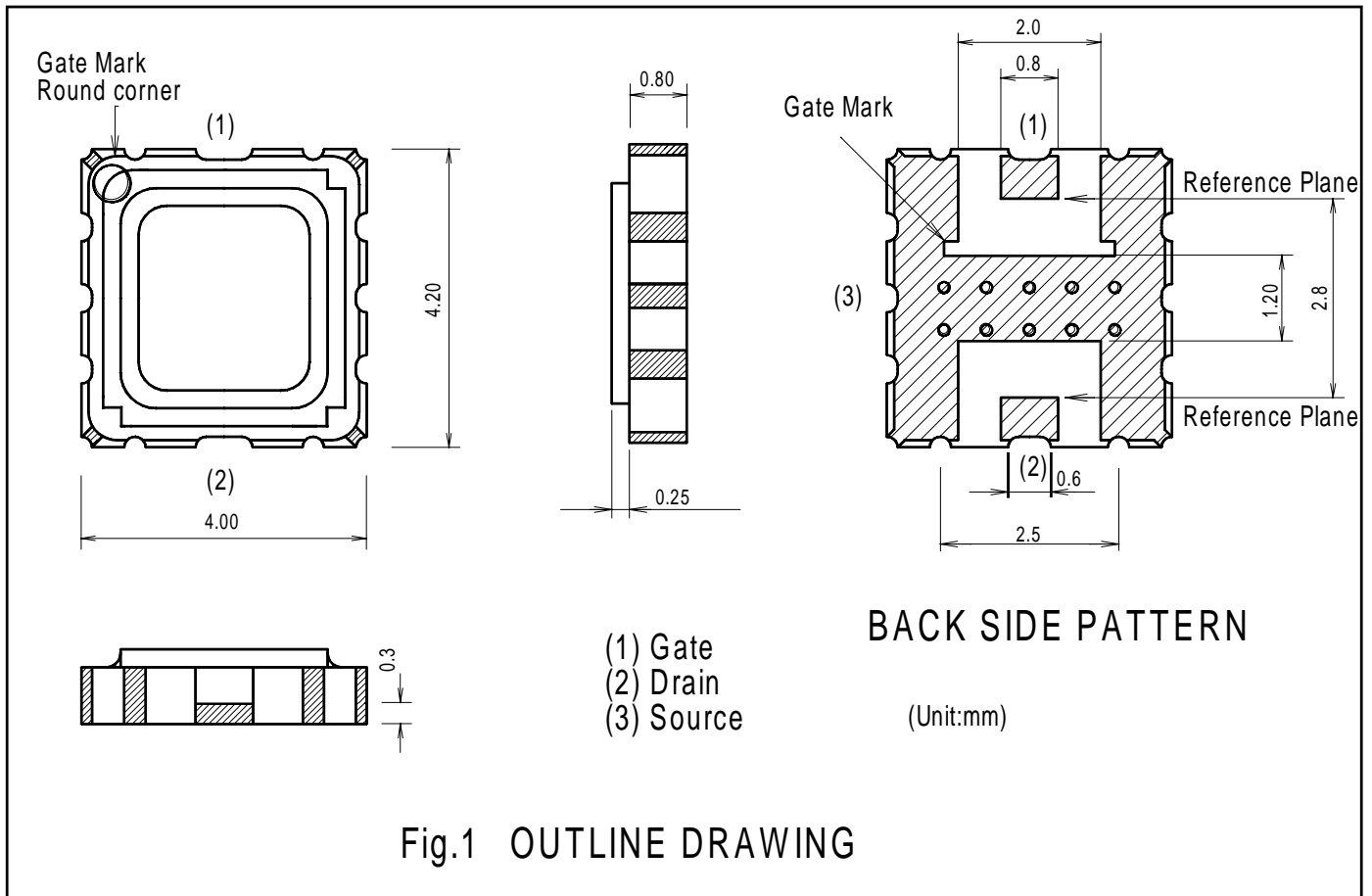

Fig.1 OUTLINE DRAWING