

Features

- Dual SLIC
- Ringing generation
- On-hook transmission
- Transformerless 2-4 wire conversion
- Constant current feed
- Battery Feed to the line
- Tip Ring reversal capability
- Over current protection
- Off-Hook detection
- Logic interface for $\overline{\text{SHK}}$, RC, LR, ESE, LCS
- Metering injection
- Wide V_{Bat} operating range
- Minimum installation space
- ESE ramped output

Applications

- Pair Gain
- CT2
- Cordless local loops

ISSUE 3

April 1995

Ordering Information

MH88622 -1, -2, -3,-5 40 Pin SIL Package

0°C to 70°C

Description

The Mitel MH88622 is a Dual Subscriber Interface Circuit which provides a complete interface between the telephone lines a dual codec, requiring a dual rail supply, battery and dc supply for ringing generation. The functions provided by the MH88622 includes 2-4 Wire conversion, constant current line feed, signalling and control. The SLIC manufactured using thick film hybrid technology which offers high voltage capability, reliability and high density resulting in a significant area saving on the printed circuit board. A complete C.O. type solution can be implemented with minimal external components. Different variants are provided to meet different country line impedance, they are:

-1	$220\Omega + (820\Omega // 115\text{nF})$
-2	600Ω
-3	$370\Omega + (620\Omega // 310\text{nF})$
-5	$200\Omega + (680\Omega // 100\text{nF})$

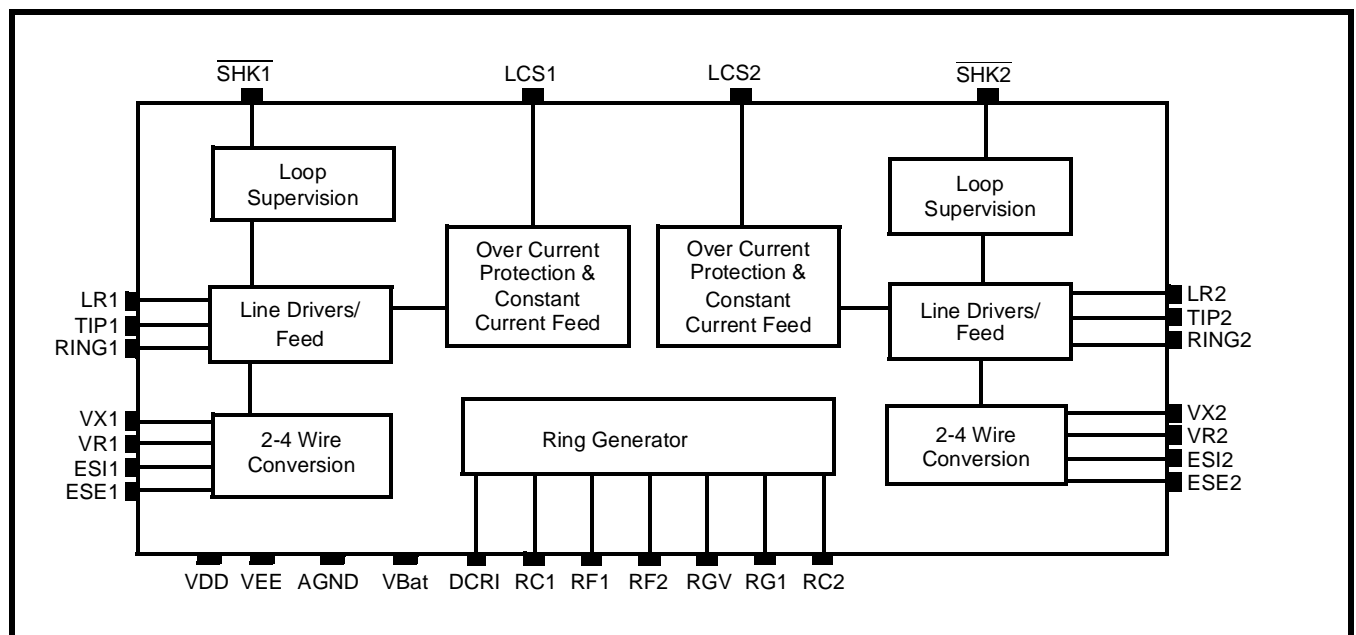

Figure 1 - Functional Block Diagram

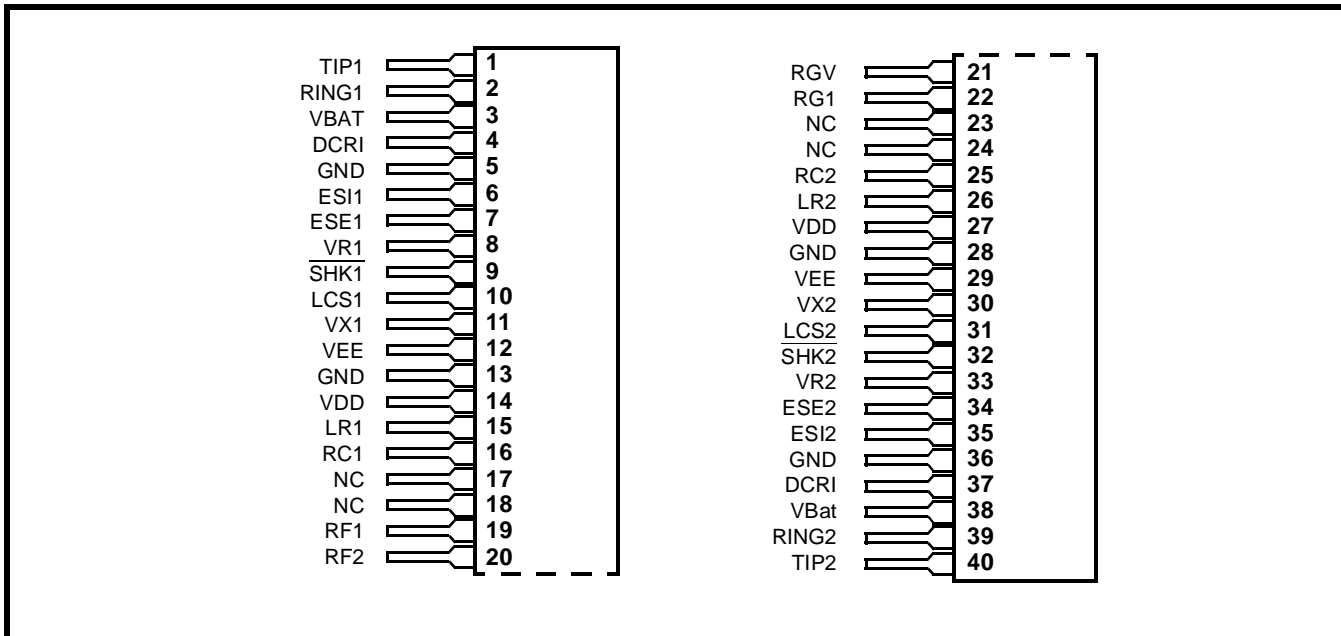

Figure 2 - Pin Connections

Pin Description

Pin #	Name	Description
1	TIP1	Tip Lead. Connects to the “TIP” lead of subscriber line 1.
2	RING1	Ring Lead. Connects to the “RING” lead of subscriber line 1.
3	V _{BAT}	Battery Voltage. Typically -48V dc is applied to this pin. This should be connected to pin 38 of the hybrid on the PCB.
4	DCRI	DC Ringing Voltage Input. A continuous 120V dc is applied to this input to achieve 90Vrms ringing. This should be connected to pin 37 of the hybrid.
5	GND	Ground. This pin should be tied to pins 13, 28 & 36 on the PCB.
6	ESI1	External Signal Input (Input). A continuous signal should be applied to this pin which will be switched to “Tip” and “Ring” of subscriber 1.
7	ESE1	External Signal Enable (Input). The external signal to the subscriber 1 is controlled by a logic level applied to this pin.
8	VR1	Receive (Input). 4-Wire GND referenced audio input for subscriber 1.
9	SHK1	Off Hook Indication (Output). A logic low output indicates when subscriber 1 equipment has gone off hook.
10	LCS1	Loop Current Set 1. Logic 1 gives I _{Loop} = 40mA, Logic 0 gives I _{Loop} = 25mA
11	VX1	Transmit (Output). 4-Wire, GND referenced audio output for subscriber 1.
12	VEE	Negative Supply Voltage. -5Vdc. Connects to pin 29 of the hybrid on the PCB.
13	GND	Ground. Return path for VDD, VEE, VBat & DCRI. This pin should be connected to pins 5, 28 & 36 of the hybrid on the PCB.
14	VDD	Positive Supply Voltage. +5Vdc. Connect to pin 27 of the hybrid on the PCB.
15	LR1	Line Reversal. A logic 1 applied to LR1 will reverse the “Tip” and “Ring” to subscriber 1. This pin has an internal pull down.
16	RC1	Ringing Control (Input). A logic level applied to this pin enables ringing to be applied across Tip and Ring of subscriber 1.

Pin Description (Continued)

Pin #	Name	Description
17	NC	No Connection. This pin should not be connected.
18	NC	No Connection. This pin should not be connected.
19	RF1	Ringing Frequency Node 1 (Input). A capacitor is connected between RF1 & RF2 and determines the frequency of the ringing generator.
20	RF2	Ringing Frequency Node 2 (Input). Two capacitors are connected between RF1 & RF2 and from RF2 to AGND. This determines the frequency of the ringing generator.
21	RGV	Ringing Gain Voltage. Connects to RG1 through a resistor to reduce the output ringing voltage. When left open circuit output ringing voltage is 90Vrms.
22	RG1	Ringing Gain Node 1. Connects to RGV through a resistor to reduce the output ringing voltage. When left open circuit output ringing voltage is 90Vrms.
23	NC	No Connection. This pin should not be connected.
24	NC	No Connection. This pin should not be connected.
25	RC2	Ringing Control (Input). A logic level applied to this pin enables ringing to be applied across Tip and Ring of subscriber 2.
26	LR2	Line Reversal. A logic 1 applied to LR2 will reverse the “Tip” and “Ring” to subscriber 2. This pin has an internal pull down.
27	VDD	Positive Supply Voltage. +5Vdc. This pin should be connected to pin 14 of the hybrid on the PCB.
28	GND	Ground. Return path for VDD, VEE, VBat & DCRI. This pin should be connected to pins 5, 13 & 36 of the hybrid on the pcb.
29	VEE	Negative Supply Voltage. -5Vdc. This pin should be connected to pin 12 of the hybrid on the PCB.
30	VX2	Transmit (Output). 4-Wire GND referenced audio input for subscriber 2.
31	LCS2	Loop Current Set 2. Logic 1 gives ILoop = 40mA, Logic 0 gives ILoop = 25mA.
32	SHK2	Off Hook Indication (Output). A logic high output indicates when subscriber 2 equipment has gone off hook.
33	VR2	Receive (Input). 4-Wire GND referenced audio input for subscriber 2.
34	ESE2	External Signal Enable (Input). The external signal to subscriber 2 is controlled by a logic level applied to this pin.
35	ESI2	External Signal Input. A continuous signal should be applied to this pin which will be switched to “Tip” and “Ring” of subscriber 2.
36	GND	Ground. This pin should be tied to pins 5, 13 & 28 on the PCB.
37	DCRI	DC Ringing Voltage Input. A continuous 120Vdc is applied to this input to achieve 90 Vrms ringing. This should be connected to pin 4 of the hybrid on the PCB.
38	VBAT	Battery Voltage. Typically -48V dc is applied to this pin. This should be connected to pin 3 of the hybrid on the PCB.
39	RING2	Ring Lead. Connects to the “Ring” lead of subscriber line 2.
40	TIP2	Tip Lead. Connects to the “Tip” lead of subscriber line 2.

Absolute Maximum Ratings *- All voltages are with respect to GNDA unless otherwise stated.

	Parameter	Symbol	Min	Max	Units
1	Supply Voltages - Referenced to V _{SS} (GND)	V _{EE}	+0.3	-15	V
		V _{DD}	-0.3	+15	V
		V _{DCRI}	-0.3	+180	V
		V _{Bat}	-60	0.3	V
2	Operating Temperature	T _{AMB}	-40	+85	°C
3	Storage Temperature	T _S	-55	+125	°C

* Exceeding these values may cause permanent damage. Functional operation under these conditions is not implied.

DC Electrical Characteristics

		Characteristics	Sym	Min [‡]	Typ*	Max [‡]	Units	Test Comments
1	S U P P L Y	Operating Loop Current	V _{EE}	-4.75	-5	-5.25	V	
			V _{DD}	4.75	5	5.25	V	
			V _{DCRI}	110	120	160	V	
			V _{Bat}	-60	-48	-20	V	
2	S U P P L Y	Operating Supply Current (per Channel)	I _{EE}		30		mA	On-hook On-Hook Ringing (REN=1) Idle
			I _{DD}		30		mA	
			I _{DCRI}		15		mA	
			I _{Bat}		5		mA	
3	I N P U T S	High Level Input Voltage LR, RC, ESE, LCS	V _{IH}	4.5			V	
4		Low Level Input Voltage LR, RC, ESE, LCS	V _{IL}			0.5	V	
5		High Level Input Current LR, RC, ESE, LCS	I _{IH}			700	μA	
6		Low Level Input Current LR, RC, ESE, LCS	I _{IL}			10	μA	
7	O U T P U T S	High Level Output Current SHK	I _{OH}			0.4	mA	
8		Low Level Output Current SHK	I _{OL}			4	mA	
9		High Level Output Voltage SHK	V _{OH}	4.75			V	
10		Low Level Output Voltage SHK	V _{OL}			0.4	V	
11		Constant Current Line Feed	I _{Loop}	23	25	27	mA	LCS = 0
12		Maximum Operating Loop	R _L			500 1500	Ω Ω	@ 25mA -24V @ 25mA -48V inclusive of telephone set
13		Power Consumption	P _C			300	mW	Excluding P _{BAT} & P _{DCRI}

* Typical figures are at 25°C with nominal ±5V supplies and are for design aid only.

‡ Max & Min figures guaranteed over 0°C to 70°C only

AC Electrical Characteristics*

	Characteristics	Sym	Min [‡]	Typ [†]	Max [‡]	Units	Test Comments
1	Gain VR to 2-Wire Gain relative to Gain @ 1kHz		-0.2	0 ±0.15	+0.2	dB	Input 1.0Vrms 1kHz @ VR, Zload = Z _{in} 300-3.4kHz
2	Gain 2-wire to VX Gain relative to Gain @ 1kHz		-6.2	-6 ±0.15	-5.8	dB	Input 3dBm 1kHz @ 2W Zsource = Z _{in} 300-3.4kHz
3	Off-Hook Detect Threshold			7.5		mA	
4	Transhybrid Loss	THL	22	30		dB	300-3.4kHz
5	Ringing Signal Voltage		40			Vrms	Min 65Vdc differential between DCRI & V _{BAT}
6	Ringing Frequency		17		68	Hz	See Table 1
7	Ringing Capability		4			REN	1750Ω impedance @ 20Hz min.
8	Power Supply Rejection Ratio $\frac{V_{Bat}}{V_{DD}/V_{EE}}$ V_{DCRI}	PSRR		30 30 30		dB	Ripple 0.1 VPP 1kHz
9	2-wire Return Loss		20	35		dB	Input 0.5 Vrms 1kHz across Tip & Ring Zload = Z _{in}
10	Longitudinal to Metallic Balance -1 Variant -2 Variant -3 Variant -5 Variant Metallic to Longitudinal Balance -2 Variant only		40 55 53 58 53 46 40 46 60 40			dB dB dB dB dB dB dB dB dB dB	Input 0.5Vrms 50-300Hz 300-1000Hz 1k-4kHz 200Hz to 1kHz 3kHz 300Hz to 3k4Hz 300Hz to 600Hz 600Hz to 3k4Hz 200Hz to 1kHz 1kHz to 4kHz
11	Input AC Impedance (2- wire) -1 variant (220Ω + 820Ω // 115nF) -2 variant (600Ω) -3 variant (370Ω + 620Ω // 310nF) -5 variant (200Ω + 680Ω // 100nF)	Z _{IN}		600 900 700 823		Ω	1kHz @ 2-wire
12	Input Impedance @ VR			230		kΩ	
13	Output Impedance @ VR			10		Ω	
14	Total Harmonic Distortion at VX at Tip & Ring	THD		0.2 0.2		% %	Input 4dBm @2-Wire Input 1V at VR
15	Common Mode Rejection Ratio 2-Wire to VX	CMRR	40	60		dB	Input 0,5V, 1kHz
16	Idle Channel Noise at VX at 2-wire	NC		15 15		dB _{rn} C	
17	On-Hook Transmission Signal Input Level Gain			6	2.0	Vrms dB	V _{Bat} = -48V T-R load = 10kΩ min.
18	External Signal Output Level		1.75	2.2		Vrms	V _{Bat} = -48V T-R load = 200Ω

AC Electrical Characteristics* (Continued)

	Characteristics	Sym	Min [‡]	Typ [†]	Max [‡]	Units	Test Comments
19	SHK Rise Time Fall Time	t_R t_F		1 1		ms ms	Dial Pulse Detection
20	Analogue Signal Overload Level @ Tip & Ring		4			dBm	@ 1kHz
21	Ring Trip Delay			100		ms	
22	Outband Noise	No			-70	dB	Refer to BS6305 section 4.1.4 & fig 3 for details of limits
23	Crosstalk	Channel 1 to 2 Channel 2 to 1			-80 -80	dB dB	@ 1kHz

* AC Electrical Characteristics are over Recommended Operating Conditions unless otherwise stated.

† Typical figures are at 25°C with nominal + 5V supplies and are for design aid only.

‡ Max and Min figures guaranteed over 0°C to 70°C only.

Notes: Impedance set to variant impedance

Test conditions uses a Z_{in} value as specified by variant number.

Test conditions use a transmit and receive gain set to 0dB default and a Z_{in} value of 600Ω unless otherwise stated.

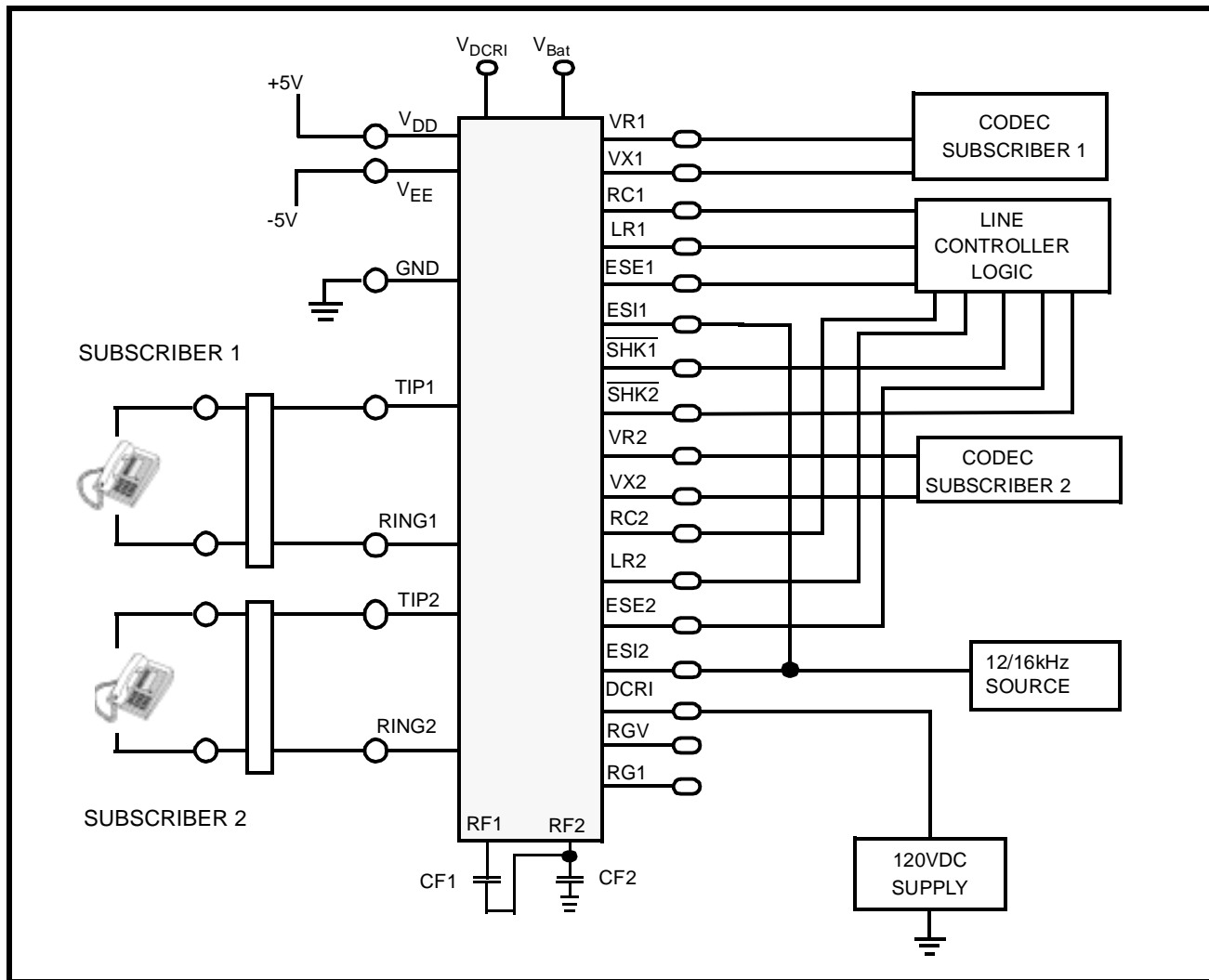

Figure 3 - Loop Start SLIC Configuration Application Circuit

Functional Description

The SLIC uses a Transformerless 2-4 Wire converter for each subscriber which can be connected to a CODEC to interface the 2-Wire subscriber loop to a time division multiplexed (TDM), pulse code modulated (PCM), digital link.

Powering of the subscriber line is provided through precision battery feed resistors on the hybrid. The thick film hybrid circuit contains control, signalling and status circuits which combine to provide a complete solution simplifying the manufacture of line cards.

Approvals

FCC part 68, CCITT, DOS CS-03, UL 1459, CAN/CSA-22.2 N0. 225-M90 and ANSI/EIA/TIA-464-A are system level safety standards and performance requirements. As a component of a system, the MH88622 is designed to comply with the applicable requirements of these specifications.

Battery Feed

The SLIC is designed for a nominal battery voltage of -48 Vdc and can provide the constant feed current for 1500Ω loop under this condition.

The interface circuit is designed to be operated up to a maximum of -60V dc battery feed voltage without damage, providing a minimum loop length capability of 2000Ω.

There is also a function on the SLIC that provides for Tip-Ring reversal.

Current Limit

Primary over current protection is inherent in the current limiting feature of the battery feed circuit.

Current limiting is provided for both Tip and Ring unbalanced conditions.

The maximum loop current limit is set internally on the interface and current limiting does not affect the longitudinal or the signal balance of the device. To set I_{Loop} to 40mA tie the LCS pin high (Logic 1), to set I_{Loop} to 25mA the LCS pin may be left open circuit or tied low (Logic 0).

Two Wire Port Termination Impedance

The Tip/Ring impedance (Z_{in}) is fixed for each variant.

Transmit and Receive Gain

The transmit and receive gain of the MH88622 is internally set.

Internal Ringing Generator

The MH88622 offers an on board ringing generator requiring only two external passive components and a DC voltage source to produce a sine wave of between 17Hz to 68Hz.

An internal signal is amplified by a user programmed amount and is applied to Tip and Ring. The programmable gain must be set using RGV and RG1 to ensure that distortion of the ringing signal is minimised.

With $V_{BAT} = -48Vdc$ and $V_{DCRI} = +120Vdc$ and the ringing voltage = 90Vrms RGV and RG1 should be left open circuit. By adding an external resistor between RGV and RG1 it is possible to reduce the ringing voltage applied by the driver section to Tip and Ring.

The DC voltage source should be continuously applied to the MH88622. The ringing voltage will only be applied when the RC pin of the relevant subscriber is activated.

Typ. Frequency (Hz)	CF1, CF2 (nF)
17	100
25	68
35	47
50	33

Table 1 - Ring Generator Capacitor Selection

12-16kHz Meter Pulse

The MH88622 provides control of an external signal path to the driver. A 12/16 KHz continuous signal should be applied to the ESI pin. Control of the ESE input allows the metering signal to be transmitted to the line with a ramped up and down amplitude to reduce noise on the line. Typical ramp time is 10mS.

Off-Hook and Dial Pulse Detection

The $\overline{\text{SHK}}$ pin goes low when the DC loop current exceeds a specified level. The threshold level is internally set by the bias voltage of the switch hook detect circuit.

Dial pulse can be detected by monitoring the interruption rate at the $\overline{\text{SHK}}$ pin. These dial pulses may need to be debounced by the systems software.

Ring Trip Detection

The interface permits detection of an Off-Hook condition during ringing. If the subscriber set goes Off-Hook when the ringing signal has been applied, the DC loop current flow will be detected within approx. 100msecs and the $\overline{\text{SHK}}$ output will go low. The ringing is automatically disabled by the internal hardware.

Longitudinal Balance

Precision laser trimming of resistors in the hybrids ensures good overall longitudinal balance.

The interface circuitry can operate in the presence of induced longitudinal currents of up to 40mA rms at 60Hz.

High Voltage Capability

Inherent in the thick film process is the ability of the thick film process dielectric strengths of greater than 1000 VAC or 1500 VDC. The thick film process allows easy integration of surface mount components such as the high voltage bi-polar power transistor line drivers. This allows for simpler, less elaborate and less expensive protection circuitry required to handle high voltage transients and fault conditions caused by lightning, induced voltages and power line crossing.

On Hook Transmission

The MH88622 provides for on-hook transmission which supports features such as Automatic Number identifications (ANI).

Loop Length

The MH88622 can accommodate loop length of up to 2000 Ω minimum (including the subscriber equipment).

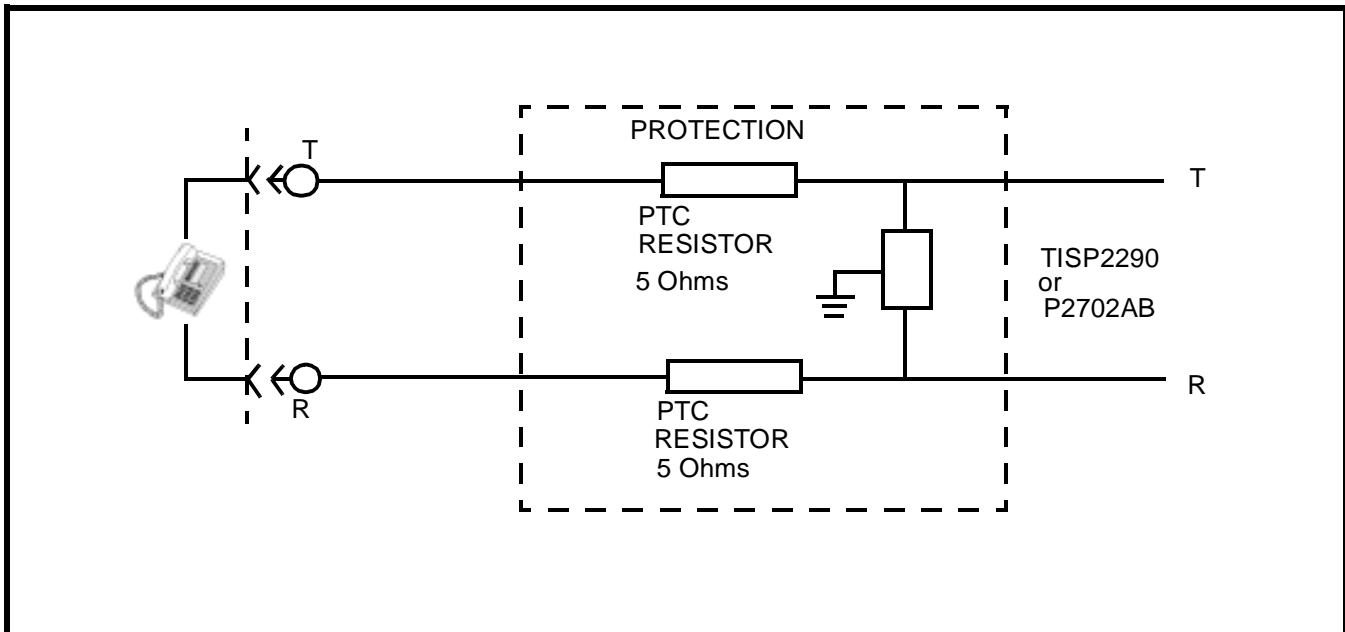

Figure 4 - Typical Protection Circuit

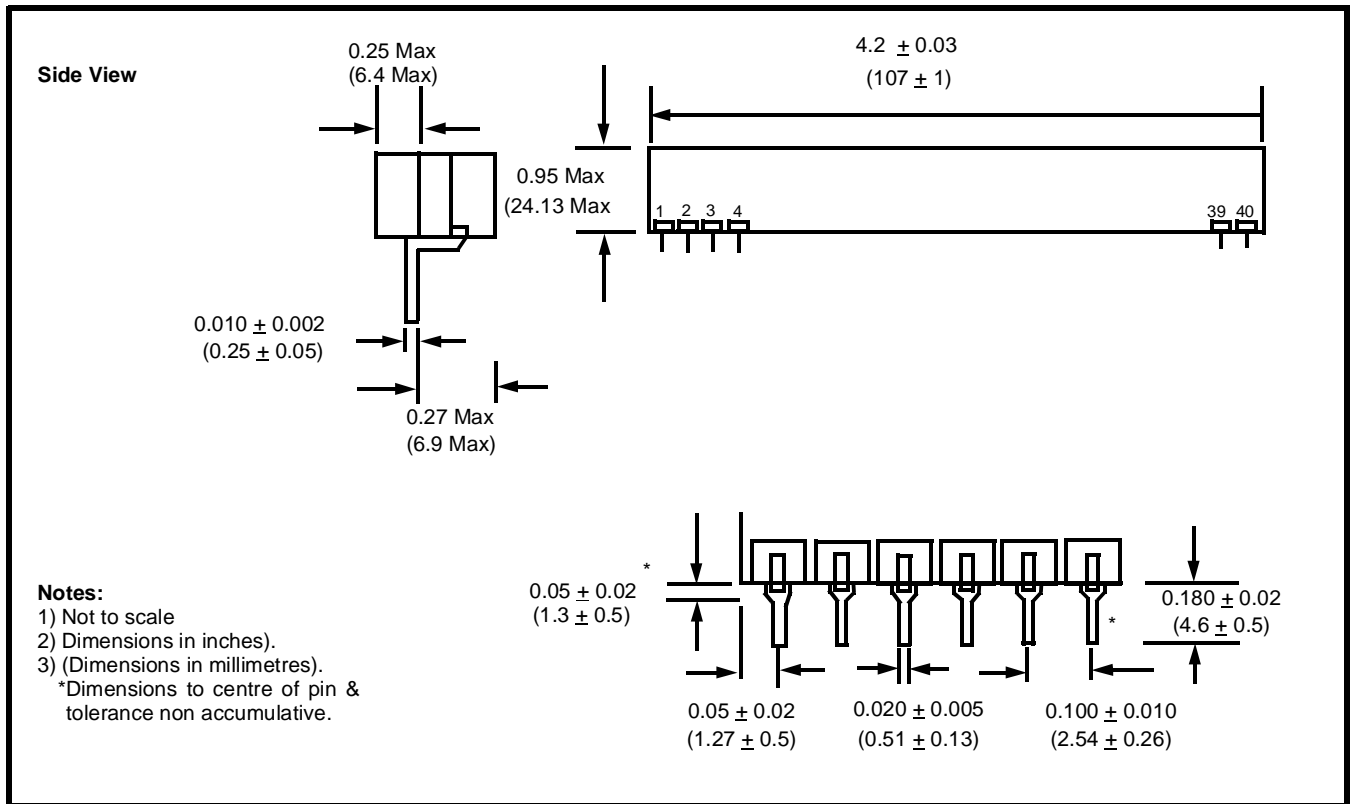

Figure 5 - Mechanical Data

Notes: