

MIP301

Silicon MOS IC

■ Features

- 100V high breakdown voltage MOS FET and CMOS control circuits are integrated into one chip
- 5V and 3 - 5W output with 24VDC input (Flyback method)

■ Applications

- IPD for DC/DC converter

■ Absolute Maximum Ratings (Ta = 25 ± 3°C)

Parameter	Symbol	Ratings	Unit
Drain voltage	V _D	90	V
Control voltage	V _C	8	V
Input voltage	V _{IN}	30	V
Output current	I _D	1.1	A
Control current	I _C	0.1	A
Channel temperature	T _{ch}	150	°C
Storage temperature	T _{stg}	-55 to +150	°C

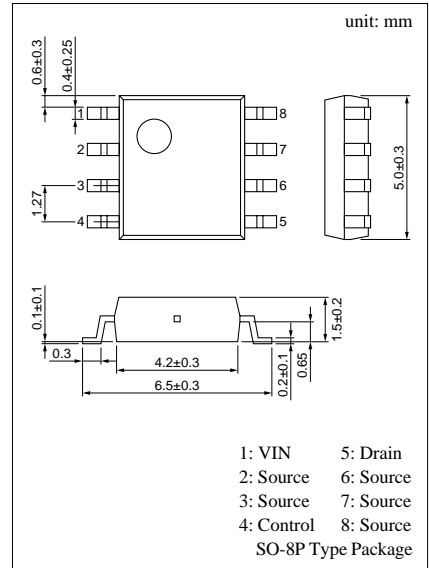

■ Block Diagram

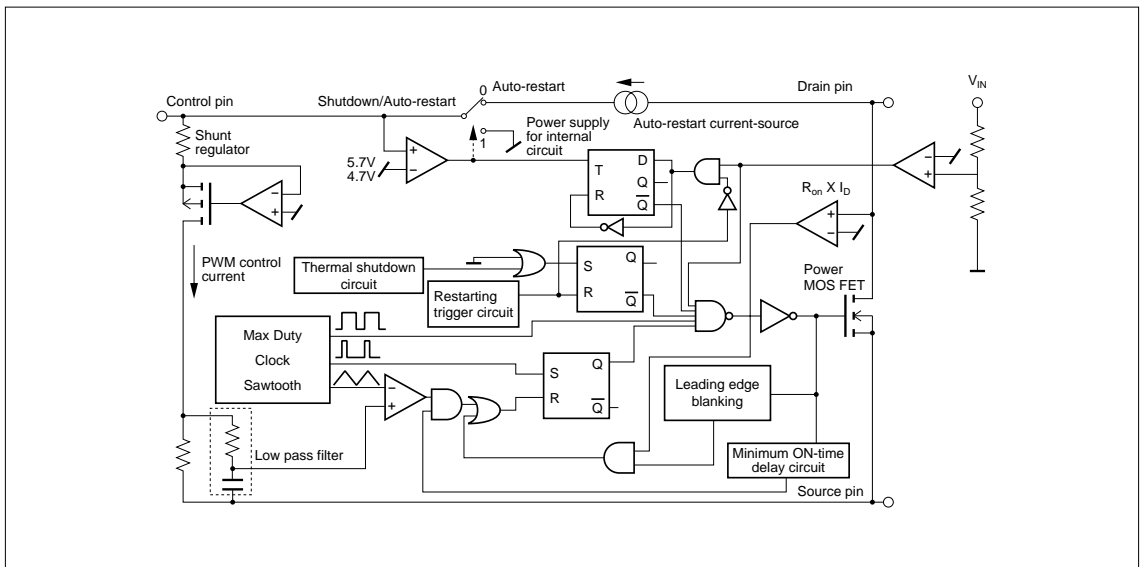

■ Electrical Characteristics ($T_C = 25 \pm 2^\circ\text{C}$)

	Parameter	Symbol	Conditions	min	typ	max	Unit
Control functions	Output frequency	f_{OSC}	$I_C = 2\text{mA}$	180	200	220	kHz
	Maximum duty cycle	MAXDC	$I_C = 2\text{mA}$	77	80	83	%
	Minimum duty cycle	MINDC	$I_C = 10\text{mA}$	0	3	5	%
	PWM gain	GPWM		-21	-16	-11	%/mA
	Circuit current	I_s		0.8	2.5	4	mA
	Dynamic impedance	ZC	$I_C = 3\text{mA}$	10	15	25	Ω
Auto-restart	Control pin charging current	I_C	$V_C = 0$	-2.4	-1.9	-1.2	mA
			$V_C = 5\text{V}$	-2	-1.5	-0.8	mA
	Auto-restart threshold voltage	$V_{C(\text{on})}$		5	5.7	6.3	V
	Lockout threshold voltage	$V_{C(\text{off})}$		4	4.7	5.3	V
	Auto-restart hysteresis voltage	ΔV_C		0.5	1	1.5	V
Circuit protection	Self-protection current limit	I_{LIMIT}		0.9	1	1.1	A
	Leading edge blanking delay	$t_{\text{on(BLK)}}$	$I_C = 3\text{mA}$		0.25		μs
	Current limit delay	$t_{\text{d(OCL)}}$	$I_C = 3\text{mA}$		0.1		μs
	Thermal shutdown temperature	T_{OTP}	$I_C = 3\text{mA}$	130	140	150	$^\circ\text{C}$
	Power-up reset threshold voltage	$V_{C \text{ reset}}$		2.3	3.3	4.2	V
Output	ON-state resistance	$R_{\text{DS(on)}}$	$I_D = 1\text{A}$		1.8	2.2	Ω
	OFF-state current	I_{DSS}	$V_{\text{DS}} = 82\text{V}$ Output MOS FET disabled		0.01	0.25	mA
	Breakdown voltage	V_{DSS}	$I_D = 0.25\text{mA}$ Output MOS FET disabled	92			V
	Rise time	t_r			0.1	0.2	μs
	Fall time	t_f			0.1	0.2	μs
Power supply voltage	Start threshold voltage	$V_{\text{IN(START)}}$		16		18.2	V
	Stop threshold voltage	$V_{\text{IN(STOP)}}$		10		12.2	V
	Input hysteresis voltage	ΔV_{IN}		5.5		7.5	V
	Shunt regulator voltage	V_C	$I_C = 3\text{mA}$	5.4	5.7	6.1	V
	Control supply/discharge current	I_{CD}	Output MOS FET disabled	0.5	0.8	1.1	mA