

**ML674001/Q4002/Q4003****32-bit ARM-Based General-Purpose Microcontroller****GENERAL DESCRIPTION**

The ML674001, ML67Q4002, and ML67Q4003 microcontrollers (MCUs) are the members of an extensive and growing family of 32-bit ARM<sup>®</sup>-based standard products for general-purpose applications that require 32-bit CPU performance and low cost afforded by MCU integrated features.

ML674001/67Q4002/67Q4003 provide built-in 32Kbyte SRAM, built-in 4Kbyte boot ROM, and a host of other useful peripherals such as auto-reload timers, watchdog timer (WDT), pulse-width modulators (PWM), A-to-D converter, expanded UARTs, synchronous serial port, I2C serial interface, GPIOs, DMA controller, external memory controller, and boundary scan capability. In addition, the ML67Q4002 and ML67Q4003 offer 256 Kbytes and 512 Kbytes of built-in Flash memory respectively. The ML674001, ML67Q4002 and ML67Q4003 are pin-to-pin compatible with each other for easy performance updates.

Oki's ML674K Family MCUs are capable of executing both the 32-bit ARM instruction set for high-performance applications as well as the 16-bit Thumb<sup>®</sup> instruction set for high code-density, power-efficient applications. With an ARM7TDMI<sup>®</sup> core operating at 33 MHz maximum frequency, ARM Thumb<sup>™</sup> capabilities, and robust feature sets, the ML674001 Series MCUs are suitable for an array of applications including high performance industrial controllers and instrumentation, telecom, PC peripherals, security/surveillance, test equipment, and a variety of consumer electronics devices.

**The ARM7TDMI<sup>®</sup> Advantage**

Oki's ML674K Family of low-cost ARM-based MCUs offers system designers a bridge from 8- and 16-bit proprietary MCU architectures to ARM's higher-performance, affordable, widely-accepted industry standard architecture and its industry-wide support infrastructure. The ARM industry infrastructure offers the system developers many advantages including software compatibility, many ready-to-use software applications, large choices among hardware and software development tools. These ARM-based advantages allow Oki's customers to better leverage engineering resources, lower development costs, minimize project risks, and reduce their product time to market. In addition, migration of a design with an Oki standard MCU to an Oki custom solution is easily facilitated with its award-winning uPLAT<sup>™</sup> product development architecture.

**FEATURES**

## •CPU

32-bit RISC CPU (ARM7TDMI)

32-bit instructions (ARM Instructions) and 16-bit instructions (Thumb Instructions) mixed

General purpose registers : 31 x 32 bits

Built-in Barrel shifter and multiplier (32 bit x 8 bit, Modified Booth's Algorithm)

Little endian

Built-in debug function

## •Internal memory

RAM 32KB (32-bit access)

FLASH (16-bit access)

ML674001 : ROM-less version

ML67Q4002 : 256Kbytes

ML67Q4003 : 512Kbytes



ARM, ARM7TDMI, Multi-ICE and AMBA are registered trademarks of ARM Ltd., UK.

μPLAT is Oki's trademark.

The contents of this data sheet are subject to change for modification without notice.

- External memory controller
  - ROM (FLASH): 16 Mbytes
  - SRAM: 16 Mbytes
  - DRAM: 64 Mbytes (SDRAM and EDO-DRAM support)
  - External IO devices: 16 Mbytes x 2 banks, 4 Chip select pins
    - Wait control input signal for each bank
    - Independent programmable wait settings for each bank
- Interrupt controller
  - 28 sources: 23 internals and 5 externals (IRQ: 4, FIQ: 1)
- DMA controller
  - 2 channels: Dual address mode, cycle steal and burst transfer mode
- Timer
  - 1 channel: 16-bit auto reload for operating system
  - 6 channels: 16-bit auto reload for application
  - 1 channel: 16 bit watchdog timer
- Serial interface
  - 1 channel: UART
  - 1 channel: UART with 16-byte FIFO
  - 1 channel: synchronous
  - 1 channel: I2C (single master)
- Parallel I/O Port
  - 4 ports x 8 bits (bitwise input/output settings)
  - 1 port x 10 bit (bitwise input/output settings)
- PWM
  - 2 channels x 16 bits
- Analog-to-Digital Converter
  - 4 channels x 10 bits
- Power down mechanism
  - Standby (all clock stop) and Halt (clock stop by each function block)
  - Clock gear (selectable 1/1, 1/2, 1/4, 1/8, 1/16 input clock frequency)
- JTAG interface
  - Connectable to JTAG ICE
- Power supply voltage
  - Core section: 2.25 V to 2.75 V
  - IO section: 3.0 V to 3.6 V
  - Analog section: 3.0 V to 3.6 V
- Operating frequency
  - 1-33 MHz
- Operating temperature (ambient temperature)
  - 40°C to +85°C
- Package
  - 144-pin plastic LQFP (LQFP144-P-2020-0.50)
  - 144-pin plastic LFBGA (P-LFBGA144-1111-0.80)

**BLOCK DIAGRAM**

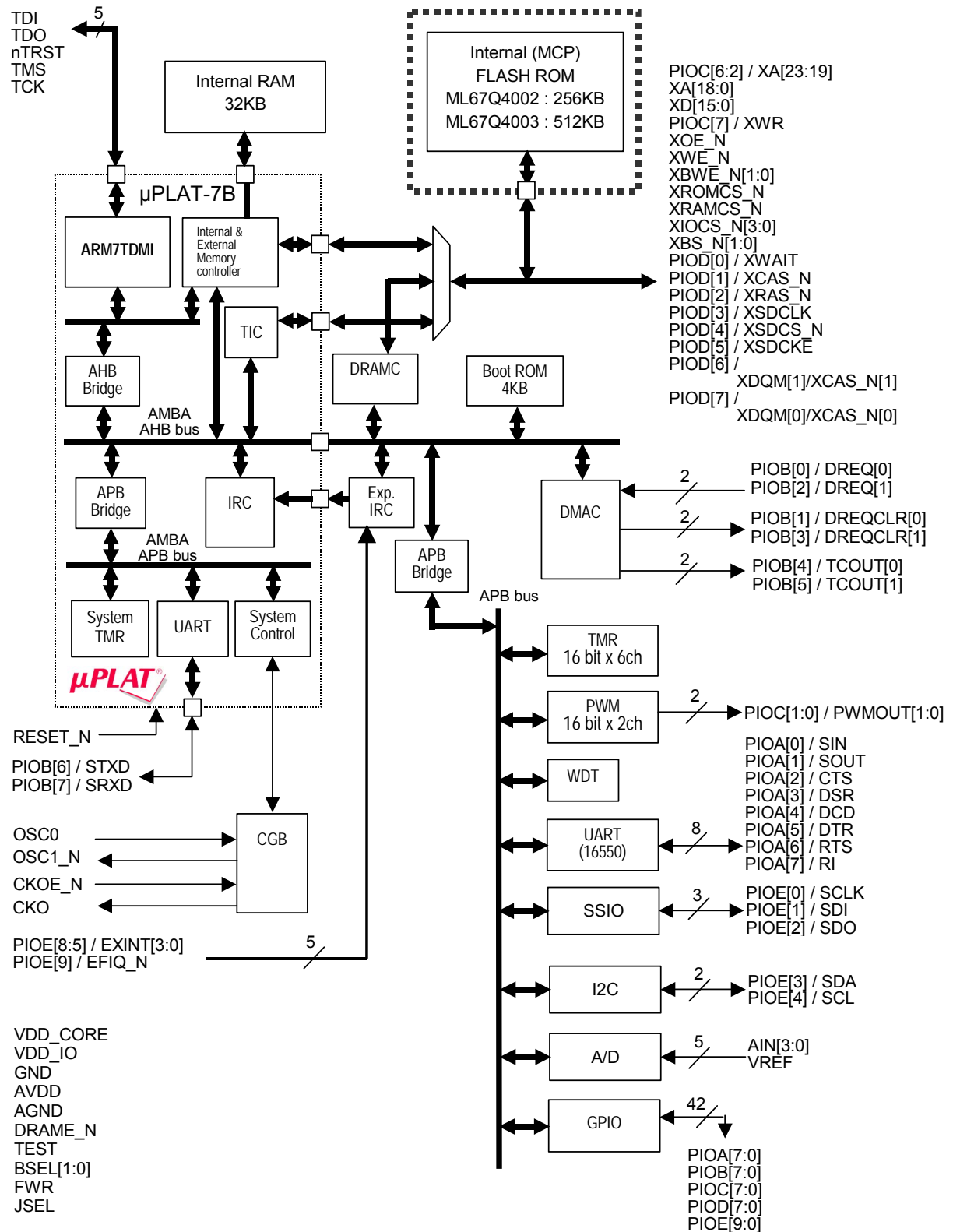

## PIN CONFIGURATION (TOP VIEW)

## 144-Pin Plastic LFBGA

	13	12	11	10	9	8	7	6	5	4	3	2	1
<b>N</b>	PIOD[6]/ XDQM[1] ]	XIOCS_ N[3]	XIOCS_ N[1]	XRAMC S_N	XBWE_ N[0]	XOE_N	PIOC[4]/ XA[21]	XA[16]	XA[14]	XA[11]	XA[9]	XA[7]	XA[6]
<b>M</b>	PIOD[7]/ XDQM[0] ]	XIOCS_ N[2]	XIOCS_ N[0]	XWE_N	PIOC[7]/ XWR	PIOC[6]/ XA[23]	PIOC[2]/ XA[19]	XA[17]	XA[15]	XA[13]	XA[10]	XA[4]	XA[5]
<b>L</b>	PIOB[1]/ DREQC LR[0]	PIOB[2]/ DREQ[1]	PIOB[0]/ DREQ[0]	XROMC S_N	XBWE_ N[1]	PIOC[5]/ XA[22]	PIOC[3]/ XA[20]	XA[18]	XA[12]	VDD_IO	XA[8]	XA[2]	GND
<b>K</b>	PIOB[3]/ DREQC LR[1]	PIOB[5]/ TCOUT[ 1]	VDD_IO	GND	VDD_IO	VDD_C ORE	VDD_IO	GND	GND	XA[3]	XA[0]	XD[13]	XA[1]
<b>J</b>	PIOC[0]/ PWMOU T[0]	GND	PIOB[4]/ TCOUT[ 0]	PIOC[1]/ PWMOU T[1]	<b>144pin LFBGA (TOP VIEW)</b>					VDD_IO	XD[15]	XD[11]	XD[14]
<b>H</b>	XBS_N[ 0]	XBS_N[ 1]	PIOD[0]/ XWAIT	VDD_C ORE						VDD_C ORE	XD[10]	NC	XD[12]
<b>G</b>	PIOD[2]/ XRAS_N	PIOD[1]/ XCAS_N	VDD_IO	GND						VDD_IO	XD[8]	NC	XD[9]
<b>F</b>	BSEL[1]	PIOD[5]/ XSDCK E	PIOD[3]/ XSDCLK	PIOD[4]/ XSDCS_ N						GND	XD[7]	XD[6]	XD[5]
<b>E</b>	PIOE[7]/ EXINT[2]	BSEL[0]	PIOE[8]/ EXINT[3]	PIOE[5]/ EXINT[0]						GND	XD[2]	NC	XD[4]
<b>D</b>	PIOE[3]/ SCLK	PIOE[6]/ EXINT[1]	PIOE[9]/ EFIQ_N	PIOE[2]/ SDO	OSC1_N	PIOA[1]/ SOUT	AIN[0]	NC	VDD_IO	GND	VDD_IO	XD[3]	XD[1]
<b>C</b>	TDI	PIOE[1]/ SDI	CKO	TMS	CKOE_ N	AVDD	AIN[1]	AIN[3]	VDD_C ORE	PIOA[5]/ DTR	FWR	XD[0]	RESET_ N
<b>B</b>	nTRST	TDO	TCK	GND	VDD_IO	PIOA[0]/ SIN	VREF	AGND	GND	PIOA[3]/ DSR	PIOA[7]/ RI	PIOE[4]/ SCL	PIOB[7]/ SRXD
<b>A</b>	NC	NC	JSEL	DRAME_ N	OSC0	TEST	AIN[2]	PIOA[2]/ CTS	PIOA[4]/ DCD	PIOA[6]/ RTS	PIOE[3]/ SDA	PIOB[6]/ STXD	NC
	13	12	11	10	9	8	7	6	5	4	3	2	1

Notes: NC pins are electrically unconnected in the package.  
NC pins can be connected to Vdd or GND.

144-Pin Plastic LQFP

		(Primary)	(Secondary)		
		108	109	72	XIOCS_N[3]
		107	110	71	XIOCS_N[2]
		106	111	70	XIOCS_N[1]
		105	112	69	GND
		104	113	68	XIOCS_N[0]
		103	114	67	XRAMCS_N
		102	115	66	XROMCS_N
		101	116	65	XBWE_N[1]
		100	117	64	XBWE_N[0]
		99	118	63	XWE_N
		98	119	62	VDD_IO
		97	120	61	XOE_N
		96	121	60	PIOC[7]
		95	122	59	PIOC[6]
		94	123	58	VDD_CORE
		93	124	57	PIOC[5]
		92	125	56	PIOC[4]
		91	126	55	PIOC[3]
		90	127	54	VDD_IO
		89	128	53	PIOC[2]
		88	129	52	XA[18]
		87	130	51	GND
		86	131	50	XA[17]
		85	132	49	XA[16]
		84	133	48	XA[15]
		83	134	47	GND
		82	135	46	XA[14]
		81	136	45	XA[13]
		80	137	44	XA[12]
		79	138	43	XA[11]
		78	139	42	XA[10]
		77	140	41	VDD_IO
		76	141	40	XA[9]
		75	142	39	XA[8]
		74	143	38	XA[7]
		73	144	37	XA[6]

(Secondary function)	(Primary)	(Secondary)
NC	108	72
NC	107	71
CKO	106	70
JSEL	105	69
TMS	104	68
TCK	103	67
DRAME_N	102	66
CKOE_N	101	65
GND	100	64
OSCO	99	63
OSCL_N	98	62
VDD_IO	97	61
TEST	96	60
SIN	95	59
SOUT	94	58
AVDD	93	57
VREF	92	56
AIN[0]	91	55
AIN[1]	90	54
AIN[2]	89	53
AIN[3]	88	52
NC	87	51
AGND	86	50
GND	85	49
CTS	84	48
PIOA[2]	83	47
VDD_IO	82	46
DSR	81	45
DCD	80	44
VDD_CORE	79	43
DTR	78	42
RTS	77	41
RI	76	40
GND	75	39
SDA	74	38
SCL	73	37
STXD		

(Primary)	(Secondary)
NC	SRXD
PIOB[7]	
FWR	
RESET_N	
VDD_IO	
XD[0]	
XD[1]	
XD[2]	
XD[3]	
XD[4]	
GND	
NC	
XD[5]	
XD[6]	
GND	
XD[7]	
NC	
VDD_IO	
XD[8]	
XD[9]	
XD[10]	
VDD_COR	
NC	
XD[11]	
XD[12]	
VDD_IO	
XD[13]	
XD[14]	
XD[15]	
XA[0]	
XA[1]	
XA[2]	
XA[3]	
GND	
XA[4]	
XA[5]	

144pin LQFP  
(TOP VIEW)

Notes: NC pins are electrically unconnected in the package.  
NC pins can be connected to Vdd or GND.

## LIST OF PINS

Pin		Primary Function			Secondary Function		
LQFP	BGA	Symbol	I/O	Description	Symbol	I/O	Description
1	A1	NC	—	NC	—	—	
2	B1	PIOB[7]	I/O	General port (with interrupt function)	SRXD	I	SIO receive signal
3	C3	FWR	I	Test mode	—	—	
4	C1	RESET_N	I	Reset input	—	—	
5	D3	VDD_IO	VDD	IO power supply	—	—	
6	C2	XD[0]	I/O	External data bus	—	—	
7	D1	XD[1]	I/O	External data bus	—	—	
8	E3	XD[2]	I/O	External data bus	—	—	
9	D2	XD[3]	I/O	External data bus	—	—	
10	E1	XD[4]	I/O	External data bus	—	—	
11	E4	GND	GND	GND	—	—	
12	E2	NC	—	NC	—	—	
13	F1	XD[5]	I/O	External data bus	—	—	
14	F2	XD[6]	I/O	External data bus	—	—	
15	F4	GND	GND	GND	—	—	
16	F3	XD[7]	I/O	External data bus	—	—	
17	G2	NC	—	NC	—	—	
18	G4	VDD_IO	VDD	I/O power supply	—	—	
19	G3	XD[8]	I/O	External data bus	—	—	
20	G1	XD[9]	I/O	External data bus	—	—	
21	H3	XD[10]	I/O	External data bus	—	—	
22	H4	VDD_CORE	VDD	CORE power supply	—	—	
23	H2	NC	—	NC	—	—	
24	J2	XD[11]	I/O	External data bus	—	—	
25	H1	XD[12]	I/O	External data bus	—	—	
26	J4	VDD_IO	VDD	I/O power supply	—	—	
27	K2	XD[13]	I/O	External data bus	—	—	
28	J1	XD[14]	I/O	External data bus	—	—	
29	J3	XD[15]	I/O	External data bus	—	—	
30	K3	XA[0]	O	External address output	—	—	
31	K1	XA[1]	O	External address output	—	—	
32	L2	XA[2]	O	External address output	—	—	
33	K4	XA[3]	O	External address output	—	—	
34	L1	GND	GND	GND	—	—	
35	M2	XA[4]	O	External address output	—	—	
36	M1	XA[5]	O	External address output	—	—	
37	N1	XA[6]	O	External address output	—	—	
38	N2	XA[7]	O	External address output	—	—	
39	L3	XA[8]	O	External address output	—	—	
40	N3	XA[9]	O	External address output	—	—	

Pin		Primary Function			Secondary Function		
LQFP	BGA	Symbol	I/O	Description	Symbol	I/O	Description
41	L4	VDD_IO	VDD	I/O power supply	—	—	
42	M3	XA[10]	O	External address output	—	—	
43	N4	XA[11]	O	External address output	—	—	
44	L5	XA[12]	O	External address output	—	—	
45	M4	XA[13]	O	External address output	—	—	
46	N5	XA[14]	O	External address output	—	—	
47	K5	GND	GND	GND	—	—	
48	M5	XA[15]	O	External address output	—	—	
49	N6	XA[16]	O	External address output	—	—	
50	M6	XA[17]	O	External address output	—	—	
51	K6	GND	GND	GND	—	—	
52	L6	XA[18]	O	External address output	—	—	
53	M7	PIOC[2]	I/O	General port (with interrupt function)	XA[19]	O	External address output
54	K7	VDD_IO	VDD	I/O power supply	—	—	
55	L7	PIOC[3]	I/O	General port (with interrupt function)	XA[20]	O	External address output
56	N7	PIOC[4]	I/O	General port (with interrupt function)	XA[21]	O	External address output
57	L8	PIOC[5]	I/O	General port (with interrupt function)	XA[22]	O	External address output
58	K8	VDD_CORE	VDD	CORE power supply	—	—	
59	M8	PIOC[6]	I/O	General port (with interrupt function)	XA[23]	O	External address output
60	M9	PIOC[7]	I/O	General port (with interrupt function)	XWR	O	Transfer direction of external bus
61	N8	XOE_N	O	Output enable (excluding SDRAM)	—	—	
62	K9	VDD_IO	VDD	I/O power supply	—	—	
63	M10	XWE_N	O	Write enable	—	—	
64	N9	XBWE_N[0]	O	Byte write enable (LSB)	—	—	
65	L9	XBWE_N[1]	O	Byte write enable (MSB)	—	—	
66	L10	XROMCS_N	O	External ROM chip select	—	—	
67	N10	XRAMCS_N	O	External RAM chip select	—	—	
68	M11	XIOCS_N[0]	O	IO chip select 0	—	—	
69	K10	GND	GND	GND	—	—	
70	N11	XIOCS_N[1]	O	IO chip select 1	—	—	
71	M12	XIOCS_N[2]	O	IO chip select 2	—	—	
72	N12	XIOCS_N[3]	O	IO chip select 3	—	—	
73	N13	PIOD[6]	I/O	General port (with interrupt function)	XDQM[1]/XCAS_N[1]	O	INPUT/OUTPUT mask/CAS (MSB)
74	M13	PIOD[7]	I/O	General port (with interrupt function)	XDQM[0]/XCAS_N[0]	O	INPUT/OUTPUT mask/CAS (LSB)
75	L11	PIOB[0]	I/O	General port (with interrupt function)	DREQ[0]	I	DMA request signal (CH0)
76	L13	PIOB[1]	I/O	General port (with interrupt function)	DREQCLR[0]	O	DREQ Clear Signal (CH0)
77	K11	VDD_IO	VDD	I/O power supply	—	—	
78	L12	PIOB[2]	I/O	General port (with interrupt function)	DREQ[1]	I	DMA request signal (CH1)

Pin		Primary Function			Secondary Function		
LQFP	BGA	Symbol	I/O	Description	Symbol	I/O	Description
79	K13	PIOB[3]	I/O	General port (with interrupt function)	DREQCLR[1]	O	DREQ Clear Signal (CH1)
80	J11	PIOB[4]	I/O	General port (with interrupt function)	TCOUT[0]	O	DMAC Terminal Count (CH0)
81	K12	PIOB[5]	I/O	General port (with interrupt function)	TCOUT[1]	O	DMAC Terminal Count (CH1)
82	J13	PIOC[0]	I/O	General port (with interrupt function)	PWMOUT[0]	O	PWM output (CH0)
83	J10	PIOC[1]	I/O	General port (with interrupt function)	PWMOUT[1]	O	PWM output (CH1)
84	J12	GND	GND	GND	—	—	
85	H13	XBS_N[0]	O	External bus byte select (LSB)	—	—	
86	H12	XBS_N[1]	O	External bus byte select (MSB)	—	—	
87	H10	VDD_CORE	VDD	CORE power supply	—	—	
88	H11	PIOD[0]	I/O	General port (with interrupt function)	XWAIT	I	Wait input signal for I/O Banks
89	G12	PIOD[1]	I/O	General port (with interrupt function)	XCAS_N	O	Column address strobe (SDRAM)
90	G10	GND	GND	GND	—	—	
91	G11	VDD_IO	VDD	I/O power supply	—	—	
92	G13	PIOD[2]	I/O	General port (with interrupt function)	XRAS_N	O	Row address strobe (SDRAM/EDO)
93	F11	PIOD[3]	I/O	General port (with interrupt function)	XSDCLK	O	Clock for SDRAM
94	F10	PIOD[4]	I/O	General port (with interrupt function)	XSDCS_N	O	Chip select for SDRAM
95	F12	PIOD[5]	I/O	General port (with interrupt function)	XSDCKE	O	Clock enable (SDRAM)
96	E12	BSEL[0]	I	Select boot device	—	—	
97	F13	BSEL[1]	I	Select boot device	—	—	
98	E10	PIOE[5]	I/O	General port (with interrupt function)	EXINT[0]	I	Interrupt input
99	D12	PIOE[6]	I/O	General port (with interrupt function)	EXINT[1]	I	Interrupt input
100	E13	PIOE[7]	I/O	General port (with interrupt function)	EXINT[2]	I	Interrupt input
101	E11	PIOE[8]	I/O	General port (with interrupt function)	EXINT[3]	I	Interrupt input
102	D11	PIOE[9]	I/O	General port (with interrupt function)	EFIQ_N	I	FIQ input
103	D13	PIOE[0]	I/O	General port (with interrupt function)	SCLK	I/O	SSIO clock
104	C12	PIOE[1]	I/O	General port (with interrupt function)	SDI	I	SSIO Serial Data In
105	D10	PIOE[2]	I/O	General port (with interrupt function)	SDO	O	SSIO Serial Data Out
106	C13	TDI	I	JTAG data Input	—	—	
107	B12	TDO	O	JTAG data out	—	—	
108	B13	nTRST	I	JTAG reset	—	—	
109	A13	NC	—	NC	—	—	
110	A12	NC	—	NC	—	—	
111	C11	CKO	O	Clock output	—	—	
112	A11	JSEL	I	JTAG select	—	—	
113	C10	TMS	I	JTAG mode select	—	—	
114	B11	TCK	I	JTAG clock	—	—	
115	A10	DRAME_N	I	DRAM enable	—	—	



Pin		Primary Function			Secondary Function		
LQFP	BGA	Symbol	I/O	Description	Symbol	I/O	Description
116	C9	CKOE_N	I	Clock out enable	—	—	
117	B10	GND	GND	GND	—	—	
118	A9	OSC0	I	Oscillation input pin	—	—	
119	D9	OSC1_N	O	Oscillation output pin	—	—	
120	B9	VDD_IO	VDD	IO power supply	—	—	
121	A8	TEST	I	Test mode input	—	—	
122	B8	PIOA[0]	I/O	General port (with interrupt function)	SIN	I	UART Serial Data In
123	D8	PIOA[1]	I/O	General port (with interrupt function)	SOUT	O	UART Serial Data Out
124	C8	AVDD	VDD	A/D CONVERTER power supply	—	—	
125	B7	VREF	I	A/D CONVERTER Reference voltage	—	—	
126	D7	AIN[0]	I	A/D CONVERTER analog input port	—	—	
127	C7	AIN[1]	I	A/D CONVERTER analog input port	—	—	
128	A7	AIN[2]	I	A/D CONVERTER analog input port	—	—	
129	C6	AIN[3]	I	A/D CONVERTER analog input port	—	—	
130	D6	NC	—	NC	—	—	
131	B6	AGND	GND	GND for A/D CONVERTER	—	—	
132	B5	GND	GND	GND	—	—	
133	A6	PIOA[2]	I/O	General port (with interrupt function)	CTS	I	UART Clear To Send
134	D5	VDD_IO	VDD	IO power supply	—	—	
135	B4	PIOA[3]	I/O	General port (with interrupt function)	DSR	I	UART Set Ready
136	A5	PIOA[4]	I/O	General port (with interrupt function)	DCD	I	UART Carrier Detect
137	C5	VDD_CORE	VDD	CORE power supply	—	—	
138	C4	PIOA[5]	I/O	General port (with interrupt function)	DTR	O	UART Data Terminal Ready
139	A4	PIOA[6]	I/O	General port (with interrupt function)	RTS	O	UART Request To Send
140	B3	PIOA[7]	I/O	General port (with interrupt function)	RI	I	UART Ring Indicator
141	D4	GND	GND	GND	—	—	
142	A3	PIOE[3]	I/O	General port (with interrupt function)	SDA	I/O	I2C Data In/Out
143	B2	PIOE[4]	I/O	General port (with interrupt function)	SCL	O	I2C Clock out
144	A2	PIOB[6]	I/O	General port (with interrupt function)	STXD	O	SIO send data output

## PIN DESCRIPTION

Pin Name	I/O	Description	Primary/ Secondary	Logic
System				
RESET_N	I	Reset input	—	Negative
BSEL[1:0]	I	Boot device select signal BSEL[1] BSEL[0] Boot device 0 0 Internal Flash (External ROM for ML674001) 0 1 External ROM 1 * Boot mode The selected device is mapped to BANK0 (0x0000_0000 - 0x07FF_FFFF) after reset.	—	Positive
OSC0	I	Crystal connection or external clock input. Connect a crystal (16 MHz to 33 MHz), if used, to OSC0 and OSC1_N. It is also possible to input a direct clock.	—	—
OSC1_N	O	Crystal connection. When not using a crystal, leave this pin unconnected.	—	—
CKO	O	Clock out	—	—
CKOE_N	I	Clock out enable	—	Negative
Debugging support.				
TCK	I	Debugging pin. Normally connect to ground level.	—	—
TMS	I	Debugging pin. Normally drive at High level.	—	Positive
nTRST	I	Debugging pin. Normally connect to ground level.	—	Negative
TDI	I	Debugging pin. Normally drive at High level.	—	Positive
TDO	O	Debugging pin. Normally leave open.	—	Positive
General-purpose I/O ports				
PIOA[7:0]	I/O	General-purpose port. Not available for use as port pins when secondary functions are in use.	Primary	Positive
PIOB[7:0]	I/O	General-purpose port. Not available for use as port pins when secondary functions are in use.	Primary	Positive
PIOC[7:0]	I/O	General-purpose port. Not available for use as port pins when secondary functions are in use.	Primary	Positive
PIOD[7:0]	I/O	General-purpose port. Not available for use as port pins when secondary functions are in use. Note that enabling DRAM controller with DRAME_N inputs permanently configures PIOD[7:0] for their secondary functions, making them unavailable for use as port pins.	Primary	Positive
PIOE[9:0]	I/O	General-purpose port. Not available for use as port pins when secondary functions are in use.	Primary	Positive

Pin Name	I/O	Description	Primary / Secondary	Logic
<b>External Bus</b>				
XA[23:19]	O	Address bus to external RAM, external ROM, external I/O banks, and external DRAM. After a reset, these pins are configured for their primary function (PIOC[6:2]).	Secondary	Positive
XA[18:0]	O	Address bus to external RAM, external ROM, external I/O banks, and external DRAM.	—	Positive
XD[15:0]	I/O	Data bus to external RAM, external ROM, external I/O banks, and external DRAM.	—	Positive
<b>External bus control signals (ROM/SRAM/I/O)</b>				
XROMCS_N	O	ROM bank chip select	—	Negative
XRAMCS_N	O	SRAM bank chip select	—	Negative
XIOCS_N[0]	O	IO chip select 0	—	Negative
XIOCS_N[1]	O	IO chip select 1	—	Negative
XIOCS_N[2]	O	IO chip select 2	—	Negative
XIOCS_N[3]	O	IO chip select 3	—	Negative
XOE_N	O	Output enable/ Read enable	—	Negative
XWE_N	O	Write enable	—	Negative
XBS_N[1:0]	O	Byte select: XBS_N[1] is for MSB, XBS_N[0] is for LSB	—	Negative
XBWE_N[0]	O	LSB Write enable	—	Negative
XBWE_N[1]	O	MSB Write enable	—	Negative
XWR	O	Data transfer direction for external bus, used when connecting to Motorola I/O devices. This represent the secondary function of pin PIOC[7]. L: read , H: write. Available for I/O bank 0/1.	Secondary	—
XWAIT	I	External I/O bank 0/1, 2/3 WAIT signal. This input permits access to devices slower than register settings.	Secondary	Positive
<b>External bus control signals (DRAM)</b>				
XRAS_N	O	Row address strobe. Used for both EDO DRAM and SDRAM	Secondary	Negative
XCAS_N	O	Column address strobe signal (SDRAM)	Secondary	Negative
XSDCLK	O	SDRAM clock (same frequency as internal HCLK)	Secondary	—
XSDCKE	O	Clock enable (SDRAM)	Secondary	—
XSDCS_N	O	Chip select (SDRAM)	Secondary	Negative
XDQM[1]/XCAS_N[1]	O	Connected to SDRAM: DQM (MSB) Connected to EDO DRAM: column address strobe signal (MSB)	Secondary	Positive/ Negative
XDQM[0]/XCAS_N[0]	O	Connected to SDRAM: DQM (LSB) Connected to EDO DRAM: column address strobe signal (LSB)	Secondary	Positive/ Negative

Pin Name	I/O	Description	Primary / Secondary	Logic
<b>DMA control signals</b>				
DREQ[0]	I	Ch 0 DMA request signal, used when DMA controller configured for DREQ type	Secondary	Positive
DREQCLR[0]	O	Ch 0 DREQ signal clear request. The DMA device responds to this output by negating DREQ.	Secondary	Positive
TCOUT[0]	O	Indicates to Ch 0 DMA device that last transfer has started.	Secondary	Positive
DREQ[1]	I	Ch 1 DMA request signal, used when DMA controller configured for DREQ type	Secondary	Positive
DREQCLR[1]	O	Ch 1 DREQ signal clear request. The DMA device responds to this output by negating DREQ.	Secondary	Positive
TCOUT[1]	O	Indicates to Ch 1 DMA device that last transfer has started	Secondary	Positive
<b>UART</b>				
SIN	I	SIO receive signal	Secondary	Positive
SOUT	O	SIO transmit signal	Secondary	Positive
CTS	I	Clear To Send. Indicates that modem or data set is ready to transfer data. Bit 4 in modem status register reflects this input.	Secondary	Negative
DSR	I	Data Set Ready. Indicates that modem or data set is ready to establish a communications link with UART. Bit 5 in modem status register reflects this input.	Secondary	Negative
DCD	I	Data Carrier Detect. Indicates that modem or data set has detected data carrier signal. Bit 7 in modem status register reflects this input. Data Carrier Detect	Secondary	Negative
DTR	O	Data Terminal Ready. Indicates that UART is ready to establish a communications link with modem or data set. Bit 0 in modem control register controls this output.	Secondary	Negative
RTS	O	Request To Send. Indicates that UART is ready to transfer data to modem or data set. Bit 1 in modem control register controls this output.	Secondary	Negative
RI	I	Ring Indicator. Indicates that modem or data set has received telephone ring indicator. Bit 6 in modem status register reflects this input.	Secondary	Negative

Pin Name	I/O	Description	Primary / Secondary	Logic
<b>SIO</b>				
STXD	O	SIO transmit signal	Secondary	Positive
SRXD	I	SIO receive signal	Secondary	Positive
<b>I2C</b>				
SDA	I/O	I2C Data. This pin operates as NMOS Open drain. Connect pull-up resistor.	Secondary	Positive
SCL	O	I2C Clock. This pin operates as NMOS Open drain. Connect pull-up resistor.	Secondary	—
<b>Synchronous SIO</b>				
SCLK	I/O	Serial clock	Secondary	—
SDI	I	Serial receive data	Secondary	Positive
SDO	O	Serial transmit data	Secondary	Positive
<b>PWM signals</b>				
PWMOUT[0]	O	PWM output of CH0	Secondary	Positive
PWMOUT[1]	O	PWM output of CH1	Secondary	Positive
<b>Analog-to-digital converter</b>				
AIN[0]	I	Ch0 analog input	—	—
AIN[1]	I	Ch1 analog input	—	—
AIN[2]	I	Ch2 analog input	—	—
AIN[3]	I	Ch3 analog input	—	—
VREF	I	Analog-to-digital converter convert reference voltage	—	—
AVDD		Analog-to-digital converter power supply	—	—
AGND		Analog-to-digital converter ground	—	—
<b>Interrupt signals</b>				
EXINT[3:0]	I	External interrupt input signals.	Secondary	Positive / Negative
EFIQ_N	I	External fast interrupt input signal. Interrupt controller connects this to CPU FIQ input.	Secondary	Negative
<b>MODE configuration</b>				
DRAME_N	I	DRAM enable mode	—	Negative
TEST	I	Test mode	—	Positive
FWR	I	Test mode	—	Positive
JSEL	I	JTAG select signal. L: On-board debug, H: Boundary scan.	—	—
<b>Power supplies</b>				
VDD_CORE		Core power supply	—	—
VDD_IO		I/O power supply	—	—
GND		GND for core and I/O	—	—

**DESCRIPTION OF FUNCTIONS****CPU**

CPU core:	ARM7TDMI
Operating frequency:	1 MHz to 33 MHz
Byte ordering:	Little endian
Instructions:	ARM instruction (32-bit length) and Thumb instruction (16-bit length) can be mixed.
General register bank:	31 × 32 bits
Built-in barrel shifter:	ALU and barrel shift operations can be executed by one instruction.
Multiplier:	32 bits × 8 bits (Modified Booth's Algorithm)
Built-in debug function:	JTAG interface, break point register

**Built-in Memory****FLASH ROM:**

ML674001 :	ROM-less version
ML67Q4002 :	256Kbytes (128K x 16 bits)
ML67Q4003 :	512Kbytes (256K x 16 bits)
Access timing of this FLASH memory is configured by the ROM bank control register of the external memory controller.	

RAM:	32KB (8K x 32bits)
	Read access(8/16/32bit): 1 cycle,
	Write access(32bit): 1 cycle,
	Write access(8/16bit): 2 cycle,

**Interrupt Controller**

Fast interrupt request (FIQ) and interrupt request (IRQ) are employed as interrupt input signals. The interrupt controller controls these interrupt signals going to ARM core.

- (1) Interrupt sources
  - FIQ: 1 external source (external pin: EFIQ\_N)
  - IRQ: total of 27 sources. 23 internal sources, and 4 external sources (external pins: EXINT[3:0])
- (2) Interrupt priority level
  - Configurable, 8-level priority for each source
- (3) External interrupt pin input
  - EXINT[3:0] can be set as Level or Edge sensing.
  - Configurable High or Low when Level sensing. Configurable Rise or Falling edge triggering when Edge sensing.
  - EFIQ\_N is set as Falling edge triggering.

**Timers**

7 channels of 16-bit reload timers are employed. Of these, 1 channel is used as system timer for OS. The timers of other 6 channels are used in application software.

- (1) System timer: 1 channel
  - 16-bit auto reload timer: Used as system timer for OS. Interrupt request by timer overflow.
- (2) Application timer: 6 channels
  - 16-bit auto reload timer. Interrupt request by compare match.
  - One shot, interval
  - Clock can be independently set for each channel

**WDT**

Functions as an interval timer or a watch dog timer.

- (1) 16-bit timer
- (2) Watch dog timer or interval timer mode can be selected
- (3) Interrupt or reset generation.
- (4) Maximum period: longer than 200 msec

**PWM**

This LSI contains two channels of PWM (Pulse Width Modulation) function which can change the duty cycle of a waveform with a constant period. The PWM output resolution is 16 bits for each channel.

**Serial Interface**

This LSI contains four serial interface.

- (1) UART without FIFO : 1 channel  
 This is the serial port which performs data transmission, taking a synchronization per character.  
 Selection of various parameters, such as addition of data length, a stop bit, and a parity bit, is possible.
  - Asynchronous full duplex operation
  - Sampling Rate = Baud rate x 16sample
  - Character Length : 7, 8 bit
  - Stop Bit Length : 1, 2 bit
  - Parity : Even, Odd, none
  - Error Detection : Parity, Framing, Over run
  - Loop Back Function : ON/OFF, Parity, framing, Over run Compulsive addition
  - Baud Rate Generation : Exclusive baud rate generator built-in (8bit counter)  
Independent from a bus clock
  - Internal-Baud-Rate-Clock-Stop at the time of HALT Mode.
- (2) UART with 16bytes FIFO : 1channel  
 Features 16bytes FIFO in both send and receive. Uses the industry standard 16550A ACE (Asynchronous Communication Element).
  - Asynchronous full duplex operation
  - Reporting function for all status
  - 16 Byte Transmission and reception FIFO
  - Transmission, reception, interrupt of line status Data set and Independent FIFO control.
  - Modem control signals : CTS, DCD, DSR, DTR, RI and RTS
  - Data length : 5, 6, 7, 8 bit
  - Stop bit length : 1, 1.5, 2 bit
  - parity : Even, Odd, none
  - Error Detection : Parity, Framing, Overrun
  - Baud Rate Generation : Exclusive baud rate generator built-in
- (3) Synchronous serial interface : 1channel  
 It is a clock synchronous 8bit serial port
  - selectable 1/8, 1/16 or 1/32 of HCLK frequency.
  - Choose LSB First or MSB First.
  - Choose Master / Slave Mode
  - Transceiver Interruption, Transceiver buffer empty interrupt
  - Loopback Test Function
- (4) I2C : 1channel  
 Based on the I2C BUS specifications. Operates as a single master device.
  - Communication mode : Master transmitter /master receiver
  - Transmission Speed : 100kbps (Standard mode) / 400kbps (Fast mode)
  - Addressing format : 7 bit / 10 bit
  - Data buffer : 1 Byte(1step)
  - Communication Voltage : 2.7V to 3.3V

**GPIO**

42-bits parallel port (four 8-bit ports and one 10-bit port).

PIOA[7:0]	Combination port	UART
PIOB[7:0]	Combination port	DMAC, UART(uPLAT-7B),
PIOC[7:0]	Combination port	PWM, XA[23:19], XWR
PIOD[7:0]	Combination port	DRAM control signal etc.
PIOE[9:0]	Combination port	SSIO, I2C, External interrupt signal

- (1) Input/output selectable at bit level.
- (2) Each bit can be used as an interrupt source.
- (3) Interrupt mask and interrupt polarity can be set for all bits.
- (4) The ports are configured as input, immediately after reset.
- (5) Primary/secondary function of each port can be set independently.

**AD Converter**

Successive approximation type AD converter.

- (1) 10 bits × 4 channels
- (2) Sample hold function
- (3) Scan mode and select mode are supported
- (4) Interrupt is generated after completion of conversion.
- (5) Conversion time: 5 μs minimum.

**DMAC**

Two channels of direct memory access controller which transfers data between memory and memory, between I/O and memory and between I/O and I/O.

- (1) Number of channels: 2 channels
- (2) Channel priority level: Fixed mode
  - Channel priority level is always fixed (channel 0 > 1).
  - Roundrobin
    - Priority level of the channel requested for transfer is kept lowest.
- (3) Maximum number of transfers: 65,536 times (64K times)
- (4) Data transfer size: Byte (8 bits), half-word (16 bits), word (32 bits)
- (5) Bus request system: Cycle steal mode
  - Bus request signal is asserted for each DMA transfer cycle.
  - Burst mode
    - Bus request signal is asserted until all transfers of transfer cycles are complete.
- (6) DMA transfer request: Software request
  - By setting the software transfer request bit inside DMAC, the CPU starts DMA transfer.
  - External request
    - DMA transfer is started by external request allocated to each channel.
- (7) Interrupt request: Interrupt request is generated to CPU after the end of DMA transfers for the set number of transfer cycles or after occurrence of error.
  - Interrupt request signal is output separately for each channel.
  - Interrupt request signal output can be masked for each channel.



**External memory controller**

Controls access of externally connected devices such as ROM (FLASH), SRAM, SDRAM (EDO DRAM), IO devices, and internal FLASH memory.

- (1) ROM (FLASH) access function : 1 bank  
 Supports 16-bit devices.  
 Supports FLASH memory: Byte write (can be written only by IF equivalent to SRAM).  
 In ML67Q4002/ML67Q4003, control internal FLASH access.  
 Configurable access timing.
- (2) SRAM access function : 1 bank  
 Supports 16-bit devices.  
 Supports asynchronous SRAM  
 Configurable access timing.
- (3) DRAM access function : 1 bank  
 Supports 16-bit device  
 Supports EDO/SDRAM : Simultaneous connections to EDO-DRAM and SDRAM cannot be made.  
 Configurable access timing.
- (4) External IO access function : 2 banks  
 Supports 8-bit/16-bit access : Independent configuration for each bank  
 Each bank has two chip selects : XIOCS\_N[3:0]  
 Supports external wait input : XWAIT  
 Access Timing configurable for each bank independently

**Power Management**

HALT, STANDBY, clock gear, clock control functions are supported as power save functions.

- (1) HALT mode  
 HALT object  
     CPU, internal RAM, AHB bus control  
 HALT mode setting: Set by the system control register.  
 Exit HALT mode due to: Reset, interrupt
- (2) STANDBY mode  
 Stops the clock of entire LSI.  
 STANDBY mode setting: Specified by the system control register.  
 Exit STANDBY mode due to: Reset, external interrupt (other than EFIQ\_N)
- (3) Clock gear  
 This LSI has two clock systems, HCLK and CCLK. Configure HCLK and CCLK frequency.  
 HCLK: CPU, bus control, synchronous serial interface, I2C.  
 CCLK: Timers, PWM, UART, AD converter, etc.
- (4) Clock control by each function unit  
 AD converter, PWM, Timers, DRAMC, DMAC, UART(FIFO), UART, Synchronous SIO, I2C.

## BUILT-IN FLASH ROM PROGRAMMING

The robust features of the flash permit simple and optimized programming as well as maintaining the flash-ROM.

### (1) Programming Method

- Programming via JTAG interface
- Programming using boot mode

Boot mode of this LSI is used for downloading data to be written to the FLASH through the UART interface of the MCU from a host system. In boot mode, the program on the on-chip boot ROM downloads a flash writing application, that will handle the serial transfer and writing of internal flash, to internal RAM area of the MCU through the UART interface of the MCU.

- Programming via user application running from external memory  
Internal flash can be programmed by executing a user flash programming application from external memory.

### (2) Single power source for Read/Program of FLASH: 3.0V to 3.6V

### (3) Programming units : 2 bytes

### (4) Selectable erasing size

- Sector erase: 2Kbytes/sector
- Block erase: 64Kbytes/block
- Chip erase: All memory cell

### (5) Word program time: 30usec

### (6) Sector/block erase time: 25msec

### (7) Chip erase time: 100msec

### (8) Write protection

- Block protect: top address 8Kwords can be protected
- Chip protect: all words can be protected

### (9) Number of commands: 9

### (10) Highly reliable read/program

- Sector programming: 1000 times
- Data hold period: 10 years

**ABSOLUTE MAXIMUM RATINGS\*<sup>1</sup>**

Item	Symbol	Conditions	Rating	Unit
Digital power supply voltage (core)	$V_{DD\_CORE}$	GND = AGND = 0 V $T_a = 25^\circ\text{C}$	-0.3 to +3.6	V
Digital power supply voltage (I/O)	$V_{DD\_IO}$		-0.3 to +4.6	
Input voltage	$V_I$		-0.3 to $V_{DD\_IO}+0.3$	
Output voltage	$V_O$		-0.3 to $V_{DD\_IO}+0.3$	
Analog power supply voltage	$AV_{DD}$		-0.3 to $V_{DD\_IO}+0.3$	
Analog reference voltage	$V_{REF}$		-0.3 to $V_{DD\_IO}+0.3$ and -0.3 to $AV_{DD} +0.3$	
Analog input voltage	$V_{AI}$		-0.3 to $V_{REF}$	
Input current	$I_I$	—	-10 to +10	mA
Output current * <sup>2</sup>	$I_O$		-20 to +20	
Output current * <sup>3</sup>			-30 to +30	
Power losses (LFBGA)	$P_D$	$T_a = 85^\circ\text{C}$	680	mW
Power losses (LQFP)		per package	1000	
Storage temperature	$T_{STG}$	—	-50 to +150	$^\circ\text{C}$

**Note**

1. These are maximum ratings not for general operation. Exceeding these maximum ratings could cause damage or lead to permanent deterioration of the device.
2. All output pins except XA[15:0]
3. XA[15:0]

**OPERATING CONDITIONS**

(GND = 0 V)

Item	Symbol	Conditions	Minimum	Typical	Maximum	Unit
Digital power supply voltage (core)	$V_{DD\_CORE}$	$V_{DD\_IO} \geq V_{DD\_CORE}$	2.25	2.5	2.75	V
Digital power supply voltage (I/O)	$V_{DD\_IO}$		3.0	3.3	3.6	
Analog power supply voltage	$AV_{DD}$	$AV_{DD} = V_{DD\_IO}$	3.0	3.3	3.6	
Analog reference voltage	$V_{REF}$	$V_{REF} = AV_{DD} = V_{DD\_IO}$	3.0	3.3	3.6	
Operating frequency *	$f_{OP}$	$V_{DD\_CORE} = 2.25$ to $2.75$ $V_{DD\_IO} = 3.0$ to $3.6$	1	—	33.333	MHz
Ambient temperature	$T_a$	—	-40	25	+85	$^\circ\text{C}$

**Note**

Operating frequencies between 16 MHz and 33 MHz. Minimum of 2.56 MHz for external SDRAM. Minimum of 6.4 MHz for external EDO DRAM. Minimum of 2 MHz for analog-to-digital converter.

## ELECTRICAL CHARACTERISTICS

### DC Characteristics

( $V_{DD\_CORE} = 2.25$  to  $2.75$ V,  $V_{DD\_IO} = 3.0$  to  $3.6$ V,  $T_a = -40$  to  $+85^\circ\text{C}$ )

Item	Symbol	Conditions	Minimum	Typical	Maximum	Unit	
High level input voltage	$V_{IH}$	—	$V_{DD\_IO} \times 0.8$	—	$V_{DD\_IO} + 0.3$	V	
Low level input voltage	$V_{IL}$		-0.3	—	$V_{DD\_IO} \times 0.2$		
Schmitt input buffer threshold voltage	$V_{T+}$		—	—	1.6		2.1
	$V_{T-}$		0.7	1.1	—		
	$V_{HYS}$		0.4	0.5	—		
High level output voltage	$V_{OH}$		$I_{OH} = -100 \mu\text{A}$	$V_{DD} - 0.2$	—		—
		$I_{OH} = -4 \text{ mA}$	2.35	—	—		
Low level output voltage	$V_{OL}$	$I_{OL} = 100 \mu\text{A}$	—	—	0.2		
Low level output voltage *1		$I_{OL} = 4 \text{ mA}$	—	—	0.45		
Low level output voltage *2		$I_{OL} = 6 \text{ mA}$	—	—	0.45		
Input leak current *3	$I_{IH}/I_{IL}$	$V_I = 0 \text{ V}/V_{DD\_IO}$	-50	—	50	$\mu\text{A}$	
Input leak current *4	$I_{IL}$	$V_I = 0 \text{ V}$ Pull-up resistance of $50 \text{ k}\Omega$	-200	-66	-10		
Input leak current *5	$I_I$	$V_I = AV_{DD} / 0 \text{ V}$	-5	—	5		
Output leak current	$I_{LO}$	$V_O = 0 \text{ V}/V_{DD\_IO}$	-50	—	50		
Input pin capacitance	$C_I$	—	—	6	—		pF
Output pin capacitance	$C_O$	—	—	9	—		
I/O pin capacitance	$C_{IO}$	—	—	10	—		
Analog reference power supply current	$I_{REF}$	Analog-to-digital converter operative *6	—	320	650	$\mu\text{A}$	
		Analog-to-digital converter stopped	—	1	2		
Current consumption (STANDBY)	$I_{DD\_CORE}$	$T_a = 25^\circ\text{C}$ *7	—	20	100	$\mu\text{A}$	
	$I_{DD\_IO}$		—	5	20		
Current consumption (HALT) *8	$I_{DDH\_CORE}$	$f_{OP} = 33 \text{ MHz}$ $C_L = 30 \text{ pF}$	—	20	40	mA	
	$I_{DDH\_IO}$		—	5	10		
Current consumption (RUN) *9	$I_{DD\_CORE}$		—	40	70		
	$I_{DD\_IO}$		—	18	30		

#### Notes

1. All output pins except XA[15:0]
2. XA[15:0]
3. All input pins except RESET\_N
4. RESET\_N pin, with  $50 \text{ k}\Omega$  pull-up resistance
5. Analog input pins (AIN0 to AIN3)
6. Analog-Digital Converter operation ratio is 20%
7.  $V_{DD\_IO}$  or  $0 \text{ V}$  for input ports; no load for other pins
8. DRAM controller blocks stopped by DRAME\_N pin setting
9. External ROM used

**Analog-to-Digital Converter Characteristics** $(V_{DD\_CORE} = 2.50\text{ V}, V_{DD\_IO} = 3.3\text{ V}, T_a = 25^\circ\text{C})$ 

Item	Symbol	Conditions	Minimum	Typical	Maximum	Unit
Resolution	n	—	—	—	10	bit
Linearity error	$E_L$	Analog input source impedance $R_i \leq 1\text{k}\Omega$	—	$\pm 3$	—	LSB
Differential linearity error	$E_D$		—	$\pm 3$	—	
Zero scale error	$E_{ZS}$		—	$\pm 3$	—	
Full scale error	$E_{FS}$		—	$\pm 3$	—	
Conversion time	$t_{CONV}$	—	5	—	—	$\mu\text{s}$
Throughput		—	10	—	200	kHz

Notes: VDD\_IO and AVDD should be supplied separately

- Definition of Terms

- (1) Resolution: Minimum input analog value recognized. For 10-bit resolution, this is  $(V_{REF} - A_{ground}) \div 1024$ .
- (2) Linearity error: Difference between the theoretical and actual conversion characteristics. (Note that it does not include quantization error.) The theoretical conversion characteristic divides the voltage range between  $V_{REF}$  and  $AGND$  into 1024 equal steps.
- (3) Differential linearity error: Difference between the theoretical and actual input voltage change producing a 1-bit change in the digital output anywhere within the conversion range. This is an indicator of conversion characteristic smoothness. The theoretical value is  $(V_{REF} - A_{ground}) \div 1024$ .
- (4) Zero scale error: Difference between the theoretical and actual conversion characteristics at the point where the digital output switches from “0x000” to “0x001.”
- (5) Full scale error: Difference between the theoretical and actual conversion characteristics at the point where the digital output switches from “0x3FE” to “0x3FF.”

**PACKAGE DIMENSIONS**

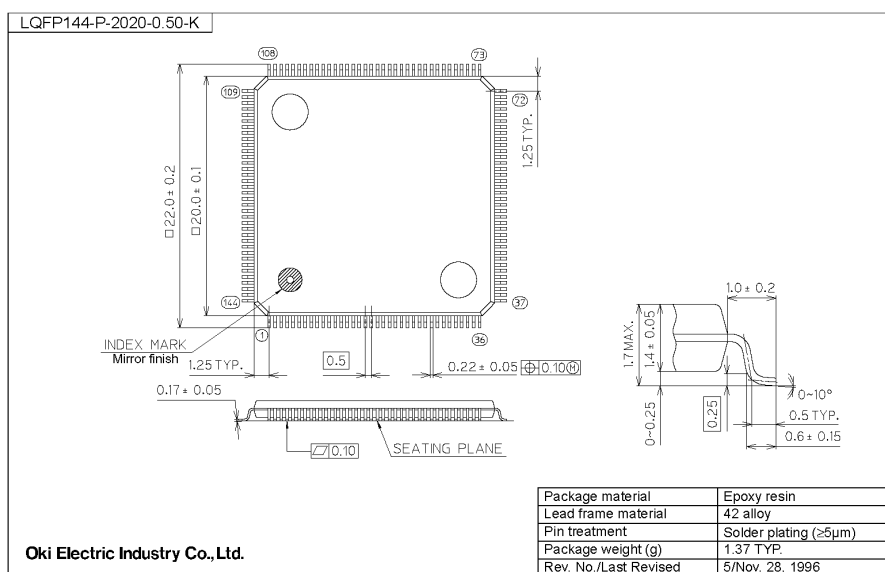
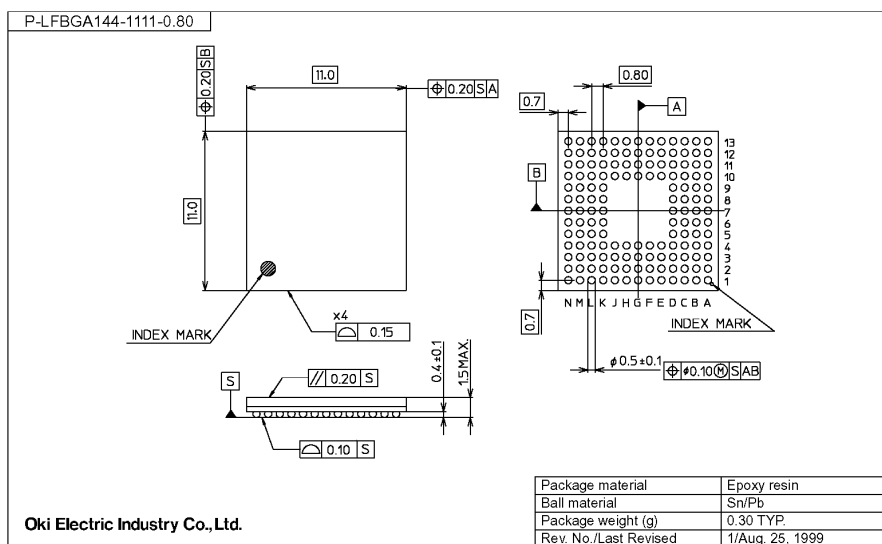

**Notes for Mounting the Surface Mount Type Package**

The surface mount type packages are very susceptible to heat in reflow mounting and humidity absorbed in storage.

Therefore, before you perform reflow mounting, contact Oki's responsible sales person for the product name, package name, pin number, package code and desired mounting conditions (reflow method, temperature and times).

**REVISION HISTORY**

Document No.	Date	Page		Description
		Previous Edition	Current Edition	
PEDL674001-01	Jan.15, 2003	–	–	Preliminary edition 1
PEDL674001-02	Feb.17, 2003	3	3	Preliminary edition 2 Modified PIOB[4:5] assignment of bloc diagram
FEDL674001-01	Dec. 15, 2003	–	–	Final edition 1

**NOTICE**

1. The information contained herein can change without notice owing to product and/or technical improvements. Before using the product, please make sure that the information being referred to is up-to-date.
2. The outline of action and examples for application circuits described herein have been chosen as an explanation for the standard action and performance of the product. When planning to use the product, please ensure that the external conditions are reflected in the actual circuit, assembly, and program designs.
3. When designing your product, please use our product below the specified maximum ratings and within the specified operating ranges including, but not limited to, operating voltage, power dissipation, and operating temperature.
4. Oki assumes no responsibility or liability whatsoever for any failure or unusual or unexpected operation resulting from misuse, neglect, improper installation, repair, alteration or accident, improper handling, or unusual physical or electrical stress including, but not limited to, exposure to parameters beyond the specified maximum ratings or operation outside the specified operating range.
5. Neither indemnity against nor license of a third party's industrial and intellectual property right, etc. is granted by us in connection with the use of the product and/or the information and drawings contained herein. No responsibility is assumed by us for any infringement of a third party's right which may result from the use thereof.
6. The products listed in this document are intended for use in general electronics equipment for commercial applications (e.g., office automation, communication equipment, measurement equipment, consumer electronics, etc.). These products are not, unless specifically authorized by Oki, authorized for use in any system or application that requires special or enhanced quality and reliability characteristics nor in any system or application where the failure of such system or application may result in the loss or damage of property, or death or injury to humans.  
Such applications include, but are not limited to, traffic and automotive equipment, safety devices, aerospace equipment, nuclear power control, medical equipment, and life-support systems.
7. Certain products in this document may need government approval before they can be exported to particular countries. The purchaser assumes the responsibility of determining the legality of export of these products and will take appropriate and necessary steps at their own expense for these.
8. No part of the contents contained herein may be reprinted or reproduced without our prior permission.

Copyright 2003 Oki Electric Industry Co., Ltd.