

# AC Controller Modules

## ECO-PAC 2

**$I_{RMS} = 230A$**   
 **$V_{RRM} = 800 - 1800 V$**

### Preliminary Data

$V_{RSM}$	$V_{RRM}$	Type
$V_{DSM}$	$V_{DRM}$	
V	V	
900	800	MMO230 -08io7 MLO230 -08io7
1300	1200	MMO230 -12io7 MLO230 -12io7
1500	1400	MMO230 -14io7 MLO230 -14io7
1700	1600	MMO230 -16io7 MLO230 -16io7
1900	1800	MMO230 -18io7 MLO230 -18io7

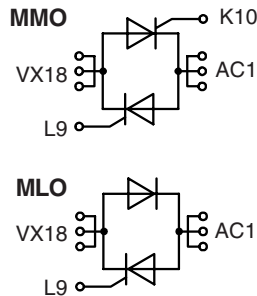

Symbol	Conditions	Maximum Ratings	
$I_{RMS}$	$T_C = 85^\circ C$ ; 50-400 Hz (per single controller)	230	A
$I_{TRMS}$		180	A
$I_{TAVM}$	$T_C = 85^\circ C$ ; 180° sine	105	A
$I_{TSM}$	$T_{VJ} = 45^\circ C$ ; $V_R = 0 V$ ; $t = 10 ms$ (50 Hz), sine $t = 8.3 ms$ (60 Hz), sine	2250	A
		2400	A
$I^2dt$	$T_{VJ} = 45^\circ C$ ; $V_R = 0 V$ ; $t = 10 ms$ (50 Hz), sine $t = 8.3 ms$ (60 Hz), sine	25300	$A^2s$
		23900	$A^2s$
$(di/dt)_{cr}$	$T_{VJ} = 125^\circ C$ ; $f = 50 Hz$ ; $t_p = 200 \mu s$ ; $V_D = \frac{2}{3} V_{DRM}$ ; $I_G = 0.45 A$ ; $di_G/dt = 0.45 A/\mu s$ ;	repetitive, $I_T = 250 A$	150 $A/\mu s$
		non repetitive, $I_T = I_{TAVM}$	500 $A/\mu s$
$(dv/dt)_{cr}$	$T_{VJ} = 125^\circ C$ ; $V_{DR} = \frac{2}{3} V_{DRM}$ $R_{GK} = \infty$ , method 1 (linear voltage rise)	1000	$V/\mu s$
$P_{GM}$	$T_{VJ} = 125^\circ C$ ; $I_T = I_{TAVM}$ ;	$t_p = 30 ms$	$\leq 10$ W
		$t_p = 300 ms$	$\leq 5$ W
$P_{GAVM}$		0.5	W
$V_{RGM}$		10	V
$T_{VJ}$		-40 ... + 125	$^\circ C$
$T_{VJM}$		125	$^\circ C$
$T_{stg}$		-40 ... + 125	$^\circ C$
$V_{ISOL}$	50/60 Hz, RMS $I_{ISOL} \leq 1 mA$	$t = 1 min$	3000 V ~
		$t = 1 s$	3600 V ~
$M_d$	Mounting torque (M4)	1.5 - 2.0	Nm
		14 - 18	lb.in.
Weight	typ.	26	g

### Features

- Thyristor controller for AC (circuit W1C acc. to IEC) for mains frequency
- Isolation voltage 3000 V~
- Planar glass passivated chips
- Low forward voltage drop
- Leads suitable for PC board soldering

### Applications

- Switching and control of single and three phase AC circuits
- Light and temperature control
- Softstart AC motor controller
- Solid state switches

### Advantages

- Easy to mount with two screws
- Space and weight savings
- Improved temperature and power cycling
- High power density
- Small and light weight

Data according to IEC 60747 refer to a single thyristor unless otherwise stated

IXYS reserves the right to change limits, test conditions and dimensions.

Component		Characteristic Values		
Symbol	Conditions	min.	typ.	max.
		$I_D, I_R$	$T_{VJ} = 125^\circ\text{C}; V_R = V_{RRM}; V_D = V_{DRM}$	
$V_T$	$I_T = 300 \text{ A}; T_{VJ} = 25^\circ\text{C}$			1.5 V
$V_{TO}$	For power-loss calculations only			0.8 V
$r_T$				2.4 mΩ
$V_{GT}$	$V_D = 6 \text{ V}; T_{VJ} = 25^\circ\text{C}$ $T_{VJ} = -40^\circ\text{C}$			1.5 V 1.6 V
$I_{GT}$	$V_D = 6 \text{ V}; T_{VJ} = 25^\circ\text{C}$ $T_{VJ} = -40^\circ\text{C}$			150 mA 200 mA
$V_{GD}$	$T_{VJ} = 125^\circ\text{C}; V_D = \frac{2}{3}V_{DRM}$			0.2 V
$I_{GD}$	$T_{VJ} = 125^\circ\text{C}; V_D = \frac{2}{3}V_{DRM}$			10 mA
$I_L$	$T_{VJ} = 25^\circ\text{C}; t_p = 10 \text{ ms}$ $I_G = 0.45 \text{ A}; di_G/dt = 0.45 \text{ A}/\mu\text{s}$			450 mA
$I_H$	$T_{VJ} = 25^\circ\text{C}; V_D = 6 \text{ V}; R_{GK} = \infty$			200 mA
$t_{gd}$	$T_{VJ} = 25^\circ\text{C}; V_D = \frac{1}{2}V_{DRM}$ $I_G = 0.45 \text{ A}; di_G/dt = 0.45 \text{ A}/\mu\text{s}$			2 μs
$R_{thJC}$	per Thyristor; DC per module			0.26 KW 0.13 KW
$R_{thCH}$	per Thyristor; DC per module	0,2		KW KW
$d_s$	Creeping distance on surface			11.2 mm
$d_A$	Creeping distance in air			5.0 mm
$a$	Max. allowable acceleration			50 m/s <sup>2</sup>

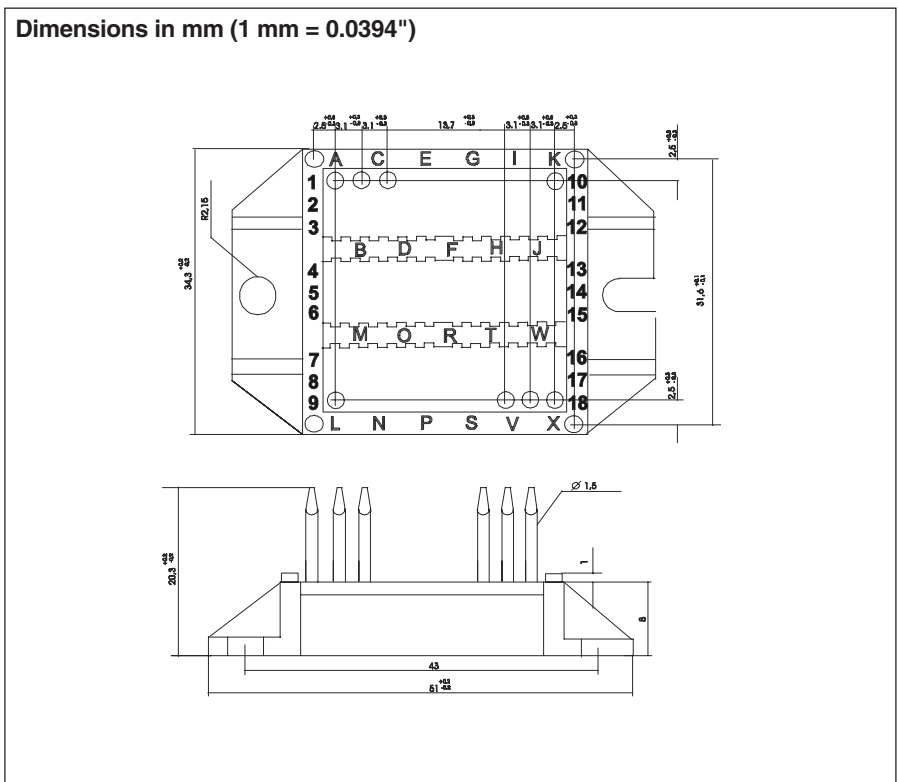

IXYS reserves the right to change limits, test conditions and dimensions.