

# MLX90129

## 13.56MHZ SENSOR TAG / DATALOGGER IC

### Features and Benefits

- Versatile A/D interface for resistive sensors
- ISO-15693 13.56MHz transponder
- Slave / Master SPI interface
- 4 k-bit EEPROM with access protection
- Standalone data-logging mode
- Ultra low power
- Battery or battery-less applications
- Low cost and compact design

### Applications

- Medical and health monitoring sensor tags
- Cold chain monitoring
- Temperature sensor tags
- Asset management and monitoring (security and integrity)
- Industrial, residential control and monitoring

### Ordering information

| Product Code | Temperature Code | Package Code | Option Code | Packing Form Code |
|--------------|------------------|--------------|-------------|-------------------|
| MLX90129     | R                | GO           | CAA-000     | TU                |
| MLX90129     | R                | GO           | CAA-000     | RE                |
| MLX90129     | R                | UC           | CAA-000     | WB                |
| MLX90129     | R                | US           | CAA-000     | WP                |

#### **Legend:**

Temperature Code: R for Temperature Range -40°C to 105°C

Package Code: GO for TSSOP, UC for die on wafer, US for single die

Packing Form: RE for Reel, TU for Tube, WB for waferbox, WP for waffle pack

Ordering example: *MLX90129RGO-CAA-000-TU*

## 1. Functional Diagram

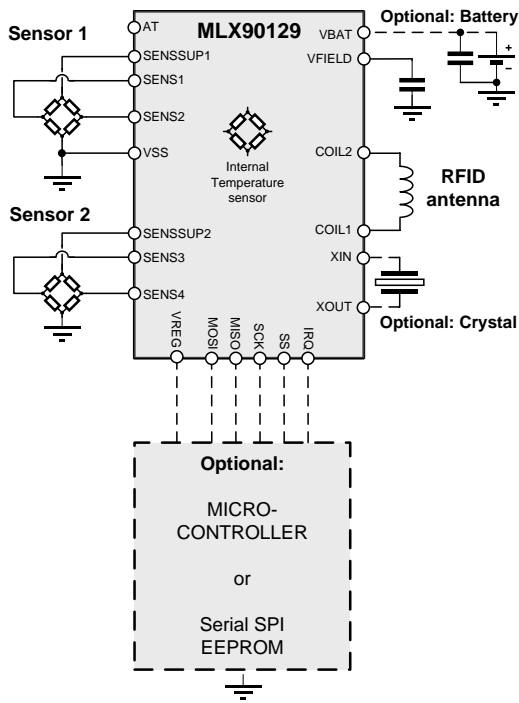

## 2. General Description

The MLX90129 combines a precise analog acquisition chain for external resistive sensors, with a wide range of interface possibilities.

It can be accessed and controlled through its ISO15693 RFID front-end or via its SPI port.

Without any other components than a 13.56MHz tuned antenna, it becomes an RFID temperature sensor.

For measuring other parameters, one or two resistive sensors can be connected to create a battery-less sensing point. The chip also provides a regulated voltage, derived from the RFID field, that can be used to supply the external sensing electronics of the application.

Adding a battery will enable the use of the standalone data logging mode. The sensor output data is stored in the internal 3.5kbits user memory. One can extend the storage capacity by connecting an external EEPROM to the SPI port.

The SPI port can also connect the MLX90129 to a microcontroller which allows more specific applications, like adding actuating capability, LED driving

The MLX90129 has been optimized for low power, low voltage battery and battery-less applications.

### 3. Glossary of Terms

|        |   |
|--------|---|
| EEPROM | Electrically Erasable Programmable Read-Only Memory                 |
| DMA    | Direct Memory Access (It is the digital unit managing data-logging) |
| PGA    | Programmable Gain Amplifier   |
| LFO    | Low Frequency Oscillator  |
| XLFO   | Crystal Low Frequency Oscillator                                    |
| CTC    | Contactless Tuning Capacitance                                      |
| HFO    | High Frequency Oscillator   |

### 4. Absolute Maximum Ratings

| Parameter   | Value           | Unit |
|---|-----------------|------|
| Supply Voltage, $V_{BAT}$ (maximum rating)              | 5.5             | V    |
| Maximum Voltage on any Pin except VFIELD, COIL1 & COIL2 | $V_{BAT} + 0.5$ | V    |
| Reverse Voltage Protection                              | -0.5            | V    |
| Maximum voltage on Pin VFIELD                           | 6               | V    |
| Maximum voltage on Pin COIL1 & COIL2                    | 7               | V    |
| Operating Temperature Range, $T_A$                      | -40 to +105     | °C   |
| Storage Temperature Range, $T_S$                        | 150             | °C   |
| ESD Sensitivity (AEC Q100 002)*                         | 1.5             | kV   |

\* All pin except Pin No 6 (VFIELD limited to 1,5kV) and Pin No 15 (SENSSUP2 limited to 3,5kV)

Exceeding the absolute maximum ratings may cause permanent damage.

Exposure to absolute-maximum-rated conditions for extended periods may affect the device’s reliability.

### 5. Pin definition

|  | Pin |          | I/O | Description                                |
|--|-----|----------|-----|--|
|  | Pin | Symbol   |     |  |
|  | 1   | COIL2    | B   | Coil terminal 2 for RFID interface         |
|  | 2   | COIL1    | B   | Coil terminal 1 for RFID interface         |
|  | 3   | VFIELD   | O   | Unregulated supply voltage (from RF field) |
|  | 4   | VREG     | O   | Regulated supply voltage                   |
|  | 5   | XIN      | I   | Crystal oscillator input 1                 |
|  | 6   | XOUT     | I   | Crystal oscillator input 2                 |
|  | 7   | AT       | I   | Anti Theft (to be connected to ground)     |
|  | 8   | IRQ      | O   | Interrupt output                           |
|  | 9   | MISO     | B   | SPI Master In Slave Out                    |
|  | 10  | MOSI     | B   | SPI Master Out Slave In                    |
|  | 11  | SCK      | B   | SPI Serial Clock                           |
|  | 12  | SS       | B   | SPI Slave Select                           |
|  | 13  | SENS4    | I   | Sensor 2 input 2                           |
|  | 14  | SENS3    | I   |  |
|  | 15  | SENSSUP2 | O   | Sensor 2 supply                            |
|  | 16  | SENSSUP1 | O   | Sensor 1 supply                            |
|  | 17  | SENS2    | I   | Sensor 1 input 2                           |
|  | 18  | SENS1    | I   | Sensor 1 input 1                           |
|  | 19  | VSS      | I   | Ground                                     |
|  | 20  | VBAT     | I   | Battery supply                             |

## Contents

|  |    |
|--|----|
| Features and Benefits.....   | 1  |
| Applications.....  | 1  |
| Ordering information.....  | 1  |
| 1. Functional Diagram.....   | 2  |
| 2. General Description.....  | 2  |
| 3. Glossary of Terms.....  | 3  |
| 4. Absolute Maximum Ratings.....                                     | 3  |
| 5. Pin definition.....   | 3  |
| 6. General Electrical and Timing Specifications.....                 | 6  |
| 6.1. Power consumption.....  | 6  |
| 6.2. RFID interface.....   | 6  |
| 6.3. SPI: electrical specification.....                              | 6  |
| 6.4. Non-volatile memories.....                                      | 7  |
| 6.5. Slave SPI: timing specification.....                            | 7  |
| 6.6. Master SPI timing specifications.....                           | 8  |
| 6.7. Sensor Signal Conditioner: electrical specifications.....       | 9  |
| 6.8. VREG regulator, and Oscillators: electrical specifications..... | 11 |
| 7. General Description.....  | 12 |
| 7.1. Block diagram.....  | 12 |
| 7.2. Digital Controller and memory domains.....                      | 13 |
| 7.2.1. Digital controller.....                                       | 13 |
| 7.2.2. Address domains.....  | 13 |
| 7.3. Internal Devices.....   | 15 |
| 7.3.1. EE-Latches.....   | 16 |
| 7.3.2. Sensors ADC buffers.....                                      | 17 |
| 7.4. Configuration EEPROM & Register files.....                      | 17 |
| 7.4.1. EEPROM Map.....   | 17 |
| 7.4.2. Update of the Register File.....                              | 18 |
| 7.5. EE-Latches and EEPROM Melexis default configuration.....        | 19 |
| 8. Communication.....  | 20 |
| 8.1. RFID communication.....   | 20 |
| 8.1.1. RFID analog front-end.....                                    | 20 |

- 8.1.2. ISO-15693 Features and Command set ..... 20
- 8.1.3. RFID interruptions ..... 29
- 8.2. Serial Peripheral Interface (SPI) ..... 32
  - 8.2.1. SPI : modes of operation..... 32
  - 8.2.2. Slave SPI command set ..... 32
  - 8.2.3. SPI interruptions..... 32
- 8.3. Management of communication conflicts..... 36
- 9. Device Configuration ..... 37**
  - 9.1. Standalone datalogger ..... 37
    - 9.1.1. Main features ..... 37
    - 9.1.2. DMA operations ..... 37
    - 9.1.3. Setup of the Automatic Logging Mode ..... 39
    - 9.1.4. Direct Memory Access configuration..... 40
    - 9.1.5. Wake-up timer / Power management configuration..... 41
    - 9.1.6. Master SPI configuration ..... 42
  - 9.2. Sensor Signal Conditioner ..... 43
    - 9.2.1. Block description..... 43
    - 9.2.2. Sensors common configuration ..... 46
    - 9.2.3. Sensor specific configuration ..... 48
  - 9.3. Power management..... 52
    - 9.3.1. Power modes..... 52
    - 9.3.2. Oscillators management ..... 53
    - 9.3.3. Energy scavenging..... 53
  - 9.4. Security ..... 54
    - 9.4.1. Communication security..... 54
    - 9.4.2. EEPROM Access security..... 54
- 10. Application Information ..... 56**
- 11. Reliability Information ..... 58**
- 12. ESD Precautions..... 58**
- 13. Package Information..... 59**
- 14. Contact ..... 60**
- 15. Disclaimer ..... 60**

## 6. General Electrical and Timing Specifications

DC Operating Parameters  $T_A = -40^{\circ}\text{C}$  to  $105^{\circ}\text{C}$ ,  $V_{\text{BAT}}=4\text{V}$  (unless otherwise specified)

### 6.1. Power consumption

DC Operating Conditions ( $T = -40^{\circ}\text{C}$  to  $105^{\circ}\text{C}$ ,  $V_{\text{REG}} = 2.0\text{V}$  to  $3.2\text{V}$ )

| Parameter  | Conditions   | Min | Typ        | Max          | Unit                           |
|--|--|-----|------------|--------------|--------------------------------|
| Current consumption in "Stand-by" mode                               |  | -   | 0.5*       | 14**         | $\mu\text{A}$                  |
| Current consumption in "Sleep" mode                                  | Using the RC-oscillator<br>Using external oscillator | -   | 1.5*<br>2* | 15**<br>16** | $\mu\text{A}$                  |
| Current consumption in "Watchful" mode                               |  | -   | 100*       | 160**        | $\mu\text{A}$                  |
| Current consumption in "Run" mode (with internal temperature sensor) | Sense & Convert                                      | 300 | 700        | 800**        | $\mu\text{A}$<br>$\mu\text{A}$ |

\* at  $25^{\circ}\text{C}$

\*\* at  $105^{\circ}\text{C}$

### 6.2. RFID interface

DC Operating Conditions ( $T = -40^{\circ}\text{C}$  to  $105^{\circ}\text{C}$ )

| Parameter                               | Conditions                           | Min | Typ | Max | Unit            |
|---|--------------------------------------|-----|-----|-----|-----------------|
| Internal resonance capacitance          | Once trimmed                         | 72  | 75  | 77  | $\text{pF}$     |
| Minimum coil AC voltage (for operation) |                                      |     | 3   |     | $V_{\text{pp}}$ |
| Maximum voltage on Coil1, Coil2         | Induce voltage on VFIELD is below 6V |     |     | 7   | $V_{\text{pp}}$ |
| ISO/IEC 15693-3 data rate               |                                      |     | 26  |     | Kbits/s         |
| Vfield external Capacitor               |                                      |     | 100 |     | nF              |

### 6.3. SPI: electrical specification

DC Operating Conditions ( $T = -40^{\circ}\text{C}$  to  $105^{\circ}\text{C}$ ) and Low-volt option not activated

| Parameter | Description  | Min  | Typ | Max | unit |
|-----------|--|------|-----|-----|------|
| VIH       | Input High Voltage (SPI slave)                           | 2.5  | 3.0 | 3.5 | V    |
| VIL       | Input Low Voltage (SPI slave)                            | -0.5 | 0   | 0.5 | V    |
| VOH       | Output High Voltage ( $I_{\text{sink}} = -1\text{ mA}$ ) | 2.5  |     | -   | V    |
| VOL       | Output Low Voltage ( $I_{\text{forced}} = 1\text{ mA}$ ) | -    |     | 0.4 | V    |

DC Operating Conditions (T = -40°C to 105°C) and Low-volt option activated

| Parameter | Description                          | Min  | Typ | Max | unit |
|-----------|--------------------------------------|------|-----|-----|------|
| VIH       | Input High Voltage (SPI slave)       | 1.4  | 2.0 | 2.5 | V    |
| VIL       | Input Low Voltage (SPI slave)        | -0.3 | 0   | 0.6 | V    |
| VOH       | Output High Voltage (I sunk = -1 mA) | 1.2  |     | -   | V    |
| VOL       | Output Low Voltage (I forced = 1 mA) | -    |     | 0.4 | V    |

### 6.4. Non-volatile memories

| Parameter  | Description                       | Min    | Typ | Max | unit |
|------------|-----------------------------------|--------|-----|-----|------|
| DataRet85  | Data retention at 85°C            | 10     |     |     | year |
| Cyclenb25  | Number of program cycles at 25°C  | 100000 |     |     | -    |
| Cyclenb125 | Number of program cycles at 125°C | 10000  |     |     | -    |

### 6.5. Slave SPI: timing specification

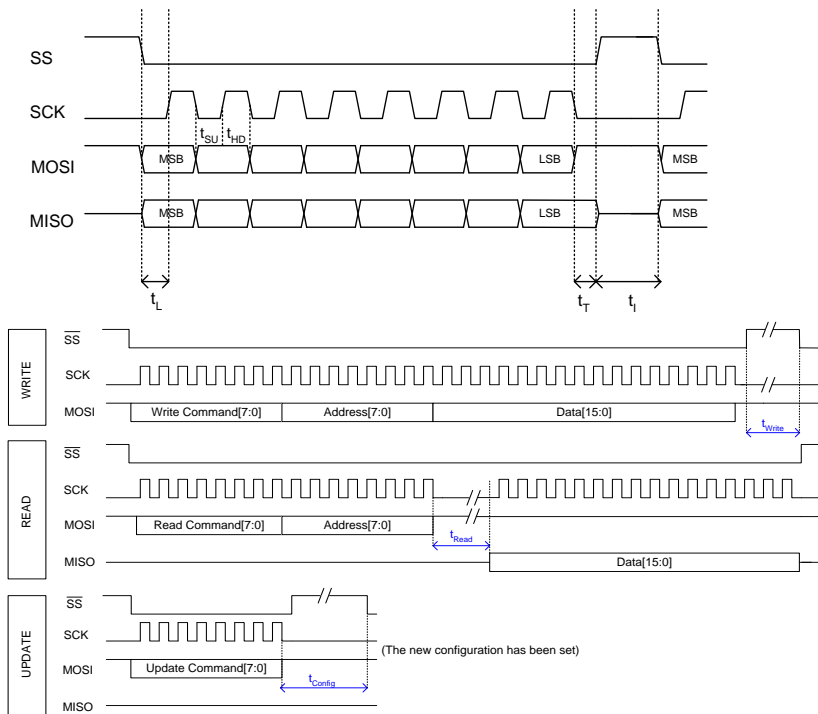

## Timing specifications

| Parameter                      | Description   | Slave side               |                     | Units          |
|--------------------------------|---|--------------------------|---------------------|----------------|
|                                |   | Min                      | Max                 |                |
| t <sub>ch</sub>                | SCK high time   | 500                      | -                   | ns             |
| t <sub>cl</sub>                | SCK low time  | 500                      | -                   | ns             |
| t <sub>Read</sub><br>(*<br>*)  | Delay to read a register word<br>Delay to read an EEPROM word<br>Delay to read an EE-Latch word<br>Delay to get the ADC output code | 2.3<br>80<br>2.3<br>2300 | -<br>-<br>-<br>(* ) | μs             |
| t <sub>Write</sub><br>(*<br>*) | Delay to write a register word<br>Delay to write an EEPROM word<br>Delay to write an EE-Latch word                                  | 2.2<br>18<br>11          | -<br>-<br>-         | us<br>ms<br>ms |
| t <sub>Conf</sub><br>g         | Execution delay for commands <i>Update</i>  | 2.2                      | -                   | ms             |
| t <sub>SU</sub>                | Setup time of data, after a falling edge of SCK   | 100                      | -                   | ns             |
| t <sub>HD</sub>                | Hold time of data, after a rising edge of SCK   | 500                      | -                   | ns             |
| t <sub>L</sub>                 | Leading time before the first SCK edge<br>_ when the MLX90129 is not in sleep mode<br>_ when the MLX90129 is in sleep mode (***)    | 600<br>1.5               | -<br>-              | ns<br>ms       |
| t <sub>T</sub>                 | Trailing time after the last SCK edge   | 500                      | -                   | ns             |
| t <sub>i</sub>                 | Idling time between transfers (SS=1 time)   | 500                      | -                   | ns             |

(\*) – The conversion time depends on the programmed initialization time and on the ADC options.

(\*\*) For the Read/Write Internal Devices commands, the delay depends on the nature of the so-called Internal Device: (Register, EE-Latch bank, ADC,...)

(\*\*\*) – See the power management chapter to know when the MLX90129 may be in sleep mode

## 6.6. Master SPI timing specifications

| Parameter       | Description                                     | Master side |      |     | Units |
|-----------------|---|-------------|------|-----|-------|
|                 |   | Min         | Nom  | Max |       |
| t <sub>ch</sub> | SCK high time                                   |             | 400  |     | ns    |
| t <sub>cl</sub> | SCK low time                                    |             | 400  |     | ns    |
| t <sub>SU</sub> | Setup time of data, after a falling edge of SCK |             | 400  |     | ns    |
| t <sub>HD</sub> | Hold time of data, after a rising edge of SCK   |             | 400  |     | ns    |
| t <sub>L</sub>  | Leading time before the first SCK edge          |             | 400  |     | μs    |
| t <sub>T</sub>  | Trailing time after the last SCK edge           |             | 1    |     | μs    |
| t <sub>i</sub>  | Idling time between transfers (SS=1 time)       |             | 1600 |     | ns    |



## 6.7. Sensor Signal Conditioner: electrical specifications

-40°C < Temp < 105°C, unless otherwise specified. The sensor is supplied by a regulated voltage called  $V_{ref}$ .

| Parameter  | Symbol               | Conditions / Comment  | Min             | Typ             | Max             | Units    |
|--|----------------------|---|-----------------|-----------------|-----------------|----------|
| <b>GENERAL CHARACTERISTICS</b>                       |                      |   |                 |                 |                 |          |
| Battery voltage                                      | Vbat                 | Low-volt option deactivated   | 3.8             |                 | 5.5             | V        |
|  |                      | Low-volt option activated   | 2.7             |                 | 5.5             | V        |
| <b>SENSOR ADJUSTMENT CAPABILITY</b>                  |                      |   |                 |                 |                 |          |
| Sensor Reference voltage<br>$V_{ref}$ <sup>(2)</sup> | SENSSUP1<br>SENSSUP2 | Low-volt option = 0   | 3.0             | 3.1             | 3.2             | V        |
|  |                      | Low-volt option = 1   | 2.0             | 2.1             | 2.2             | V        |
| Full Span<br><sup>(3)</sup>                          | Sens_FS              | Full scale of the sensor output voltage (Sens_CM is at the specified value) | $V_{ref}/1200$  | -               | $V_{ref}/16$    | V        |
| Zero offset <sup>(1)(3)</sup>                        | Sens_Off             | Maximum sensor offset that can be compensated                               | $-V_{ref}/32$   | -               | $+V_{ref}/32$   | V        |
| Common-mode voltage                                  | Sens_CM              |   | $1/3 * V_{ref}$ | $1/2 * V_{ref}$ | $2/3 * V_{ref}$ | V        |
| SENSSUP1 output impedance                            | Sens1_Z              |   |                 | 7               |                 | $\Omega$ |
| SENSSUP2 output impedance                            | Sens2_Z              |   |                 | 15              |                 | $\Omega$ |

Notes:

<sup>(1)</sup>: The capability of adjustment of the input offset depends on the selected gain of the first Programmable Gain Amplifier (PGA1) and on the sensor output span.

<sup>(2)</sup>: The reference voltages of the ADC, of the DAC and the supply voltage of the sensors are ratio-metric.

<sup>(3)</sup>: Full span is defined as the maximal sensor differential output voltage:  $\Delta V(\text{sensor output})_{max}$ , i.e the maximum voltage range allowed on the MLX90129 sensor interface inputs SENS1, SENS2, SENS3 and SENS4.

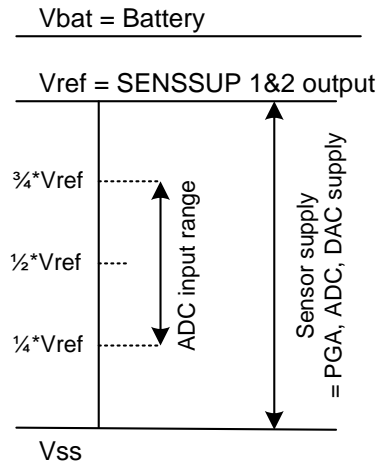

| Parameter                               | Conditions / Comment   | Min           | Typ                         | Max           | Units |
|---|--|---------------|-----------------------------|---------------|-------|
| <b>PROGRAMMABLE-GAIN AMPLIFIER PGA1</b> |  |               |                             |               |       |
| Gain accuracy                           | Code PGA1gain[3:0] =<br>0000 (gain=8) -> 1010 (gain=75)                          | 95            | 100                         | 105           | %typ  |
| <b>PROGRAMMABLE-GAIN AMPLIFIER PGA2</b> |  |               |                             |               |       |
| Gain accuracy                           | Code PGA2gain[2:0] =<br>000 (gain=1) -> 111 (gain=8)                             | 95            | 100                         | 105           | %typ  |
| <b>PGA1 + PGA2 + DAC</b>                |  |               |                             |               |       |
| Gain range                              |  | 8             |                             | 600           | V/V   |
| Sensor offset trimming range            | (= offset max of the sensor)   | $-V_{ref}/32$ |                             | $+V_{ref}/32$ | V     |
| Sensor offset trimming step             | 8-bits DAC (7 bits + sign)<br>Ratio-metric, to cancel the offset of the sensor   |               | $V_{ref}/128$               |               | V     |
| Differential input range                | Gain (PGA) = 8<br>(if higher, PGA_Dir should be $V_{ref}/2$ divided by the gain) |               | $V_{ref}/16$                |               | V     |
| ADC differential input range            |  |               | $\frac{1}{2} \cdot V_{ref}$ |               | V     |
| DAC (differential outputs)              |  |               |                             |               |       |
| Resolution                              | 7 bits + 1 bit sign  |               | 8                           |               | bit   |
| INL                                     |  | 0             |                             | 0.5           | lsb   |
| DNL                                     |  | 0             |                             | 0.5           | lsb   |

| Parameter                               | Conditions / Comment                            | Min | Typ         | Max  | Units                  |
|---|---|-----|-------------|------|------------------------|
| <b>BRIDGE SUPPLIES &amp; REFERENCES</b> |   |     |             |      |                        |
| Reference serial resistance (Rv1, Rv2)  | 6 bits-programmable:<br>Min<br>Max              |     | 0.5<br>63.5 |      | k $\Omega$             |
| Serial resistance accuracy              | Above code 0b000111 (7.5 k $\Omega$ )           | 80  | 100         | 120  | %typ                   |
| Serial resistance step                  |   |     | 1           |      | k $\Omega$             |
| Matching between Rv1 and Rv2            | Above code 0b000111 (7.5 k $\Omega$ )           |     |             | 1    | %                      |
| <b>INTERNAL TEMPERATURE SENSOR</b>      |   |     |             |      |                        |
| Full scale                              |   | -40 |             | +105 | $^{\circ}\text{C}$     |
| Output range                            | $\Delta\text{Temp} = 145^{\circ}\text{C}$ ,     | -   | 155         | -    | mV                     |
| Offset                                  | $\Delta\text{Vout}$ at $T = 25^{\circ}\text{C}$ |     | 45          |      | mV                     |
| Sensitivity                             | $\Delta\text{Vout} / \Delta\text{Temp}$         | -   | 1.06        | -    | mV/ $^{\circ}\text{C}$ |
| Non-linearity (*)                       | $\Delta\text{Temp} = 145^{\circ}\text{C}$       | -   | $\pm 2.65$  | -    | mV                     |

(\*) The internal temperature sensor requires a calibration. On the full range the calibration allows an accuracy of  $\pm 2.5^{\circ}\text{C}$ . This can be improved within a reduced temperature range (e.g.  $\pm 1^{\circ}\text{C}$  within  $-30$  and  $30^{\circ}\text{C}$ ), or by using a remote (external) temperature probe ( $\pm 0.5^{\circ}$  over the full range)

**ADC**

The ADC data output is a 16bit data. The *MODE[1:0]* bits controls the tradeoff between the duration of the counting phase and the resolution. Mode 00 is the fastest but also the least accurate mode whereas the mode 11 is the most accurate but the slowest. The *LOW\_POWER* bit allows the user to reduce the power consumption of the ADC

| ADC parameter                            | Mode 00 | Mode 01 | Mode 10 | Mode 11 | Units |
|--|---------|---------|---------|---------|-------|
| ENOB: effective number of bits           | 8       | 9       | 10      | 11      | bit   |
| Conversion time (*) in normal power mode | 3.2     | 5.8     | 11.3    | 21      | ms    |
| Conversion time (*) in low power mode    | 6.4     | 11.6    | 22.6    | 42      |       |

(\*): To get the sampling rate of the system, the initialization time must be added to the conversion time. This time is programmable as it depends on the selected sensor (by default it is 150  $\mu$ s).

## 6.8. VREG regulator, and Oscillators: electrical specifications

-40°C < Temp < 105°C, unless otherwise specified.

| Parameter                                       | Conditions / Comment                     | Min | Typ | Max       | Units   |
|---|--|-----|-----|-----------|---------|
| <b>VREG REGULATOR</b>                           |  |     |     |           |         |
| VREG Output voltage                             | Low-volt option = 0                      | 2.8 | 3.0 | 3.2       | V       |
|   | Low-volt option = 1 / Vbat >= 3V         | 2.0 | 2.2 | 2.4       | V       |
|   | Low-volt option = 1 / Vbat < 3V          | 2.0 | 2.2 | 2.7       | V       |
| VREG Output max. current                        | Low-volt option = 0                      |     |     | 2.0       | mA      |
|   | Drop 7% VREG                             |     |     | 5.0       | mA      |
|   | Drop 25% VREG                            |     |     | 2.0       | mA      |
|   | Low-volt option = 1                      |     |     | 5.0       | mA      |
| VREG External capacitor                         | Stable smoothed signal                   | 0   | -   | 10        | $\mu$ F |
|   |  |     |     |           |         |
| <b>OSCILLATORS (time base for datalogging )</b> |  |     |     |           |         |
| Accuracy with Internal Low Frequency Oscillator |  |     |     | $\pm$ 15  | %       |
| Accuracy with External Crystal Oscillator       | With an ideal external 32,768kHz crystal |     |     | $\pm$ 0.5 | %       |

## 7. General Description

### 7.1. Block diagram

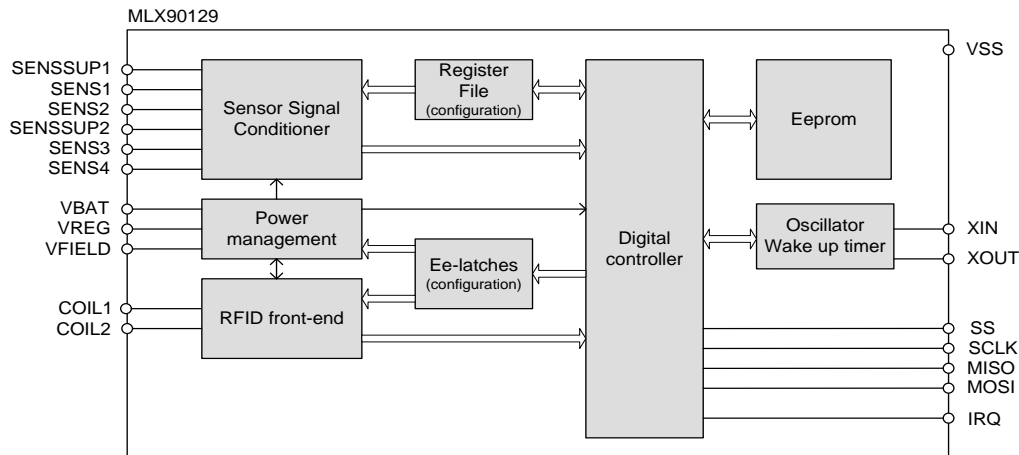

The **sensor signal conditioner** is used to amplify, filter and convert the output voltage of resistive sensors. There may be an external single-ended or differential resistive sensor, or the internal temperature sensor. The two external sensors are supplied by a stable reference voltage, provided by an integrated voltage regulator. The sensor output voltage is amplified by a programmable-gain amplifier, and its offset voltage can be compensated. This way the sensor signal level can be conditioned such that it optimally fits to the input range of the A/D converter. The ADC converts the analog signal into a 16-bit digital code that can be stored or transmitted.

The **power management** unit deals with the different power modes of the chip: it monitors the battery level, scavenges the energy coming from a RFID 13,56MHz field and makes the power-on reset signal. A regulator is used to supply the digital parts, but can also be used to supply some other external devices.

The **Oscillators' block** contains different kinds of oscillators: a very low power, low frequency 1kHz RC oscillator used as a wake-up timer, a low-power 32.768kHz quartz oscillator that can be used for an accurate time basis, and a high frequency 5MHz RC oscillator used for the digital controller.

The **Register File** contains all the configuration parameters of the chip. It may be loaded from the EEPROM after power-on, or as the result of a specific request from RFID or SPI.

The **EE-Latches** are used when device configuration parameters have to be immediately available.

The **RFID front-end** receives an external 13,56-MHz magnetic field, sensed on an external antenna coil. The antenna design is made easy thanks to an internal programmable high-Q capacitance (tuned during the test phase). From the antenna output voltage, it makes a stable clamped DC supply voltage, recovers the clock, and controls the modulation of the carrier and the demodulation of the incoming signal.

The **EEPROM** is a 4-kbit non-volatile memory, organized as 256 words of 16 bits divided in 39 reserved for configuration, 2 for default trimming value (*EE-Latches #03, #04 and #09*) backup and 215 available for the application (around 3.4 kbits user memory). Its access is protected by several security levels.

The **Digital Controller** manages the accesses of the different interfaces (SPI, RFID) with the different memories (EEPROM, register file) and the sensor. It comprises the RFID ISO-15693 and SPI protocols, controls the sensor signal conditioner and stores or sends the ADC output code. It can also run some standalone applications, thanks to its unit called *Direct Memory Access (DMA)*.

## 7.2. Digital Controller and memory domains

### 7.2.1. Digital controller

The main features of the digital part of MLX90129, called *Digital Controller* are:

- Slave / Master SPI interface
- RFID interface
- DMA: Direct Memory Access
- Register File controller
- EEPROM controller
- Sensor interface controller
- Clock and Power management
- Core: transactions arbiter and interrupt manager

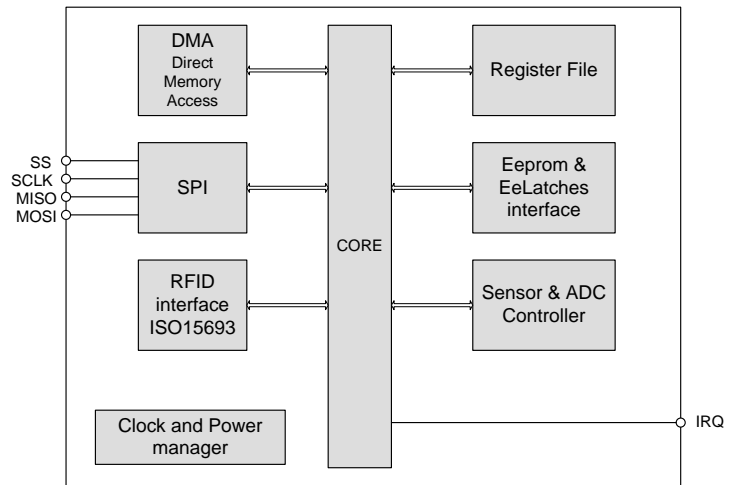

The digital controller manages the transactions between the communication interfaces, the memories and the sensor. It allows also a standalone mode with its DMA unit. All these blocks are described in the next chapters.

The SPI and RFID communication ways can be used concurrently. The *Core transaction arbiter* handles the priorities and the interrupts. It updates some status bits that may be used by the external microcontroller or the RFID base-station to optimize the communication.

The *Digital Controller* of the MLX90129 allows the user to do the following tasks, via SPI or RFID:

- \_ Configure the sensor interface and the communication media.
- \_ Manage the power consumption, the interrupts, the security items,...
- \_ Run A/D conversions of the selected sensors.
- \_ Store (or read) data in the internal or in an external EEPROM.
- \_ Configure and start a standalone process (sleep – sense – interrupt or store – sleep - ...)
- \_ Get the status of the current process.

All these tasks may be done by simply reading or writing the different memories: EEPROM, registers, ee-Latches, internal devices. Thus, several address domains are defined to access them in an easy way.

### 7.2.2. Address domains

Four address domains have been defined to designate the memory and the non-memory devices that act during the requested transactions:

#### - **EEPROM address domain:**

This domain addresses the non-volatile EEPROM. It is used to store the user-defined data and the image of the *Register File* that can be automatically downloaded after a power-on. This memory block is energy independent and can store data even when the MLX90129 is unpowered.

#### - **Register File address domain:**

This memory domain is used to store the current configuration information of all internal MLX90129 devices (Sensor interface, Power management ...). This memory is energy-dependent and must be updated each time the MLX90129 is turned-on.

#### - **Internal Devices address domain:**

This domain allows accessing the registers linked to the so-called *internal devices* like the ADC buffers, the status words of the *Core Transaction Arbiter* and the EE-Latches. They may be accessed with the appropriate SPI / RFID commands including its address. The difference with the Register File is the fact that they are not copied from the EEPROM at the start-up and they may be used during the requested transaction.

**- External memory address domain:**

This domain addresses the external memory which can be connected to the MLX90129, using the SPI in master mode.

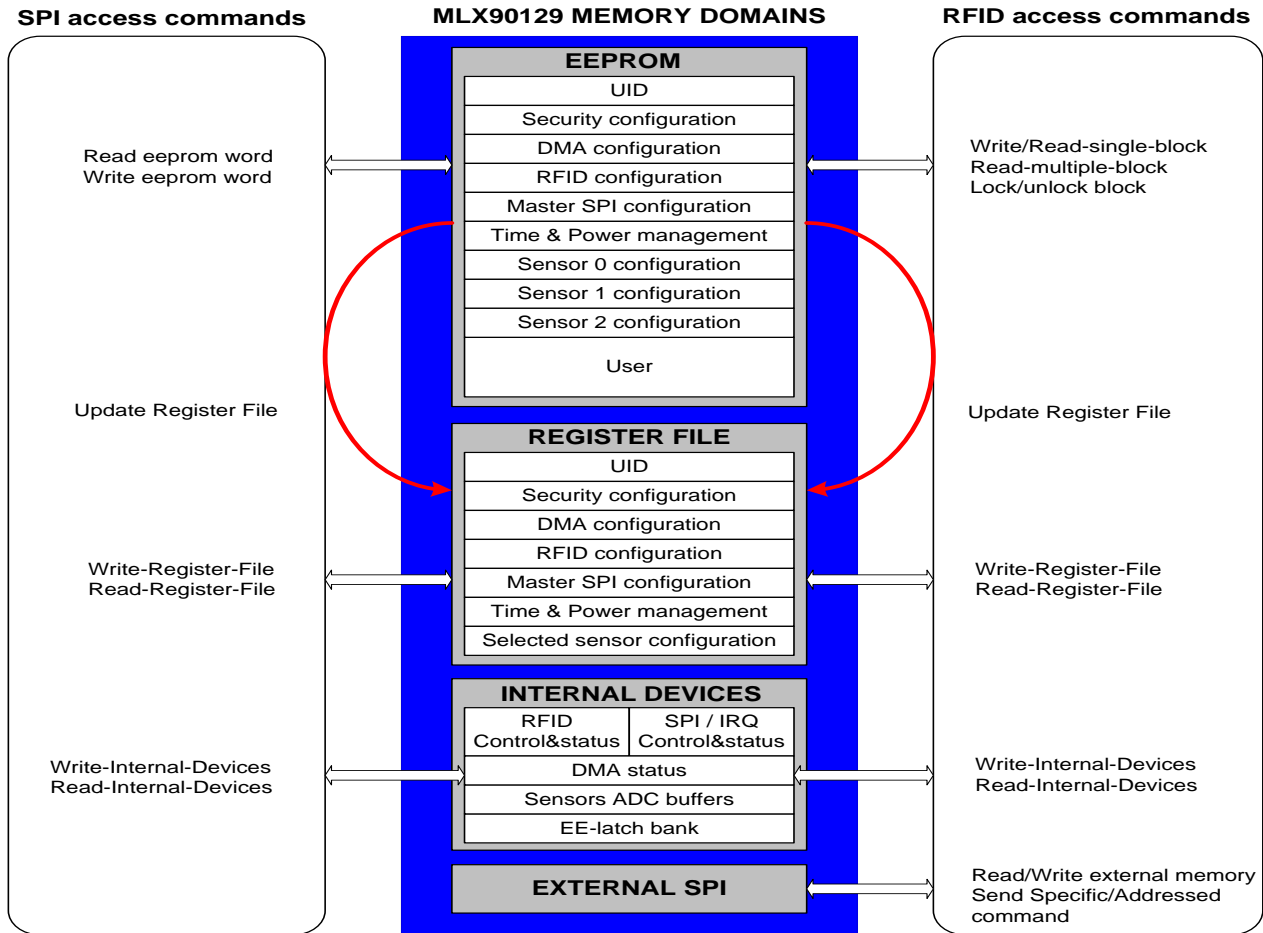

### 7.3. Internal Devices

The term *Internal Devices* designates the registers used to configure the main “non-memory” digital units: sensor interface, SPI / RFID interfaces, DMA ... All these registers are part of the *Internal Device Address Domain*:

The registers linked to the SPI and RFID interfaces, called *SPI/RFID core control word* and *SPI/RFID core interrupt/status word* have the same definition, but are physically different and may contain some different data. The content of these registers are explained in the following chapters (SPI, RFID). Some of these bits may be used to avoid conflicts for the memories access, when communicating with SPI and RFID at the same time. For that, they can be accessed at any time via SPI or RFID.

The SPI / RFID local buffers store the result data of the last transaction. They are useful for example when the A/D conversion time is too long and does not fit the timing requirements of the RFID protocol.

The *EE-Latches* contain some non-volatile data, immediately available (no delay, no supply), used for the options of the clock and power management.

The registers of the DMA unit called *Current destination address* are used to give a status of the process (the number of words that have been registered).

The *ADC buffer* sensor 0, sensor 1 and sensor 2 allow to start a sensor conversion according to the sensor configuration saved in EEPROM in the sensor 0, 1 and 2 configuration are. The conversion starts with the reading of the buffer. The output of the conversion is available in the SPI / RFID local buffer.

#### Map of the *Internal Device Address Domain*

| Addr              | From SPI side                              | From RFID side                              | Link         |
|-------------------|--|---|--------------|
| <b>SPI / RFID</b> |  |   |              |
| 0x00              | SPI core control word                      | RFID core control word                      | Page 32 / 29 |
| 0x01              | SPI core interrupt/status word (read only) | RFID core interrupt/status word (read only) | Page 32 / 29 |
| 0x02              | SPI local buffer (read only)               | RFID local buffer (read only)               | Page 32 / 29 |

| Addr  | Access by SPI and RFID                  |  | Link         |
|---|---|--|--------------|
| <b>Non-volatile memory</b>                  |   |  |              |
| 0x03  | EE-Latches word 0                       |  | Page 16 / 53 |
| 0x04  | EE-Latches word 1                       |  | Page 16 / 52 |
| <b>Direct Memory Access (DMA)</b>           |   |  |              |
| 0x05  | Current destination address (read only) |  | Page 40      |
| <b>Sensors</b>                              |   |  |              |
| 0x06  | ADC buffer sensor 0                     |  | Page 17      |
| 0x07  | ADC buffer sensor 1                     |  | Page 17      |
| 0x08  | ADC buffer sensor 2                     |  | Page 17      |
| <b>Contactless-tuning capacitance (CTC)</b> |   |  |              |
| 0x09  | CTC code                                |  | Page 16      |

Note:  
 The *internal devices* having the addresses 0x00, 0x01, 0x02, 0x05 are registers. Those having the addresses 0x03, 0x04, 0x09 are EE-Latches, and those whose addresses are 0x06, 0x07, and 0x08 refer to the ADC output buffers. The read / write delays are specified for all kind of *internal devices*, when accessing them via SPI.

### 7.3.1. EE-Latches

Another kind of non-volatile memory is used to store the trimming / configuration bits that should be immediately available: the EE-Latch bank. They are mainly used for the trimming of the oscillators and the capacitance of the antenna, for security and power management.

/!\ It is important to read its value before re-programming it, in order to not erase some trimming bits.

**EE-Latches map:** (*Internal Devices Domain, Address #03, #04 and #09, read/write*)

| Bits                           | Name                                 | Description (when the bit is asserted high)  |
|--------------------------------|--------------------------------------|--|
| <b>#03 - EE-Latches word 0</b> |                                      |  |
| 4:0                            | <b>LFO_Freq_Trim</b> (Trimming bits) | (used by Melexis)  |
| 6:5                            | <b>Bias_Cur_Trim</b> (Trimming bits) | (used by Melexis)  |
| 7                              | <b>DisableAutoLoading</b>            | Disables the automatic loading of the Register File with its image from the EEPROM after a power-on reset from the battery |
| 10:8                           | <b>HFO_Freq_Trim</b> (Trimming bits) | (used by Melexis)  |
| 13:11                          | <b>VReg_Trim</b> (Trimming bits)     | (used by Melexis)  |
| 14                             | <b>RCb_Quartz</b>                    | Selects the low-frequency RC-oscillator LFO (=0) or the quartz-oscillator XLFO (=1)  |
| 15                             | <b>Disconnect_Vfield_Vbat</b>        | Disconnects the pads VFIELD and VBAT, when not using the energy from the field to supply the whole device.                 |
| <b>#04 - EE-Latches word 1</b> |                                      |  |
| 1:0                            | <b>Mod_Res</b>                       | 11: default modulator resistance   |
| 2                              | <b>VReg_Dis</b>                      | Disables the VReg regulator and shorts-cut its output to Vbat  |
| 3                              | <b>VReg_LV</b>                       | Low-voltage option for the VREG regulator and the sensor regulator   |
| 7:4                            | Reserved                             | (Must be 0)  |
| 14:8                           | <b>RFID_EEPROM_Lock_Map**</b>        | Map of pages in EEPROM, to be locked for RFID write, using the "Lock" command  |
| 15                             | <b>RFID_Device_Lock**</b>            | Locks the RFID device  |
| <b>#09 - CTC code</b>          |                                      |  |
| 4:0                            | <b>CTC_Trim</b> (Trimming bits)      | (used by Melexis) trimming in the application is also possible   |
| 15:5                           | Not used                             | (Must be 0)  |

(\*\*) - following fields are not accessible for write from RFID interface via device write command.

#### EE-Latches backup in EEPROM

The content of EE-Latches (Internal devices #03, #04 and #09) are copied in the EEPROM for backup:

#### EEPROM #27 and #28

| Bits                                       | Description                             |
|--|---|
| <b>#27 - Internal device backup word 1</b> |   |
| 15:0                                       | Copy of internal device #03 bits [15:0] |
| <b>#28 - Internal device backup word 2</b> |   |
| 3:0  | Copy of internal device #04 bits [3:0]  |
| 15:4                                       | random                                  |

Ex: The command read ADC buffer sensor 0 (Read Internal Device #06) sent by RFID or by SPI loads the configuration of the sensor 0 from EEPROM (address #15 to #1A) into the register file and start the A/D conversion. The output of the conversion is available in the *internal device #02* (local buffer).



### 7.3.2. Sensors ADC buffers

In order to read the output data of a sensor, the SPI master or the RFID base-station has to access one of the 3 *ADC buffer* in the *Internal Device address domain*. Accessing (read command) this buffer makes:

- Load the selected sensor configuration into the register file
- Start the A/D conversion and the data processing.

Then the command read ADC buffer sensor 2 (Read Internal Device #08) sent by RFID or by SPI overwrite the register file with the configuration of the sensor 2 (EEPROM from #21 to #26).

To make sure that all operations are done, it is enough to:

- Wait for a specific period of time and read the *internal device #02* (local buffer).
- Periodically monitor the *SPI/RFID Core status word* and check the bit: *Sensor interrupt: Data ready*.

## 7.4. Configuration EEPROM & Register files

The MLX90129 embeds a 4kbits EEPROM memory. This non-volatile memory contains the configuration parameters and some identification numbers. The configuration part of the EEPROM consists of 45 words of 16 bits. The 210 other words are available for the specific needs of the application or may be used for data-logging or for the configuration of the external devices. The read and write access rights are defined for each page and depends on the device wanting to access it: a microcontroller, a RFID base-station or the internal DMA unit of the MLX90129. The user can also lock and unlock some pages by sending the appropriate RFID commands.

### 7.4.1. EEPROM Map

| Address  | Description                                      | Link    |
|--|--|---------|
| <b>UID (Unique Identifier)</b>                             |  |         |
| #00  | UID: bits 15:0                                   | Page 20 |
| #01  | UID: bits 31:16                                  | Page 20 |
| #02  | UID: bits 47:32                                  | Page 20 |
| #03  | UID: bits 63:48                                  | Page 20 |
| <b>Security configuration space</b>                        |  |         |
| #04  | EEPROM security map                              | Page 54 |
| #05  | Device security map                              | Page 54 |
| #06  | Password RFID                                    | Page 54 |
| #07  | (not used)                                       |         |
| #08  | (not used)                                       |         |
| <b>DMA configuration space</b>                             |  |         |
| #09  | DMA: Control word                                | Page 40 |
| #0A  | DMA: Source address word                         | Page 40 |
| #0B  | DMA: Destination address word                    | Page 40 |
| #0C  | DMA: Length                                      | Page 40 |
| <b>SPI (External memory) configuration space</b>           |  |         |
| #0D  | External memory: Control word                    | Page 42 |
| #0E  | External memory: Command codes word              | Page 42 |
| <b>Timer (power control) configuration space</b>           |  |         |
| #0F  | Timer: Period                                    | Page 41 |
| #10  | Timer: control word                              | Page 41 |
| <b>Address space always accessible from RFID interface</b> |  |         |
| #11  | RFID user register: its purpose is user-defined. | Page 20 |

| Address                                   | Description  |         |
|---|--|---------|
| <b>Sensors common configuration space</b> |  |         |
| #12                                       | Sensor power configuration word                                | Page 46 |
| #13                                       | (reserved)   |         |
| #14                                       | Sensor trimming configuration word                             | Page 46 |
| <b>Sensor 0 configuration space</b>       |  |         |
| #15                                       | <i>Sensor 0</i> : Sensor control word                          | Page 48 |
| #16                                       | <i>Sensor 0</i> : Sensor low threshold word                    | Page 48 |
| #17                                       | <i>Sensor 0</i> : Sensor high threshold word                   | Page 48 |
| #18                                       | <i>Sensor 0</i> : Sensor signal conditioner configuration word | Page 48 |
| #19                                       | <i>Sensor 0</i> : Sensor connections configuration word        | Page 48 |
| #1A                                       | <i>Sensor 0</i> : Sensor resistance configuration word         | Page 48 |
| <b>Sensor 1 configuration space</b>       |  |         |
| #1B                                       | <i>Sensor 1</i> : Sensor control word                          | Page 48 |
| #1C                                       | <i>Sensor 1</i> : Sensor low threshold word                    | Page 48 |
| #1D                                       | <i>Sensor 1</i> : Sensor high threshold word                   | Page 48 |
| #1E                                       | <i>Sensor 1</i> : Sensor signal conditioner configuration word | Page 48 |
| #1F                                       | <i>Sensor 1</i> : Sensor connections configuration word        | Page 48 |
| #20                                       | <i>Sensor 1</i> : Sensor resistance configuration word         | Page 48 |
| <b>Sensor 2 configuration space</b>       |  |         |
| #21                                       | <i>Sensor 2</i> : Sensor control word                          | Page 48 |
| #22                                       | <i>Sensor 2</i> : Sensor low threshold word                    | Page 48 |
| #23                                       | <i>Sensor 2</i> : Sensor high threshold word                   | Page 48 |
| #24                                       | <i>Sensor 2</i> : Sensor signal conditioner configuration word | Page 48 |
| #25                                       | <i>Sensor 2</i> : Sensor connections configuration word        | Page 48 |
| #26                                       | <i>Sensor 2</i> : Sensor resistance configuration word         | Page 48 |
| <b>EE-Latches backup space</b>            |  |         |
| #27                                       | Internal device backup word 1                                  | Page 16 |
| #28                                       | Internal device backup word 2                                  | Page 16 |

(\*\*) In the register file, this configuration space is updated from the appropriate part of the *Extended sensor configuration space* at each access to one of the three sensors. This configuration space and all others with higher addresses are not updated during a *Register File Update* operation.

### 7.4.2. Update of the Register File

The EEPROM contains the initial image of the *Register File*. This image is copied after the power-on, upon a SPI / RFID *Update* request. The sensor configuration in the *Register File* depends on the currently selected sensor. The sensor is selected either manually by reading the ADC buffer corresponding or automatically during a standalone application.

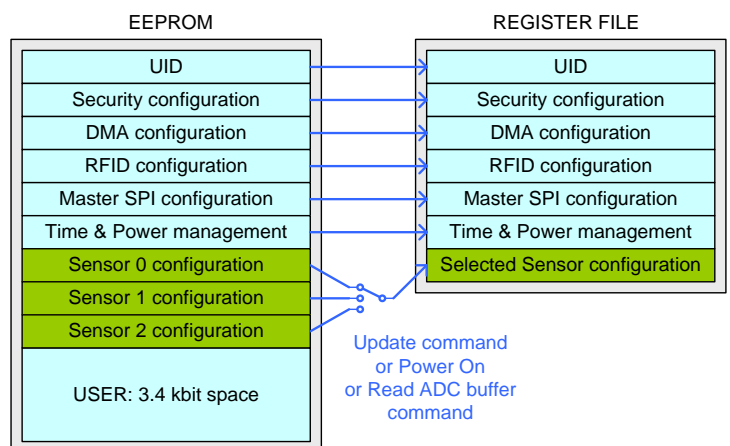

## 7.5. EE-Latches and EEPROM Melexis default configuration

The MLX90129 is pre-set with the following configuration.

| Address           | Default value         | Description  |
|-------------------|-----------------------|--|
| <b>EEPROM</b>     |                       |  |
| [#03 - #00]       | 0xXXXX                | Unique ID set by Melexis                                       |
| #04               | 0xAAA8                | Refer to EEPROM security map                                   |
| #05               | 0x3FF0                | Refer to device security register                              |
| [#0B - #06]       | 0x0000                |  |
| #0C               | 0xXXXX                | Random value, can be replaced by 0x0000                        |
| [#10 - #0D]       | 0x0000                |  |
| #11               | 0xXXXX                | Random value, can be replaced by 0x0000                        |
| #12               | 0x00FF                | Refer to sensor power configuration                            |
| #13               | 0x0000                |  |
| #14               | 0b0000.00TT.TT00.0000 |  |
| [#FF - #15]       | 0xXXXX                | Random value, can be replaced by 0x0000                        |
| <b>EE-Latches</b> |                       |  |
| 03                | 0b00TT.TTTT.0TTT.TTTT | Data loading enabled / LFO selected / Vfield connected to Vbat |
| 04                | 0x000B                | Low volt option =1   |
| 09                | 0b0000.0000.000T.TTTT | Reading gives 0x001F   |

'T' are Melexis trimming bits

In order to configure the registers of the MLX90129 easily, a configuration tool can be downloaded from the Melexis web site, [www.melexis.com](http://www.melexis.com).

|    | A   | B              | C           | D         | E         | F         | G         | H         | I         | J        | K        | L        | M        | N        | O        | P        | Q        | R        | S        | T                    |                       |
|----|---|----------------|-------------|-----------|-----------|-----------|-----------|-----------|-----------|----------|----------|----------|----------|----------|----------|----------|----------|----------|----------|----------------------|-----------------------|
| 1  | <b>MLX90129 CONFIGURATION</b>                               |                |             |           |           |           |           |           |           |          |          |          |          |          |          |          |          |          |          |                      |                       |
| 2  | update: 25/05/2010 rev 1.3                                  |                |             |           |           |           |           |           |           |          |          |          |          |          |          |          |          |          |          |                      |                       |
| 3  | ! The Excel Add-Ins "Analysis ToolPak" need to be activated |                |             |           |           |           |           |           |           |          |          |          |          |          |          |          |          |          |          |                      |                       |
| 4  |   |                |             |           |           |           |           |           |           |          |          |          |          |          |          |          |          |          |          |                      |                       |
| 5  | <b>EEPROM CONFIGURATION</b>                                 |                |             |           |           |           |           |           |           |          |          |          |          |          |          |          |          |          |          |                      |                       |
| 6  | <b>Content</b>  | <b>Address</b> | <b>Hexa</b> | <b>15</b> | <b>14</b> | <b>13</b> | <b>12</b> | <b>11</b> | <b>10</b> | <b>9</b> | <b>8</b> | <b>7</b> | <b>6</b> | <b>5</b> | <b>4</b> | <b>3</b> | <b>2</b> | <b>1</b> | <b>0</b> | <b>Default Value</b> |                       |
| 8  | ID  | 00             | 0000        | 0         | 0         | 0         | 0         | 0         | 0         | 0        | 0        | 0        | 0        | 0        | 0        | 0        | 0        | 0        | 0        | 0                    | UID                   |
| 9  | ID  | 01             | 0000        | 0         | 0         | 0         | 0         | 0         | 0         | 0        | 0        | 0        | 0        | 0        | 0        | 0        | 0        | 0        | 0        | 0                    | UID                   |
| 10 | ID  | 02             | 0000        | 0         | 0         | 0         | 0         | 0         | 0         | 0        | 0        | 0        | 0        | 0        | 0        | 0        | 0        | 0        | 0        | 0                    | UID                   |
| 11 | ID  | 03             | 0000        | 0         | 0         | 0         | 0         | 0         | 0         | 0        | 0        | 0        | 0        | 0        | 0        | 0        | 0        | 0        | 0        | 0                    | UID                   |
| 12 |   |                |             |           |           |           |           |           |           |          |          |          |          |          |          |          |          |          |          |                      |                       |
| 13 | Eeprom security   | 04             | AAA8        | 1         | 0         | 1         | 0         | 1         | 0         | 1        | 0        | 1        | 0        | 1        | 0        | 1        | 0        | 0        | 0        | 0                    | 0xAAA8                |
| 14 | Device security   | 05             | 3FF0        | 0         | 0         | 1         | 1         | 1         | 1         | 1        | 1        | 1        | 1        | 1        | 1        | 1        | 0        | 0        | 0        | 0                    | 0x3FF0                |
| 15 | RFID password   | 06             | 0000        | 0         | 0         | 0         | 0         | 0         | 0         | 0        | 0        | 0        | 0        | 0        | 0        | 0        | 0        | 0        | 0        | 0                    |                       |
| 16 |   |                |             |           |           |           |           |           |           |          |          |          |          |          |          |          |          |          |          |                      |                       |
| 17 | DMA configuration   | 09             | 0005        | 0         | 0         | 0         | 0         | 0         | 0         | 0        | 0        | 0        | 0        | 0        | 0        | 0        | 0        | 1        | 0        | 1                    |                       |
| 18 | DMA source start address                                    | 0A             | 0000        | 0         | 0         | 0         | 0         | 0         | 0         | 0        | 0        | 0        | 0        | 0        | 0        | 0        | 0        | 0        | 0        | 0                    |                       |
| 19 | DMA destination start address                               | 0B             | 0000        | 0         | 0         | 0         | 0         | 0         | 0         | 0        | 0        | 0        | 0        | 0        | 0        | 0        | 0        | 0        | 0        | 0                    |                       |
| 20 | DMA processing length                                       | 0C             | 0000        | 0         | 0         | 0         | 0         | 0         | 0         | 0        | 0        | 0        | 0        | 0        | 0        | 0        | 0        | 0        | 0        | 0                    |                       |
| 21 |   |                |             |           |           |           |           |           |           |          |          |          |          |          |          |          |          |          |          |                      |                       |
| 22 | SPI-master configuration                                    | 0D             | 0000        | 0         | 0         | 0         | 0         | 0         | 0         | 0        | 0        | 0        | 0        | 0        | 0        | 0        | 0        | 0        | 0        | 0                    |                       |
| 23 | SPI-master commands codes                                   | 0E             | 0000        | 0         | 0         | 0         | 0         | 0         | 0         | 0        | 0        | 0        | 0        | 0        | 0        | 0        | 0        | 0        | 0        | 0                    |                       |
| 24 |   |                |             |           |           |           |           |           |           |          |          |          |          |          |          |          |          |          |          |                      |                       |
| 25 | Timer period  | 0F             | 0001        | 0         | 0         | 0         | 0         | 0         | 0         | 0        | 0        | 0        | 0        | 0        | 0        | 0        | 0        | 0        | 0        | 1                    |                       |
| 26 | Timer control   | 10             | 0011        | 0         | 0         | 0         | 0         | 0         | 0         | 0        | 0        | 0        | 0        | 0        | 0        | 1        | 0        | 0        | 0        | 1                    |                       |
| 27 |   |                |             |           |           |           |           |           |           |          |          |          |          |          |          |          |          |          |          |                      |                       |
| 28 | RFID user register  | 11             | 0000        | 0         | 0         | 0         | 0         | 0         | 0         | 0        | 0        | 0        | 0        | 0        | 0        | 0        | 0        | 0        | 0        | 0                    |                       |
| 29 |   |                |             |           |           |           |           |           |           |          |          |          |          |          |          |          |          |          |          |                      |                       |
| 30 | Sensor power configuration                                  | 12             | 40FF        | 0         | 1         | 0         | 0         | 0         | 0         | 0        | 0        | 1        | 1        | 1        | 1        | 1        | 1        | 1        | 1        | 1                    | 0x00FF                |
| 31 | Sensor trimming   | 14             | 3000        | 0         | 0         | 1         | 1         | 0         | 0         | 0        | 0        | 0        | 0        | 0        | 0        | 0        | 0        | 0        | 0        | 0                    | 0b0000.00TT.TT00.0000 |
| 32 |   |                |             |           |           |           |           |           |           |          |          |          |          |          |          |          |          |          |          |                      |                       |
| 33 | Sensor 0 control word                                       | 15             | 0200        | 0         | 0         | 0         | 0         | 0         | 0         | 1        | 0        | 0        | 0        | 0        | 0        | 0        | 0        | 0        | 0        | 0                    |                       |
| 34 | Sensor 0 low threshold                                      | 16             | 0000        | 0         | 0         | 0         | 0         | 0         | 0         | 0        | 0        | 0        | 0        | 0        | 0        | 0        | 0        | 0        | 0        | 0                    |                       |
| 35 | Sensor 0 high threshold                                     | 17             | 0000        | 0         | 0         | 0         | 0         | 0         | 0         | 0        | 0        | 0        | 0        | 0        | 0        | 0        | 0        | 0        | 0        | 0                    |                       |
| 36 | Sensor 0 conditioner config.                                | 18             | 0000        | 0         | 0         | 0         | 0         | 0         | 0         | 0        | 0        | 0        | 0        | 0        | 0        | 0        | 0        | 0        | 0        | 0                    |                       |
| 37 | Sensor 0 connection config.                                 | 19             | 0000        | 0         | 0         | 0         | 0         | 0         | 0         | 0        | 0        | 0        | 0        | 0        | 0        | 0        | 0        | 0        | 0        | 0                    |                       |
| 38 | Sensor 0 resistance network                                 | 1A             | 0020        | 0         | 0         | 0         | 0         | 0         | 0         | 0        | 0        | 0        | 0        | 0        | 1        | 0        | 0        | 0        | 0        | 0                    |                       |
| 39 |   |                |             |           |           |           |           |           |           |          |          |          |          |          |          |          |          |          |          |                      |                       |
| 40 | Sensor 1 control word                                       | 1B             | 0000        | 0         | 0         | 0         | 0         | 0         | 0         | 0        | 0        | 0        | 0        | 0        | 0        | 0        | 0        | 0        | 0        | 0                    |                       |
| 41 | Sensor 1 low threshold                                      | 1C             | 0000        | 0         | 0         | 0         | 0         | 0         | 0         | 0        | 0        | 0        | 0        | 0        | 0        | 0        | 0        | 0        | 0        | 0                    |                       |
| 42 | Sensor 1 high threshold                                     | 1D             | 0000        | 0         | 0         | 0         | 0         | 0         | 0         | 0        | 0        | 0        | 0        | 0        | 0        | 0        | 0        | 0        | 0        | 0                    |                       |

## 8. Communication

### 8.1. RFID communication

#### 8.1.1. RFID analog front-end

The MLX90129 RFID interface complies with the ISO15693 standard. The sensor tag gets accessed through an RFID base-station (reader) by modulating the 13.56MHz carrier frequency. Data recovery is done from the amplitude modulated reader signal (ASK, Amplitude Shift Keying 10% or 100%). The data transfer rate is 26 kbps while using a 1-out-of-4 coding scheme. From the incoming HF field, the RFID interface recovers the clock and generates a power supply for all internal building blocks. The rectified voltage can be used to supply the whole device in battery-less applications.

The data upload (from the tag to the reader) is generated by antenna load modulation with Manchester coding, and using one or two sub-carrier frequencies at 423 kHz and 484 kHz. The data transfer rate is 26 kbps.

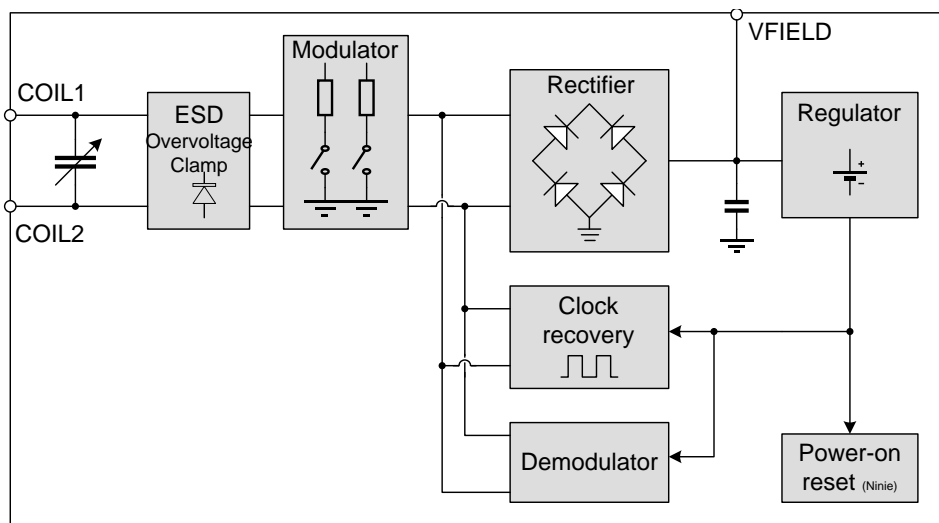

#### 8.1.2. ISO-15693 Features and Command set

For complete information about the communication protocol, please refer to the standard document:

ISO/IEC FCD 15693-2 and ISO/IEC FCD 15693-3: **Identification cards- contactless integrated circuit(s) cards - Vicinity cards** - It is available on the website: <http://www.iso.org>

Some of the features of the protocol are not supported. Furthermore, some “custom” commands have been defined (see Command set). The MLX90129 is provided with a Unique IDentifier compliant with the ISO standard.

#### Summary of the main, supported features

| Features                              | Supported                             | Not supported        |
|---------------------------------------|---------------------------------------|----------------------|
| <b>Reader to Tag Modulation Index</b> | 10% and 100%                          |                      |
| Reader to Tag Coding                  | Pulse Position Modulation: 1 out of 4 | PPM: 1 out of 256    |
| <b>Tag to Reader Modulation</b>       | Single and dual Sub-carrier           |                      |
| <b>Tag to Reader Sub-Carrier</b>      | 423 kHz / 484 kHz                     |                      |
| <b>Tag to Reader Coding</b>           | Manchester                            |                      |
| <b>Tag to Reader Data-rate</b>        | High Data-rate 26 kBit                | Low Data-rate 6 kBit |

**Summary of the main, supported protocol parts**

- Data element

| Data Element                           | Supported |
|--|-----------|
| UID (Unique Identifier)                | Yes       |
| AFI (Application Family Identifier)    | No        |
| DSFID (Data Storage Format Identifier) | No        |
| CRC                                    | Yes       |
| Security status                        | No        |

- Protocol

| Request Flag                              | Supported |
|---|-----------|
| Sub-Carriers                              | Yes       |
| Data-rates                                | No        |
| Inventory                                 | Yes       |
| Protocol extension                        | No        |
| Select                                    | Yes       |
| Address                                   | Yes       |
| Options (write single block command only) | Yes       |
| Response Flag                             | Supported |
| Error                                     | Yes       |

- Anti-collision: Supported

**Command frame**

The content of the data included in the frame of a communication request, and the response from the MLX90129 to the base-station depends on the command opcode. The meaning of the flags, the equation of the CRC, the description of the Start-Of-Frame, the End-Of-Frame and the unique identifier number (UID), the meaning of the error codes... are included in the standard ISO-15693 layers 2 and 3.

Request format for ISO15693 commands:

| SOF | Flags           | Command code | (UID)    | (Data) | CRC 16  | EOF |
|-----|-----------------|--------------|----------|--------|---------|-----|
|     | 8 bits          | 8 bits       | 64 bits  | x bits | 16 bits |     |
|     | 0XXX 0X1X (bin) | XX (hex)     | Optional |        |         |     |

Request format for MLX90129 commands:

| SOF | Flags           | Command code | (UID)    | (Data)   | CRC 16  | EOF |
|-----|-----------------|--------------|----------|----------|---------|-----|
|     | 8 bits          | 16 bits      | 64 bits  | x bits   | 16 bits |     |
|     | 00XX 0X1X (bin) | XX1F (hex)   | Optional | Optional |         |     |

Response format without data when Error\_flag is NOT set:

| SOF | Flags     | CRC 16  | EOF |
|-----|-----------|---------|-----|
|     | 8 bits    | 16 bits |     |
|     | 0000 0000 |         |     |

## MLX90129

13.56MHZ SENSOR TAG / DATALOGGER IC

Response format with data when Error\_flag is NOT set:

| SOF | Flags     | (Data) | CRC 16  | EOF |
|-----|-----------|--------|---------|-----|
|     | 8 bits    | x bits | 16 bits |     |
|     | 0000 0000 |        |         |     |

Response format with error when Error\_flag is set:

| SOF | Flags     | Error code | CRC 16  | EOF |
|-----|-----------|------------|---------|-----|
|     | 8 bits    | 8 bits     | 16 bits |     |
|     | 0000 0001 |            |         |     |

## Command set

The command set lists the mandatory commands defined in the standard ISO-15693 layer 3. It comprises also some custom commands used for some specific applications: access the sensor buffer, access an external device via SPI, handles the security options, etc.

### ISO-15693 mandatory and optional commands

| Commands            | code | Description   |
|---------------------|------|---|
| Inventory           | 01   | Enable an anti-collision sequence   |
| Stay quiet          | 02   | Enable the ' <i>Stay Quiet</i> ' mode                                       |
| Read single block   | 20   | Read a single word from EEPROM  |
| Write single block  | 21   | Write a single word to EEPROM (only mode with Option_flag set is supported) |
| Read multiple block | 23   | Read one or several contiguous blocks of the EEPROM                         |
| Select              | 25   | Enter the "Selected" state (anti-collision)                                 |
| Reset to ready      | 26   | Return to the ' <i>Ready</i> ' mode   |

### MLX90129 custom commands

| Commands                        | code | Description  |
|---------------------------------|------|--|
| Read register file              | A01F | Read one word from the <i>Register file</i>  |
| Write register file             | A11F | Write one word to the <i>Register file</i>   |
| Read internal device            | A21F | Read the content of an <i>internal device</i> identified by an address byte  |
| Write internal device           | A31F | Write the register word of an <i>internal device</i> , identified by an address byte   |
| Read external memory            | A41F | Read a word from an external memory (via SPI)  |
| Write external memory           | A51F | Write a word into an external memory (via SPI)   |
| Send specific command           | A61F | Send a command via SPI to an external device, whose code is appended to the frame (e.g. Write Enable for an external EEPROM).                  |
| Send addressed specific command | A71F | Send a command via SPI to an external device, whose code and address are appended to the frame (e.g. <i>Lock Block</i> for an external EEPROM) |
| Write external memory status    | A81F | Send a command via SPI, to write an external memory status register (The op-code of this command is stored in a register)                      |
| Read external memory status     | A91F | Send a command via SPI, to read an external memory status register (The op-code of this command is stored in a register)                       |
| Lock device                     | B01F | Lock an <i>internal device</i> (EEPROM, ADC, ...), preventing its access.  |
| Unlock device                   | B11F | Unlock an <i>internal device</i>   |
| Update Register File            | C01F | Fill the <i>Register File</i> with the image from the EEPROM, without re-boot  |
| Lock Page                       | D01F | Lock a page of EEPROM  |
| Unlock Page                     | D11F | Unlock a locked page of EEPROM.  |

0x1F corresponds to the RFID manufacturer code of Melexis

**ISO-15693 mandatory and optional commands frame content**

- **INVENTORY (01)**

When receiving the Inventory request, the transponder shall perform the anti-collision sequence. The Inventory flag shall be set to 1.

Request format:

|   |           |                   |             |             |         |   |
|---|-----------|-------------------|-------------|-------------|---------|---|
| S | Flags     | Inventory command | Mask length | Mask value  | CRC 16  | E |
| O | 8 bits    | 8 bits            | 8 bits      | 0 - 64 bits | 16 bits | O |
| F | 00x0 011x | 0000 0001         |             |             |         | F |

Response format (if no error):

|   |           |           |         |         |   |
|---|-----------|-----------|---------|---------|---|
| S | Flags     | DSFID     | UID     | CRC 16  | E |
| O | 8 bits    | 8 bits    | 64 bits | 16 bits | O |
| F | 0000 0000 | 0000 0000 |         |         | F |

- **STAY QUIET (02)**

When receiving the Stay Quiet command, the transponder shall enter the Quiet state and shall not send back a response. This command shall always be executed in Addressed mode (Select flag=0 and Address flag= 1). To exit the Quiet state with a MLX90129 battery powered, the command “Reset to ready” has to be sent by the reader.

Request format:

|   |           |                    |         |         |   |
|---|-----------|--------------------|---------|---------|---|
| S | Flags     | Stay Quiet command | UID     | CRC 16  | E |
| O | 8 bits    | 8 bits             | 64 bits | 16 bits | O |
| F | 001x 001x | 0000 0010          |         |         | F |

- **READ SINGLE BLOCK (20)**

When receiving the Read single block request, the transponder shall read the requested block from internal EEPROM and send back its value in the response.

Request format:

|   |           |                   |            |               |         |   |
|---|-----------|-------------------|------------|---------------|---------|---|
| S | Flags     | Read Single Block | UID        | Block address | CRC 16  | E |
| O | 8 bits    | 8 bits            | 64 bits    | 8 bits        | 16 bits | O |
| F | 00xx 001x | 0010 0000         | (Optional) |               |         | F |

Response format (if no error):

|   |           |         |         |   |
|---|-----------|---------|---------|---|
| S | Flags     | Data    | CRC 16  | E |
| O | 8 bits    | 16 bits | 16 bits | O |
| F | 0000 0000 |         |         | F |

- **WRITE SINGLE BLOCK (21)**

When receiving the “Write Single Block” request, the transponder shall write the requested block into internal EEPROM with the data contained in the request and report the success of the operation in the response. Only the mode with Option\_flag set is supported. That means, the MLX90129 shall wait for the reception of an end of frame (EOF) from the ISO15693 reader and upon such reception shall return its response.

Request format:

|   |           |                   |            |               |         |         |   |
|---|-----------|-------------------|------------|---------------|---------|---------|---|
| S | Flags     | Read Single Block | UID        | Block address | Data    | CRC 16  | E |
| O | 8 bits    | 8 bits            | 64 bits    | 8 bits        | 16 bits | 16 bits | O |
| F | 01xx 001x | 0010 0001         | (Optional) |               |         |         | F |



- **READ MULTIPLE BLOCKS (23)**

When receiving the “Read Multiple Block” command, the transponder shall read the requested block(s) and send back their value in the response. The blocks are numbered from ‘00’ to ‘FF’. The number of blocks in the request is one less than the number of blocks that the 90129 shall return in its response.

Request format:

|   |           |                     |            |                     |                  |         |   |
|---|-----------|---------------------|------------|---------------------|------------------|---------|---|
| S | Flags     | Read Multiple Block | UID        | First block address | Number of blocks | CRC 16  | E |
| O | 8 bits    | 8 bits              | 64 bits    | 8 bits              | 8 bits           | 16 bits | O |
| F | 00xx 001x | 0010 0011           | (Optional) |                     | N                |         | F |

Response format (if no error):

|   |           |               |         |   |
|---|-----------|---------------|---------|---|
| S | Flags     | Data          | CRC 16  | E |
| O | 8 bits    | (N+1)*16 bits | 16 bits | O |
| F | 0000 0000 |               |         | F |

- **SELECT (25)**

When receiving the Select command:

\_ if the UID is equal to its own UID, the 90129 shall enter the selected state and shall send a response.

\_ if it is different, the 90129 shall stay at previous state and shall not send a response. The Select command must be always in Addressed mode. (The Select\_flag is set to 0. The Address\_flag is set to 1.)

Request format:

|   |           |                   |         |         |   |
|---|-----------|-------------------|---------|---------|---|
| S | Flags     | Read Single Block | UID     | CRC 16  | E |
| O | 8 bits    | 8 bits            | 64 bits | 16 bits | O |
| F | 0010 001x | 0010 0101         |         |         | F |

- **RESET TO READY (26)**

When receiving the Reset To Ready command, the transponder shall return to the Ready state

Request format:

|   |           |                |         |         |   |
|---|-----------|----------------|---------|---------|---|
| S | Flags     | Reset to ready | UID     | CRC 16  | E |
| O | 8 bits    | 8 bits         | 64 bits | 16 bits | O |
| F | 01xx 001x | 0010 0110      |         |         | F |

**MLX90129 custom commands frame contents**

- **READ REGISTER FILE (A01F)**

When receiving the Read register file request, the transponder shall read the requested block from Register File and send back its value in the response.

Request format:

|   |           |                     |            |               |         |   |
|---|-----------|---------------------|------------|---------------|---------|---|
| S | Flags     | Read Register File  | UID        | Block address | CRC 16  | E |
| O | 8 bits    | 8 bits              | 64 bits    | 8 bits        | 16 bits | O |
| F | 00xx 001x | 1010 0000 0001 1111 | (Optional) |               |         | F |

Response format (if no error):

|   |           |         |         |   |
|---|-----------|---------|---------|---|
| S | Flags     | Data    | CRC 16  | E |
| O | 8 bits    | 16 bits | 16 bits | O |
| F | 0000 0000 |         |         | F |

- **WRITE REGISTER FILE (A11F)**

When receiving the Write register file request, the transponder shall write the requested block into Register File with the data contained in the request and report the success of the operation in the response.

Request format:

|   |           |                     |            |               |         |         |   |
|---|-----------|---------------------|------------|---------------|---------|---------|---|
| S | Flags     | Write Register File | UID        | Block address | Data    | CRC 16  | E |
| O | 8 bits    | 8 bits              | 64 bits    | 8 bits        | 16 bits | 16 bits | O |
| F | 00xx 001x | 1010 0001 0001 1111 | (Optional) |               |         |         | F |

- **READ INTERNAL DEVICE (A21F)**

When receiving the “Read Internal Device” request, the transponder shall read a word of the addressed internal device and send back its value in the response. The internal device is selected thanks to the address byte taking part of the command frame.

Request format:

|   |           |                      |            |               |         |   |
|---|-----------|----------------------|------------|---------------|---------|---|
| S | Flags     | Read Internal Device | UID        | Block address | CRC 16  | E |
| O | 8 bits    | 8 bits               | 64 bits    | 8 bits        | 16 bits | O |
| F | 00xx 001x | 1010 0010 0001 1111  | (Optional) |               |         | F |

Response format (if no error):

|   |           |         |         |   |
|---|-----------|---------|---------|---|
| S | Flags     | Data    | CRC 16  | E |
| O | 8 bits    | 16 bits | 16 bits | O |
| F | 0000 0000 |         |         | F |

- **WRITE INTERNAL DEVICE (A31F)**

When receiving the “Write Internal Device” request, the transponder shall write the addressed internal device word. If the address corresponds to the EE-Latches of the Internal Device (Internal Device #03 and #04) the RFID acknowledgment can be missing or the RFID communication can be disabled depending the settings.

The MLX90129 has to be reset (power off) in order to take into account the modifications. The MLX90129 behaviour without reset can not be guaranteed.

Request format:

|   |           |                       |            |               |         |         |   |
|---|-----------|-----------------------|------------|---------------|---------|---------|---|
| S | Flags     | Write Internal Device | UID        | Block address | Data    | CRC 16  | E |
| O | 8 bits    | 8 bits                | 64 bits    | 8 bits        | 16 bits | 16 bits | O |
| F | 00xx 001x | 1010 0011 0001 1111   | (Optional) |               |         |         | F |

- **READ EXTERNAL MEMORY (A41F)**

When receiving the “Read External Memory” request, the transponder shall read the requested block from external memory via SPI and send back its value in the response.

Request format:

|   |           |                      |            |               |         |   |
|---|-----------|----------------------|------------|---------------|---------|---|
| S | Flags     | Read External Memory | UID        | Block address | CRC 16  | E |
| O | 8 bits    | 8 bits               | 64 bits    | 16 bits       | 16 bits | O |
| F | 00xx 001x | 1010 0100 0001 1111  | (Optional) |               |         | F |

Response format (if no error):

|   |           |         |         |   |
|---|-----------|---------|---------|---|
| S | Flags     | Data    | CRC 16  | E |
| O | 8 bits    | 16 bits | 16 bits | O |
| F | 0000 0000 |         |         | F |

- **WRITE EXTERNAL MEMORY (A51F)**

When receiving the “Write external memory” request, the transponder shall send a command to SPI, in order to write a byte into an external memory via SPI interface with the data contained in the request.

Request format:

|   |           |                       |            |               |         |         |   |
|---|-----------|-----------------------|------------|---------------|---------|---------|---|
| S | Flags     | Write External Memory | UID        | Block address | Data    | CRC 16  | E |
| O | 8 bits    | 8 bits                | 64 bits    | 16 bits       | 16 bits | 16 bits | O |
| F | 00xx 001x | 1010 0101 0001 1111   | (Optional) |               |         |         | F |

- **SEND A SPECIFIC COMMAND TO EXTERNAL MEMORY (A61F)**

When receiving the “Send Specific Command to external memory” request, the transponder shall send a command to the external memory via SPI. Example: WREN = Write Enable, Write Disable.

Request format:

|   |           |                     |            |              |         |   |
|---|-----------|---------------------|------------|--------------|---------|---|
| S | Flags     | Send Specific CMD   | UID        | Command code | CRC 16  | E |
| O | 8 bits    | 8 bits              | 64 bits    | 8 bits       | 16 bits | O |
| F | 00xx 001x | 1010 0110 0001 1111 | (Optional) |              |         | F |

- **SEND ADDRESSED COMMAND TO EXTERNAL MEMORY (A71F)**

When receiving the “Send Addressed Command to an external memory” request, the transponder shall send a command and the address to the external memory via SPI. Example: Lock Block, Unlock Block

Request format:

|   |           |                     |            |         |              |         |   |
|---|-----------|---------------------|------------|---------|--------------|---------|---|
| S | Flags     | Send Addressed CMD  | UID        | Address | Command code | CRC 16  | E |
| O | 8 bits    | 8 bits              | 64 bits    | 16 bits | 8 bits       | 16 bits | O |
| F | 00xx 001x | 1010 0111 0001 1111 | (Optional) |         |              |         | F |

- **WRITE EXTERNAL MEMORY STATUS (A81F)**

When receiving the “Write external memory status” request, the transponder shall send specified command with data to the external memory via SPI. Example: write status register.

Request format:

|   |           |                              |            |              |        |         |   |
|---|-----------|------------------------------|------------|--------------|--------|---------|---|
| S | Flags     | Write External Memory Status | UID        | Command Code | Data   | CRC 16  | E |
| O | 8 bits    | 8 bits                       | 64 bits    | 8 bits       | 8 bits | 16 bits | O |
| F | 00xx 001x | 1010 1000 0001 1111          | (Optional) |              |        |         | F |

- **READ EXTERNAL MEMORY STATUS (A91F)**

When receiving the “Read external memory status” request, the transponder shall send specified command to the external memory via SPI and respond with data received from external SPI slave.

Request format:

|   |           |                             |            |              |         |   |
|---|-----------|-----------------------------|------------|--------------|---------|---|
| S | Flags     | Read External Memory status | UID        | Command code | CRC 16  | E |
| O | 8 bits    | 8 bits                      | 64 bits    | 8 bits       | 16 bits | O |
| F | 00xx 001x | 1010 1001 0001 1111         | (Optional) |              |         | F |

Response format (if no error):

|   |           |        |         |   |
|---|-----------|--------|---------|---|
| S | Flags     | Data   | CRC 16  | E |
| O | 8 bits    | 8 bits | 16 bits | O |
| F | 0000 0000 |        |         | F |

-

- **LOCK DEVICE (B01F)**

When receiving the Lock Device request, the transponder switches to Locked state in this case any attempt to have an access to its memory or devices (whether read or write) results with an error response.

Request format:

|   |           |                     |            |         |   |
|---|-----------|---------------------|------------|---------|---|
| S | Flags     | Lock Device         | UID        | CRC 16  | E |
| O | 8 bits    | 8 bits              | 64 bits    | 16 bits | O |
| F | 00xx 001x | 1011 0000 0001 1111 | (Optional) |         | F |

- **UNLOCK DEVICE (B11F)**

When receiving the ‘Unlock device’ request, the transponder shall return device from Locked state. A security procedure based on a password is required to execute the unlocking. The password is in EEPROM #06.

Request format:

|   |           |                     |            |          |         |   |
|---|-----------|---------------------|------------|----------|---------|---|
| S | Flags     | Unlock Device       | UID        | Password | CRC 16  | E |
| O | 8 bits    | 8 bits              | 64 bits    | 16 bits  | 16 bits | O |
| F | 00xx 001x | 1011 0001 0001 1111 | (Optional) |          |         | F |

- **UPDATE REGISTER FILE (C01F)**

Update register file command is used to quick update of contents of Register file via DMA within the image stored in EEPROM.

Request format:

|   |           |                      |            |         |   |
|---|-----------|----------------------|------------|---------|---|
| S | Flags     | Update Register File | UID        | CRC 16  | E |
| O | 8 bits    | 8 bits               | 64 bits    | 16 bits | O |
| F | 00xx 001x | 1100 0000 0001 1111  | (Optional) |         | F |

- **LOCK PAGE (D01F)**

When receiving the ‘Lock Page’ request, the transponder shall lock the requested EEPROM Page.

Request format:

|   |           |                     |            |             |         |   |
|---|-----------|---------------------|------------|-------------|---------|---|
| S | Flags     | Unlock Device       | UID        | Page number | CRC 16  | E |
| O | 8 bits    | 8 bits              | 64 bits    | 8 bits      | 16 bits | O |
| F | 00xx 001x | 1101 0000 0001 1111 | (Optional) |             |         | F |

- **UNLOCK PAGE (D11F)**

When receiving the ‘Unlock Page’ request, the transponder shall unlock the requested Page. A security procedure based on a password is required to execute the unlocking. The password is in EEPROM #06.

Request format:

|   |         |                   |          |             |          |         |   |
|---|---------|-------------------|----------|-------------|----------|---------|---|
| S | Flags   | Unlock Device     | UID      | Page number | Password | CRC 16  | E |
| O | 8 bits  | 8 bits            | 64 bits  | 8 bits      | 16 bits  | 16 bits | O |
| F | xx 001x | 01 0001 0001 1111 | ptional) |             |          |         | F |

## Response error code

If the flag *Error\_flag* of the response is set by the MLX90129, the error code is transmitted to provide some information about the error that occurred. Most of them are described in the standard ISO15693. The last ones are some custom codes.

| Error code | Meaning   | Command           |
|------------|---|-------------------|
| 01         | The command is not supported, i.e. the request code is not recognized | All               |
| 02         | The command is not recognized, for example: a format error occurred   | All               |
| 03         | The option is not supported   | All               |
| 0F         | Unknown error   | All               |
| 10         | The specified block is not available (does not exist)                 | Read/Write/Lock   |
| 11         | The specified block is already locked and thus cannot be locked again | Lock              |
| 12         | The specified block is locked and its content cannot be changed       | Write             |
| A0         | The selected <i>Device</i> is locked                                  | Write memory      |
| A1         | The selected <i>Device</i> is busy (*)                                | Read/Write memory |
| A2         | The access to the selected <i>Device</i> is denied                    | Read/Write memory |

(\*) "*Device is busy*" error code occurring during a write operation means that the MLX90129 is still performing the last write operation. Then, the base-station has to wait for some time and send the command again. For read operation, it means that the selected *Internal device* (sensor ADC,...) cannot read the data and respond immediately.

The purpose of the address #11 in EEPROM is user-defined.

### 8.1.3. RFID interruptions

The Internal device domain contains registers with MLX90129 status information. It can be accessed with the command Read Internal Device.

The following words are part of the Internal Device domain:

- The *RFID core control word* is read/write. It contains a bit used to lock the non-RFID transactions.
- The *RFID interrupt & status word* is read-only. it contains the status of the security units, of the pending accesses to the memories, and of the system current activity.

**RFID core control word** (*Devices address domain*, address #00, read/write)

| Bits                                | Name             | Description (if bit=1)   |
|-------------------------------------|------------------|--|
| <b>#00 – RFID core control word</b> |                  |  |
| 15:1                                | -                | Unused (must be 0)   |
| 0                                   | <b>Core_Lock</b> | When set to '1', it locks any transactions managed by the DMA. This allows having an access from RFID to any device at any time. If base station sets this bit into one, but last transaction inside core is not yet accomplished, this transaction is not interrupted. This signal doesn't block SPI. Priority of this signal is less than priority of such signal in SPI control word, moreover SPI can block affection of this signal (via RFID security map configuration register). |

**RFID interrupt & status word** (*Devices address domain, address #01, read-only*)

| Bits  | Name                           | Description (if bit=1)   |
|---|--------------------------------|--|
| <b>#01 – RFID interrupt &amp; status word</b> |                                |  |
| 15:13   | (reserved)                     |  |
| 12  | <b>Irq_ExternalEvent</b>       | The pin AT has been disconnected from the GND.   |
| 11:8  | (reserved)                     |  |
| 7   | <b>Irq_Sensor_Threshold</b>    | The output data from the sensor has crossed the defined threshold level or window  |
| 6   | <b>Irq_Timer_WakeUp</b>        | The count-down of the wake-up is over  |
| 5   | <b>Irq_DMA_ready</b>           | The DMA transaction has been completed (in the non-loop mode)  |
| 4   | <b>Irq_EEPROM_Full</b>         | The allocated memory for a datalogging with loop enable is full. The datalogger starts to overwrite the first data.  |
| 3   | (unused)                       |  |
| 2   | <b>Transaction_Error_Flag</b>  | One of the previously executed commands has failed (delay not fulfilled, denied access, data not processed ...). This bit is automatically cleared after power-on or after read of the <i>RFID interrupt &amp; status word</i> . |
| 1   | <b>Last_Transaction_Status</b> | This bit indicates whether the last request has been processed ('0') or not ('1'). In this latter case, the MLX90129 ignores any new request.  |
| 0   | <b>Core_Main_Status</b>        | The system is busy with an internal operation and the request from RFID cannot be processed.   |

The following table summarizes the information about the interrupts which can be used with a RFID communication. The *RFID interrupt & status word* in the Internal Device domain at the address 0x01 gives the status of the interruptions. It is read only. It can be accessed with the command Read Internal Device.

For each bit of the *RFID interrupt & status word*, the condition to assert high or low the status flag is described.

| Interrupt description          |  |
|--------------------------------|--|
| <b>Irq_ExternalEvent</b>       |  |
| IRQ enable conditions          | Set to '1' the bits 9 and 11 of the register #12   |
| Status flag is set to '1' when | Pin AT is not connected to GND   |
| Reset condition                | Pin AT is connected to GND   |
| <b>Irq_Sensor_Threshold</b>    |  |
| IRQ enable conditions          | Set to '1' the bits 8,9,10 of the registers #15, #1B, #21  |
| Status flag is set to '1' when | The last ADC output code crosses the defined threshold level or window                           |
| Reset condition                | The chip is requested to read a new value of the sensor  |
| <b>Irq_Timer_WakeUp</b>        |  |
| IRQ enable conditions          | Set to '1' the bit 0 of the register #10   |
| Status flag is set to '1' when | The timer has completed its counting phase   |
| Reset condition                | The timer is requested to start a new counting phase (during the <i>automatic logging mode</i> ) |
| <b>Irq_DMA_ready</b>           |  |
| IRQ enable conditions          | Set to '1' the bit 2 of the register #09   |
| Status flag is set to '1' when | The DMA unit has completed the last requested transaction  |
| Reset condition                | Read the <i>RFID interrupt &amp; status word</i>   |

| Interrupt description          |  |
|--------------------------------|--|
| <b>Irq_EEPROM_Full</b>         |  |
| IRQ enable conditions          | Set to '1' the bits 2 and 3 of the register #09                                    |
| Status flag is set to '1' when | The allocated memory for a datalogging with loop enable is full.                   |
| Reset condition                | Stop the datalogging   |
| <b>Transaction_Error_Flag</b>  |  |
| IRQ enable conditions          | Always enable  |
| Status flag is set to '1' when | When one of previously requested commands was not executed                         |
| Reset condition                | Read the <i>RFID interrupt &amp; status word</i>                                   |
| <b>Last_Transaction_Status</b> |  |
| IRQ enable conditions          | Always enable  |
| Status flag is set to '1' when | A request for a new transaction is pending   |
| Reset condition                | The last requested transaction with the Core has been completed. E.g. ADC is ready |
| <b>Core_Main_Status</b>        |  |
| IRQ enable conditions          | Always enable  |
| Status flag is set to '1' when | The Core is busy with a transaction between different internal devices.            |
| Reset condition                | The Core is not busy with transactions between different internal devices          |

## 8.2. Serial Peripheral Interface (SPI)

### 8.2.1. SPI : modes of operation

The SPI implemented in the MLX90129 works in Slave or Master mode.

- When the MLX90129 SPI is configured in the Slave mode, the SPI master (being a microcontroller, a Zigbee End Device, ...) controls the *serial clock* signal SCK, the *Slave Select* signal SS and transmits the data to the slave via the *Master-Out-Slave-In* signal MOSI. As a slave, the MLX90129 answers with the *Master-In-Slave-Out* signal MISO, synchronized on SCK.
- When configured in the Master mode, the MLX90129 SPI can select an external slave, typically an external serial EEPROM, and use it for data logging. The command op-codes and delays between request and response are programmed in the SPI configuration register. The master SPI controls the *Slave Select*, the *Serial Clock* signal, sends the data on MOSI and read data on MISO. It is possible to control the SPI as master thanks to custom RFID commands.

SPI is compliant with the following control options:

- Master mode and Slave mode
- CPOL=0: The clock is active-high: in the idle mode, SCK is low.
- CPHA=0: Sampling of data occurs on rising edges of SCK. Toggling of data occurs on falling edges.
- MSB first (on MISO and MOSI)
- Baud-rate: 1MHz

Detailed signal description:

- **MOSI** : this pin is used to transmit data out of the SPI module when it is configured as a Master and receive data when it is configured as a Slave.
- **MISO** : this pin is used to transmit data out of the SPI module when it is configured as a Slave and receives data when it is configured as a Master.
- **SS** : when the MLX90129 is configured as a SPI master, it controls the SS pin to select an external peripheral with which a data transfer will take place. When configured as a Slave, it is used as an input to receive the *Slave Select* signal.
- **SCK** : this pin is used to output or receive the clock.
- **IRQ** : this pin is used to interrupt the SPI master (microcontroller) process.

When the MLX90129 is not selected by the SPI master or when the received command code is not supported, the pin MISO is in tri-state. When the MLX90129 uses the SPI in the master mode (to access an external memory), it complies with the same rules for any external SPI masters.

### 8.2.2. Slave SPI command set

#### SPI command set

| Command  | Code | Operation   |
|----------|------|---|
| EEP_RD   | 0x0F | Read the addressed EEPROM word  |
| EEP_WR   | 0x0E | Write the addressed EEPROM word   |
| REG_RD   | 0x0D | Read the addressed register in the <i>Register File</i>                             |
| REG_WR   | 0x09 | Write the addressed register in the <i>Register File</i>                            |
| DEV_RD   | 0x10 | Read a word from the selected <i>internal device</i> (Control, status, ADC,...)     |
| DEV_WR   | 0x18 | Write a word into the selected <i>internal device</i> (Control, ee-Latches )        |
| REG_UPDT | 0x1C | Fills the <i>Register File</i> with its image stored in the EEPROM (without reboot) |

### 8.2.3. SPI interruptions

The SPI I/O signals are accompanied of an output interrupt signal IRQ. This signal may be used to wake up or to warn the SPI master (micro-controller) about some access conflicts or some general problems (low battery level, external event ...). It is set once one of the selected events occur. It is reset once the SPI master has read the *SPI Core interrupt / status word*, or has set the bit *Disable IRQ setting* of the *SPI Core control word*.



SPI Core control word (Device address domain, address #00, read/write)

| Bits                               | Name                          | Description (if bit=1)   |
|------------------------------------|-------------------------------|--|
| <b>#00 – SPI Core control word</b> |                               |  |
| 15:7                               | -                             | Reserved (must be 0)   |
| 6                                  | <b>Irq_Rfid_Reg_Access_En</b> | <i>RFID interrupts control:</i><br>Enable RFID Interrupt 2 (Access to Register file).  |
| 5                                  | <b>Irq_Rfid_EEp_Access_En</b> | Enable RFID Interrupt 1 (Access to EEPROM).  |
| 4                                  | <b>Irq_Rfid_Field_En</b>      | Enable RFID Interrupt 0 (RFID field is detected).  |
| 3                                  | <b>Irq_Last_Trans_En</b>      | <i>End of transaction</i><br>Enable interrupt indicating the completion of the last requested transaction. To de-assert this interrupt, the user will request another transaction, read the SPI local data buffer (in device address domain), disable this interrupt or block IRQ assertion. |
| 2                                  | <b>Irq_Dis</b>                | <i>Disabled IRQ setting.</i><br>Disable the setting of the IRQ signal.   |
| 1                                  | <b>Core_Sts_Irq_En</b>        | <i>Core status interrupt enabled.</i><br>Enable the interrupt on IRQ telling that the system is free.  |
| 0                                  | <b>Core_Lock</b>              | <i>Core lock.</i><br>Lock any transactions between the different internal devices and the non-SPI interfaces. This allows having an access from SPI to any registers at any time. The last pending transaction is always completed.  |

**SPI interrupt & status word** (*Devices address domain, address #01, read only*)

| Bits   | Name                           | Description (if bit=1)   |
|--|--------------------------------|--|
| <b>#01 – SPI interrupt &amp; status word</b> |                                |  |
| 15:13  | (reserved)                     |  |
| 12   | <b>Irq_ExternalEvent</b>       | The pin AT has been disconnected from the GND.   |
| 11   | (reserved)                     |  |
| 10   | <b>Irq_Rfid_Reg_Access</b>     | The RFID interface is accessing the Register File  |
| 9  | <b>Irq_Rfid_EEp_Access</b>     | The RFID interface is accessing the EEPROM   |
| 8  | <b>Irq_Rfid_Field</b>          | The magnetic field is high enough to start a RFID communication  |
| 7  | <b>Irq_Sensor_Threshold</b>    | The output data from the sensor has crossed the defined threshold level or window  |
| 6  | <b>Irq_Timer_WakeUp</b>        | The count-down of the wake-up is over  |
| 5  | <b>Irq_Dma_Ready</b>           | The DMA transaction has been completed (in the non-loop mode)  |
| 4  | <b>Irq_Memory_Full</b>         | The allocated memory for a datalogging with loop enable is full. The datalogger starts to overwrite the first data.  |
| 3  | <b>Irq_Write_Failure</b>       | The non-volatile block has been written bad or weak: the data is wrong or its long-term retention is not guaranteed  |
| 2  | <b>Transaction_Error</b>       | One of the previously executed commands has failed (read delay, denied access, data not processed,...). This bit is automatically cleared after reboot or after read of the <i>SPI interrupt &amp; status word</i> . |
| 1  | <b>Last_Transaction_Status</b> | This bit indicates whether the last request from SPI has been processed ('0') or not ('1'). In this latter case, the MLX90129 ignores any new request from SPI.  |
| 0  | <b>Core_Main_Status</b>        | The system is busy with an internal operation and the request from SPI cannot be processed immediately.  |

The following table summarizes the information about the interrupts. For each bit of the *SPI interrupt & status word*, the condition to assert high or low the status flag, is described. All interrupts can be disabled in asserting high the bit *Irq\_Dis* of the *SPI Core control word*.

| Interrupt description          |  |
|--------------------------------|--|
| <b>Irq_ExternalEvent</b>       |  |
| IRQ enable conditions          | Set to '1' the bits 9 and 11 of the register #12                                   |
| Status flag is set to '1' when | Pin AT is not connected to GND   |
| Reset condition                | Pin AT is connected to GND   |
| <b>Irq_Rfid_Reg_Access</b>     |  |
| IRQ enable conditions          | Set to '1' the bit 4 of the internal device #00 ( <i>SPI Core control word</i> )   |
| Status flag is set to '1' when | A RFID reader is accessing the register file                                       |
| Reset condition                | Read the <i>SPI interrupt &amp; status word</i>                                    |
| <b>Irq_Rfid_EEp_Access</b>     |  |
| IRQ enable conditions          | Set to '1' the bit 5 of the internal device #00 ( <i>SPI Core control word</i> )   |
| Status flag is set to '1' when | A RFID reader is accessing the EEPROM  |
| Reset condition                | Read the <i>SPI interrupt &amp; status word</i>                                    |
| <b>Irq_Rfid_Field</b>          |  |
| IRQ enable conditions          | Set to '1' the bit 6 of the internal device #00 ( <i>SPI Core control word</i> )   |
| Status flag is set to '1' when | A RFID field has been detected, and is strong enough to start a RFID communication |
| Reset condition                | The RFID field has been removed, or is too low for a RFID communication            |

| Interrupt description          |  |
|--------------------------------|--|
| <b>Irq_Sensor_Threshold</b>    |  |
| IRQ enable conditions          | Set to '1' the bits 8,9,10 of the registers #15, #1B, #21  |
| Status flag is set to '1' when | The last ADC output code crosses the defined threshold level or window                           |
| Reset condition                | The chip is requested to read a new value of the sensor  |
| <b>Irq_Timer_WakeUp</b>        |  |
| IRQ enable conditions          | Set to '1' the bit 0 of the register #10   |
| Status flag is set to '1' when | The timer has completed its counting phase   |
| Reset condition                | The timer is requested to start a new counting phase (during the <i>automatic logging mode</i> ) |
| <b>Irq_DMA_ready</b>           |  |
| IRQ enable conditions          | Set to '1' the bit 2 of the register #09   |
| Status flag is set to '1' when | The DMA unit has completed the last requested transaction  |
| Reset condition                | Read the <i>SPI interrupt &amp; status word</i>  |
| <b>Irq_EEPROM_Full</b>         |  |
| IRQ enable conditions          | Set to '1' the bits 2 and 3 of the register #09  |
| Status flag is set to '1' when | The allocated memory for a datalogging with loop enable is full.                                 |
| Reset condition                | Stop the datalogging   |
| <b>Irq_Write_Failure</b>       |  |
| IRQ enable conditions          | Always enable  |
| Status flag is set to '1' when | When one of the previously requested write-operations to a non-volatile memory has failed        |
| Reset condition                | Read the <i>SPI interrupt &amp; status word</i>  |
| <b>Transaction_Error_Flag</b>  |  |
| IRQ enable conditions          | Always enable  |
| Status flag is set to '1' when | When one of previously requested commands was not executed                                       |
| Reset condition                | Read the <i>SPI interrupt &amp; status word</i>  |
| <b>Last_Transaction_Status</b> |  |
| IRQ enable conditions          | Always enable  |
| Status flag is set to '1' when | A request for a new transaction is pending   |
| Reset condition                | The last requested transaction with the Core has been completed. E.g. ADC is ready               |
| <b>Core_Main_Status</b>        |  |
| IRQ enable conditions          | Always enable  |
| Status flag is set to '1' when | The Core is busy with a transaction between different internal devices.                          |
| Reset condition                | The Core is not busy with transactions between different internal devices                        |

### 8.3. Management of communication conflicts

Core Transaction Arbiter

Part of the *Digital Controller*, the “*Core transaction arbiter*” deals with several tasks:

- Grant or deny accesses of the communication interfaces to the different memories
- Manage the interrupts
- Update the status of the current operations

#### Memory access conflicts between SPI, RFID and DMA

The two communication channels, SPI and RFID, and the internal DMA (*Direct Memory Access*) are able to access the memories (EEPROM, registers...) or the sensor *ADC buffer*, at the same time. The potential access conflicts are managed by the *Core transaction arbiter*. A DMA transaction may be interrupted by a RFID or a SPI starting communication. The RFID (resp. SPI) transaction cannot be interrupted by a starting SPI (resp. RFID) communication, or a DMA operation. In each case, the current transaction is completed.

The priority order is the following:

1. SPI (highest priority)
2. RFID
3. DMA

#### Management of two subsequent transactions, from the same communication channel:

A transaction initiated via RFID or SPI should be completed before starting a new one. If a request is sent to the MLX90129 by a SPI master, or by a RFID base-station, and the current transaction is not completed, then it is dealt differently depending on its nature:

- \_ the reading of the *Core interrupt / status word* is allowed at any time and its content is sent in the response.
- \_ the reading of a memory (a register or an EEPROM word) is denied and an error-message response may be sent. For the SPI, it contains 0xFFFF. For the RFID, the content of the response is described in the standard protocol.
- \_ if the request is not understood, it is not processed, and a flag is set in the *Core interrupt / status word*. This flag is reset once it has been read.

#### The Core interrupt / status word (Internal device #01)

The *Core transaction arbiter* updates its *Core interrupt / status word* at each transaction. This status word is read-only and contains some information about the processing of the incoming request. It indicates:

- \_ whether the system is busy or not
- \_ whether the last request has been processed
- \_ whether the processing of the last request has failed
- \_ the source(s) of the interrupt, if the interrupt signal on pin IRQ is asserted ‘1’.

One *Core interrupt / status word* is associated to each communication way (SPI or RFID). Its content is explained in the chapters dedicated to RFID and to SPI.

#### The Core Control Word (Internal device #00)

The *Core transaction arbiter* updates its *Core control word* at each transaction. This status word is read/write and contains the settings used to control the interrupt signal IRQ, and the potential interrupts from other communication channel. One *Core control word* is associated to each communication way (SPI or RFID). Its content is explained in the chapters dedicated to RFID and to SPI.

## 9. Device Configuration

### 9.1. Standalone datalogger

#### 9.1.1. Main features

The Datalogger application is managed by the DMA (Direct Memory Access) unit. This block controls the standalone applications, without any external microcontroller. It handles the start-up operations, and sends the data from a programmed source towards a programmed destination, using flexible protocol and interrupt conditions. Typically, it may get the data from the sensor interface and store it in an EEPROM. It works on defined time periods controlled by a wake-up timer.

Its main features are the following:

- The configuration registers are filled from the EEPROM at the start-up (when enabled)
- The duty-cycle (ratio between active and sleep mode) is controlled by a wake-up timer (WUT) that wakes the system up after a programmed delay
- Programmed behaviour (source, destination, interrupt options, master-SPI options, ...)
- Programmable command-set to address any kind of external SPI memory
- Programmable timings used in the SPI protocol of the external memory (between the request and the response)
- Calculation of the address of the destination.

#### 9.1.2. DMA operations

##### Loading of the register file from the EEPROM data.

At the power-up of the battery, the DMA automatically loads the *Register File* with its image from the EEPROM. A bit stored in the EE-Latch bank, called *Disable Automatic Loading*, can be set to disable this automatic loading.

At any time, the RFID or the SPI interface can send an *Update* command to update the content of the *Register File* with the values stored in the EEPROM.

The configuration may be chosen in such a way that DMA operations start automatically at power-up.

##### Data logging in the internal or external EEPROM

After power-up, the DMA loads the *Register File* with the data stored in the EEPROM (it also loads its own configuration).

The wake-up timer (WUT) starts counting to a programmed value. During this counting, the MLX90129 works in a *sleep mode*, consuming a very low power. To save power, the duty cycle should be as low as possible.

At the end of the counting, the WUT wakes the DMA up.

The DMA loads the configuration registers of the selected sensor, and starts a sensor acquisition.

The result data is then stored in the EEPROM, at an address calculated from a programmed value. Depending on the options, the DMA may configure and start an acquisition of another sensor, or may let the system enter the *sleep mode*. If another sensor is selected, then the DMA loads the new sensor configuration before starting the acquisition.

At any moment, this process may be interrupted by an external microcontroller, to read the data collection. For that, it asserts low the bit *Processing Control* of the *DMA configuration register*. Then, the process may be hold or reset. In order to store only the latest data from ADC, the bit *Loop enable* must be set. In this case, the old data is rewritten by the DMA unit with the new one when the memory border has been reached. When the memory is completely filled, a *Full Memory* interrupt appears on the pad IRQ. It is also possible to send an interrupt request (IRQ) to the external microcontroller after each Wake-up timer period. Then, the micro-controller may decide to read the sensor output data and process it.

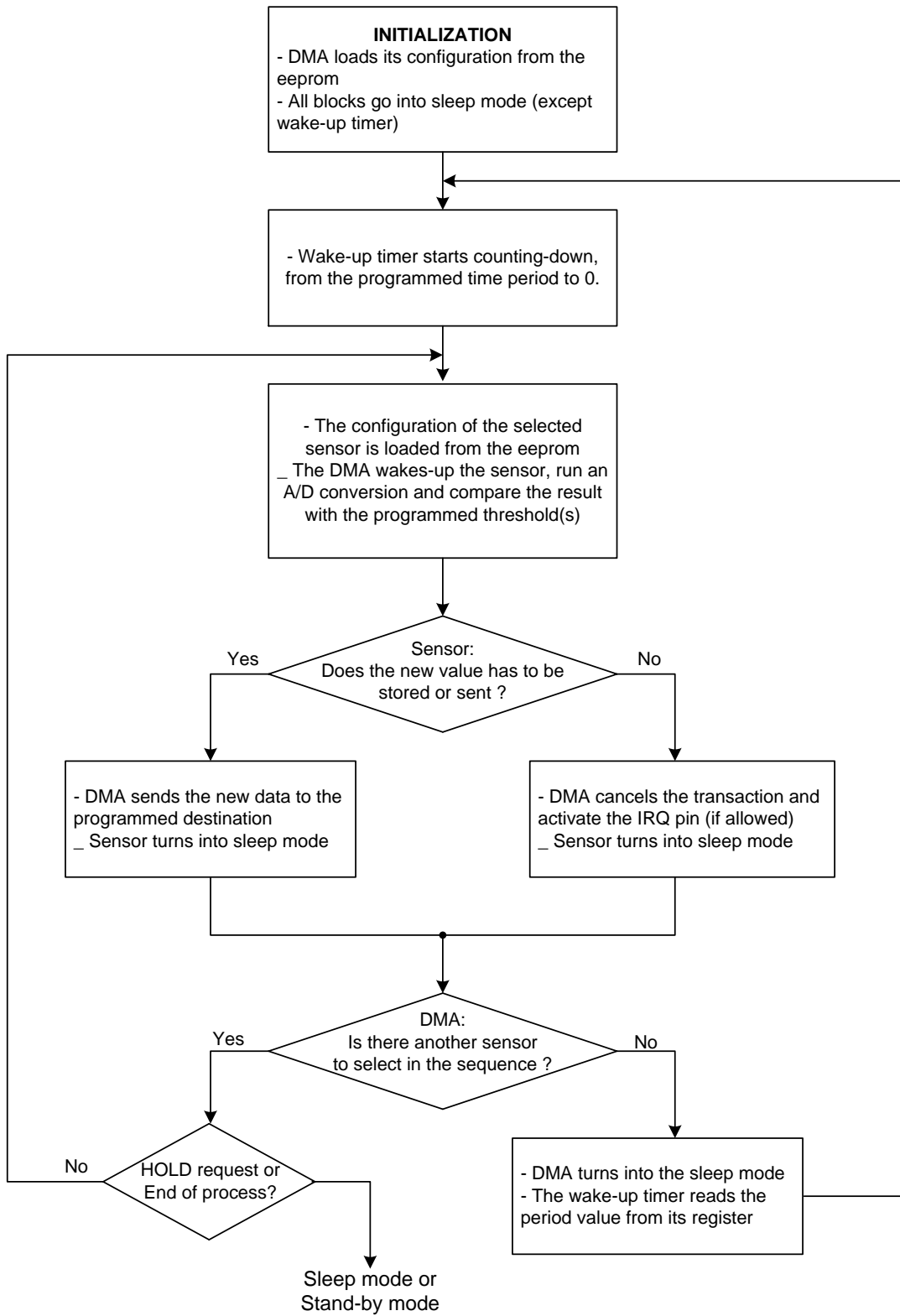

**Interrupt of DMA process**

The microcontroller or the RFID base-station can read the *DMA status register* and access the *DMA configuration register* to start and control the DMA processing. At any time, they can hold the DMA process and check the current status of the copied data (telling how many words have been copied). Then, they can change the DMA configuration to a new one or continue the processing. While the DMA is processing data or is on hold, any change of the parameters in the DMA configuration words does not cause the expected changes in the behaviour.

**End of DMA process**

At the end of the sequence, the MLX90129 may enter its sleep mode or its stand-by mode. During the *Sleep mode*, the system may be interrupted by a RFID field, or by the SS line asserted low during 1.5ms.

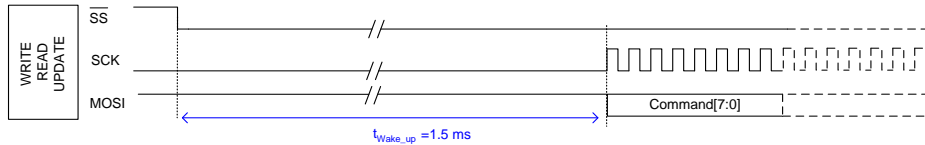

**9.1.3. Setup of the Automatic Logging Mode**

**Setup**

In order to enable the *automatic logging mode*, the following sequence must be run:

- \_ Setup the *DMA configuration word*
- \_ Setup the *DMA source start address, DMA destination start address* and the *DMA length*.
- \_ If an external EEPROM is used, setup the *SPI-master configuration and command word*
- \_ setup the sensor interface configurations in the EEPROM.
- \_ Setup the Sensor control word and the Sensor thresholds words (if required)
- \_ Setup the Wake-up Timer configuration word
- \_ Setup the logging period in the wake-up timer
- \_ To enable the DMA operation, the bit *Processing Control* of the *DMA configuration register* must be reset.
- \_ Set the bit *Automatic Logging enable* in the wake-up timer configuration to '1'.

All these actions can be performed automatically after the system boot: the required configuration can be set in the EEPROM. Then, after power-on, the system reads this configuration and performs the programmed actions. It is not mandatory to store all the data from a sensor at each iteration, but only the data fitting the conditions defined in the bits *Data logging control* of the register word called *Sensor[x] Control word*.

**Logging several sensors and time-stamp**

When more than one sensor is selected as a source of automatic logging, the DMA stores subsequently all the sensor output data in the selected memory. The stored data has a prefix to identify them:

|                   |        |                 |
|-------------------|--------|-----------------|
| <b>Bit</b>        | 15:14  | 13:0            |
| <b>Definition</b> | Prefix | ADC output code |

The prefix code is defined in the following table:

| Prefix code | Related sensor or parameter  |
|-------------|------------------------------|
| 00          | Sensor 0                     |
| 01          | Sensor 1                     |
| 10          | Sensor 2                     |
| 11          | Iteration index (Time stamp) |

### 9.1.4. Direct Memory Access configuration

DMA configuration words (EEPROM & Register, address #09 to #0C, read/write)

| Bits  | Name                           | Description (when bit = '1')  |
|---|--------------------------------|---|
| <b>#09 – DMA Control word</b>               |                                |   |
| 15:12                                       |                                | <i>Sensing sequence</i>   |
| 15  | <b>DMA_Time_Incl</b>           | include the iteration index (time stamp) in the memory  |
| 14  | <b>DMA_Sensor2_Incl</b>        | include the measurement and the storing of sensor 2   |
| 13  | <b>DMA_Sensor1_Incl</b>        | include the measurement and the storing of sensor 1   |
| 12  | <b>DMA_Sensor0_Incl</b>        | include the measurement and the storing of sensor 0   |
| 10:11                                       |                                | Reserved (must be 00)   |
| 9   | <b>DMA_LastWordMask</b>        | Disable the copying of the LSB (byte) of the last word in the datalogging sequence in the external EEPROM   |
| 8   | <b>DMA_FirstWordMask</b>       | Disable the copying of the MSB (byte) of the first word in the datalogging sequence in the external EEPROM  |
| 7:6   | <b>DMA_DestinationCode</b>     | <i>Destination of the data transfer</i><br>00 : register file<br>01 : internal EEPROM*<br>10 : SPI as master (external EEPROM)<br>11 : (reserved)   |
| 5:4   | <b>DMA_SourceCode</b>          | <i>Source of the data transfer</i><br>00 : (reserved)<br>01 : internal EEPROM<br>10 : SPI as master (external EEPROM)<br>11 : Sensor interface  |
| 3   | <b>DMA_LoopEn</b>              | Enable an eternal loop of data logging. In this case, after having copied <i>Length</i> words, the DMA unit does not stop its operation but sets its address to the initial one and goes on copying data. |
| 2   | <b>DMA_IrqDataReady_En</b>     | <i>IRQ Data-transfer enabled.</i> The IRQ signal is set when the data transfer has been completed.  |
| 1   | <b>DMA_Hold</b>                | <i>Hold.</i> The DMA holds its operation till this bit goes low. The current ongoing DMA transaction is always completed.   |
| 0   | <b>DMA_Processing_Control</b>  | <i>Manual processing control.</i><br>'0': Manual stop of DMA (used for automatic data-logging )<br>'1': Manual start of DMA (not for automatic data-logging)  |
| <b>#0A – DMA: Source start address</b>      |                                |   |
| 15:0  | <b>DMA_Source_Address</b>      | Address of the first word to be copied from the source device.  |
| <b>#0B – DMA: Destination start address</b> |                                |   |
| 15:0  | <b>DMA_Destination_Address</b> | Address of the first word to be filled into the destination device.*  |
| <b>#0C – DMA: Length</b>                    |                                |   |
| 15:0  | <b>DMA_Data_Length</b>         | Length of the block to be copied (in words).*   |

\* /!\ in case of datalogger application with sensor data logged into the MLX90129 internal EEPROM, care should be taken to not overwrite the configuration value in EEPROM [from #00 to #28]. For this reason:

- DMA\_Destination\_Address should be at least 0x29
- DMA\_Data\_Length should have the maximum value of 0xD7 ( in case of DMA\_Destination\_Address is 0x29) in order to not exceed the address 0xFF



**DMA status register** (Device Address Domain, #05, read only)

| Bits                             | Name                                   | Description  |
|----------------------------------|--|--|
| <b>#05 - DMA status register</b> |  |  |
| 15:0                             | <b>DMA_Current_Destination_Address</b> | Address of the block of memory in the destination address domain (which is still not filled with data from the source device). |

### 9.1.5. Wake-up timer / Power management configuration

The Wake-up timer is used for two purposes:

- to wake-up the microcontroller after a defined delay via the IRQ pin
- to enable and sequence the periodical logging of data from the sensor
- to enter the stand-by mode after a programmed delay

The following table contains the control options of this timer:

#### Wake-up timer (WUT) / Power management configuration words

(EEPROM & register, addresses #0F and #10, read / write)

| Bits                            | Name                       | Description (when =1)   |
|---------------------------------|----------------------------|---|
| <b>#10 – Timer Control word</b> |                            |   |
| 15:6                            | -                          | Reserved (must be 0)  |
| 5:4                             | <b>WUT_Precision</b>       | <b>Precision.</b> Defines the time unit for the specified timer wake-up period (called <i>Count-down period</i> ).<br>00: time in ms<br>01: time in s<br>10: time in min<br>11: time in hours   |
| 3                               | <b>WUT_AutoStandby_En</b>  | <b>Automatic stand-by enabled.</b> Allow the MLX90129 to automatically enter the stand-by mode after the end of the wake-up timer count-down, or after completion of the automatic logging (if it is enabled).  |
| 2                               | <b>WUT_AutoLog_En</b>      | <b>Automatic logging mode enabled.</b> If this bit is set to '1', the wake-up timer loads its value from the Register file and starts a count-down. As soon as it reaches 00h, it allows to run one or several sensor acquisitions and to store the data in the programmed destination. Then, it loads its count-down period again and starts counting. This process may be halted by resetting this bit to '0'.              |
| 1                               | -                          | . Reserved (must be 0)  |
| 0                               | <b>WUT_Irq_En</b>          | <b>Timer IRQ enabled.</b> The timer starts its operation and generates IRQ signal after passing specified period.   |
| <b>#0F – Timer period</b>       |                            |   |
| 15:0                            | <b>WUT_CountDownPeriod</b> | Combined with the <b>WUT_Precision</b> , this parameter defines the period between two measurements. If N is the conversion into decimal value of the <b>WUT_CountDownPeriod</b> hexadecimal value, the nominal logging period will be:<br>WUT_Precision = 00 -> Period = N * 0.9765625 ms<br>WUT_Precision = 01 -> Period = N * 1 s<br>WUT_Precision = 10 -> Period = N * 1 min<br>WUT_Precision = 11 -> Period = N * 1 hour |

## 9.1.6. Master SPI configuration

A bit of the *Device security map* is used to set the SPI as master. Then, the MLX90129 controls the clock SCK, the slave-select SS (output), and the communication I/O MOSI (output) and MOSI (input).

The SPI configuration words are used to setup the parameters of the SPI-master interface, in order to access an external memory (a serial SPI EEPROM). In master mode, the SPI may be used by the internal DMA unit (Direct Memory Access) to store the output data of the sensor. The stored data may be read back by a RFID base-station.

**Master SPI configuration words** (EEPROM & Register, #0D and #0E, read/write)

| Bits  | Name                    | Description  |
|---|-------------------------|--|
| <b>#0D – External memory control word</b>       |                         |  |
| 15:8  | <b>SPI_WriteEn_Code</b> | <b>Write enabled command code.</b> Command op-code of the “write enable” operation, used toward an external EEPROM.  |
| 7   | <b>SPI_BurstMode_En</b> | <b>Burst mode enable:</b> enable the write burst mode used in some SPI serial EEPROM. (*)  |
| 6:4   | <b>SPI_WriteDelay</b>   | <b>Write delay.</b> Delay which is inserted between a write command and another subsequent command. Precision is 4 ms. Minimal write delay calculation equation, when value of this field is non-zero: $t_{WC} = 4 \times \text{WriteDelay} - 1$ (ms). |
| 3:2   | <b>SPI_WriteEn_Ctrl</b> | <b>Write enable operation control.</b> Defines when the <i>Write Enable</i> command must be applied:<br>00 - never<br>01 - reserved<br>10 - before every write operation<br>11 - reserved  |
| 1:0   | <b>SPI_AddressMode</b>  | <b>Addressing mode.</b> Defines the address length to be passed via SPI for a proper EEPROM addressing.<br>00 - 8-bit address is used<br>01 - 16-bit address is used<br>10 - 24-bit address is used (8 MSB are filled with 00)<br>11 - reserved        |
| <b>#0E – External memory command codes word</b> |                         |  |
| 15:8  | <b>SPI_WriteCode</b>    | <b>Write command code.</b> Command op-code used by MLX90129 to write in an external memory block   |
| 7:0   | <b>SPI_ReadCode</b>     | <b>Read command code.</b> Command op-code used by MLX90129 to read from an external memory block   |

(\*) Note:

The setting of the bit *Burst mode enable* switches all subsequent transactions with an external memory into burst mode. It means, that only the first memory access transaction requires sending a command and an address. After completion of this first transaction, the master SPI of the MLX90129 does not set the SS signal to ‘1’. When a new block has to be read / written, the SPI master skips the command and address phases and immediately sends or receives data to or from the external memory (it allows a page access).

## 9.2. Sensor Signal Conditioner

### 9.2.1. Block description

The sensor signal conditioner amplifies and filters the sensor output signal, before converting it to a digital format.

These are its main features:

- Two programmable gain amplifiers (PGA1 and PGA2)
- Programmable offset level (DAC)
- 16-bit A/D converter
- Internal temperature sensor
- Two selectable external differential or single-ended sensors
- Voltage regulator, to supply internal and external devices
- Programmable serial resistor connected to the external sensors

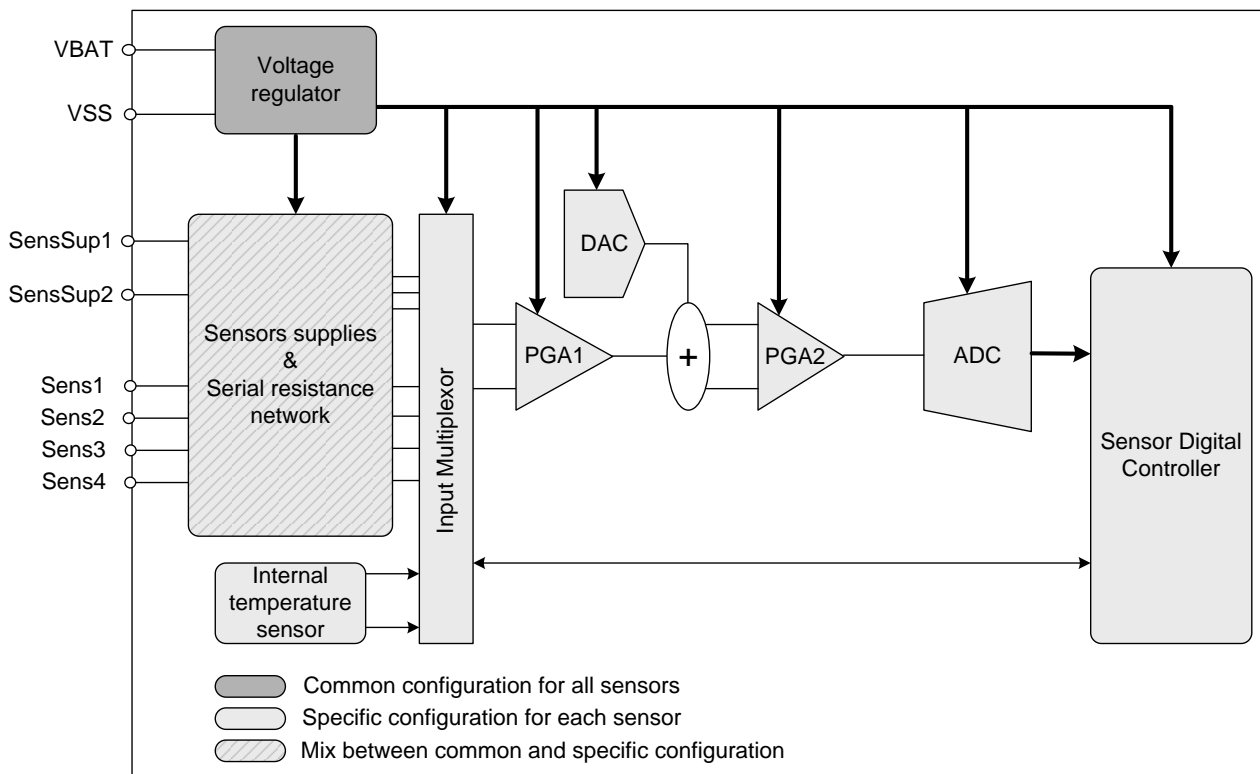

#### Voltage regulator

This block provides the signal conditioner chain and the external sensors with a programmable, stable voltage for a wide range of sourced currents.

#### Internal temperature sensor

This block gives a temperature-dependent voltage. As all other sensors, it must be calibrated to give accurate data.

**Sensor supplies & Resistor network**

Many combinations of resistors connections with the external sensors are possible. All the switches figured on the following schematic are independently programmable via register #1A. The supply VREF is the stabilized output of the voltage regulator. The configuration register #19 is used to connect an external sensor or internal resistance to the inputs of the analog chain (called MUX OUT1 and MUX OUT2).

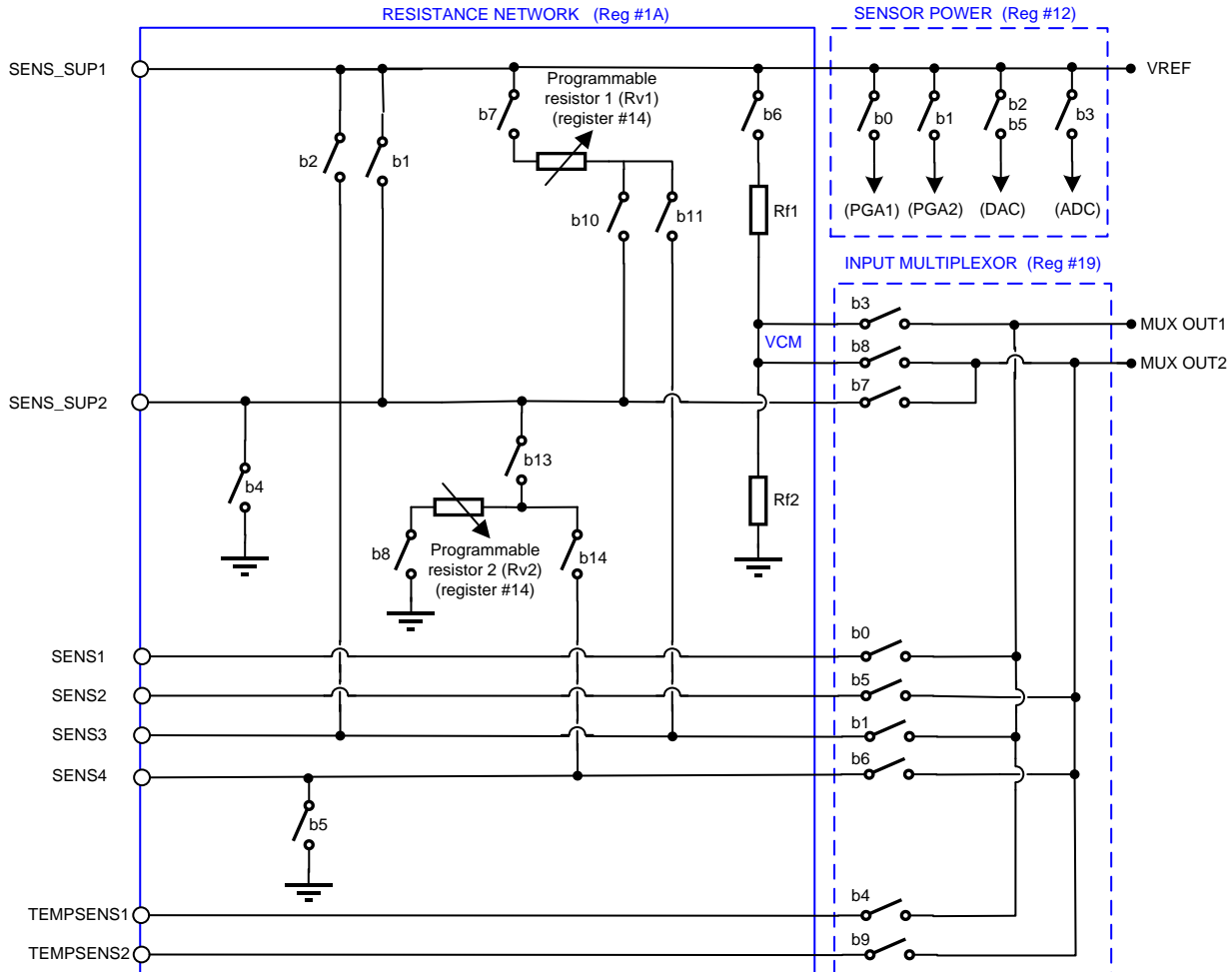

**Input multiplexer**

This block allows selecting the sensor signal which will be connected to the first amplifier of the signal conditioner. It is possible to select the external sensor(s) connected to SENS1, SENS2, SENS3 and SENS4, or the internal temperature sensor.

**Programmable amplifier 1 (PGA1)**

This block is the first programmable amplifier of the analog chain. It has a wide range of gain and is fully differential. It is compliant with a wide range of input common-mode voltage.

$$\Delta\text{PGA1\_Out} = \text{Gain1} * \Delta\text{PGA1\_In}$$

Where:

$\Delta\text{PGA1\_Out}$  is the differential output voltage of the Programmable Amplifier 1

Gain1 is the gain of the Programmable Amplifier 1

**D/A converter (DAC)**

This block is used to compensate the offset of the sensor and of PGA1, amplified by PGA1. It is also used to choose the value of the physical sensed value, for which the ADC will give its middle code.

## MLX90129

13.56MHZ SENSOR TAG / DATALOGGER IC

### Programmable amplifier 2 (PGA2)

This block amplifies (with a programmable gain) the output voltages of PGA1 and of the DAC, following the equation:

$$\Delta\text{PGA2\_Out} = \text{Gain2} * [\Delta\text{PGA1\_Out} - \Delta\text{DAC\_Out}]$$

Where:

$\Delta\text{PGA1\_Out}$  is the differential output voltage of the Programmable Amplifier 1

$\Delta\text{PGA2\_Out}$  is the differential output voltage of the Programmable Amplifier 2

$\Delta\text{DAC\_Out}$  is the differential output voltage of D/A converter

Gain2 is the gain of the Programmable Amplifier 2

### A/D converter (ADC)

This block converts into a digital format the output voltage of PGA2.

**Sensor Digital Controller**

The main features of the sensor digital controller block are:

- Initialization of the sensor interface, and running of the A/D conversions
- Buffer the ADC output code (in one of the 3 ADC buffers) when conversion has been completed
- Digital data processing: main calculation, comparison with threshold values
- Take the decision to store the data, and/or configure the conditions to generate an interrupt on IRQ.

Before any A/D conversion, the configuration of the sensors must be stored in the register file at addresses from #12 to #1A. Each sensor has its configuration stored in EEPROM. Depending on the selected sensor, the appropriate data will be copied from EEPROM to the register file.

The configuration of the selected sensor is automatically loaded from EEPROM when:

- Using commands Read Internal Device #07, Read Internal Device #08, for the first time.
- Using a command Read Internal Device #XX different from the previous one.

The configuration of the selected sensor is **not** automatically loaded from EEPROM when:

- Using command Read Internal Device #06, for the first time.
- Using the same command Read Internal Device as the previous one.

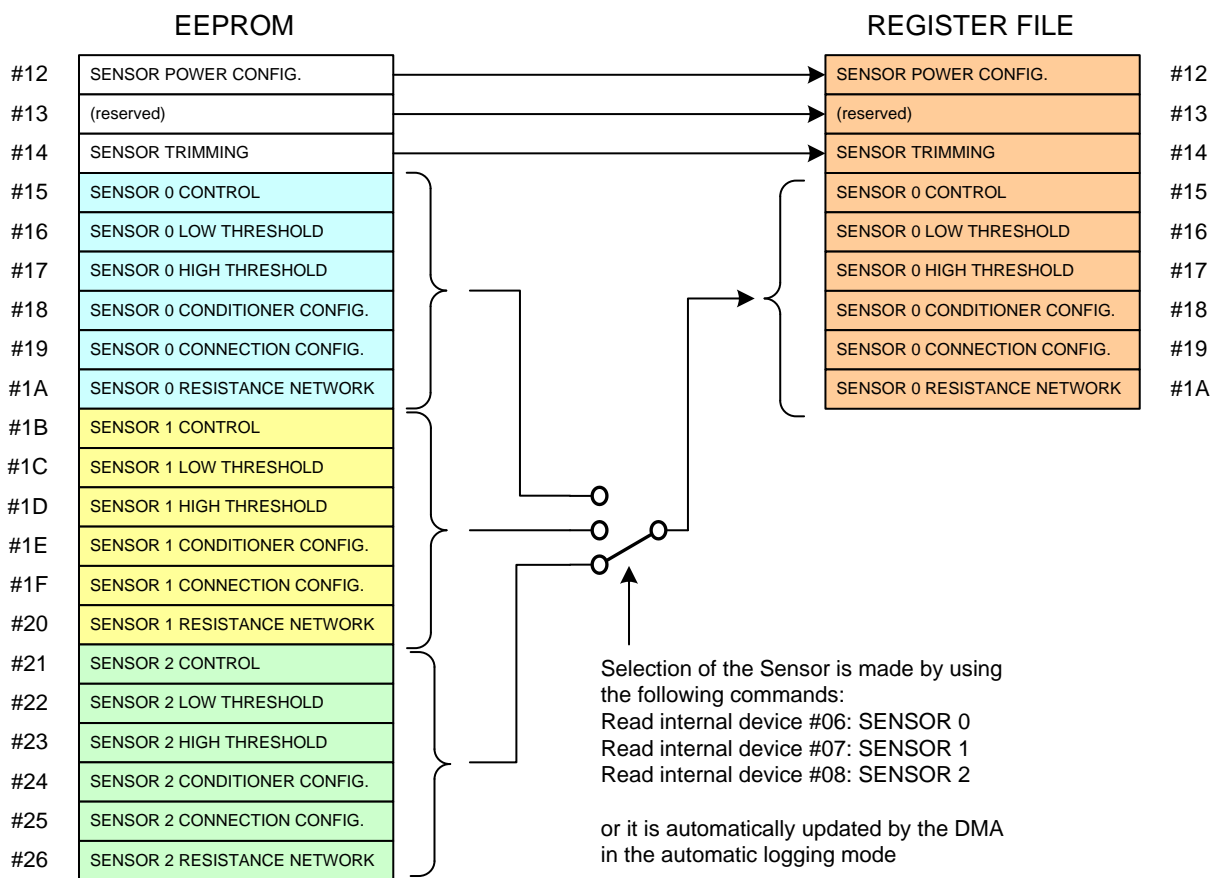

**9.2.2. Sensors common configuration**

The following registers manage the sensor power configuration and the trimming of the internal resistor. This configuration is applicable for all the sensors.

**Sensor’s power configuration words (EEPROM & Register, #12, read / write)**

The sensor's power configuration register allows disabling unused blocks in order to save power.

| Bits  | Name                  | Content   | 0= not powered (disabled) | 1= powered (enabled) |
|---|-----------------------|---|---------------------------|----------------------|
| <b>#12 – Sensors power configuration word</b> |                       |   |                           |                      |
| 0   | Sensor_Pga1_En        | PGA1 enable bit   |                           |                      |
| 1   | Sensor_Pga2_En        | PGA2 enable bit   |                           |                      |
| 2   | Sensor_Dac_En         | DAC enable bit  |                           |                      |
| 3   | Sensor_Adc_En         | ADC enable bit  |                           |                      |
| 4   | Sensor_Reg_En         | Voltage Regulator enable bit  |                           |                      |
| 5   | Sensor_DacBuf_En      | DAC buffer enable bit   |                           |                      |
| 6   | Sensor_Bias_En        | Bias block enable bit   |                           |                      |
| 7   | Sensor_Temp_En        | Temperature sensor enable bit   |                           |                      |
| 8   | (not used, must be 0) |   |                           |                      |
| 9   | Sensor_Ats_Pwr_En     | Event detector power-on bit   |                           |                      |
| 10  | (not used, must be 0) |   |                           |                      |
| 11  | Sensor_Ats_En         | Event detector enable bit   |                           |                      |
| 12  | (not used, must be 0) |   |                           |                      |
| 13  | ExtSupplyMode         | 0: the regulator always supplies the external device<br>1: the regulator supplies it only in its watchful state (to save power) |                           |                      |
| 15:14   | (not used, must be 0) |   |                           |                      |

#### Sensor's common configuration words (EEPROM & Register, #13 and #14, read / write)

This EEPROM-word is used to trim the value of the programmable serial resistance connected to the sensor. Serial resistance Rv1 and Rv2 have the same value. It is also used to program the connection between the external sensors.

| Bits  | Name  | Content   |
|---|---|---|
| <b>#13 - Reserved</b>   |   |   |
| 15:0  | Reserved                                      | Must be filled with 0x0000  |
| <b>#14 – Programmable resistance trimming configuration word (Common for all sensors)</b> |   |   |
| 5:0   | Sensor_Res_Trim                               | Trimming of the programmable resistances Rv1 and Rv2:<br>Bits[5-0]=0 : the serial resistance is 0.5kΩ<br>Bit[0]=1 → add 1kΩ to the serial resistance<br>Bit[1]=1 → add 2kΩ to the serial resistance<br>Bit[2]=1 → add 4kΩ to the serial resistance<br>Bit[3]=1 → add 8kΩ to the serial resistance<br>Bit[4]=1 → add 16kΩ to the serial resistance<br>Bit[5]=1 → add 32kΩ to the serial resistance |
| 9:6   | Melexis calibration: do not change this value |   |
| 15:10   | Reserved                                      | Must be filled with 0x0000  |

### 9.2.3. Sensor specific configuration

The following registers configure the sensor acquisition chain. This configuration is sensor specific.

**Sensor control word** (EEPROM & Register, address #15. EEPROM only, addresses #1B, #21)

| Bits                               | Name                     | Description (when =1)  |
|------------------------------------|--------------------------|--|
| <b>#15 - Sensor control word</b>   |                          |  |
| 15:14                              | <b>ADC_Mode</b>          | <b>ADC mode</b><br>00: higher speed, but lower accuracy<br>01, 10: intermediate modes<br>11: lower speed, but higher accuracy  |
| 13:12                              | <b>Sensor0_InitTime</b>  | <b>Sensor initialization time</b><br>00: 330µs (= default initialization time for the internal sensor)<br>01: 2.9ms<br>10: 17ms<br>11: 128ms<br><br>Reserved (00)  |
| 11                                 |                          | <b>Interrupt conditions control</b><br>- generate an interrupt when the last sample is above the programmed high threshold   |
| 10                                 | <b>Sensor0_Irq_Above</b> | - generate an interrupt when the last sample is between the programmed high and low thresholds   |
| 9                                  | <b>Sensor0_Irq_Betwn</b> | - generate an interrupt when the last calculated sample is below the programmed low threshold  |
| 8                                  | <b>Sensor0_Irq_Below</b> |  |
| 7                                  | <b>ADC_LowPower</b>      | <b>Low power mode.</b> Enable the low power mode of the ADC.   |
| 6                                  | <b>ADC_DataLogAbove</b>  | <b>Data logging control</b><br>- store the calculated samples* above the high threshold<br>- store the calculated samples* between the high and low thresholds<br>- store the calculated samples* below the low threshold<br><br>* ADC value compared without prefix |
| 5                                  | <b>ADC_DataLogBetwn</b>  |  |
| 4                                  | <b>ADC_DataLogBelow</b>  |  |
| 3:2                                |                          | Reserved (00)  |
| 1:0                                | <b>ADC_Proc_Ctrl</b>     | <b>Samples processing control</b><br>Defines the rules for the calculation of the value which will be stored in the <i>ADC buffer</i><br>00 - single sample<br>01 - average of 2 samples<br>10 - average of 8 samples<br>11 - average of 32 samples                  |
| <b>#1B - Sensor 1 control word</b> |                          |  |
| 15:0                               | Same as above            | Same as above  |
| <b>#21 - Sensor 2 control word</b> |                          |  |
| 15:0                               | Same as above            | Same as above  |



**Sensor thresholds** (EEPROM & Register, addresses #16 and #17. EEPROM only #1C, #1D and #22, #23)

| Bits                                 | Name                     | Description                  |
|--------------------------------------|--------------------------|------------------------------|
| <b>#16 - Sensor 0 low threshold</b>  |                          |                              |
| 15:0                                 | <b>Sensor0_ThresLow</b>  | Sensor 0 low threshold word  |
| <b>#17 - Sensor 0 high threshold</b> |                          |                              |
| 15:0                                 | <b>Sensor0_ThresHigh</b> | Sensor 0 high threshold word |
| <b>#1C – Sensor 1 low threshold</b>  |                          |                              |
| 15:0                                 | <b>Sensor1_ThresLow</b>  | Sensor 1 low threshold word  |
| <b>#1D – Sensor 1 high threshold</b> |                          |                              |
| 15:0                                 | <b>Sensor1_ThresHigh</b> | Sensor 1 high threshold word |
| <b>#22 – Sensor 2 low threshold</b>  |                          |                              |
| 15:0                                 | <b>Sensor2_ThresLow</b>  | Sensor 2 low threshold word  |
| <b>#23 – Sensor 2 high threshold</b> |                          |                              |
| 15:0                                 | <b>Sensor2_ThresHigh</b> | Sensor 2 high threshold word |

**Signal Conditioner words** (EEPROM & Register, addresses #18. EEPROM only #1E and #24)

The MLX90129 can handle 2 different external sensors and 1 internal sensor. Each of these sensor output signals can be conditioned in a different way, using different values of gains and DC levels (offset). The chopper option can be used to get rid of the internal offset of the programmable amplifiers. It is effective only when the averaging option of ADC is used. The chopper enable makes the ADC conversion longer.

| Bits   | Name                      | Content  |
|--|---------------------------|--|
| <b>#18 - Sensor 0: Signal Conditioner configuration word</b> |                           |  |
| 7:0  | <b>Sensor0_DacCode</b>    | DAC code, for Sensor0 (offset or level shifter):<br>00000000: 0<br>01111111: Vref/2<br>10000000: 0<br>11111111: -Vref/2  |
| 11:8   | <b>Sensor0_Pga1Gain</b>   | Gain of PGA1: 0000: Gain=8<br>0001: Gain=10<br>0010: Gain=12.6<br>0011: Gain=15.5<br>0100: Gain=19.6<br>0101: Gain=24.5<br>0110: Gain=30.8<br>0111: Gain=38.1<br>1000: Gain=47.6<br>1001: Gain=59.4<br>1010 to 1111: Gain=75 |
| 14:12  | <b>Sensor0_Pga2Gain</b>   | Gain of PGA2: 000: Gain=1<br>001: Gain=2<br>010: Gain=3<br>011: Gain=4<br>100: Gain=5<br>101: Gain=6<br>110: Gain=7<br>111: Gain=8   |
| 15   | <b>Sensor0_Chopper_En</b> | Chopper enable 1: enabled  |
| <b>#1E - Sensor 1: Signal Conditioner configuration word</b> |                           |  |
| 15:0   | Same as above             | Same as above  |
| <b>#24 - Sensor 2: Signal Conditioner configuration word</b> |                           |  |

|      |               |               |
|------|---------------|---------------|
| 15:0 | Same as above | Same as above |
|------|---------------|---------------|

**Sensor connection words** (EEPROM & Register, addresses #19. EEPROM only #1F and #25)

The first amplifier (PGA1) of the conditioning chain may be connected to the internal / external sensors in some different ways. Each sensor has its own connections, programmed in the following EEPROM words:

| Bits  | Name                         | Content  |
|---|------------------------------|--|
| <b>#19 - Sensor 0: Connections configuration word</b> |                              |  |
| 9:0   | <b>Sensor0_MuxCfg</b>        | Input multiplexer selection bits<br>(connecting the multiplexer inputs to the first amplifier PGA1)<br>Bit[0] = 0 → Mux out1= SENS1 (default)<br>Bit[1] = 1 → Mux out1= SENS3<br>Bit[2] (not used = 0)<br>Bit[3] = 1 → Mux out1= VCM (=VREF/2)<br>Bit[4] = 1 → Mux out1=Temp. sensor output1<br>Bit[5] = 0 → Mux out2= SENS2 (default)<br>Bit[6] = 1 → Mux out2= SENS4<br>Bit[7] = 1 → Mux out2= SENS5<br>Bit[8] = 1 → Mux out2= VCM (=VREF/2)<br>Bit[9] = 1 → Mux out2=Temp. sensor output2 |
| 12:10   | Reserved, <b>Must be 000</b> |  |
| 15:13   | <b>Power_Check</b>           | '111' = power check enable   |
| <b>#1F - Sensor 1: Connections configuration word</b> |                              |  |
| 9:0   | <b>Sensor1_MuxCfg</b>        | Same as above  |
| <b>#25 - Sensor 2: Connections configuration word</b> |                              |  |
| 9:0   | <b>Sensor2_MuxCfg</b>        | Same as above  |

**Sensor serial resistance conditioner words** (EEPROM & Register, addresses #1A. EEPROM only #20 and #26)

Each of the 3 sensors called Sensor0, Sensor1, and Sensor2 can be connected to some serial resistances in order to reduce their current consumption, or to set their common-mode level.

| Bits   | Name                   | Content  |
|--|------------------------|--|
| <b>#1A</b> - Sensor 0 serial resistance configuration word |                        |  |
| 15   | <b>Sensor0_Temp_En</b> | Bit[15]=1 -> enables the temperature sensor  |
| 14:0   | <b>Sensor0_Res_Cfg</b> | Resistance network configuration:<br>Bit[0] (not used=0)<br>Bit[1]=1 → SENSSUP2 = VREF<br>Bit[2]=1 → SENS3 = VREF<br>Bit[3] (not used=0)<br>Bit[4]=1 → SENSSUP2 = VSS<br>Bit[5]=1 → SENS4 = VSS<br>Bit[6]=1 → VCM = VREF/2 (enabled)<br>Bit[7]=1 → connects programmable resistance 1 to VREF<br>Bit[8]=1 → connects programmable resistance 2 to VSS<br>Bit[9] (not used=0)<br>Bit[10]=1 → connects programmable resistance 1 to SENSSUP2<br>Bit[11]=1 → connects programmable resistance 1 to SENS3<br>Bit[12] (not used=0)<br>Bit[13]=1 → connects programmable resistance 2 to SENSSUP2<br>Bit[14]=1 → connects programmable resistance 2 to SENS4 |
| <b>#20</b> - Sensor 1 serial resistance configuration word |                        |  |
| 15:0   | Same as above          | Same as above  |
| <b>#26</b> - Sensor 2 serial resistance configuration word |                        |  |
| 15:0   | Same as above          | Same as above  |

### 9.3. Power management

The power management unit controls the following features of the MLX90129:

- Start-up modes (with or without battery)
- Power modes (stand-by, sleep, watchful or run mode)
- Energy scavenging for battery-less applications
- Oscillators management (digital clock, wake-up timer)

#### 9.3.1. Power modes

##### Power-off mode

No battery, no field. The MLX90129 can quit this mode when a battery is connected or when a RF field is applied.

##### Watchful mode

This mode is the initial state, after power-on. In this state, the digital part is activated; the MLX90129 can receive commands from the RFID or SPI.

##### Run mode

Depending on the command from SPI or RFID, or on request from DMA, the MLX90129 enters the Run mode, where all the blocks implied in the transaction are powered. This state is not low-power, but time-limited.

##### Stand-by mode

In the stand-by mode, the supply voltage is applied, but the MLX90129 consumes a minimum current. Typically, this mode is used after the module has been assembled and tested. Then, it can be stored for a long time without wasting the battery energy.

The Digital Controller can not exit this mode by itself. It can only exit it by an external interrupt: emission of a RFID field or asserting low the Slave Select input of the SPI (during a specified time)

The MLX90129 may re-enter this mode upon request from SPI or RFID (in writing the Wake-up Timer configuration word). It is possible to enter this mode after a programmed count-down from the Wake-up timer, or after a logging sequence.

##### Sleep mode

In the *Sleep mode*, only the wake-up timer works and sends an IRQ pulse (Interrupt Request) to the microcontroller after a programmable time period. The MLX90129 may leave this mode in the following cases:

- \_ emission of a RFID field
- \_ asserting low the Slave Select input of the SPI (during a specified time)
- \_ DMA request to run an acquisition after a defined time period.

In the sleep and the stand-by modes, it is possible to power-down the external device supplied by VREG.

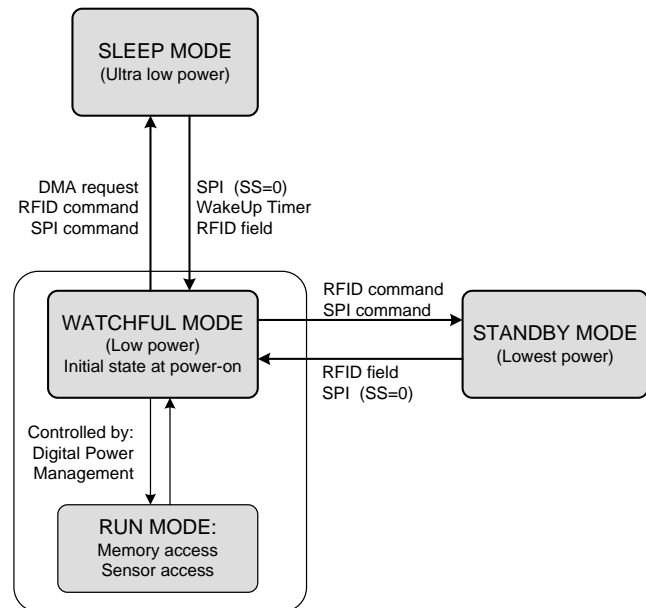

### 9.3.2. Oscillators management

The MLX90129 can use 3 clock sources from:

- An internal 5MHz RC-oscillator for the digital clock
- An internal low-power low-frequency RC-oscillator (used as a wake-up timer)
- An external low-power low-frequency quartz oscillator (used for accurate wake-up timer)

The use of the quartz oscillator is optional. If it is chosen instead of the RC-oscillator, then a 32.768kHz crystal should be connected between the pads XIN and XOUT.

### 9.3.3. Energy scavenging

The MLX90129 embeds power supply management capabilities which allow a strong flexibility to design data logger devices with strong power consumption constraints. It is possible to store the energy from the incoming magnetic field into an external capacitor, on pad VFIELD or to run from a coin cell battery.

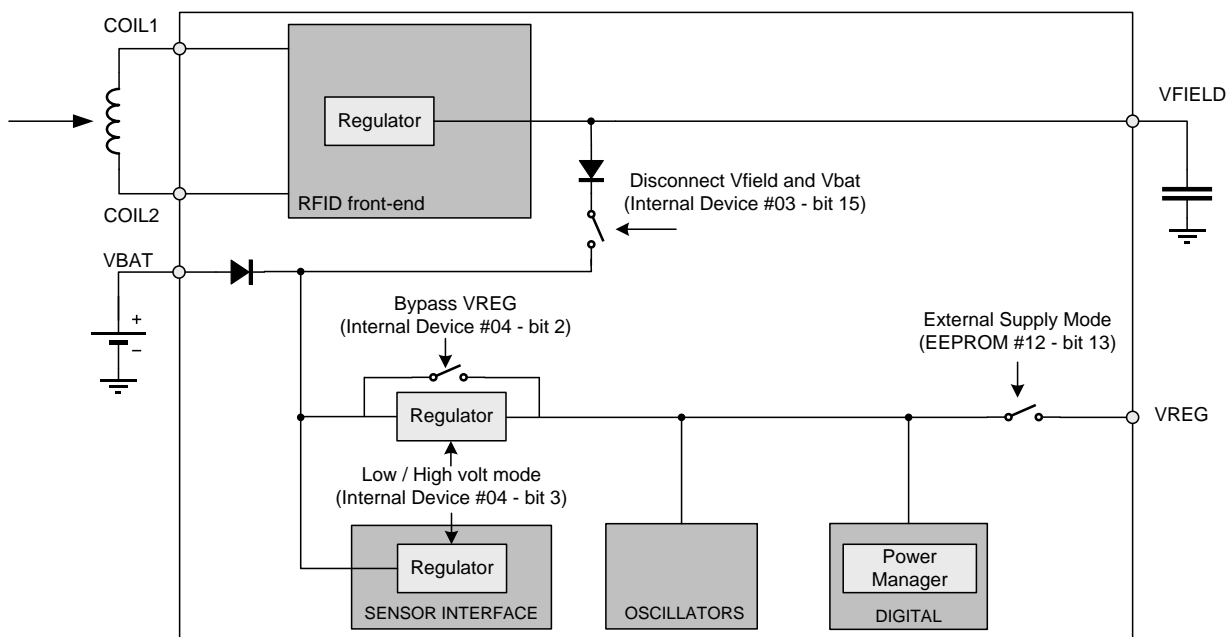

The power management mode is defined by several switches configurable through the EEPROM and EE-Latch.

- For the battery-less applications, VFIELD pad can be used to supply the MLX90129 if the switch between VFIELD and VBAT is closed (default).
- For battery applications, the switch between VFIELD and VBAT could be open
- For both kind of application, it is possible to supply the external device (external SPI memory or microcontroller) via VREG. The supply can be either at any time, or only in watchful state depending the *External Supply Mode* switch configuration
- The Regulator which supplies VREG can be bypassed using the switch *Bypass VREG*. The output voltage on VREG is short cuts with Vbat and Vfield.
- The VREG and SENSOR (Vref) regulators can be configured in high or low volt mode.

The commands of these switches are defined as:

*Disconnect Vfield Vbat* = Internal Device #03, bit 15

*Bypass VREG* = Internal Device #04, bit 2

*External Supply Mode* = EEPROM #12, bit 13

*High or Low volt mode* = Internal Device #04, bit 3

## 9.4. Security

### 9.4.1. Communication security

The *Device Security Register* is stored in the EEPROM. It contains the access rights to the different memories by the RFID interface. It allows a partial or complete disabling of the RFID interface. In addition, it controls the functionality of the SPI by making it master or slave.

**Device security map** configuration register (EEPROM & Register, address #05, Read/Write)

| Bits                             | Name            | Description (when bit = 1)  |
|----------------------------------|-----------------|---|
| <b>#05 - Device security map</b> |                 |   |
| 15:14                            | -               | Reserved (must be 00)   |
| 13                               | Rfid_Page0Read  | Allow read access to Register file page 0 for RFID.                     |
| 12                               | Rfid_Page0Write | Allow write access to Register file page 0 for RFID.*                   |
| 11                               | Rfid_EEpViaDma  | Allows RFID access to internal EEPROM via DMA.                          |
| 10                               | Rfid_Adc_Access | Allow access to ADC buffer for RFID                                     |
| 9                                | Rfid_Int_Read   | Allow a read access to the external memory by RFID                      |
| 8                                | Rfid_Int_Write  | Allow a read & write access to the external memory by RFID *            |
| 7                                | Rfid_EE_Read    | Allow a read access to EE-Latches by RFID                               |
| 6                                | Rfid_EE_Write   | Allow a read & write access to EE-Latches by RFID *                     |
| 5                                | Rfid_Reg_Read   | Allow a read access to the Register file page 1 by RFID                 |
| 4                                | Rfid_Reg_Write  | Allow a read & write access to the Register file page 1 by RFID *       |
| 3                                | Rfid_Lock_Dis   | Disable the RFID Core-lock access function                              |
| 2                                | Rfid_LockUn_En  | Disable RFID lock device / unlock device functionality**                |
| 1                                | Rfid_Dis        | Disable the RFID communication media                                    |
| 0                                | Spi_Master      | SPI slave disable. Disable SPI-slave and enable activity of SPI-master. |

\*note: if the write-access is allowed, the read-access is also allowed, independently of the value of the *read access* bit

\*\* when disabled the MLX90129 does not answer to the command "LOCK DEVICE"

### 9.4.2. EEPROM Access security

The access to the EEPROM words is protected depending on their content. Three security levels have been defined and can be chosen for any EEPROM page. If any external device tries to access via SPI a memory location without permission, it obtains value 0xFFFF as result. Via RFID, the error response is defined by the standard ISO15693.

- Definition of the different security levels

| Security level | Code | Write access   | Read access    | Typical application  |
|----------------|------|----------------|----------------|--|
| L0             | 00   | SPI, DMA       | SPI, DMA       | UID and security configuration   |
| L1             | 01   | SPI, DMA       | SPI, RFID, DMA |  |
| L2             | 10   | SPI, RFID, DMA | SPI, RFID, DMA | Register file initial configuration, data logging<br>Customer ID, Unlocked User Data |
| L3             | 11   | Reserved       | Reserved       |  |

- EEPROM security access levels

The user data are separated in 8 pages, whose access levels (L0 to L3) are defined thanks to 2 bits, stored in the 'Security Map Register' of the EEPROM. A security procedure based on a password is required to execute the unlocking. The password is stored in EEPROM #06.

#### EEPROM security map

| Page | Address (hex) | Access level | Words | Description                            |
|------|---------------|--------------|-------|--|
| 0    | 0x00 - 0x08   | L0           | 9     | Page 0: Melexis ID and device security |
| 1    | 0x09 - 0x26   | programmable | 30    | Page 1: Register file initial image    |
| 2    | 0x27 - 0x3F   | programmable | 25    | Page 2: User defined data, backup      |
| 3    | 0x40 - 0x5F   | programmable | 32    | Page 3: User defined data              |
| 4    | 0x60 - 0x7F   | programmable | 32    | Page 4: User defined data              |
| 5    | 0x80 - 0x9F   | programmable | 32    | Page 5: User defined data              |
| 6    | 0xA0 - 0xBF   | programmable | 32    | Page 6: User defined data              |
| 7    | 0xC0 - 0xFF   | programmable | 64    | Page 7: User defined data              |

#### EEPROM security map register (EEPROM, address #04)

| Bits (security level) | Description                    |
|-----------------------|--------------------------------|
| [15:14]               | Access level for EEPROM Page 7 |
| [13:12]               | Access level for EEPROM Page 6 |
| [11:10]               | Access level for EEPROM Page 5 |
| [ 9 : 8]              | Access level for EEPROM Page 4 |
| [ 7 : 6]              | Access level for EEPROM Page 3 |
| [ 5 : 4]              | Access level for EEPROM Page 2 |
| [ 3 : 2]              | Access level for EEPROM Page 1 |
| [ 1 : 0]              | Reserved (must be 0x00)        |

## 10. Application Information

### 1. RFID temperature sensor tag

The MLX90129 may be used as a 13.56 MHz sensor transponder. The LC antenna is easy to implement and to tune thanks to the integrated programmable capacitance. The internal sensor allows monitoring the temperature without external component.

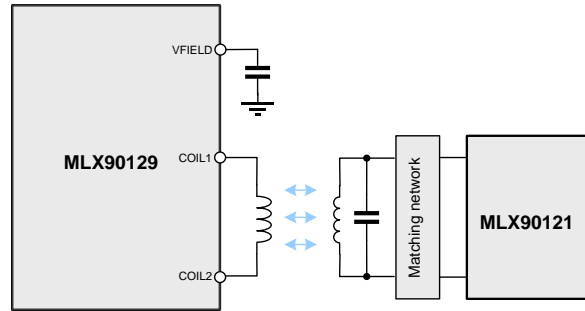

### 2. RFID multi sensors tag

Thanks to the multi sensor interface of the MLX90129, two differential sensors can be added. In this configuration 3 sensor values can be read by RFID.

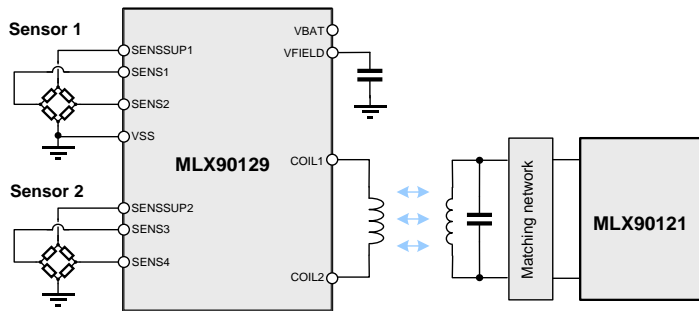

### 3. Data logger

The MLX90129 may be used in a standalone way as a data logger. The data may be stored in the internal EEPROM or in an external serial SPI EEPROM. Using the *automatic logging mode*, the MLX90129 wakes-up each programmed time period, converts the sensor data and stores it in the selected memory. This process may be hold or stopped by an external SPI master (microcontroller,...) or a RFID base-station. The data stored in EEPROM may be read via RFID.

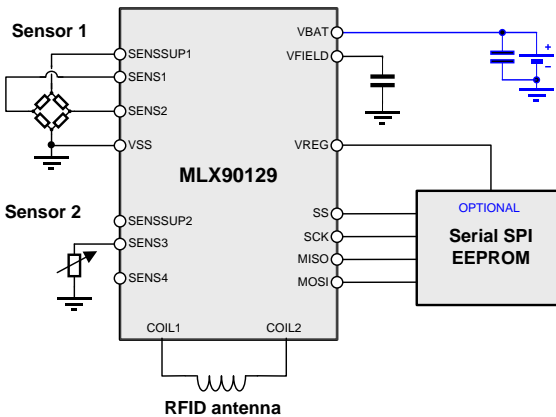



**4. Micro-controller based applications**

Numerous flexible applications using a microcontroller can be imagined. The microcontroller may manage the MLX90129 to sense, store or send the data via RFID. It may also control a RF transceiver as the TH7122 and an external non-volatile memory or a LCD.

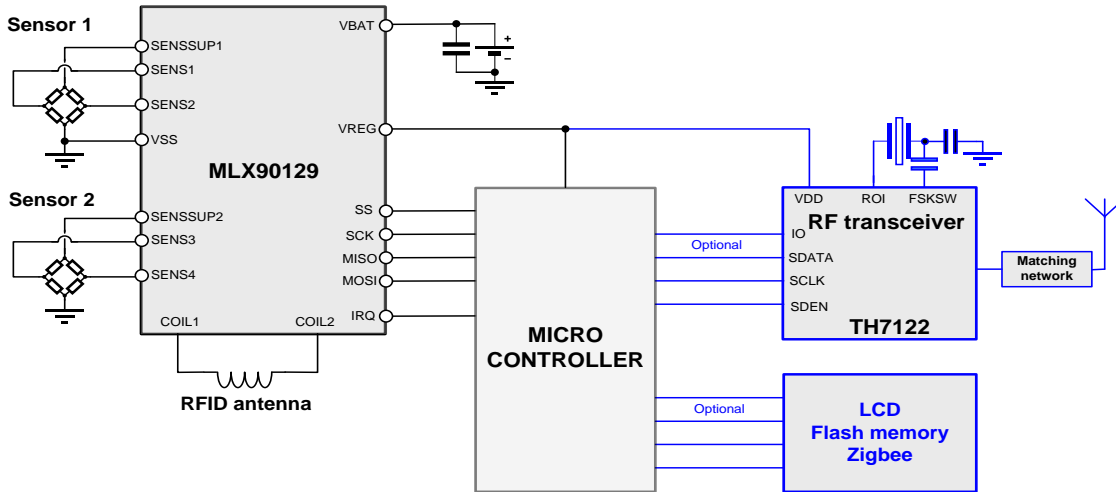

**5. Padlock application**

When the event detection system is enabled, a padlock may be made with a wire connected between the pins AT and VSS. If this wire is broken, this event is memorized, and an interrupt can (optionally) be sent to the external microcontroller. Instead of the wire, a light sensor (solar cell) may be connected. When powered, it sets an IRQ to the controller.

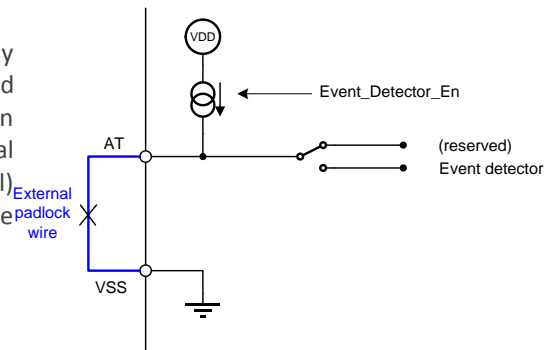

**6. Serial resistor connected to the external sensor(s)**

Numerous connections are possible between the external sensor and the internal resistors. The following figure shows an example of these possibilities.

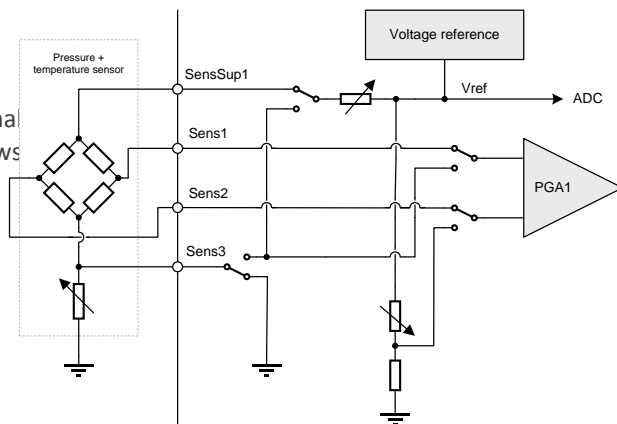

## 11. Reliability Information

Standard information regarding manufacturability of Melexis products with different soldering processes

Our products are classified and qualified regarding soldering technology, solderability and moisture sensitivity level according to following test methods:

### Reflow Soldering SMD's (Surface Mount Device)s

- IPC/JEDEC J-STD-020  
Moisture/Reflow Sensitivity Classification for Nonhermetic Solid State Surface Mount Devices (classification reflow profiles according to table 5-2)
- EIA/JEDEC JESD22-A113  
Preconditioning of Nonhermetic Surface Mount Devices Prior to Reliability Testing (reflow profiles according to table 2)

### Wave Soldering SMD's (Surface Mount Device)s and THD's (Through Hole Device)s

- EN60749-20  
Resistance of plastic- encapsulated SMD's to combined effect of moisture and soldering heat
- EIA/JEDEC JESD22-B106 and EN60749-15  
Resistance to soldering temperature for through-hole mounted devices

### Iron Soldering THD's (Through Hole Device)s

- EN60749-15  
Resistance to soldering temperature for through-hole mounted devices

### Solderability SMD's (Surface Mount Device)s and THD's (Through Hole Device)s

- EIA/JEDEC JESD22-B102 and EN60749-21  
Solderability

For all soldering technologies deviating from above mentioned standard conditions (regarding peak temperature, temperature gradient, temperature profile etc) additional classification and qualification tests have to be agreed upon with Melexis.

The application of Wave Soldering for SMD's is allowed only after consulting Melexis regarding assurance of adhesive strength between device and board.

Melexis is contributing to global environmental conservation by PROMoting **lead free** solutions. For more information on qualifications of **RoHS** compliant products (RoHS = European directive on the Restriction Of the use of certain Hazardous Substances) please visit the quality page on our website: <http://www.melexis.com/quality.aspx>.

## 12. ESD Precautions

Electronic semiconductor products are sensitive to Electro Static Discharge (ESD).

Always observe Electro Static Discharge control procedures whenever handling semiconductor products.

### 13. Package Information

TSSOP20:

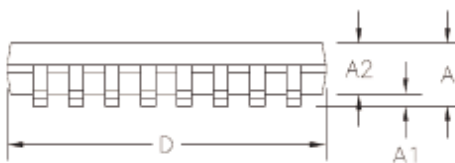
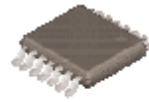
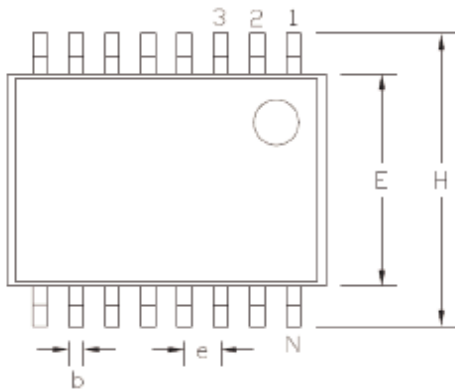

This table in mm

| N  |     | A    | A1   | A2   | D    | E    | H    | L    | b    | c    | e    | $\alpha$ |
|----|-----|------|------|------|------|------|------|------|------|------|------|----------|
| 8  | min | –    | 0.05 | 0.85 | 2.90 | 4.30 | 6.40 | 0.50 | 0.19 | 0.09 | 0.65 | 0°       |
|    | max | 1.10 | 0.15 | 0.95 | 3.10 | 4.50 | BSC  | 0.75 | 0.30 | 0.20 | BSC  | 8°       |
| 14 | min | –    | 0.05 | 0.85 | 4.90 | 4.30 | 6.40 | 0.50 | 0.19 | 0.09 | 0.65 | 0°       |
|    | max | 1.10 | 0.15 | 0.95 | 5.10 | 4.50 | BSC  | 0.75 | 0.30 | 0.20 | BSC  | 8°       |
| 16 | min | –    | 0.05 | 0.85 | 4.90 | 4.30 | 6.40 | 0.50 | 0.19 | 0.09 | 0.65 | 0°       |
|    | max | 1.10 | 0.15 | 0.95 | 5.10 | 4.50 | BSC  | 0.75 | 0.30 | 0.20 | BSC  | 8°       |
| 20 | min | –    | 0.05 | 0.85 | 6.40 | 4.30 | 6.40 | 0.50 | 0.19 | 0.09 | 0.65 | 0°       |
|    | max | 1.10 | 0.15 | 0.95 | 6.60 | 4.50 | BSC  | 0.75 | 0.30 | 0.20 | BSC  | 8°       |
| 24 | min | –    | 0.05 | 0.85 | 7.70 | 4.30 | 6.40 | 0.50 | 0.19 | 0.09 | 0.65 | 0°       |
|    | max | 1.10 | 0.15 | 0.95 | 7.90 | 4.50 | BSC  | 0.75 | 0.30 | 0.20 | BSC  | 8°       |
| 28 | min | –    | 0.05 | 0.85 | 9.60 | 4.30 | 6.40 | 0.50 | 0.19 | 0.09 | 0.65 | 0°       |
|    | max | 1.10 | 0.15 | 0.95 | 9.80 | 4.50 | BSC  | 0.75 | 0.30 | 0.20 | BSC  | 8°       |

## 14. Contact

For the latest version of this document, go to our website at [www.melexis.com](http://www.melexis.com).

For additional information, please contact our Direct Sales team and get help for your specific needs:

|                |                                  |
|----------------|----------------------------------|
| Europe, Africa | Telephone: +32 13 67 04 95       |
|                | Email : sales_europe@melexis.com |
| Americas       | Telephone: +1 603 223 2362       |
|                | Email : sales_usa@melexis.com    |
| Asia           | Email : sales_asia@melexis.com   |

## 15. Disclaimer

*The information furnished by Melexis herein ("Information") is believed to be correct and accurate. Melexis disclaims (i) any and all liability in connection with or arising out of the furnishing, performance or use of the technical data or use of the product(s) as described herein ("Product") (ii) any and all liability, including without limitation, special, consequential or incidental damages, and (iii) any and all warranties, express, statutory, implied, or by description, including warranties of fitness for particular purpose, non-infringement and merchantability. No obligation or liability shall arise or flow out of Melexis' rendering of technical or other services.*

*The Information is provided "as is" and Melexis reserves the right to change the Information at any time and without notice. Therefore, before placing orders and/or prior to designing the Product into a system, users or any third party should obtain the latest version of the relevant information to verify that the information being relied upon is current.*

*Users or any third party must further determine the suitability of the Product for its application, including the level of reliability required and determine whether it is fit for a particular purpose.*

*The Information is proprietary and/or confidential information of Melexis and the use thereof or anything described by the Information does not grant, explicitly or implicitly, to any party any patent rights, licenses, or any other intellectual property rights.*

*This document as well as the Product(s) may be subject to export control regulations. Please be aware that export might require a prior authorization from competent authorities.*

*The Product(s) are intended for use in normal commercial applications. Unless otherwise agreed upon in writing, the Product(s) are not designed, authorized or warranted to be suitable in applications requiring extended temperature range and/or unusual environmental requirements. High reliability applications, such as medical life-support or life-sustaining equipment are specifically not recommended by Melexis.*

*The Product(s) may not be used for the following applications subject to export control regulations: the development, production, processing, operation, maintenance, storage, recognition or proliferation of 1) chemical, biological or nuclear weapons, or for the development, production, maintenance or storage of missiles for such weapons; 2) civil firearms, including spare parts or ammunition for such arms; 3) defense related products, or other material for military use or for law enforcement; 4) any applications that, alone or in combination with other goods, substances or organisms could cause serious harm to persons or goods and that can be used as a means of violence in an armed conflict or any similar violent situation.*

*The Products sold by Melexis are subject to the terms and conditions as specified in the Terms of Sale, which can be found at <https://www.melexis.com/en/legal/terms-and-conditions>.*

*This document supersedes and replaces all prior information regarding the Product(s) and/or previous versions of this document.*

*Melexis NV © - No part of this document may be reproduced without the prior written consent of Melexis. (2016)*

*ISO/TS 16949 and ISO14001 Certified*