

**SCHOTTKY BARRIER RECTIFIER**

**FEATURES**

- Low power loss, high efficiency
- High reliability
- High Conductance

**MARKING:**

MMBD5817A	MMBD5817C	MMBD5817S
<b>MARKING:7A</b>	<b>MARKING:7C</b>	<b>MARKING:7S</b>

**SOT-23**

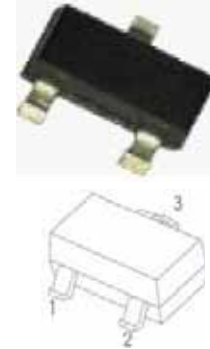

**MAXIMUM RATINGS** (@ TA=25 °C unless otherwise noted)

RATINGS	SYMBOL	MMBD5817A/C/S	UNITS
Maximum Recurrent Peak Reverse Voltage	V <sub>RRM</sub>	20	Volts
Maximum RMS Voltage	V <sub>RMS</sub>	14	Volts
Maximum DC Blocking Voltage	V <sub>DC</sub>	20	Volts
Maximum Average Forward Rectified Current .375" (9.5mm) lead length at T <sub>L</sub> =90°C	I <sub>O</sub>	0.4	Amps
Peak Forward Surge Current 8.3 ms single half sine-wave superimposed on rated load (JEDEC method)	I <sub>FSM</sub>	2	Amps
Typical Current Squared Time	I <sup>2</sup> T	0.0166	A <sup>2</sup> S
Typical Thermal Resistance (Note 3)	R <sub>θJA</sub>	444	°C/W
Typical Total Capacitance(Note 1)	C <sub>T</sub>	120	pF
Operating Temperature Range	T <sub>J</sub>	-55 to + 150	°C
Storage Temperature Range	T <sub>STG</sub>	-55 to + 150	°C

**ELECTRICAL CHARACTERISTICS**(@TA=25 °C unless otherwise noted)

CHARACTERISTICS	SYMBOL	MMBD5817A/C/S	UNITS
Maximum Instantaneous Forward Voltage	@I <sub>F</sub> =0.1A	.31	Volts
	@I <sub>F</sub> =0.5A	.43	
Maximum Average Reverse Current at Rated DC Blocking Voltage	@T <sub>A</sub> = 25°C	250	uAmps
	@T <sub>A</sub> = 150°C	10	mAmps

- NOTES : 1. Measured at 1 MHz and applied reverse voltage of 4.0 volts.  
2. "ROHS compliant".  
3. Thermal Resistance : At 9.5mm lead lengths, PCB mounted.

# RATING AND CHARACTERISTICS CURVES ( MMBD5817A/C/S)

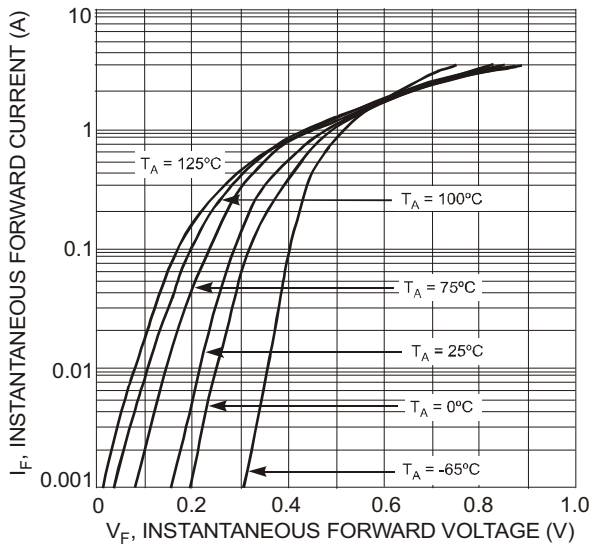

Fig. 1 Typical Forward Characteristics, Per Element

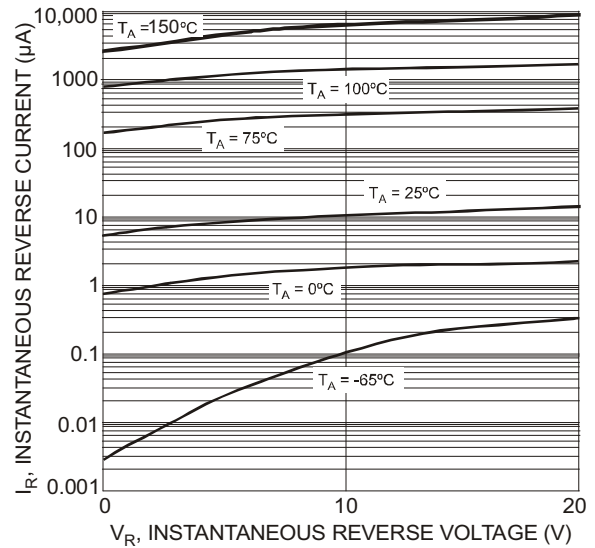

Fig. 2 Typical Reverse Characteristics, Per Element

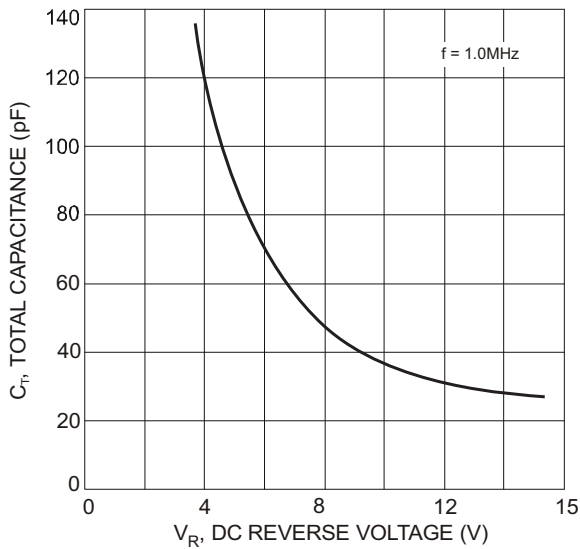

Fig. 3 Total Capacitance vs. Reverse Voltage, Per Element

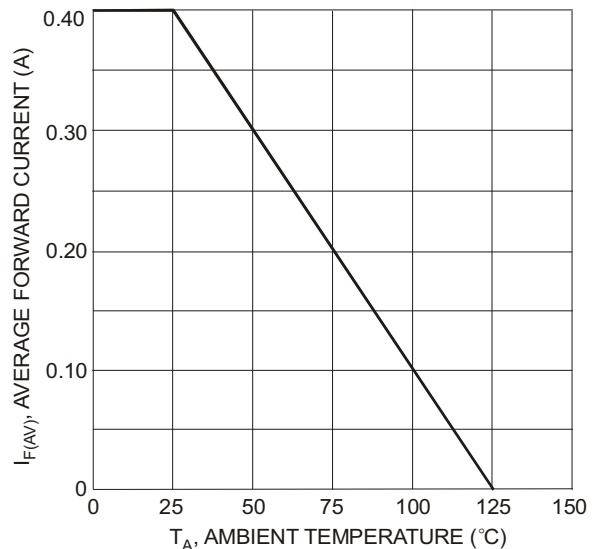
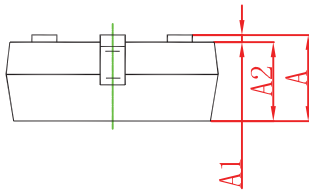
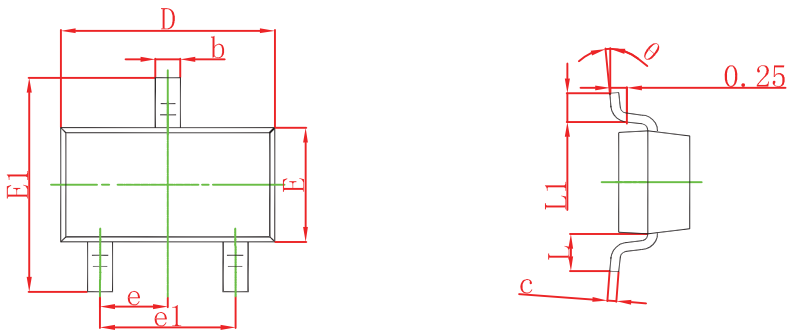

Fig. 4 Forward Current Derating Curve, Per Element

## SOT-23 Package Outline Dimensions



Symbol	Dimensions In Millimeters		Dimensions In Inches	
	Min	Max	Min	Max
A	0.900	1.150	0.035	0.045
A1	0.000	0.100	0.000	0.004
A2	0.900	1.050	0.035	0.041
b	0.300	0.500	0.012	0.020
c	0.080	0.150	0.003	0.006
D	2.800	3.000	0.110	0.118
E	1.200	1.400	0.047	0.055
E1	2.250	2.550	0.089	0.100
e	0.950 TYP		0.037 TYP	
e1	1.800	2.000	0.071	0.079
L	0.550 REF		0.022 REF	
L1	0.300	0.500	0.012	0.020
θ	0°	8°	0°	8°

## SOT-23 Suggested Pad Layout

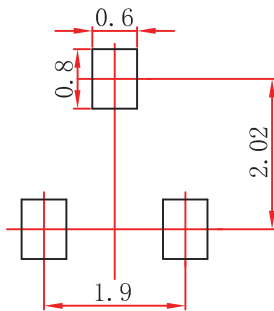

**Note:**

1. Controlling dimension; in millimeters.
2. General tolerance:  $\pm 0.05$  mm.
3. The pad layout is for reference purposes only.

# SOT-23 Tape and Reel

## SOT-23 Embossed Carrier Tape

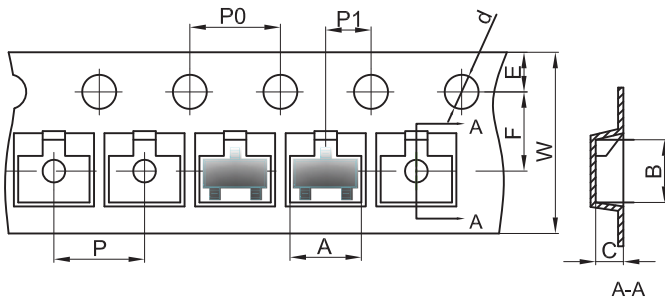

**Packaging Description:**  
 SOT-23 parts are shipped in tape. The carrier tape is made from a dissipative (carbon filled) polycarbonate resin. The cover tape is a multilayer film (Heat Activated Adhesive in nature) primarily composed of polyester film, adhesive layer, sealant, and anti-static sprayed agent. These reeled parts in standard option are shipped with 3,000 units per 7" or 17.8cm diameter reel. The reels are clear in color and is made of polystyrene plastic (anti-static coated).

Dimensions are in millimeter										
Pkg type	A	B	C	d	E	F	P0	P	P1	W
SOT-23	3.15	2.77	1.22	Ø1.50	1.75	3.50	4.00	4.00	2.00	8.00

## SOT-23 Tape Leader and Trailer

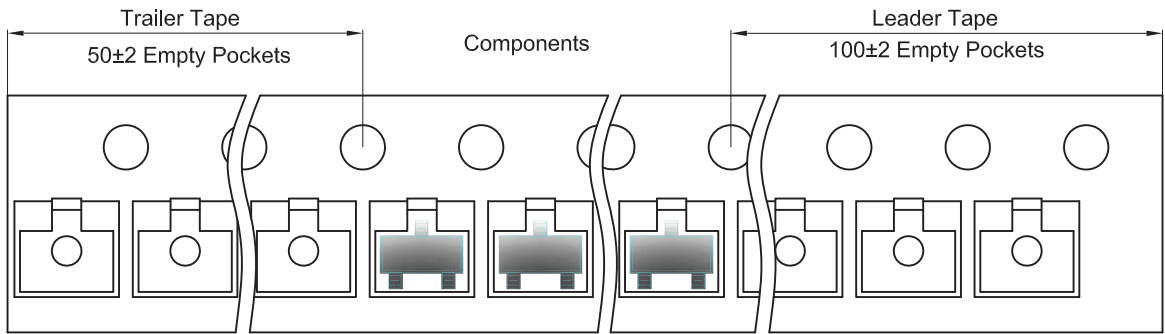

## SOT-23 Reel

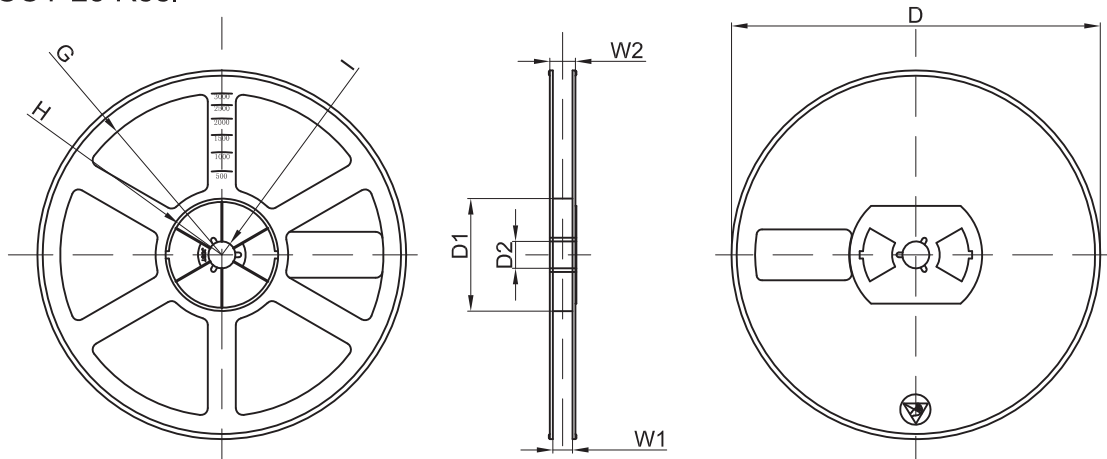

Dimensions are in millimeter								
Reel Option	D	D1	D2	G	H	I	W1	W2
7" Dia	Ø178.00	54.40	13.00	R78.00	R25.60	R6.50	9.50	12.30

REEL	Reel Size	Box	Box Size(mm)	Carton	Carton Size(mm)	G.W.(kg)
3000 pcs	7 inch	45,000 pcs	203×203×195	180,000 pcs	438×438×220	

## DISCLAIMER NOTICE

Rectron Inc reserves the right to make changes without notice to any product specification herein, to make corrections, modifications, enhancements or other changes. Rectron Inc or anyone on its behalf assumes no responsibility or liability for any errors or inaccuracies. Data sheet specifications and its information contained are intended to provide a product description only. "Typical" parameters which may be included on RECTRON data sheets and/ or specifications can and do vary in different applications and actual performance may vary over time. Rectron Inc does not assume any liability arising out of the application or use of any product or circuit.

Rectron products are not designed, intended or authorized for use in medical, life-saving implant or other applications intended for life-sustaining or other related applications where a failure or malfunction of component or circuitry may directly or indirectly cause injury or threaten a life without expressed written approval of Rectron Inc. Customers using or selling Rectron components for use in such applications do so at their own risk and shall agree to fully indemnify Rectron Inc and its subsidiaries harmless against all claims, damages and expenditures.