



SLS SEMICONDUCTOR (SHENZHEN) CO.,LTD.

SOT-23 封装半导体晶体管/SOT-23 Plastic-Encapsulate Transistors

MMBT2222A (NPN)

印章/Marking : 1P

用途/Applications :

用于一般放大电路，与 MMBT2907A 互补。

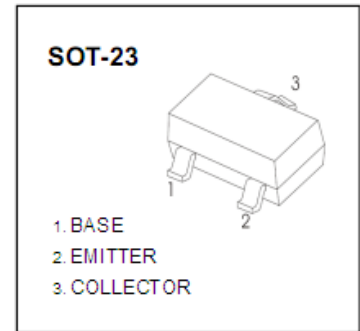

极限参数/Absolute maximum ratings(Ta=25°C)

参数/Parameter	符号/ Symbol	数值/Value	单位/Unit
集电极-基极电压/Collector-Base Voltage	V_{CBO}	75	V
集电极-发射极电压/Collector-Emitter Voltage	V_{CEO}	40	V
发射极-基极电压/Emitter-Base Voltage	V_{EBO}	6	V
集电极连续电流/Collector Current Continuous	I_C	0.6	A
集电极耗散功率/Collector Power Dissipation	P_C	0.25	W
热阻/ Thermal Resistance Junction to Ambient	$R_{\theta JA}$	500	°C/mW
结温/Junction Temperature	T_j	250	°C
储存温度/Storage Temperature	T_{stg}	-55~150	°C

电性能参数/Electrical characteristics (Ta=25°C)

参数	符号	测试条件	最小值	最大值	单位
集电极-基极击穿电压	$V_{BR(CBO)}$	$I_C=10\mu A, I_E=0$	75		V
集电极-发射极击穿电压	$V_{BR(CEO)}$	$I_C=10mA, I_B=0$	40		V
发射极-基极击穿电压	$V_{BR(EBO)}$	$I_E=10\mu A, I_C=0$	6		V
集电极截止电流	I_{CBO}	$V_{CB}=60V, I_E=0$		0.01	μA
发射极截止电流	I_{EBO}	$V_{EB}=3V, I_C=0$		0.1	μA
集电极发射极穿透电流	I_{CEX}	$V_{CE}=30V, V_{BE(off)}=3V$		0.01	μA
直流电流增益	$h_{FE(1)}^*$	$V_{CE}=10V, I_C=150mA$	100	300	
直流电流增益	$h_{FE(2)}^*$	$V_{CE}=10V, I_C=0.1mA$	40		
直流电流增益	$h_{FE(2)}^*$	$V_{CE}=10V, I_C=500mA$	42		
集电极-发射极饱和压降	$V_{CE(sat)}^*$	$I_C=500mA, I_B=50mA$		1	V
集电极-发射极饱和压降	$V_{CE(sat)}^*$	$I_C=150mA, I_B=15mA$		0.3	V
基极-发射极饱和压降	$V_{BE(sat)}^*$	$I_C=500mA, I_B=50mA$		2	V
基极-发射极饱和压降	$V_{BE(sat)}^*$	$I_C=150mA, I_B=15mA$		1.2	V
特征频率	f_T	$V_{CE}=6V, I_C=20mA, f=30MHz$	150		MHz
延迟时间	t_d	$V_{CC}=30V, V_{BE(off)}=-0.5V,$ $I_C=150mA, I_{B1}=15mA$		10	nS
上升时间	t_r			25	nS
存储时间	t_s	$V_{CC}=30V, I_C=150mA,$ $I_{B1}=-I_{B2}=15mA$		225	nS
下降时间	t_f			60	nS

*Pulse test:Pulse Width $\leq 300\mu S$, Duty Circle $\leq 2.0\%$



典型特性曲线图/Typical Characteristics

