

MMSZ5221B THRU MMSZ5267B

List

List..... 1

Package outline..... 2

Features..... 2

Mechanical data..... 2

Maximum ratings 2

Electrical characteristics..... 3

Rating and characteristic curves..... 4~5

Pinning information..... 6

Suggested solder pad layout..... 6

Packing information..... 7

Reel packing..... 8

Suggested thermal profiles for soldering processes..... 8

High reliability test capabilities..... 9

MMSZ5221B THRU MMSZ5267B

500mW Surface Mount
Zener Diodes - 2.4V-75V

Features

- Up to 500mW power dissipation.
- Silicon epitaxial planar chip structure.
- Wide Zener Voltage Range Selection, 2.4V to 75V.
- 5% tolerance of Zener voltage for suffix "B" ex: MMSZ5221B
- Small Package Size for High Density Applications.
- Ideally suited for automated assembly processes.
- We declare that the material of product compliance with RoHS requirements.
- Suffix "-H" indicates Halogen free parts, ex. MMSZ5221B-H.

Mechanical data

- Epoxy: UL94-VO rated flame retardant
- Case : Molded plastic, SOD-123F
- Terminals : Solder plated, solderable per MIL-STD-750, Method 2026
- Polarity : Indicated by cathode band
- Mounting Position : Any
- Weight : Approximated 0.010 gram

Package outline

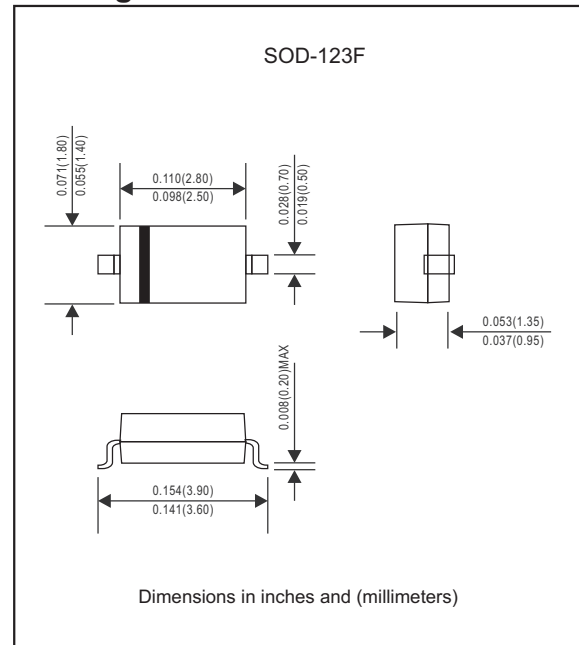

Maximum ratings (at $T_A=25^\circ\text{C}$ unless otherwise noted)

Parameter	Conditions	Symbol	MIN.	TYP.	MAX.	Unit
Forward voltage	$I_F = 10 \text{ mA}$	V_F			0.9	V
Power Dissipation (Note 1)	On FR-5 Board @ $T_L=75^\circ\text{C}$	P_D			500	mW
Thermal Resistance (Note 2)	Junction to ambient	$R_{\theta JA}$		340		$^\circ\text{C/W}$
	Junction to lead	$R_{\theta JL}$		150		$^\circ\text{C/W}$
	Junction to case	$R_{\theta JC}$		200		$^\circ\text{C/W}$
Operating junction temperature range		T_J	-55		+150	$^\circ\text{C}$
Storage temperature range		T_{STG}	-55		+150	$^\circ\text{C}$

1. FR-5 = 3.5 X 1.5 inches, using the minimum recommended footprint.
2. Thermal Resistance measurement obtained via infrared Scan Method.

MMSZ5221B THRU MMSZ5267B

Electrical characteristics (at $T_A=25^\circ\text{C}$ unless otherwise noted)

Part No.	Marking code	Zener voltage			Test current	Zener impedance			Leakage current	
		$V_Z @ I_{ZT}(\text{Volts})$			I_{ZT}	$Z_{ZT} @ I_{ZT}$	$Z_{ZK} @ I_{ZK}$	I_{ZK}	I_R	V_R
		Min	Nom	Max	mA	(Ω)Max	(Ω)Max	mA	(μA)Max	Volts
MMSZ5221B	C1	2.28	2.4	2.52	20.0	30	1200	0.25	100	1.0
MMSZ5222B	C2	2.38	2.5	2.63	20.0	30	1250	0.25	100	1.0
MMSZ5223B	C3	2.57	2.7	2.84	20.0	30	1300	0.25	75	1.0
MMSZ5224B	C4	2.66	2.8	2.94	20.0	30	1400	0.25	75	1.0
MMSZ5225B	C5	2.85	3.0	3.15	20.0	29	1600	0.25	50	1.0
MMSZ5226B	D1	3.14	3.3	3.47	20.0	28	1600	0.25	25	1.0
MMSZ5227B	D2	3.42	3.6	3.78	20.0	24	1700	0.25	15	1.0
MMSZ5228B	D3	3.71	3.9	4.10	20.0	23	1900	0.25	10	1.0
MMSZ5229B	D4	4.09	4.3	4.52	20.0	22	2000	0.25	5.0	1.0
MMSZ5230B	D5	4.47	4.7	4.94	20.0	19	1900	0.25	5.0	2.0
MMSZ5231B	E1	4.85	5.1	5.36	20.0	17	1600	0.25	5.0	2.0
MMSZ5232B	E2	5.32	5.6	5.88	20.0	11	1600	0.25	5.0	3.0
MMSZ5233B	E3	5.70	6.0	6.30	20.0	7	1600	0.25	5.0	3.5
MMSZ5234B	E4	5.89	6.2	6.51	20.0	7	1000	0.25	5.0	4.0
MMSZ5235B	E5	6.46	6.8	7.14	20.0	5	750	0.25	3.0	5.0
MMSZ5236B	F1	7.13	7.5	7.88	20.0	6	500	0.25	3.0	6.0
MMSZ5237B	F2	7.79	8.2	8.61	20.0	8	500	0.25	3.0	6.5
MMSZ5238B	F3	8.27	8.7	9.14	20.0	8	600	0.25	3.0	6.5
MMSZ5239B	F4	8.65	9.1	9.56	20.0	10	600	0.25	3.0	7.0
MMSZ5240B	F5	9.50	10	10.50	20.0	17	600	0.25	3.0	8.0
MMSZ5241B	H1	10.45	11	11.55	20.0	22	600	0.25	2.0	8.4
MMSZ5242B	H2	11.40	12	12.60	20.0	30	600	0.25	1.0	9.1
MMSZ5243B	H3	12.35	13	13.65	9.5	13	600	0.25	0.5	9.9
MMSZ5244B	H4	13.30	14	14.70	9.0	15	600	0.25	0.1	10
MMSZ5245B	H5	14.25	15	15.75	8.5	16	600	0.25	0.1	11
MMSZ5246B	J1	15.20	16	16.80	7.8	17	600	0.25	0.1	12
MMSZ5247B	J2	16.15	17	17.85	7.4	19	600	0.25	0.1	13
MMSZ5248B	J3	17.10	18	18.90	7.0	21	600	0.25	0.1	14
MMSZ5250B	J5	19.00	20	21.00	6.2	25	600	0.25	0.1	15
MMSZ5251B	K1	20.90	22	23.10	5.6	29	600	0.25	0.1	17
MMSZ5252B	K2	22.80	24	25.20	5.2	33	600	0.25	0.1	18
MMSZ5253B	K3	23.75	25	26.25	5.0	35	600	0.25	0.1	19
MMSZ5254B	K4	25.65	27	28.35	4.6	41	600	0.25	0.1	21
MMSZ5255B	K5	26.60	28	29.40	4.5	44	600	0.25	0.1	21
MMSZ5256B	M1	28.50	30	31.50	4.2	49	600	0.25	0.1	23
MMSZ5257B	M2	31.35	33	34.65	3.8	58	700	0.25	0.1	25
MMSZ5258B	M3	34.20	36	37.80	3.4	70	700	0.25	0.1	27
MMSZ5259B	M4	37.05	39	40.95	3.2	80	800	0.25	0.1	30
MMSZ5260B	M5	40.85	43	45.15	3.0	93	900	0.25	0.1	33
MMSZ5261B	N1	44.65	47	49.35	2.7	105	1000	0.25	0.1	36
MMSZ5262B	N2	48.45	51	53.55	2.5	125	1100	0.25	0.1	39
MMSZ5263B	N3	53.20	56	58.80	2.2	150	1300	0.25	0.1	43
MMSZ5264B	N4	57.00	60	63.00	2.1	170	1400	0.25	0.1	46
MMSZ5265B	N5	58.90	62	65.10	2.0	185	1400	0.25	0.1	47
MMSZ5266B	P1	64.60	68	71.40	1.8	230	1600	0.25	0.1	52
MMSZ5267B	P2	71.25	75	78.75	1.7	270	1700	0.25	0.1	56

Note : 5% tolerance of Zener voltage



Rating and characteristic curves (MMSZ5221B THRU MMSZ5267B)

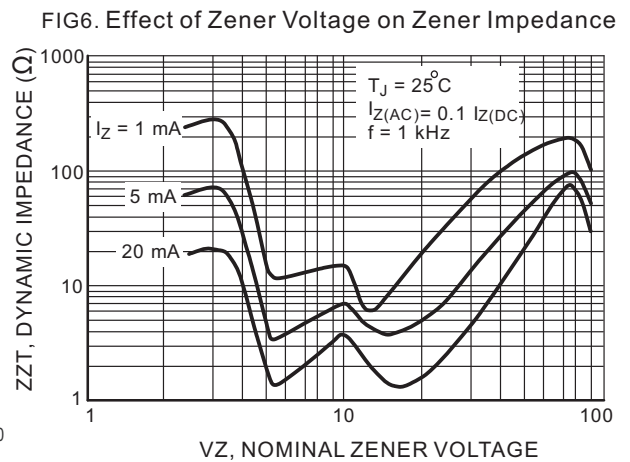
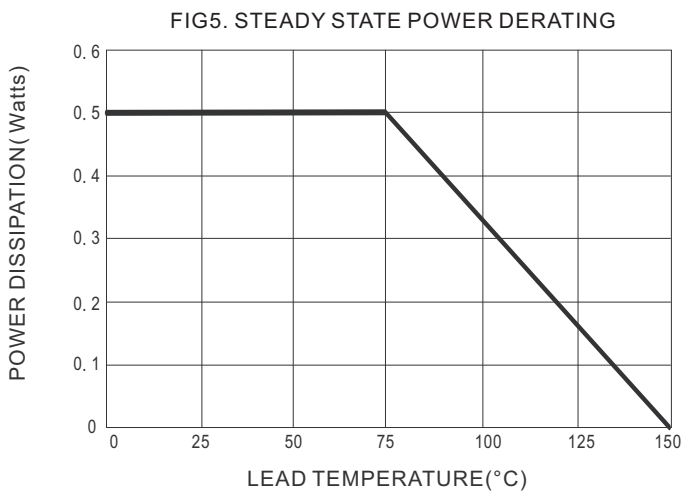
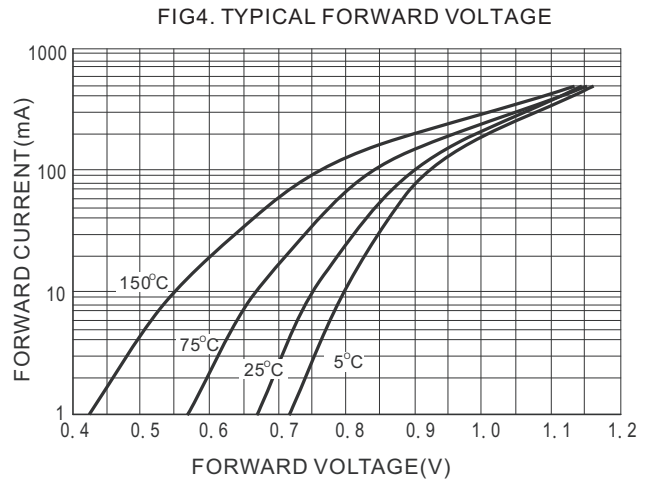
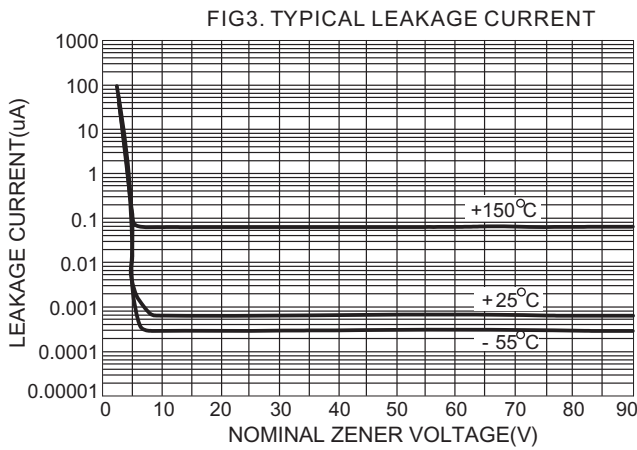
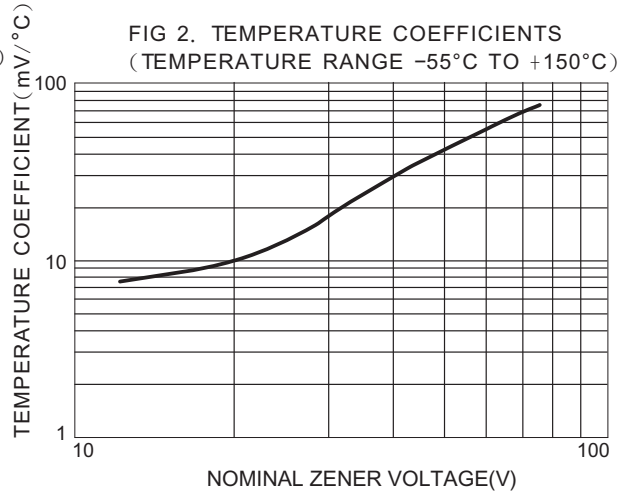
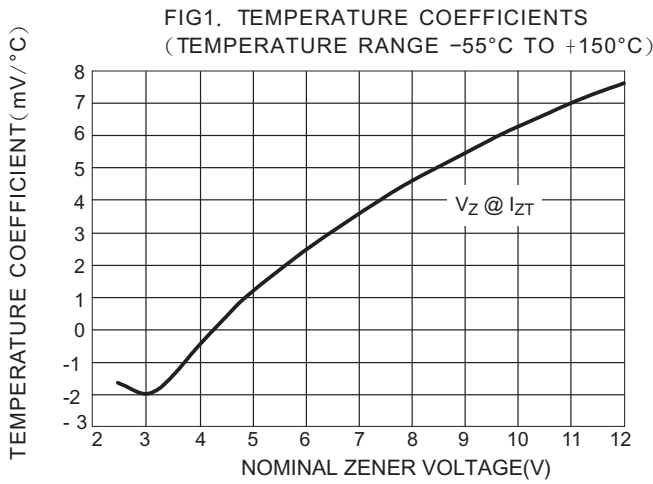

Rating and characteristic curves (MMSZ5221B THRU MMSZ5267B)

FIG7. Typical Capacitance

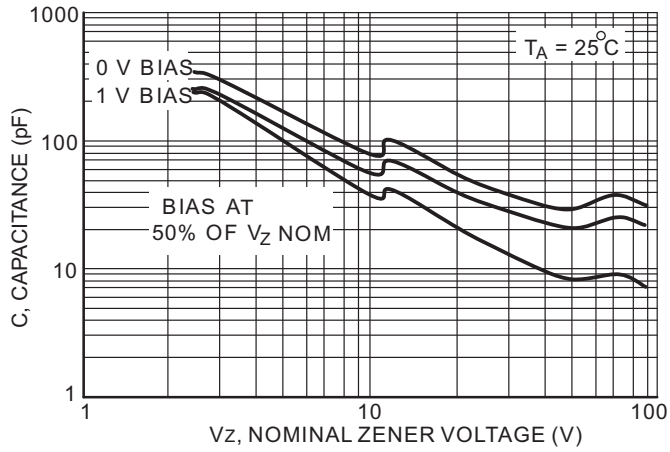

FIG8. Zener Voltage versus Zener Current (V_Z Up to 12 V)

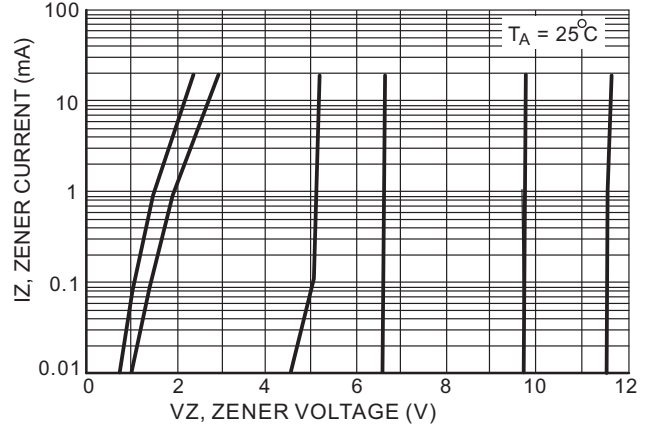
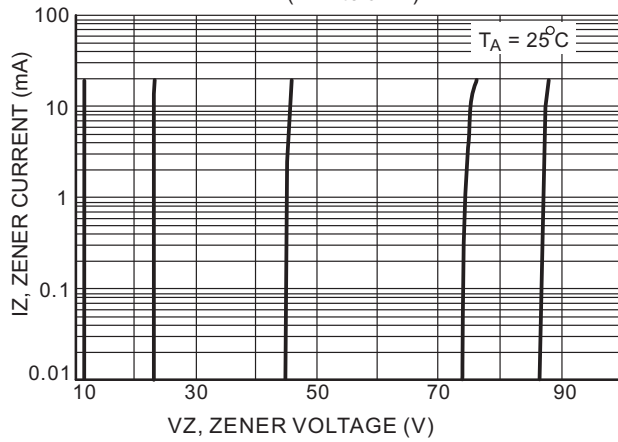



FIG9. Zener Voltage versus Zener Current (12V to 91 V)



MMSZ5221B THRU MMSZ5267B

Pinning information

Pin	Simplified outline	Symbol
Pin1 cathode Pin2 anode		

Suggested solder pad layout

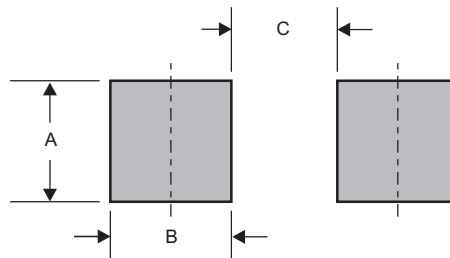

Dimensions in inches and (millimeters)

PACKAGE	A	B	C
SOD-123F	0.048 (1.22)	0.036 (0.91)	0.093 (2.36)

MMSZ5221B THRU MMSZ5267B

Packing information

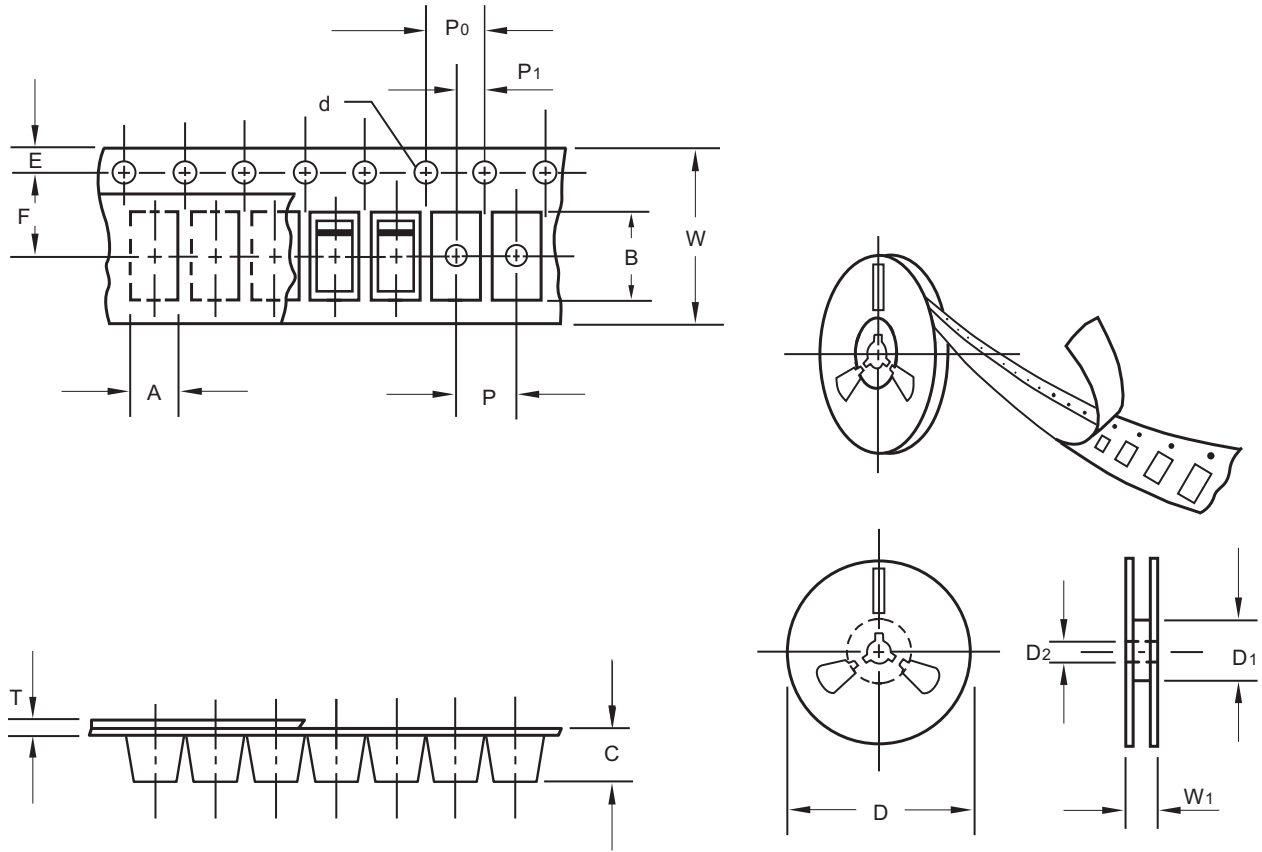

unit:mm

Item	Symbol	Tolerance	SOD-123F
Carrier width	A	0.1	2.00
Carrier length	B	0.1	3.85
Carrier depth	C	0.1	1.10
Sprocket hole	d	0.1	1.50
13" Reel outside diameter	D	2.0	-
13" Reel inner diameter	D1	min	-
7" Reel outside diameter	D	2.0	178.00
7" Reel inner diameter	D1	min	62.00
Feed hole diameter	D2	0.5	13.00
Sprocket hole position	E	0.1	1.75
Punch hole position	F	0.1	3.50
Punch hole pitch	P	0.1	4.00
Sprocket hole pitch	P0	0.1	4.00
Embossment center	P1	0.1	2.00
Overall tape thickness	T	0.1	0.23
Tape width	W	0.3	8.00
Reel width	W1	1.0	11.40

Note: Devices are packed in accordance with EIA standard RS-481-A and specifications listed above.

MMSZ5221B THRU MMSZ5267B

Reel packing

PACKAGE	REEL SIZE	REEL (pcs)	COMPONENT SPACING (m/m)	BOX (pcs)	INNER BOX (m/m)	REEL DIA, (m/m)	CARTON SIZE (m/m)	CARTON (pcs)	APPROX. GROSS WEIGHT (kg)
SOD-123F	7"	3,000	4.0	30,000	183*183*123	178	382*262*387	240,000	9.5

Suggested thermal profiles for soldering processes

- 1.Storage environment: Temperature=5°C~40°C Humidity=55%±25%
- 2.Reflow soldering of surface-mount devices

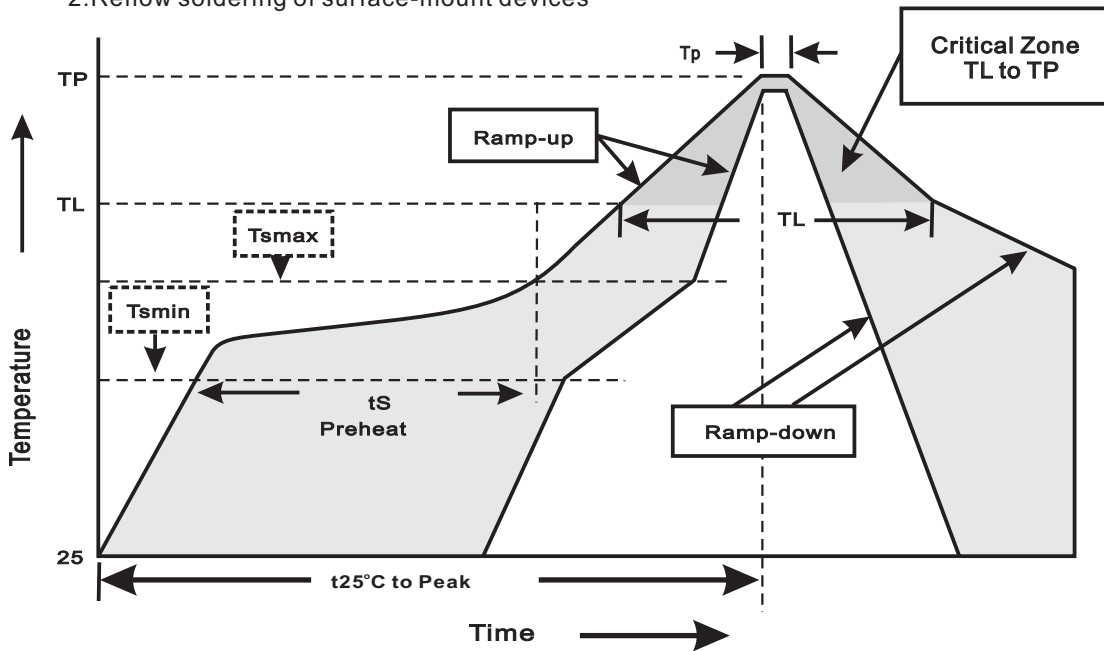

3.Reflow soldering

Profile Feature	Soldering Condition
Average ramp-up rate(TL to TP)	<3°C/sec
Preheat -Temperature Min(Tsmin) -Temperature Max(Tsmax) -Time(min to max)(ts)	150°C 200°C 60~120sec
Tsmax to TL -Ramp-upRate	<3°C/sec
Time maintained above: -Temperature(TL) -Time(tL)	217°C 60~260sec
Peak Temperature(TP)	255°C-0/+5°C
Time within 5°C of actual Peak Temperature(tp)	10~30sec
Ramp-down Rate	<6°C/sec
Time 25°C to Peak Temperature	<6minutes

MMSZ5221B THRU MMSZ5267B**High reliability test capabilities**

Item Test	Conditions	Reference
1. Solder Resistance	at $260\pm 5^{\circ}\text{C}$ for $10\pm 2\text{sec.}$ immerse body into solder $1/16''\pm 1/32''$	MIL-STD-750D METHOD-2031
2. Solderability	at $245\pm 5^{\circ}\text{C}$ for 5 sec.	MIL-STD-202F METHOD-208
3. High Temperature Reverse Bias	$V_R=80\%$ rate at $T_J=150^{\circ}\text{C}$ for 168 hrs.	MIL-STD-750D METHOD-1038
4. Pressure Cooker	$15P_{SIE}$ at $T_A=121^{\circ}\text{C}$ for 4 hrs.	JESD22-A102
5. Temperature Cycling	-55°C to $+125^{\circ}\text{C}$ dwelled for 30 min. and transferred for 5min. total 10 cycles.	MIL-STD-750D METHOD-1051
6. Humidity	at $T_A=85^{\circ}\text{C}$, RH=85% for 1000hrs.	MIL-STD-750D METHOD-1021
7. High Temperature Storage Life	at 175°C for 1000 hrs.	MIL-STD-750D METHOD-1031