

MN2310 Series

Precision, Low-Noise JFET Instrumentation Amplifiers

The MN2310 Series exceptionally low noise characteristics and low input bias current is made possible with the use of a large-area discrete JFET differential input stage. These selected and matched JFETs exhibit superior noise characteristics to those available in monolithic JFET instrumentation amplifiers.

The JFET input stage is combined with low-noise opamps to provide an exceptional bandwidth composite amplifier with low distortion characteristics. Precision laser-trimmed resistors facilitate high gain accuracy without the use of external resistors. Internal compensation provides maximum flat gain to 1MHz. One user-selected external capacitor is required to precisely set the 6dB/octave low-frequency gain roll-off, a feature often desired in AC amplifiers.

The devices are available in factory-set fixed gains of 30dB, 40dB, and 50dB (MN2310, MN2311, and MN2312, respectively) and are packaged in small 44-pin ceramic leadless chip carriers (CLCCs). Commercial devices are specified for 0°C to +70°C operation while "H" models are specified for -55°C to +125°C operation. "H/B" models are available with environmental stress screening while "H/B CH" models are compliant with MIL-H-38534 requirements.

Applications for the MN2310 Series include SONAR systems and other piezoelectric transducer-based systems (hydrophones, seismometers, accelerometers, condenser microphones) as well as CT scanners, Ultrasound, high energy physics instrumentation and other instrumentation.

Features:

- **Ultra Low Noise:**
1.65nV/ $\sqrt{\text{Hz}}$ Voltage Noise
4fA/ $\sqrt{\text{Hz}}$ Current Noise
- **Sub-Audio 1/f Noise Corner**
- **Fixed Gain:**
30dB (MN2310)
40dB (MN2311)
50dB (MN2312)
- **Gain Accuracy $\pm 0.25\text{dB}$**
- **Wide Power Supply Range $\pm 8\text{V}$ to $\pm 15\text{V}$**
- **1MHz Input Bandwidth**
- **True Differential Inputs**
600M Ω Impedance
- **Over Voltage Protected**
- **Small 44-pin CLCC (JEDEC "C")**
- **0°C to +70°C, -55°C to +125°C Operation**
- **Optional Environmental Stress Screening or Compliant MIL-H-38534 Models Available (Contact Factory)**

For additional information regarding Custom Microelectronic Products and Services, please contact Micro Networks at:



micro networks corporation

324 Clark St., Worcester, MA 01606
Tel. (508) 852-5400 • FAX (508) 853-8296
E-Mail – sales@mnc.com
Web Site – <http://www.mnc.com>

MN2310 Series

Low Noise JFET Instrumentation Amplifiers

Specifications

Specifications @ $T_A = +25^\circ\text{C}$, Supply Voltages $\pm 12\text{V}$, unless otherwise indicated

Parameter	Condition	Min.	Typ.	Max.	Units
Fixed Gain:					
MN2310	Single Ended Output		30		dB
MN2311			40		dB
MN2312			50		dB
MN2310	Balanced Output		36		dB
MN2311			46		dB
MN2312			56		dB
Gain Error @ $+25^\circ\text{C}$	$V_o = \text{Pin 24 to GND}$		± 0.1	± 0.25	dB
Gain Tempco	$V_o = \text{Pin 24 to GND}$			± 0.001	dB/ $^\circ\text{C}$
Input Characteristics					
Bias Current			4		pA
Impedance, Differential			600/12		$\text{M}\Omega/\text{pF}$
Impedance, Common Mode			150/48		$\text{M}\Omega/\text{pF}$
Overload Protection	100 μsec Current Pulse			0.5	A
Voltage Noise	@ 10kHz		1.65	2	$\text{nV}/\sqrt{\text{Hz}}$
Current Noise	@ 10kHz		4	20	$\text{fA}/\sqrt{\text{Hz}}$
Output Characteristics					
Voltage Swing:					
Single Ended	$R_L = 2\text{k}\Omega$, THD = -60dB		2.25		V rms
Balanced	$R_L = 2\text{k}\Omega$, THD = -60dB		4.50		V rms
Short Circuit Current	Pin 23, Pin 24		34		mA
Capacitive Load Stability	Pin 23, Pin 24		200		pF
Total Harmonic Distortion	$R_L = 2\text{k}\Omega$, $V_o = 2\text{V rms}$		-90		dB
Offset @ Pin 24	Unity D.C. Gain	25	50		mV
Small Signal Bandwidth	$V_o = -12\text{dB}$		1		MHz
Slew Rate			3.5		V/ μsec
Power Supply Requirements					
Power Supply Range		± 8	± 12	± 15	Volts
Current Drains:					
$+V_{CC}$			+12	+14	mA
$-V_{CC}$			-12	-14	mA

Specifications subject to change without notification as Micro Networks reserves the right to make improvements and changes in its products.



micro networks corporation

324 Clark St., Worcester, MA 01606
 Tel. (508) 852-5400 • FAX (508) 853-8296
 E-Mail – sales@mnc.com
 Web Site – <http://www.mnc.com>

MN2310 Series

Low Noise JFET Instrumentation Amplifiers

Absolute Maximum Ratings

Operating Temperature Range	-55°C to +125°C
Specified Temperature Range	
MN231X	0°C to +70°C
MN231XH, H/B, H/B CH	-55°C to +125°C
Storage Temperature Range	-65°C to +150°C
Supply Voltage	+/-15V
Analog Input Voltage	1V rms

Ordering Information

Part Number MN2310 H/B CH

Select desired gain. MN2310 for 30dB, MN2311 for 40dB and MN2312 for 50dB.

Select temperature range. Standard device is specified for 0°C to +70°C operation. Add "H" for -55°C to +125°C operation.

Add "/B" suffix for environmental stress screening to "H" models.

Add "CH" suffix to "H/B" models for compliant MIL-H-38534 processing. Consult factory for availability.

Block Diagram

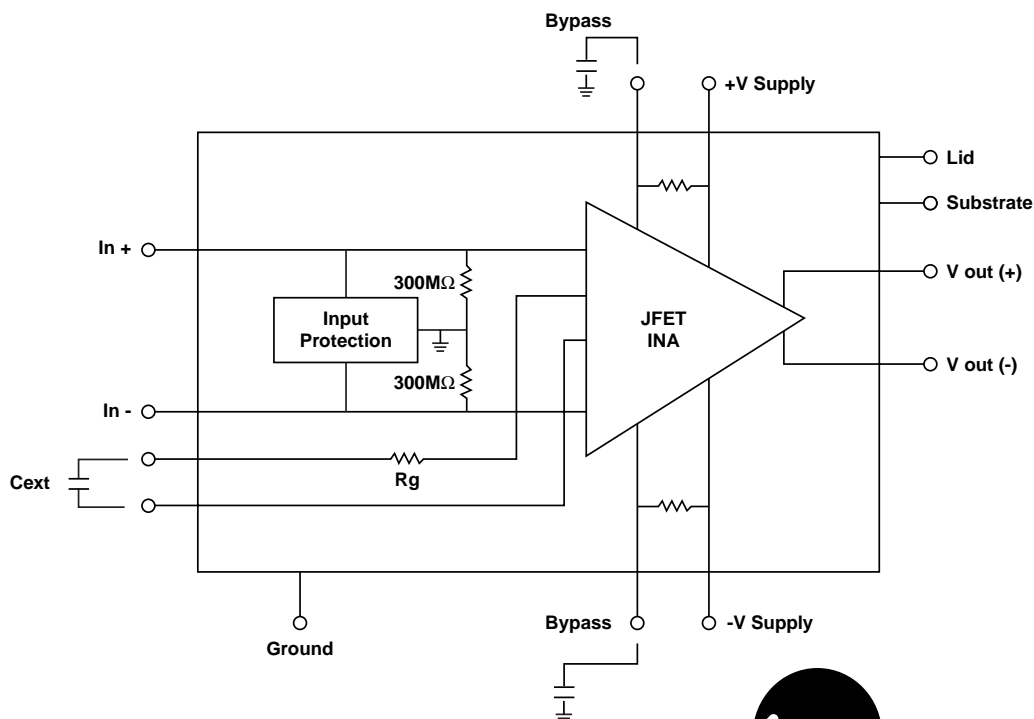

micro networks corporation

324 Clark St., Worcester, MA 01606
Tel. (508) 852-5400 • FAX (508) 853-8296
E-Mail – sales@mnc.com
Web Site – <http://www.mnc.com>

MN2310 Series

Low Noise JFET Instrumentation Amplifiers

Pin Designations

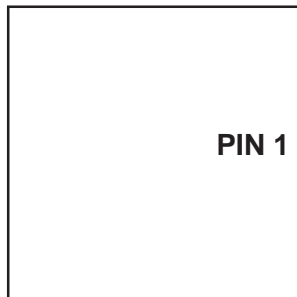

1. Cext/RAgain	12. NC	23. Voltage Out (+)	34. NC
2. Cext	13. NC	24. Voltage Out (-)	35. NC
3. Ground	14. -V Bypass	25. +V Supply	36. R9 Gain
4. NC	15. NC	26. NC	37. NC
5. NC	16. NC	27. +V Bypass	38. NC
6. NC	17. NC	28. NC	39. NC
7. NC	18. -V Bypass	29. NC	40. Input (+)
8. NC	19. NC	30. NC	41. Input (-)
9. NC	20. -V Supply	31. NC	42. NC
10. NC	21. NC	32. NC	43. Shield (Lid)
11. NC	22. NC	33. NC	44. Shield (Sub.)

Input Protection - Protecting the input stage of a low noise amplifier from destructive input transients is a complex problem. Normal diodes and MOV's present loading problems when placed across the input terminals. Biased diodes (diodes connected from the input leads to V+ and V- in a reversed condition) contribute to input noise current. Input series resistors used in a series current limiting circuit seriously add to the noise voltage (E_n) of most low noise amplifiers.

The MN2310 Series Low Noise Amplifiers contain a unique input protection circuit which has been carefully designed to protect the amplifier without causing unwanted noise performance deterioration. Standard product devices are protected from

current pulses of up to 2A-seconds from kilovolt transients (open circuit).

1/f noise for low audio and subaudio applications

- Highly sensitive instruments, such as seismographs and radiation detectors use the low audio and sub-audio frequency bands. In these applications, amplifiers are required to have exceptionally low 1/f noise characteristics. Unfortunately, all semiconductors exhibit some degree of 1/f noise depending on the type of semiconductor device and process. 1/f noise is typically quantified by identifying the break frequency $f/1$ where the noise density has risen 3dB above the mid band value.



micro networks corporation

324 Clark St., Worcester, MA 01606
Tel. (508) 852-5400 • FAX (508) 853-8296
E-Mail – sales@mnc.com
Web Site – <http://www.mnc.com>

MN2310 Series

Low Noise JFET Instrumentation Amplifiers

The n-type JFET front end in the MN2310 Series Low Noise Instrumentation Amplifiers produces exceptionally low 1/f noise. A typical noise density of the E_n parameter of the MN2310 is shown below.

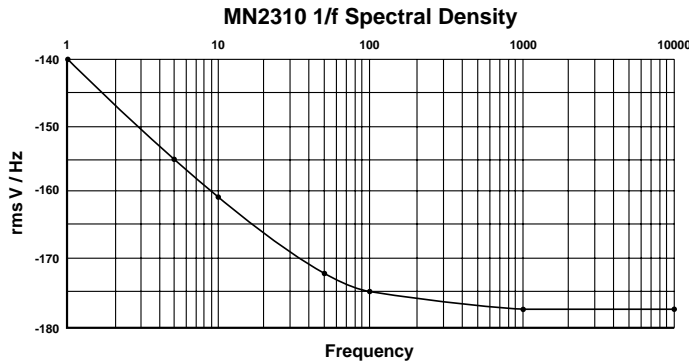

High CMR Amplifier - The MN2310 Series is shown below connected as a high-CMR ac amplifier. The ac configuration uses a single bypass capacitor (C_{ext}) to set the low frequency 3dB roll-off point. The low frequency roll-off as a function of the value of C_{ext} is given below and depicted in the following figure.

$$F_{3dB} = 1/2\pi RC \text{ where } R = 46\Omega$$

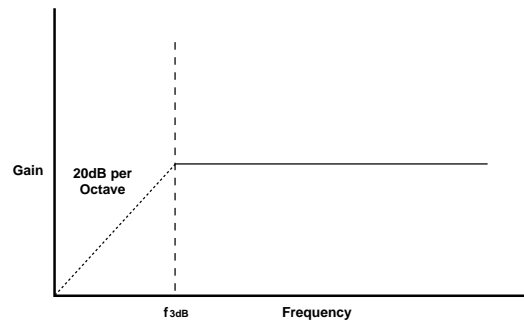
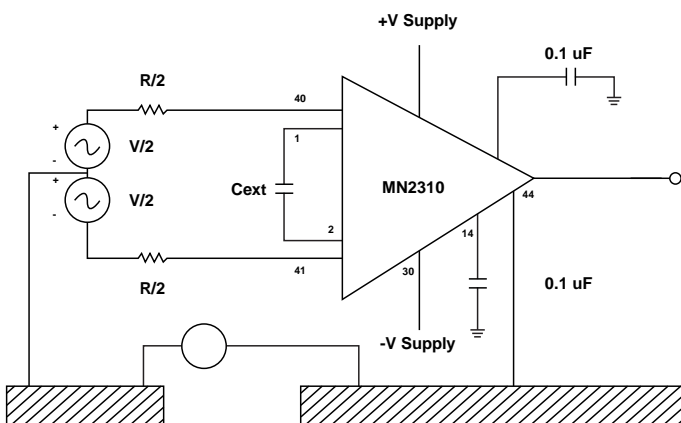

Adjusting Device Gain - The gain of the MN2310 Series Amplifiers is predetermined by three resistors, two of which are laser trimmed thin film resistor networks. However, access to the gain setting resistors (R_7 and R_9) for the MN2310 Series is provided for user-defined gains via external resistors. Resistors R_7 and R_9 are internal to the MN2310 Series amplifiers and have values as follows:

Device	Fixed Gain	$R_7(k\Omega)$	$R_9(\Omega)$
MN2310	30dB	1.42	46
MN2311	40dB	4.59	46
MN2312	50dB	14.50	46

Gain Formula:

$$\text{Gain (dB)} = 20 \text{ Log } (R_7 / R_{eq} + 0.5)$$

where $R_{eq} = R_9 // R_{ext}$ for an increase in gain or

where $R_{eq} = R_9 + R_{ext}$ to decrease gain.



micro networks corporation

324 Clark St., Worcester, MA 01606
Tel. (508) 852-5400 • FAX (508) 853-8296
E-Mail – sales@mnc.com
Web Site – <http://www.mnc.com>

MN2310 Series

Low Noise JFET
Instrumentation Amplifiers

Performance Curves

Frequency Response

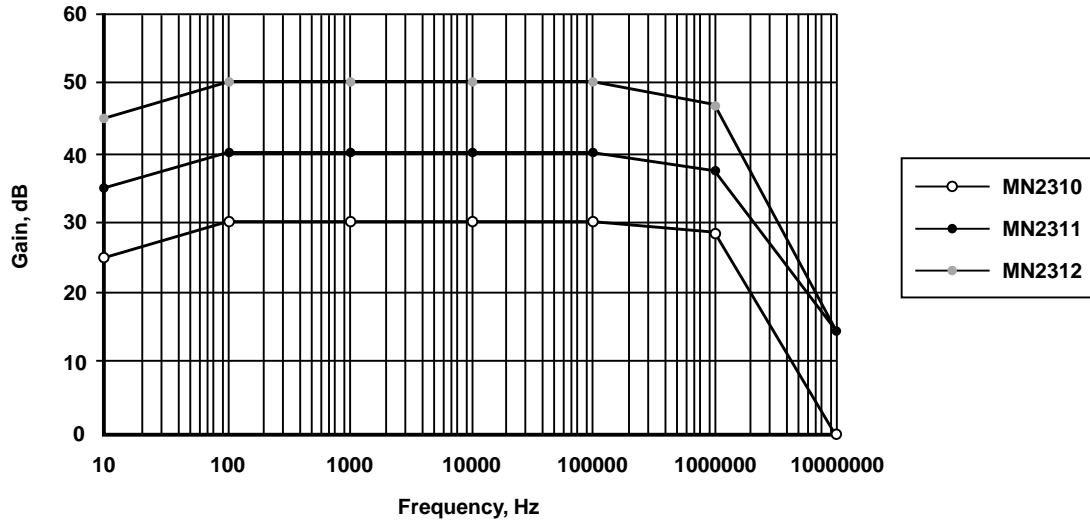

Total Harmonic Distortion, MN2311

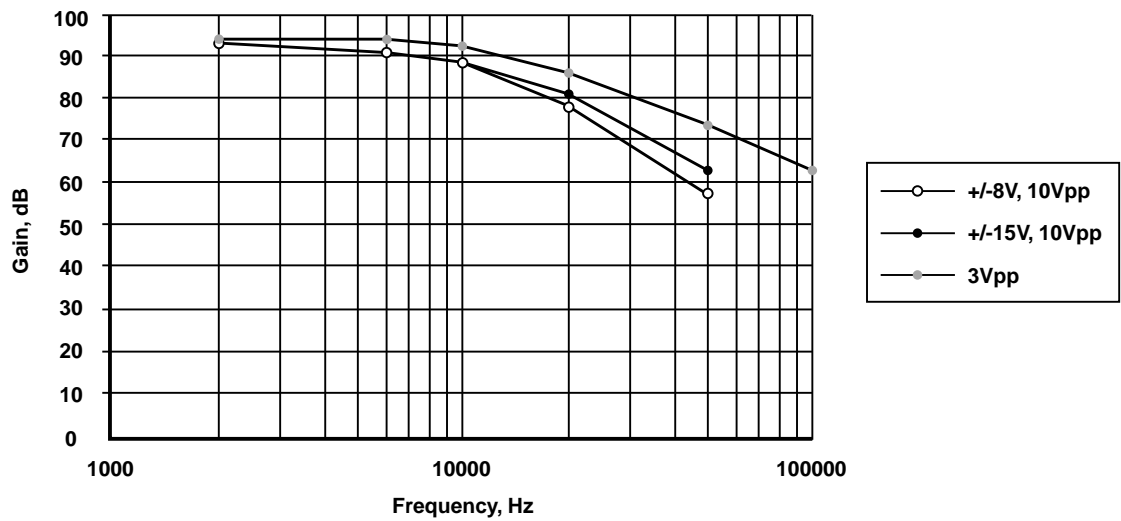

micro networks corporation

324 Clark St., Worcester, MA 01606
Tel. (508) 852-5400 • FAX (508) 853-8296
E-Mail – sales@mnc.com
Web Site – <http://www.mnc.com>

MN2310 Series

Low Noise JFET
Instrumentation Amplifiers

Performance Curves

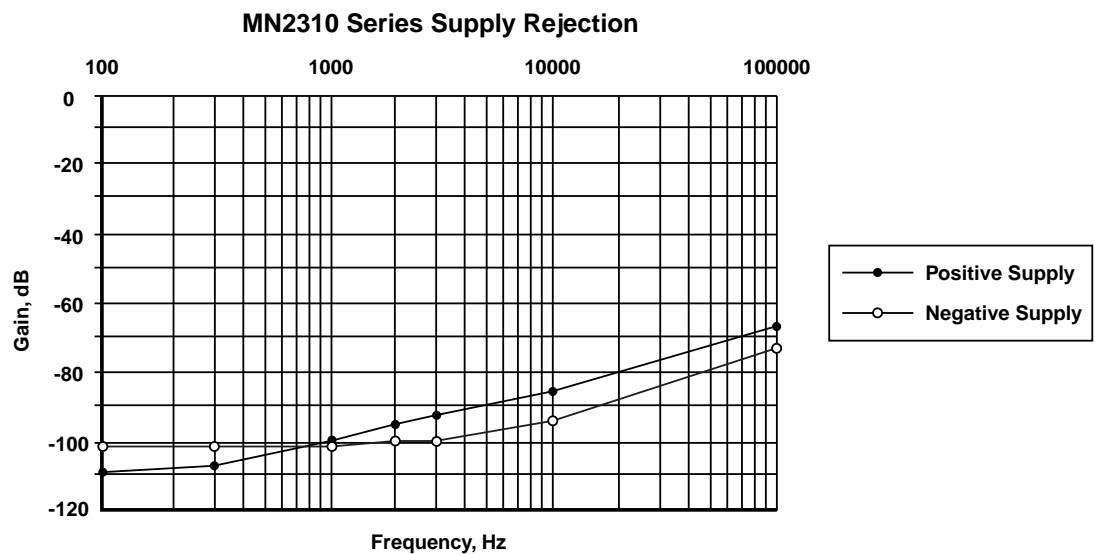
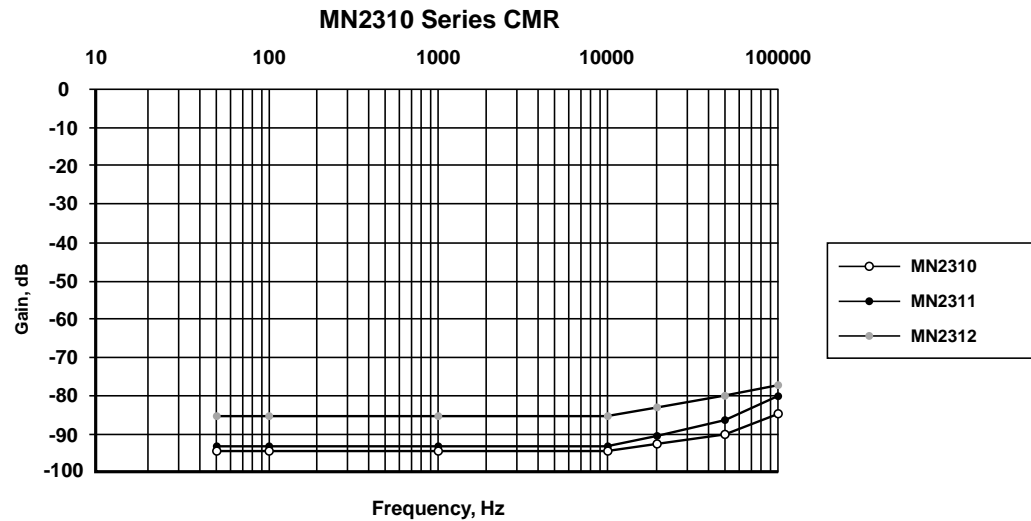

micro networks corporation

324 Clark St., Worcester, MA 01606
Tel. (508) 852-5400 • FAX (508) 853-8296
E-Mail – sales@mnc.com
Web Site – <http://www.mnc.com>

MN2310 Series

Low Noise JFET Instrumentation Amplifiers

Performance Curves

Noise as a Function of Frequency

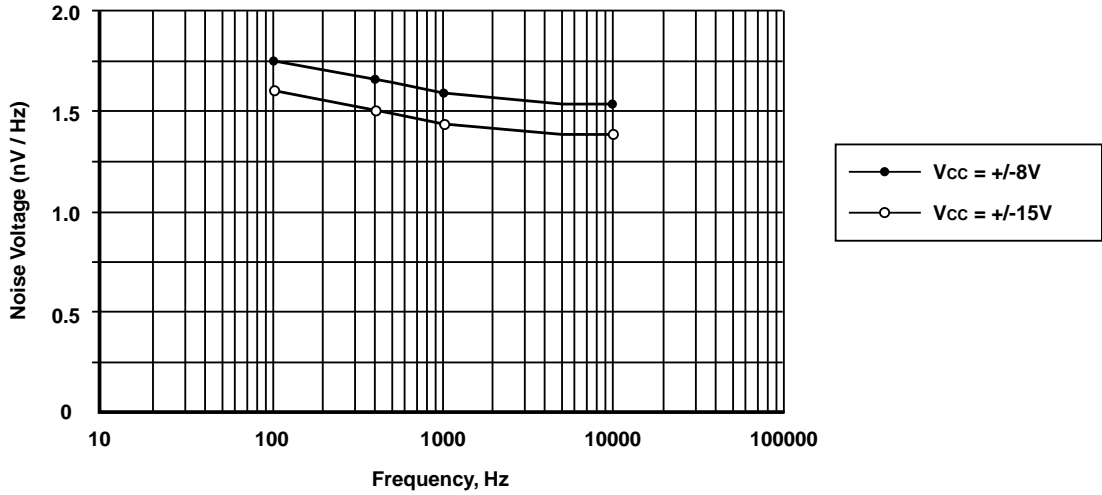

Package Outline

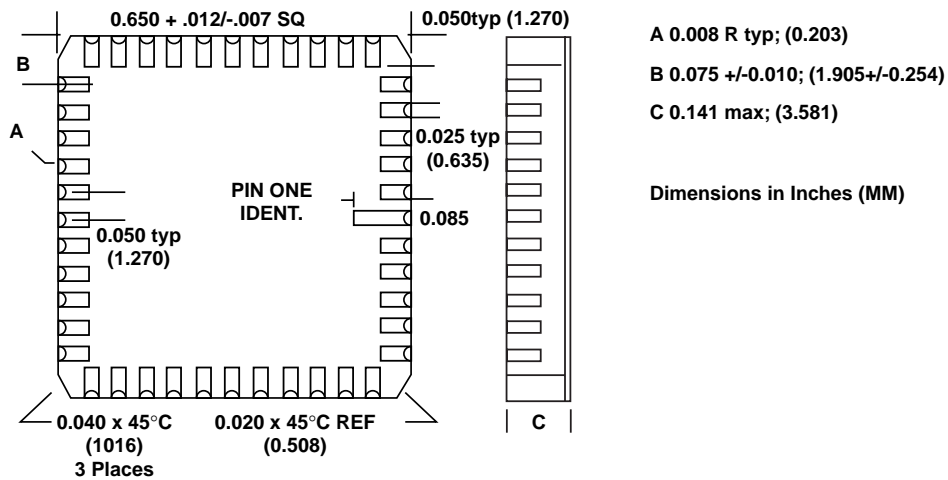

micro networks corporation

324 Clark St., Worcester, MA 01606
 Tel. (508) 852-5400 • FAX (508) 853-8296
 E-Mail – sales@mnc.com
 Web Site – <http://www.mnc.com>