

# DATA SHEET

Part No.	MN2DS0003
Package Code No.	LQFP256-P-2828

SEMICONDUCTOR COMPANY  
MATSUSHITA ELECTRIC INDUSTRIAL CO., LTD.

# MN2DS0003

## Single-chip LSI for DVD players

### ■ Overview

This is a super single-chip LSI for DVD players. A DVD player can be built by connecting this LSI, a driver IC, SDRAM, a flash memory, audio output DAC, and so on.

This LSI builds in Analog Front End (analogFE) for analog signal processing, an optical disk controller which deals with servo control, and error correction, AV decoder which supports MPEG1/MPEG2/JPEG video decoding and DVD Audio/Windows Media Audio (WMA)/MP3 audio decoding, and a 32-bit CPU as a system controller with instruction cache.

### ■ Feature

- High readability with built-in analog front-end DRC (digital read channel)
- Various audio decoding (DVD Audio/WMA/MP3)
- Progressive output
- 4.7 G RAM play
- FE/BE Unified Memory Architecture
- Built-in Audio PLL

### ■ Applications

DVD player for DVD-Audio and DVD-RAM

### ■ System block diagram of DVD player

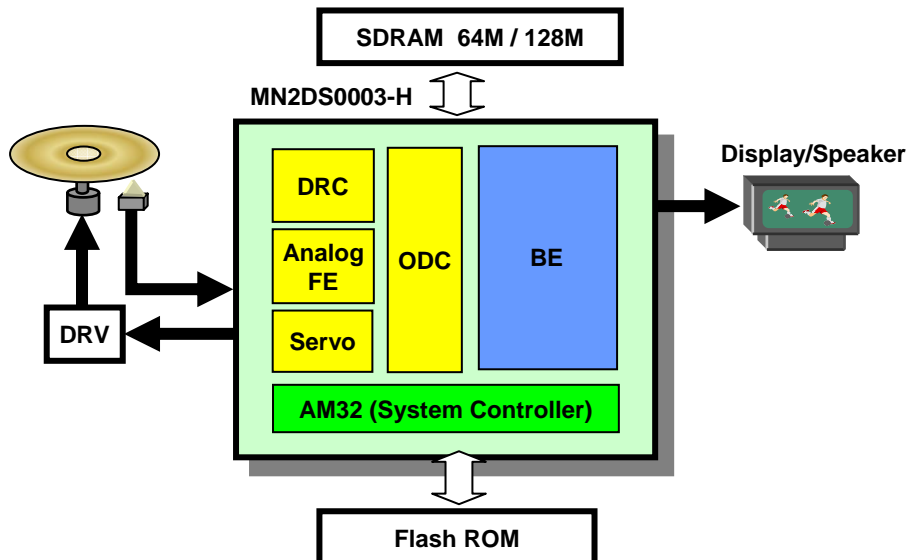

Microsoft, Windows Media and the Windows logo are trademarks, or registered trademarks of Microsoft corporation in the United States and/or other countries.

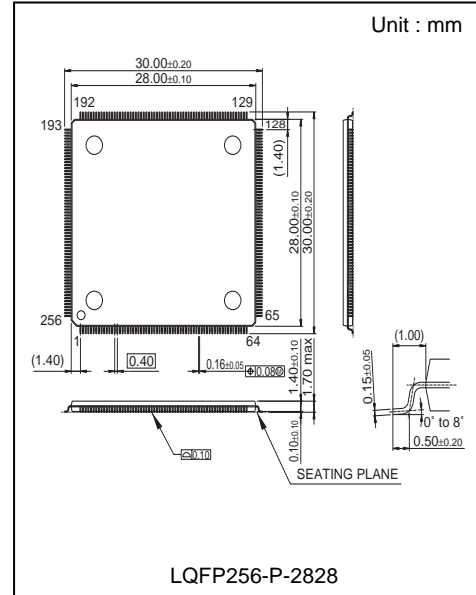

Note : The detailed information for this product is disclosed after non-disclosure agreement between your company and MEI.

## ■ Specifications

BLOCK	FUNCTION	FEATURE
SYSTEM CONTROLLER	CPU Core	Load/store architecture of five-step pipelining Linear address space is supported by no more than 4G bytes. 4K bytes instruction cache memory and 8K bytes data RAM
	Flash-ROM BUS I/F	Memory capacity up to 1-64 M bits. Address/data multiplex mode and separation mode are supported.
	Timer	16-bit up/down counter × 2 (Up/Down counter) 8-bit down counter × 8 (Down counter/Cascade connection available) Watchdog timer
	Serial I/F	Synchronous type (including I2C)/UART × 4 7/8-bit character length selectable, sends bit order selectable from LSB/MSB
FE	Error Correction	DVD error correction (Inner: 5 pile correction, Outer: 8 pile correction, 16 burst correction) All CD-ROM mode including video CD data processing are supported. CLV 16th velocity continuous reading, CD-DA look-ahead function, CD-Text
	Analog signal processing	Circuit which operates the signal from an optical pick-up and the RF signal processing circuit are built in.
	SERVO control function	Focus servo control, tracking servo control and traverse servo control function Automatic adjustments (balance adjustment and gain adjustment for focus/tracking) CLV control and CAV control by FG signal
	CIRC function	Synchronous reproduction of rotation around disk (jitter free) mode function CD error correction (C1: double correction, C2: four pile correction) Built-in audio circuit and differential OP amplifier (2-degree LPF)
	FE/BE memory sharing	FE/BE Unified Memory Architecture
BE	Stream decoding	MPEG1 system stream/MPEG2 program stream
	Video decoding	MPEG1 video standard/MPEG2 video standard
	Still picture decoding	DVD sub-image (SPU)·SVCD sub-image (OGT) DVD-Audio still picture JPEG (Exif standard conforming)
	Audio decoding	Dolby Digital™·dts™ MPEG1&2 Layer2/Layer3 (MP3) DVD Video standard Linear PCM/DVD Audio standard (Linear PCM/MLP) WMA™·CD-DA
	Copyright protection	Descramble function (CSS, CPPM, CPRM) Audio Watermark detection·CGMS·WSS Macrovision Rev.7.1.L1· Macrovision (Progressive) Rev.1.2
	Video output	54 MHz 10-bit DAC (5-ch.) NTSC/PAL/PAL60 encode Progressive output (525P/625P) Y/Cb/Cr output (interlace/progressive) Y/C/Composite output (interlace) RGB output·Digital video output (REC656)
	Audio output	PCM output: 6-ch. + Mix 2-ch. Digital audio output (IEC60958/61937)
	Other functions	OSD two-plain display Scaling function of main image, sub-image, and JPEG image
Power	3.3 V(I/O)/1.2V (Core)	
Package	LQFP-256-pin	

Dolby Digital is a registered trademark of the Dolby Laboratories Licensing Corp.  
dts is a registered trademark of the DTS Technology.

Windows Media is a trademark or registered trademark of Microsoft Corporation in the United States and/or other countries.

## Request for your special attention and precautions in using the technical information and semiconductors described in this material

- (1) An export permit needs to be obtained from the competent authorities of the Japanese Government if any of the products or technical information described in this material and controlled under the "Foreign Exchange and Foreign Trade Law" is to be exported or taken out of Japan.
- (2) The technical information described in this material is limited to showing representative characteristics and applied circuits examples of the products. It neither warrants non-infringement of intellectual property right or any other rights owned by our company or a third party, nor grants any license.
- (3) We are not liable for the infringement of rights owned by a third party arising out of the use of the technical information as described in this material.
- (4) The products described in this material are intended to be used for standard applications or general electronic equipment (such as office equipment, communications equipment, measuring instruments and household appliances).  
Consult our sales staff in advance for information on the following applications:
  - Special applications (such as for airplanes, aerospace, automobiles, traffic control equipment, combustion equipment, life support systems and safety devices) in which exceptional quality and reliability are required, or if the failure or malfunction of the products may directly jeopardize life or harm the human body.
  - Any applications other than the standard applications intended.
- (5) The products and product specifications described in this material are subject to change without notice for modification and/or improvement. At the final stage of your design, purchasing, or use of the products, therefore, ask for the most up-to-date Product Standards in advance to make sure that the latest specifications satisfy your requirements.
- (6) When designing your equipment, comply with the guaranteed values, in particular those of maximum rating, the range of operating power supply voltage, and heat radiation characteristics. Otherwise, we will not be liable for any defect which may arise later in your equipment.  
Even when the products are used within the guaranteed values, take into the consideration of incidence of break down and failure mode, possible to occur to semiconductor products. Measures on the systems such as redundant design, arresting the spread of fire or preventing glitch are recommended in order to prevent physical injury, fire, social damages, for example, by using the products.
- (7) When using products for which damp-proof packing is required, observe the conditions (including shelf life and amount of time let standing of unsealed items) agreed upon when specification sheets are individually exchanged.
- (8) This material may be not reprinted or reproduced whether wholly or partially, without the prior written permission of Matsushita Electric Industrial Co., Ltd.