

MN2WS0025 Single-Chip HDTV System LSI



MN2WS0025 FEATURES

- **Plug-and-Play/OpenCable™** and DVB ready with a on-chip **CableCARD™** interface and Common Interface.
- Reference design available including **OpenCable™** software stacks.
- Video input for ITU-R BT.656 format.
- Video scaling and aspect conversion.
- Unified Memory Architecture. Main memory is DDR333 or DDR400 SDRAM with capacity from 128 Mbits to 2 Gbits.
- NAND flash memory interface (8- and 16-bit) that supports ECC calculation and error detection.
- Compact BGA package, 23 mm², with maximum power consumption of only 2 W.
- 32-bit RISC CPU delivers 200 MIPS and makes efficient use of system resources by using variable-length instructions.
- Transport decoder can demultiplex one stream from up to 3 sources; 48 PID filters, 40 section filters, supports partial TS output.
- Conditional access support: DES-ECB for **Plug-and-Play/OpenCable™**, Multi2 descrambler for Japanese satellite, and DVB common descrambler for Europe.
- Available 2-channel audio digital input with synchronization to video signal output.
- Video and audio decoding for MPEG1, MPEG2 (MP@HL, MP@ML, SP@ML, MP@LL), AAC, and Dolby® Digital (AC-3).

MN2WS0025 BENEFITS

- Built-in **CableCARD™** interface reduces system cost.
- Complete hardware and software design package dramatically reduces time-to-market.
- Optional software modules support a variety of DTV functions including the **CableCARD™** stack for **Plug-and-Play/OpenCable™**, DTV closed captioning, and channel map database.
- Development support and access to Panasonic Semiconductor's "customer room." Available source feeds for ATSC, NTSC, and both Motorola and SA headends. Also available are **HPNX™** verification tools required to test **Plug-and-Play/OpenCable™** compliance and Sarnoff bitstreams to test MPEG and PSIP compliance.
- Reference design comes complete with:
 - Schematics and Gerber files
 - Bill of materials (BOM)
 - Datasheets
 - Software stacks
 - Applications support

MN2WS0025 OVERVIEW

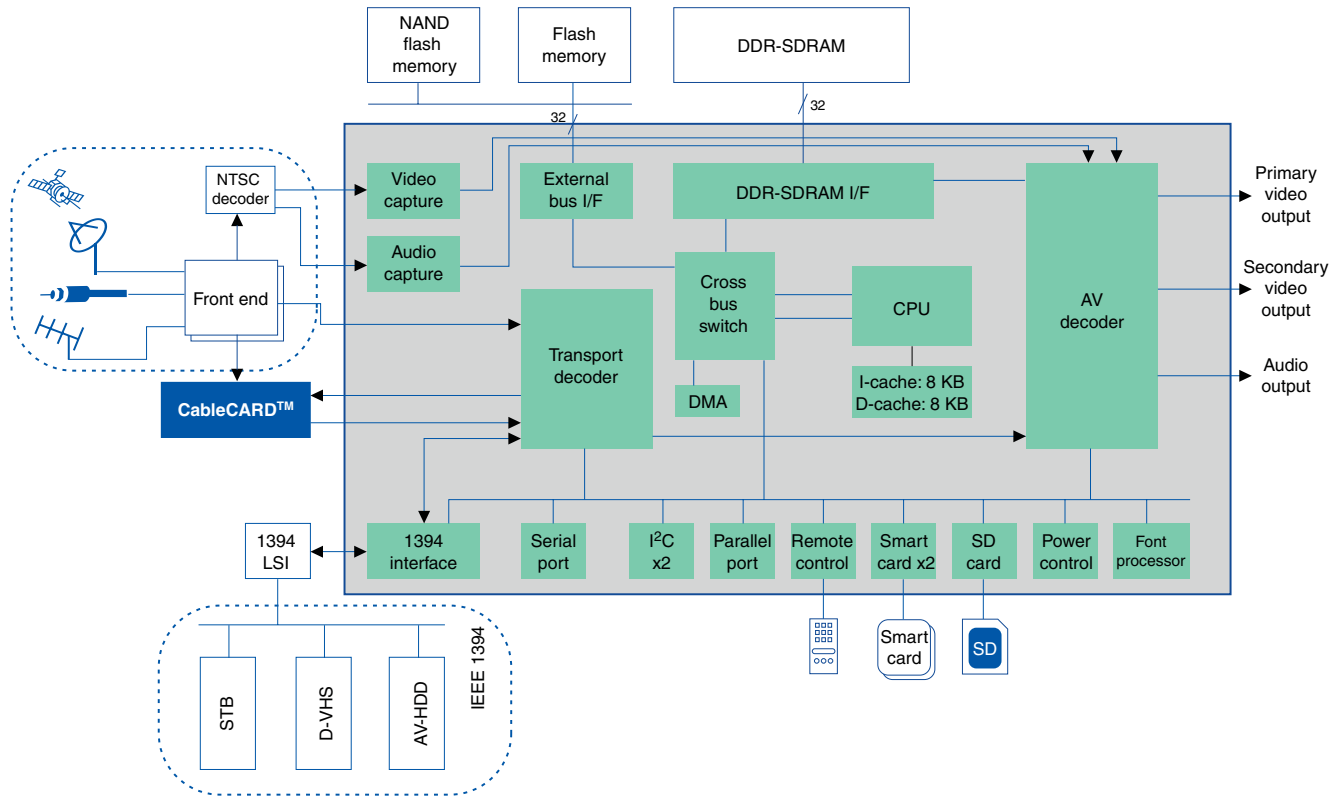

MN2WS0025 System Block Diagram

The **MN2WS0025** is a single-chip HDTV system LSI intended for use in DTV and STB applications in the United States, Japan, and Europe. This chip can be used to design a very low-cost yet highly featured product. With the built-in **CableCARD™** interface, the **MN2WS0025** directly supports U.S. **Plug-and-Play/OpenCable™**.

This chip provides the back-end processing necessary for receiving digital HDTV broadcasts: transport stream decoding (TS), MPEG video and audio decoding, peripheral functions, and system processing. A standard system requires just two 128-Mbit DDR-SDRAM chips.

The chip supports the U.S. terrestrial standard (ATSC), the **Plug-and-Play/OpenCable™** standard, the Japanese terrestrial standard (ISDB-T), both Japanese satellite standards (ISBD-S and DVB-S), and other digital broadcast specifications from around the world. The **MN2WS0025** also includes the **CableCARD™** interface for the U.S. **OpenCable™** specifications and the interface for European DVB specifications.

To enhance system efficiency, the **MN2WS0025** has the following internal peripheral I/O interfaces:

- Three synchronous/asynchronous serial interfaces
- Parallel (GPIO) interface
- SD card interface
- Two smart card interfaces
- High-speed I/O port for MPEG-TS
- IR remote control interface
- Two I²C interfaces
- NAND/NOR flash memory interface

An audio delay function is also built-in for synchronizing audio and video when receiving analog broadcasts as part of an integrated analog and digital system.

MN2WS0025 REFERENCE SYSTEM

Panasonic Semiconductor's system board for the **MN2WS0025** provides a complete **Plug-and-Play** hardware reference design to "jump-start" software development using the Panasonic Semiconductor software development kit. We provide source code for transport demux, MPEG AV decoding, Digital Dolby audio decoding, ITU-R BT.656 video capture, channel navigation user interface sample, nonvolatile memory access, and simple command-line shell for debugging. Optional modules for **Plug-and-Play/OpenCable™** and DTV closed captioning are also available.

The **MN2WS0025** resides on the main (or back-end) board and is the heart of the system. This board controls all other functions in the system and performs transport, video and audio decoding, video scaling, graphics compositing, ITU-R BT.656 video capture, and video and audio output. The reference system also includes a front-end board that provides the tuning and demodulation for **Plug-and-Play/OpenCable™**, terrestrial ATSC and NTSC, and inputs for S-video, composite video, and L/R audio.

A front panel board receives and decodes IR commands and scans the front panel buttons. This board has the capability to emulate a TV microcontroller by acting as an I²C master while the main board is an I²C slave, simplifying the use of **MN2WS0025** as a plug-in DTV module for an existing NTSC television.

Reference design comes complete with:

- Schematics and Gerber files
- Bill of materials (BOM)
- Datasheet and user manual
- Software source code for device drivers
- Applications support

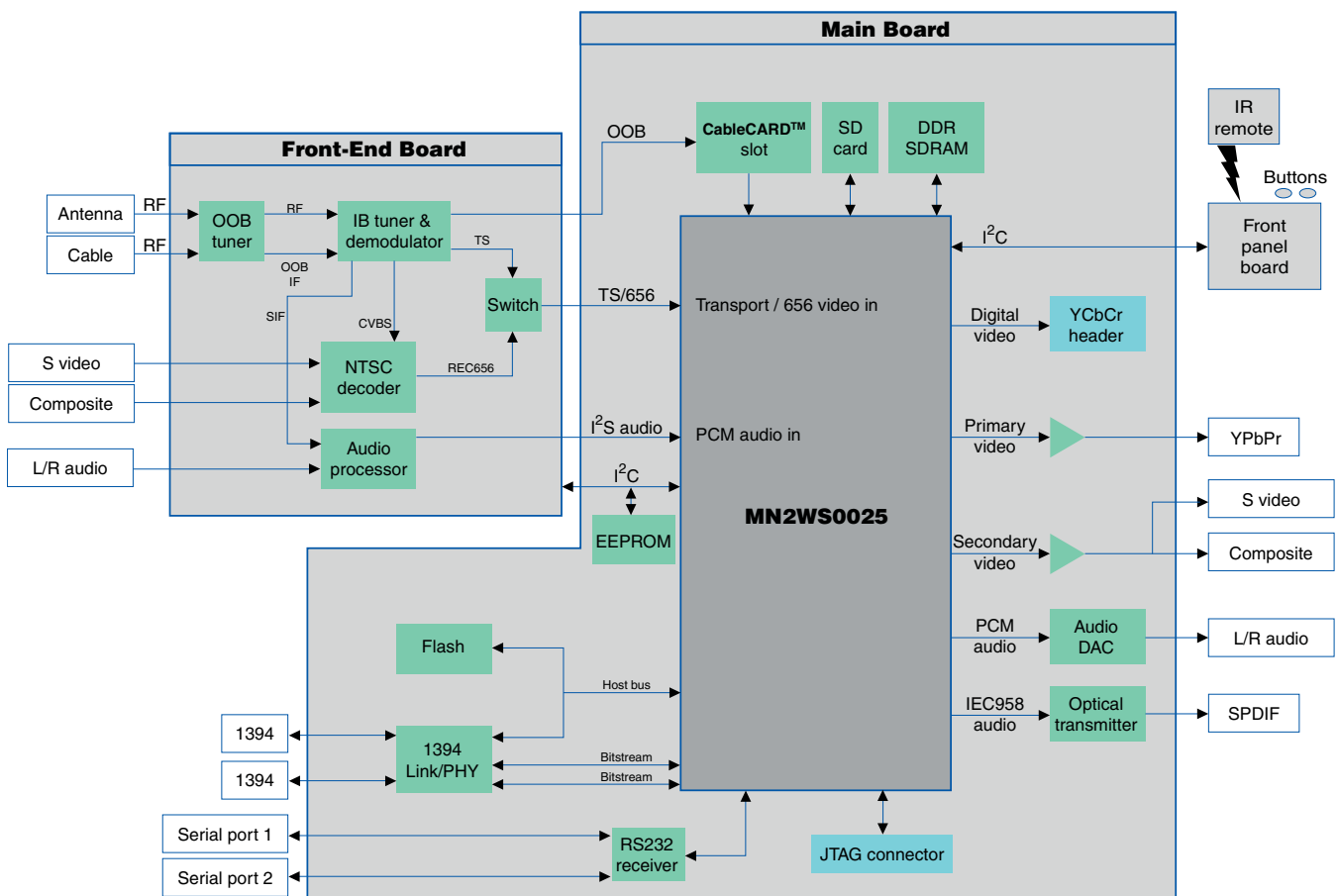

MN2WS0025 Reference System Block Diagram

Reference System Features

- **Plug-and-Play/OpenCable™** ready—built-in interface for **CableCARD™**
- Receives all ATSC and digital cable video and audio formats
- Integrated AV capture of NTSC
- Supports closed captioning extraction from NTSC and digital video
- Supports reinsertion of closed captioning into built-in NTSC encoder
- Tuning and demodulation for QAM64/256, QPSK, 8VSB, and NTSC
- Inputs
 - Two RF inputs for cable and terrestrial
 - S-video and composite video
 - L/R audio
- Outputs
 - Primary video output as analog component YPbPr, 480I/P, and 1080I; digital output also available
 - Secondary video output as S-video or composite video, 480I
 - L/R baseband audio
 - SPDIF optical digital audio
- User controls
 - IR remote control interface
 - Front panel keys
 - Demo software has on-screen display
- Development support
 - Two serial ports
 - JTAG connector for development system
 - I²C interfaces (configurable as master or slave)
- Options
 - IEEE 1394 plug-in module
 - Two optional SD card interfaces for firmware download or JPEG viewer

Panasonic Semiconductor Development Center
550 South Winchester Blvd., Suite 300
San Jose, CA 95128
Tel: 408-423-9511
Fax: 408-551-4499
Web site <http://www.psd.com>

- Memory
 - 32-MB flash
 - 32-MB DDR SDRAM
 - 64-KB EEPROM



MN2WS0025 Reference System

ABOUT PANASONIC SEMICONDUCTOR

Panasonic has a long history of developing world-class consumer products. In the United States, Panasonic was first to introduce an HDTV STB in 1998, and in 2003 Panasonic was first to introduce an integrated DTV with both ATSC and **OpenCable™** reception. There is no question that Panasonic is a world leader in digital television. Panasonic Semiconductor's DTV LSIs, proven in Panasonic consumer products, are also widely used by major DTV manufacturers around the world. We provide strong support to all manufacturers.

Panasonic consumer products are built from the ground up with only the best components and integrated circuits. Panasonic Semiconductor makes many of these components and integrated circuits to ensure the highest quality in our consumer products. Now you can use the same integrated circuits that made Panasonic a world leader in DTV.

Integrated circuits are just one piece of the DTV puzzle. To be successful in DTV, knowledge of the DTV marketplace and the required standards is key. Also critical are a thorough understanding of how the complete system works and how to implement hardware and software to present a compelling proposition to the customer. Panasonic Semiconductor's high-quality products and customer support are the answer to the DTV puzzle.

Copyright © 2004 Semiconductor Company, Matsushita Electric Industrial Co., Ltd. All rights reserved. CableCARD and OpenCable are trademarks of Cable Television Laboratories, Inc. HPNX is a trademark of Digital Keystone, Inc. Dolby Digital is a registered trademark of Dolby Laboratories, Inc. All product names that appear in this material are for identification purposes only and are acknowledged to be trademarks or registered trademarks of their respective companies. Information supplied by Panasonic Semiconductor is believed to be accurate and reliable, but Semiconductor Company, Matsushita Electric Industrial Co., Ltd., assumes no responsibility for any errors that may appear in this material. Panasonic Semiconductor reserves the right, without notice, to make changes in product design or specification.

Publication No. T02003AE
System LSI Product Brief for DTV
May 2004, 1st Edition
Issued by Semiconductor Company, Matsushita Electric Industrial Co., Ltd.
© Matsushita Electric Industrial Co., Ltd.

Printed in the U.S.A.