

**MPQ3725A**  
**NPN SILICON**  
**QUAD TRANSISTOR**

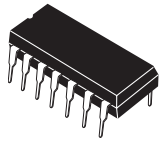

**TO-116 CASE**

# Central<sup>TM</sup>

**Semiconductor Corp.**

**DESCRIPTION:**

The CENTRAL SEMICONDUCTOR MPQ3725A type is comprised of four independent silicon NPN transistors mounted in a 14-Pin DIP case, designed for core driver applications.

**MARKING CODE: FULL PART NUMBER**

**MAXIMUM RATINGS:** ( $T_A=25^\circ\text{C}$ )

Collector-Emitter Voltage
Collector-Emitter Voltage
Emitter-Base Voltage
Collector Current
Power Dissipation (each transistor)
Power Dissipation (total package)
Operating and Storage Junction Temperature

SYMBOL		UNITS
$V_{CES}$	70	V
$V_{CEO}$	50	V
$V_{EBO}$	5.0	V
$I_C$	1.0	A
$P_D$	1.0	W
$P_D$	2.5	W
$T_J, T_{stg}$	-65 to +150	$^\circ\text{C}$

**ELECTRICAL CHARACTERISTICS:** ( $T_A=25^\circ\text{C}$ )

SYMBOL	TEST CONDITIONS	MIN	MAX	UNITS
$I_{CBO}$	$V_{CB}=40\text{V}$		500	nA
$BV_{CEO}$	$I_C=10\text{mA}$	50		V
$BV_{CES}$	$I_C=100\mu\text{A}$	70		V
$BV_{EBO}$	$I_E=10\mu\text{A}$	5.0		V
$V_{CE(SAT)}$	$I_C=500\text{mA}, I_B=50\text{mA}$		0.45	V
$V_{BE(SAT)}$	$I_C=500\text{mA}, I_B=50\text{mA}$	0.8	1.0	V
$h_{FE}$	$V_{CE}=1.0\text{V}, I_C=100\text{mA}$	40		
$h_{FE}$	$V_{CE}=2.0\text{V}, I_C=500\text{mA}$	30		
$f_T$	$V_{CE}=10\text{V}, I_C=50\text{mA}, f=100\text{MHz}$	200		MHz
$C_{ob}$	$V_{CB}=10\text{V}, I_E=0, f=1.0\text{MHz}$		10	pF
$C_{ib}$	$V_{EB}=0.5\text{V}, I_C=0, f=1.0\text{MHz}$		80	pF

TO-116 CASE - MECHANICAL OUTLINE

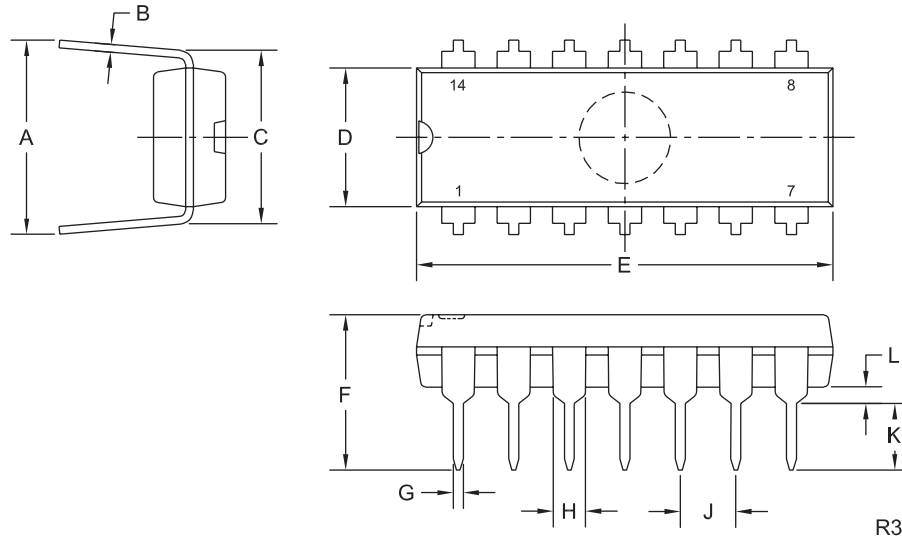

SYMBOL	INCHES		MILLIMETERS	
	MIN	MAX	MIN	MAX
A	0.310	0.390	7.9	9.9
B	0.008	0.014	0.2	0.4
C	0.310		7.9	
D	0.240	0.260	6.1	6.6
E	0.740	0.760	18.8	19.3
F	-	0.300	-	7.6
G	0.014	0.022	0.4	0.6
H	0.050		1.3	
J	0.100		2.5	
K	0.125	0.150	3.2	3.8
L	0.015	-	0.4	-

TO-116 (REV: R3)

MARKING CODE: FULL PART NUMBER

PIN CONFIGURATION

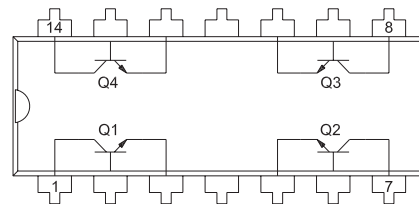

LEAD CODE:

- |                 |                  |
|-----------------|------------------|
| 1) COLLECTOR Q1 | 8) COLLECTOR Q3  |
| 2) BASE Q1      | 9) BASE Q3       |
| 3) EMITTER Q1   | 10) EMITTER Q3   |
| 4) NC           | 11) NC           |
| 5) EMITTER Q2   | 12) EMITTER Q4   |
| 6) BASE Q2      | 13) BASE Q4      |
| 7) COLLECTOR Q2 | 14) COLLECTOR Q4 |